

Oxford-Duden Pictorial English Dictionary with English-Arabic Index

Oxford-Duden Pictorial Dictionaries provide clear and simple illustrated coverage of over 28,000 complex objects from every aspect of life today.

This dictionary is an invaluable guide to hundreds of different topics, including business, technology, finance, the environment, sport and entertainment, and the world that surrounds us. It is designed for both English and Arabic speakers, and contains a full English-Arabic index.

أكثر من 28,000 مادة من 11 مجالا مختلفا، إلى جانب
مسرد إنجليزي - عربي كامل

بداية من الموضوعات العامة إلى تلك المتخصصة للغاية، توفر
سلسلة "قاموس أو كسفورد - دودن المصوّرة" تغطية مبسطة
وواضحة لآلاف المواد المعقدة التي نتعرض لها في كافة جوانب
حياتنا اليومية.

هذا القاموس يعتبر مرشدا قيّما إلى مئات من الموضوعات المختلفة،
من ضمنها: الأعمال التجارية والتكنولوجيا والمالية والبيئة
والرياضة والتسوية والعالم المحيط بنا. وهو يناسب كلا من متحدثي
الإنجليزية والعربية على حد سواء.

The World's Most Trusted Dictionaries

Oxford University Press is the world's leading dictionary-maker, publishing highly acclaimed bilingual dictionaries at every level, in over 40 different languages.

OXFORD

UNIVERSITY PRESS

www.oup.com

AskOxford.COM

Oxford Dictionaries Passionate about language

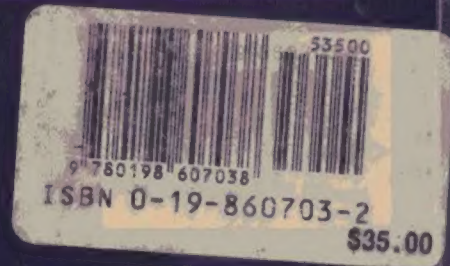

Oxford
Duden
Pictorial

English Dictionary with English-Arabic Index
قاموس أو كسفورد - دودن الإنجليزي المصور مع مسرد إنجليزي - عربي



OXFORD

Oxford-Duden PICTORIAL ENGLISH Dictionary with English-Arabic Index



THE WORLD'S MOST TRUSTED DICTIONARIES

Oxford-Duden
Pictorial English Dictionary
with English-Arabic Index

English-Arabic Index prepared by
Moustafa Gabr

OXFORD
UNIVERSITY PRESS

Great Clarendon Street, Oxford OX2 6DP

Oxford University Press is a department of the University of Oxford.
It furthers the University's objective of excellence in research, scholarship,
and education by publishing worldwide in

Oxford New York

Auckland Bangkok Buenos Aires Cape Town Chennai
Dar es Salaam Delhi Hong Kong Istanbul Karachi Kolkata
Kuala Lumpur Madrid Melbourne Mexico City Mumbai
Nairobi São Paulo Shanghai Taipei Tokyo Toronto

Oxford is a registered trademark of Oxford University Press
in the UK and in certain other countries

Published in the United States
by Oxford University Press Inc., New York

© Illustrations: Bibliographisches Institut, Mannheim 1979, 1995, 2003
© English text: Oxford University Press 1979, 1995, 2003
© English-Arabic Index: Moustafa Gabr 2003

All rights reserved. No part of this publication may be reproduced,
stored in a retrieval system, or transmitted, in any form or by any means,
without the prior permission in writing of Oxford University Press,
or as expressly permitted by law, or under terms agreed with the appropriate
reprographic rights organization. Enquiries concerning reproduction
outside the scope of the above should be sent to the Rights Department,
Oxford University Press, at the address above

The word 'DUDEN' is a registered trademark of the
Bibliographisches Institut for books of any kind

British Library Cataloguing in Publication Data
Data available

Library of Congress Cataloging in Publication Data
Data available

ISBN 0 19 860201 4 (hardback)
ISBN 0 19 860703 2 (paperback)

Pictorial English Dictionary edited by Michael Clark and Bernadette Mohan.
Illustrations by Jochen Schmidt, Mannheim.
Co-ordinating editors of the second edition: Michael Clark, Oxford and
Werner Scholze-Stubenrecht, Mannheim.
English-Arabic Index prepared by Moustafa Gabr

10 9 8 7 6 5 4 3 2

Printed in Hong Kong

CONTENTS

Full Contents	6-9
Oxford-Duden Pictorial English Dictionary	10-671
English-Arabic Index	673-965

Guide to using the dictionary

The Pictorial English Dictionary, English-Arabic index, and Contents are ordered thematically under the following topic headings:

- The Atom, the Universe, and the Earth
- Man and his Social environment
- Nature as Environment, Agriculture, and Forestry
- Trades, Crafts, and Industry
- Printing Industry
- Transport, Communications, and Information Technology
- Office, Bank, and Stock Exchange
- Community
- Recreation, Games, and Sport
- Entertainment, Culture, and Art
- Animals and Plants

To find the Arabic translation for a vocabulary item, first browse the subject areas listed in the Contents (pp. 6-9); select your relevant subject area, and locate its corresponding number in the Dictionary (numbers are at the top corner of each page). When you have found your vocabulary item, go to the relevant entry in the Index.

Abbreviations

Am.	<i>American usage</i>
c.	<i>castrated (animal)</i>
coll.	<i>colloquial</i>
f.	<i>female (animal)</i>
form.	<i>formerly</i>
joc.	<i>jocular</i>
m.	<i>male (animal)</i>
poet.	<i>poetic</i>
sg.	<i>singular</i>
sim.	<i>similar</i>
y.	<i>young (animal)</i>

OXFORD-DUDEN
PICTORIAL ENGLISH
DICTIONARY

قاموس أوكسفورد - دودن
الإنجليزي المصور

Contents

The arabic numerals are the numbers of the pictures

Atom, Universe, Earth

Atom I 1
Atom II 2
Astronomy I 3
Astronomy II 4
Astronomy III 5
Moon Landing 6
Atmosphere 7
Meteorology I 8
Meteorology II and Climatology 9
Meteorological Instruments 10
Physical Geography I 11
Physical Geography II 12
Physical Geography III 13
Map I 14
Map II 15

Man and his Social Environment

Man I 16
Man II 17
Man III 18
Man IV 19
Man V 20
First Aid 21
Doctor I 22
Doctor II 23
Dentist 24
Hospital I 25
Hospital II 26
Hospital III 27
Infant Care and Layette 28
Children's Clothes 29
Ladies' Wear I (Winter Wear) 30
Ladies' Wear II (Summer Wear) 31
Underwear, Nightwear 32
Men's Wear 33
Hairstyles and Beards 34
Headgear 35
Jewellery (*Am.* Jewelry) 36
Types of Dwelling 37
Roof and Boiler Room 38
Kitchen 39
Kitchen Utensils and Appliances 40
Hall 41
Living Room 42
Bedroom 43
Dining Room 44
Tableware and Cutlery 45
Flat (Apartment) 46

Children's Room (Nursery) 47
Kindergarten (Day Nursery) 48
Bathroom and Toilet 49
Household Appliances and Utensils 50

Nature as Environment, Agriculture, and Forestry

Flower Garden 51
Fruit and Vegetable Garden 52
Indoor Plants (Houseplants) 53
Propagation of Plants 54
Market Garden (*Am.* Truck Garden, Truck Farm) 55
Garden Tools 56
Vegetables (Vegetable Plants) 57
Soft Fruit and Pomes 58
Drupes and Nuts 59
Garden Flowers 60
Weeds 61
Farm Buildings (*Am.* Farmstead) 62
Agriculture (Farming) 63
Agricultural Machinery I 64
Agricultural Machinery II 65
Agricultural Implements 66
Overhead Irrigation 67
Arable Crops 68
Fodder Plants (Forage Plants) 69
Breeds of Dog 70
Horse I 71
Horse II 72
Domestic Animals 73
Poultry Farming (Poultry Keeping), Egg Production 74
Rearing (*Am.* Raising) of Livestock 75
Dairy 76
Bees and Beekeeping (Apiculture) 77
Wine growing (Vinciculture, Viticulture) 78
Wine Cellar 79
Garden and Field Pests 80
House Insects, Food Pests, and Parasites 81
Forest Pests 82
Pest Control 83
Forestry I 84
Forestry II 85
Hunting 86
Hunting Weapons, Hunting Equipment 87
Game 88
Fish Farming (Fish Culture, Pisciculture) and Angling 89
Sea Fishing 90

Trades, Crafts, and Industry

Mills 91
Malting and Brewing I 92
Brewing II 93
Slaughterhouse (Abattoir) 94
Meat Joints 95
Butcher's Shop 96
Bakery 97
Grocer's Shop (*Am.* Grocery Store) 98
Supermarket 99
Shoemaker (Bootmaker) 100
Shoes (Footwear) 101
Needlework 102
Dressmaker 103
Tailor 104
Ladies' Hairdresser 105
Men's Hairdresser (Barber) 106
Tobacco and Smoking Requisites 107
Goldsmith, Silversmith 108
Watchmaker, Clockmaker 109
Clocks and Watches 110
Optician 111
Optical Instruments I 112
Optical Instruments II 113
Photography I 114
Photography II 115
Photography III 116
Cine Film 117
Building Site (Construction Site) I 118
Building Site (Construction Site) II 119
Carpenter 120
Roof, Timber Joints 121
Roof and Roofer 122
Floor, Ceiling, Staircase Construction 123
Glazier 124
Plumber 125
Plumber, Gas Fitter, Heating Engineer 126
Electrician 127
Paperhanger 128
Painter 129
Cooper and Tank Construction Engineer 130
Furrier 131
Joiner I 132
Joiner II 133
Do-it-yourself 134
Turner 135
Basket Maker 136
Blacksmith (Smith) I 137
Blacksmith (Smith) II (Farm Vehicle Engineering) 138
Hammer Forging (Smith Forging) and Drop Forging 139
Metalworker 140
Gas Welder 141
Arc Welder 142
Sections, Bolts, and Machine Parts 143
Coal Mine 144

Mineral Oil (Oil, Petroleum) 145
Offshore Drilling 146
Iron and Steel Works 147
Iron Foundry and Rolling Mill 148
Machine Tools I 149
Machine Tools II 150
Drawing Office 151
Power Plant (Power Station) I 152
Power Plant (Power Station) II 153
Nuclear Energy 154
Modern Sources of Energy 155
Coking Plant 156
Sawmill 157
Quarry 158
Brickworks (Brickyard, Brickfield) 159
Cement Works (Cement Factory) 160
Porcelain and China Manufacture 161
Glass Production 162
Cotton Spinning I 163
Cotton Spinning II 164
Weaving I 165
Weaving II 166
Knitting 167
Finishing of Textile Fabrics 168
Synthetic (Man-made) Fibres (*Am.* Fibers) I 169
Synthetic (Man-made) Fibres (*Am.* Fibers) II 170
Weaves and Knits 171
Papermaking I 172
Papermaking II 173

Printing Industry

Typesetting Room (Composing Room) I 174
Typesetting Room (Composing Room) II 175
Typesetting Room III (Phototypesetting, Photocomposition, Photosetting) 176
Photomechanical Reproduction 177
Electrotyping and Block Making 178
Offset Platemaking 179
Offset Printing 180
Letterpress Printing 181
Photogravure (Gravure Printing, Intaglio Printing) 182
Bookbinding I 183
Bookbinding II 184
Bookbinding III 185

Transport, Communications, and Information Technology

Horse-drawn Carriages 186
Bicycle 187
Motorcycles, Bicycles, Scooters, Mopeds 188
Motorcycle 189
Internal Combustion Engines 190
Motor Car (*Am.* Automobile) I 191
Motor Car (*Am.* Automobile) II 192

Motor Car (*Am. Automobile*) III 193
Lorries (*Am. Trucks*), Vans, Buses 194
Garage (*Am. Shop*) 195
Service Station 196
Tram (*Am. Streetcar, Trolley*),
Interurban Electric Train 197
Cross-section of a Street 198
Refuse Disposal (*Am. Garbage Disposition*),
Street Cleaning 199
Road Construction I (Road Building,
Road Making) 200
Road Construction II (Road Building,
Road Making) 201
Railway Line (*Am. Railroad Track*) I 202
Railway Line (*Am. Railroad Track*) II
(Signalling Equipment) 203
Station Concourse 204
Station Platform 205
Goods Station (Freight Depot) 206
Railway Vehicles (Rolling Stock) I 207
Railway Vehicles (Rolling Stock) II 208
Railway Vehicles (Rolling Stock) III 209
Railway Vehicles (Rolling Stock) IV 210
Railway Vehicles (Rolling Stock) V 211
Railway Vehicles (Rolling Stock) VI 212
Railway Vehicles (Rolling Stock) VII 213
Mountain Railways (*Am. Railroads*)
and Cableways 214
Bridges 215
Rivers and River Engineering 216
Waterway and Hydraulic Engineering 217
Types of Historical Ship 218
Sailing Ship I 219
Sailing Ship II 220
Types of Ship 221
Shipbuilding 222
Motor Ship 223
Navigation 224
Docks, Port, Harbour (*Am. Harbor*) I 225
Docks, Port, Harbour (*Am. Harbor*) II 226
Salvage (*Salving*) and Towing 227
Life Saving 228
Aircraft I 229
Aircraft II 230
Aircraft III 231
Aircraft IV 232
Airport 233
Space Flight I 234
Space Flight II 235
Post Office I 236
Post Office II (Telecommunications) 237
Broadcasting (Radio and Television) I 238
Broadcasting (Radio and Television) II 239
Broadcasting III (Television Engineering) 240
Music Systems (Audio Systems) I 241
Music Systems (Audio Systems) II 242
Video Equipment 243

Personal Computer (PC) 244

Office, Bank, Stock Exchange

Office I 245
Office II 246
Office III 247
Office IV 248
Office V 249
Bank 250
Stock Exchange 251

Community

Money (Coins and Notes,
Am. Coins and Bills) 252
Flags 253
Heraldry, Crowns and Coronets 254
Armed Forces I (Army) 255
Armed Forces II (Air Force I) 256
Armed Forces III (Air Force II) 257
Warships I 258
Warships II (Modern Fighting Ships) 259
School I (Primary School) 260
School II (Secondary School, High School) 261
University 262
Election 263
Police 264
Café 265
Restaurant 266
Hotel 267
Town (Town Centre, *Am. Downtown*) 268
Water Supply 269
Fire Service (*Am. Fire Department*) 270
Department Store 271
Park 272

Recreation, Games, Sport

Children's Playground 273
Spa 274
Roulette 275
Board Games and Party Games 276
Billiards 277
Camping and Caravanning
(*Am. Trailing*) 278
Surf Riding (Surfing), Skin Diving 279
Bathing Beach 280
Swimming Bath (Leisure Centre,
Am. Center) 281
Swimming 282
Rowing and Canoeing 283
Sailing I 284
Sailing II 285
Motorboats (Powerboats), Water Skiing 286
Gliding (Soaring) 287
Aerial Sports (Airsports) 288
Horseanship, Equestrian Sport 289
Cycle Racing and Motorsports 290

Ball Games I (Football, Association Football,
Soccer) 291
Ball Games II 292
Ball Games III 293
Fencing 294
Free Exercise 295
Apparatus Gymnastics I 296
Apparatus Gymnastics II (Women's
Gymnastics) 297
Athletics (Track and Field Events) 298
Weightlifting and Combat Sports 299
Mountaineering 300
Winter Sports I (Skiing) 301
Winter Sports II 302
Winter Sports III 303
Countryside in Winter 304
Various Sports 305

Entertainment, Culture, and Art

Carnival 306
Circus 307
Fair, Fairground 308
Flea Market 309
Films (Motion Pictures) I 310
Films (Motion Pictures) II 311
Films (Motion Pictures) III 312
Films (Motion Pictures) IV 313
Ballet 314
Theatre (*Am. Theater*) I 315
Theatre (*Am. Theater*) II 316
Discotheque 317
Nightclub 318
Bullfighting, Rodeo 319
Musical Notation I 320
Musical Notation II 321
Musical Instruments I 322
Musical Instruments II 323
Musical Instruments III 324
Musical Instruments IV 325
Musical Instruments V 326
Fabulous Creatures (Fabled Beings) 327
Prehistory 328
Chivalry 329
Church I 330
Church II 331
Church III 332
Art I 333
Art II 334
Art III 335
Art IV 336
Art V 337
Artist's Studio 338
Sculptor's Studio 339

Graphic Art 340
Script I 341
Script II 342
Colour (*Am. Color*) 343
Mathematics I 344
Mathematics II 345
Mathematics III (Geometry I) 346
Mathematics IV (Geometry II) 347
Mathematics V (Sets) 348
Chemistry Laboratory I 349
Chemistry Laboratory II 350
Crystals, Crystallography 351
Ethnology I 352
Ethnology II 353
Ethnology III 354
Historical Costumes 355

Animals and Plants

Zoo (Zoological Gardens) 356
Invertebrates 357
Arthropods 358
Birds I 359
Birds II (Indigenous Birds, Endemic Birds) 360
Birds III (Passerines) 361
Birds IV (Birds of Prey) 362
Birds V (Exotic Birds) 363
Fish, Amphibia, and Reptiles 364
Lepidoptera (Butterflies and Moths) 365
Mammals I 366
Mammals II 367
Mammals III 368
Deep-sea Fauna 369
General Botany 370
Deciduous Trees 371
Conifers 372
Ornamental Shrubs and Trees I 373
Ornamental Shrubs and Trees II 374
Meadow Flowers and Wayside Flowers
(Wild Flowers) I 375
Meadow Flowers and Wayside Flowers
(Wild Flowers) II 376
Plants of Forest, Marsh, and Heathland 377
Alpine Plants, Aquatic Plants (Water Plants),
and Marsh Plants 378
Poisonous Plants 379
Medicinal Plants 380
Edible Fungi (Esculent Fungi) 381
Tropical Plants used as Stimulants, Spices,
and Flavourings (*Am. Flavorings*) 382
Plants used in Industry 383
Southern Fruits (Tropical, Subtropical,
and Mediterranean Fruits) 384

1-8 atom models

- 1 model of the hydrogen (H) atom
- 2 atomic nucleus, a proton
- 3 electron
- 4 electron spin
- 5 model of the helium (He) atom
- 6 electron shell
- 7 Pauli exclusion principle (exclusion principle, Pauli principle)
- 8 complete electron shell of the Na atom (sodium atom)

9-14 molecular structures (lattice structures)

- 9 crystal of sodium chloride (of common salt)
- 10 chlorine ion
- 11 sodium ion
- 12 crystal of cristobalite
- 13 oxygen atom
- 14 silicon atom

15 energy level diagram (term diagram, possible quantum jumps) of the hydrogen atom

- 16 atomic nucleus (proton)
- 17 electron
- 18 ground state level
- 19 excited state

20-25 quantum jumps (quantum transitions)

- 20 Lyman series
- 21 Balmer series
- 22 Paschen series
- 23 Brackett series
- 24 Pfund series
- 25 free electron
- 26 Bohr-Sommerfeld model of the H atom

27 electron orbits of the electron

28 spontaneous decay of radioactive material

- 29 atomic nucleus
- 30, 31 alpha (α) particle (alpha ray, helium nucleus)
- 30 neutron
- 31 proton
- 32 beta (β) particle (beta ray, electron)

33 gamma (γ) ray, a hard X-ray

34 nuclear fission

- 35 heavy atomic nucleus
- 36 neutron bombardment
- 37, 38 fission fragments
- 39 released neutron
- 40 gamma (γ) ray

41 chain reaction

- 42 incident neutron
- 43 nucleus prior to fission
- 44 fission fragment
- 45 released neutron
- 46 repeated fission
- 47 fission fragment

48 controlled chain reaction in a nuclear reactor

- 49 atomic nucleus of a fissionable element
- 50 neutron bombardment
- 51 fission fragment (new atomic nucleus)

- 52 released neutron
- 53 absorbed neutrons
- 54 moderator, a retarding layer of graphite
- 55 extraction of heat (production of energy)

56 X-ray

57 concrete and lead shield

58 bubble chamber for showing the tracks of high-energy ionizing particles

59 light source

60 camera

61 expansion line

62 path of light rays

63 magnet

64 beam entry point

65 reflector

66 chamber

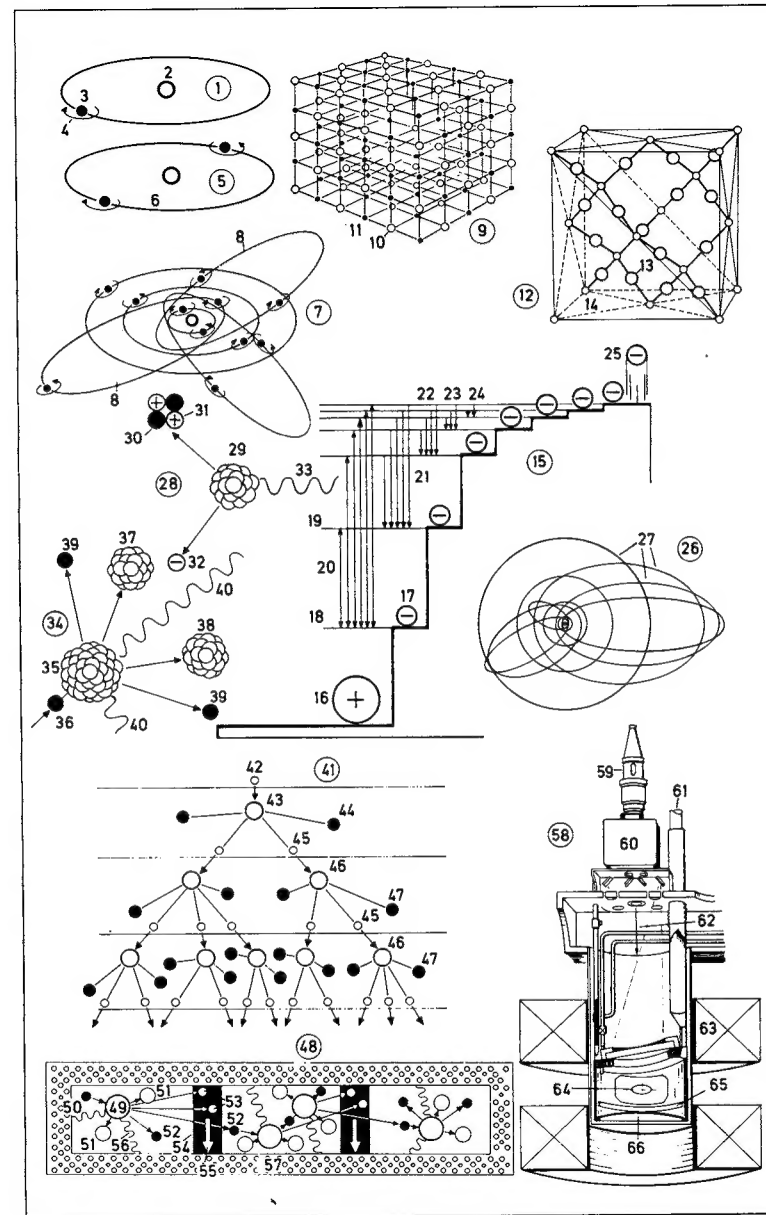

- 1-23 radiation detectors** (radiation meters)
- 1 radiation monitor
 - 2 ionization chamber (ion chamber)
 - 3 central electrode
 - 4 measurement range selector
 - 5 instrument housing
 - 6 meter
 - 7 zero adjustment
- 8-23 dosimeter** (dosemeter)
- 8 film dosimeter
 - 9 filter
 - 10 film
 - 11 film-ring dosimeter
 - 12 filter
 - 13 film
 - 14 cover with filter
 - 15 pocket meter (pen meter, pocket chamber)
 - 16 window
 - 17 ionization chamber (ion chamber)
 - 18 clip (pen clip)
 - 19 Geiger counter (Geiger-Müller counter)
 - 20 counter tube casing
 - 21 counter tube
 - 22 instrument housing
 - 23 measurement range selector
- 24 Wilson cloud chamber** (Wilson chamber)
- 25 compression plate
 - 26 cloud chamber photograph
 - 27 cloud chamber track of an alpha particle
- 28 telecobalt unit** (*coll. cobalt bomb*)
- 29 pillar stand
 - 30 support cables
 - 31 radiation shield (radiation shielding)
 - 32 sliding shield
 - 33 bladed diaphragm
 - 34 light-beam positioning device
 - 35 pendulum device (pendulum)
 - 36 irradiation table
 - 37 rail (track)
 - 38 **manipulator with sphere unit**

- 39 handle
- 40 safety catch (locking lever)
- 41 wrist joint
- 42 master arm
- 43 clamping device (clamp)
- 44 tongs
- 45 slotted board
- 46 radiation shield (protective shield, protective shielding), a lead shielding wall [section]
- 47 grasping arm of a pair of manipulators (of a master/slave manipulator)
- 48 dust shield
- 49 **synchrotron**
- 50 danger zone
- 51 magnet
- 52 pumps for emptying the vacuum chamber

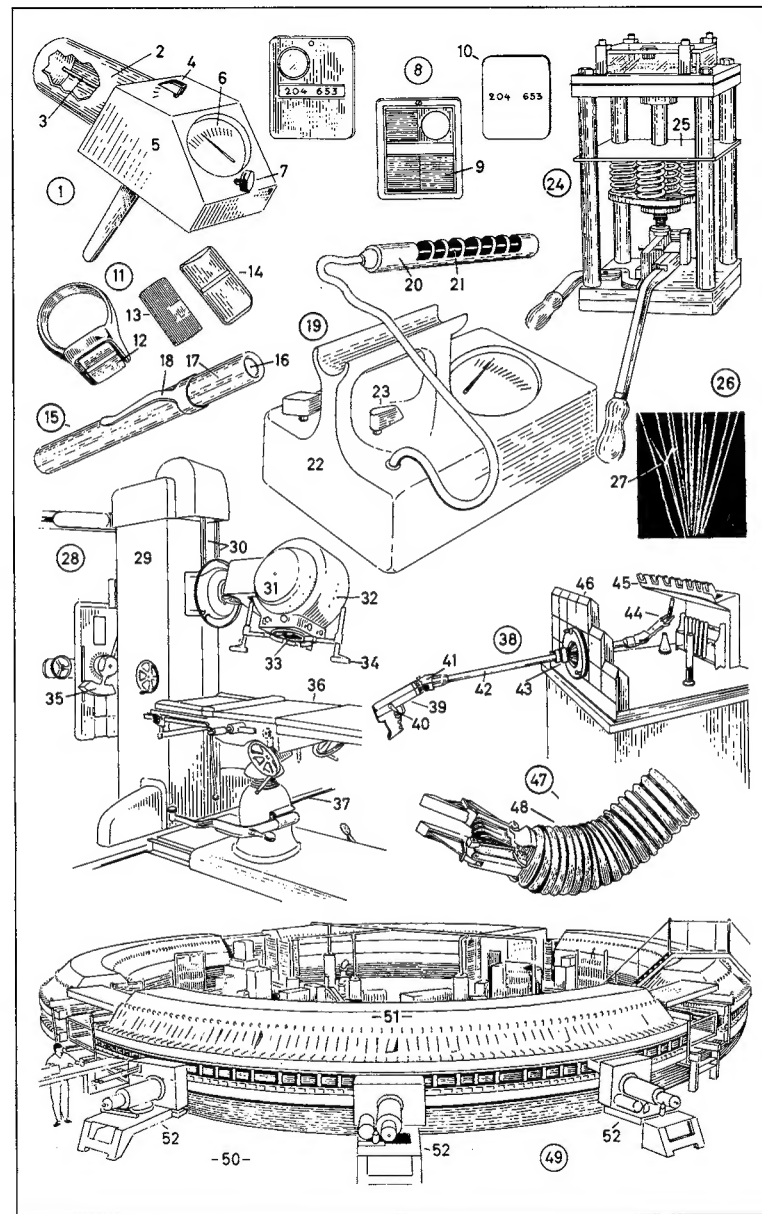

1-35 star map of the northern sky

(northern hemisphere)

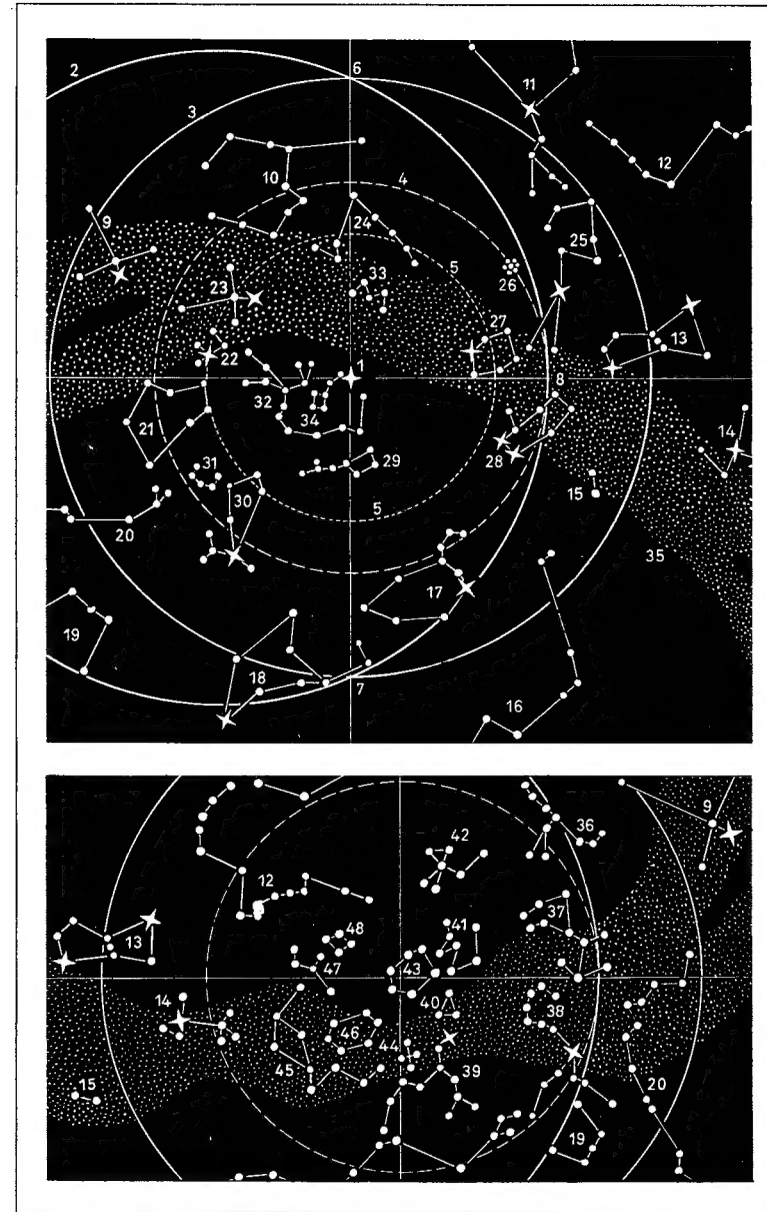
1-8 divisions of the sky**1** celestial pole with the Pole Star (Polaris, the North Star)**2** ecliptic (apparent annual path of the sun)**3** celestial equator (equinoctial line)**4** tropic of Cancer**5** circle enclosing circumpolar stars**6, 7** equinoctial points (equinoxes)**6** vernal equinoctial point (first point of Aries)**7** autumnal equinoctial point**8** summer solstice**9-48 constellations (grouping of fixed stars into figures) and names of stars****9** Aquila (the Eagle) with Altair the principal star (the brightest star)**10** Pegasus (the Winged Horse)**11** Cetus (the Whale) with Mira, a variable star**12** Eridanus (the Celestial River)**13** Orion (the Hunter) with Rigel, Betelgeuse and Bellatrix**14** Canis Major (the Great Dog, the Greater Dog) with Sirius (the Dog Star), a star of the first magnitude**15** Canis Minor (the Little Dog, the Lesser Dog) with Procyon**16** Hydra (the Water Snake, the Sea Serpent)**17** Leo (the Lion) with Regulus**18** Virgo (the Virgin) with Spica**19** Libra (the Balance, the Scales)**20** Serpens (the Serpent)**21** Hercules**22** Lyra (the Lyre) with Vega**23** Cygnus (the Swan, the Northern Cross) with Deneb**24** Andromeda**25** Taurus (the Bull) with Aldebaran**26** The Pleiades (Pleiads, the Seven Sisters), an open cluster of stars**27** Auriga (the Wagoner, the Charioteer) with Capella**28** Gemini (the Twins) with Castor and Pollux**29** Ursa Major (the Great Bear, the Greater Bear, the Plough, Charles's Wain, *Am.* the Big Dipper) with the double star (binary star) Mizar and Alcor**30** Boötes (the Herdsman) with Arcturus**31** Corona Borealis (the Northern Crown)**32** Draco (the Dragon)**33** Cassiopeia**34** Ursa Minor (the Little Bear, Lesser Bear, *Am.* Little Dipper) with the Pole Star (Polaris, the North Star)**35** the Milky Way (the Galaxy)**36-48 the southern sky****36** Capricorn (the Goat, the Sea Goat)**37** Sagittarius (the Archer)**38** Scorpio (the Scorpion)**39** Centaurus (the Centaur)**40** Triangulum Australe (the Southern Triangle)**41** Pavo (the Peacock)**42** Grus (the Crane)**43** Octans (the Octant)**44** Crux (the Southern Cross, the Cross)**45** Argo (the Celestial Ship)**46** Carina (the Keel)**47** Pictor (the Painter)**48** Reticulum (the Net)

4 Astronomy II

- 1-9 the moon
- 1 moon's path (moon's orbit round the earth)
- 2-7 lunar phases (moon's phases) (lunation)
- 2 new moon
- 3 crescent (crescent moon, waxing moon)
- 4 half-moon (first quarter)
- 5 full moon
- 6 half-moon (last quarter, third quarter)
- 7 crescent (crescent moon, waning moon)
- 8 the earth (terrestrial globe)
- 9 direction of the sun's rays
- 10-21 apparent path of the sun at the beginning of the seasons
- 10 celestial axis
- 11 zenith
- 12 horizontal plane
- 13 nadir
- 14 east point
- 15 west point
- 16 north point
- 17 south point
- 18 apparent path of the sun on 21 December
- 19 apparent path of the sun on 21 March and 23 September
- 20 apparent path of the sun on 21 June
- 21 border of the twilight area
- 22-28 rotary motions of the earth's axis
- 22 axis of the ecliptic
- 23 celestial sphere
- 24 path of the celestial pole [precession and nutation]
- 25 instantaneous axis of rotation
- 26 celestial pole
- 27 mean axis of rotation
- 28 polhode
- 29-35 solar and lunar eclipse [not to scale]
- 29 the sun
- 30 the earth
- 31 the moon

- 32 solar eclipse
- 33 area of the earth in which the eclipse appears total
- 34, 35 lunar eclipse
- 34 penumbra (partial shadow)
- 35 umbra (total shadow)
- 36-41 the sun
- 36 solar disc (disk) (solar globe, solar sphere)
- 37 sunspots
- 38 cyclones in the area of sunspots
- 39 corona (solar corona), observable during total solar eclipse or by means of special instruments
- 40 prominences (solar prominences)
- 41 moon's limb during a total solar eclipse
- 42-52 planets (planetary system, solar system) [not to scale] and planet symbols
- 42 the sun
- 43 Mercury
- 44 Venus
- 45 Earth, with the moon, a satellite
- 46 Mars, with two moons
- 47 asteroids (minor planets)
- 48 Jupiter
- 49 Saturn
- 50 Uranus
- 51 Neptune
- 52 Pluto, with the moon Charon
- 53-64 signs of the zodiac (zodiacal signs)
- 53 Aries (the Ram)
- 54 Taurus (the Bull)
- 55 Gemini (the Twins)
- 56 Cancer (the Crab)
- 57 Leo (the Lion)
- 58 Virgo (the Virgin)
- 59 Libra (the Balance, the Scales)
- 60 Scorpio (the Scorpion)
- 61 Sagittarius (the Archer)
- 62 Capricorn (the Goat, the Sea Goat)
- 63 Aquarius (the Water Carrier, the Water Bearer)
- 64 Pisces (the Fish)

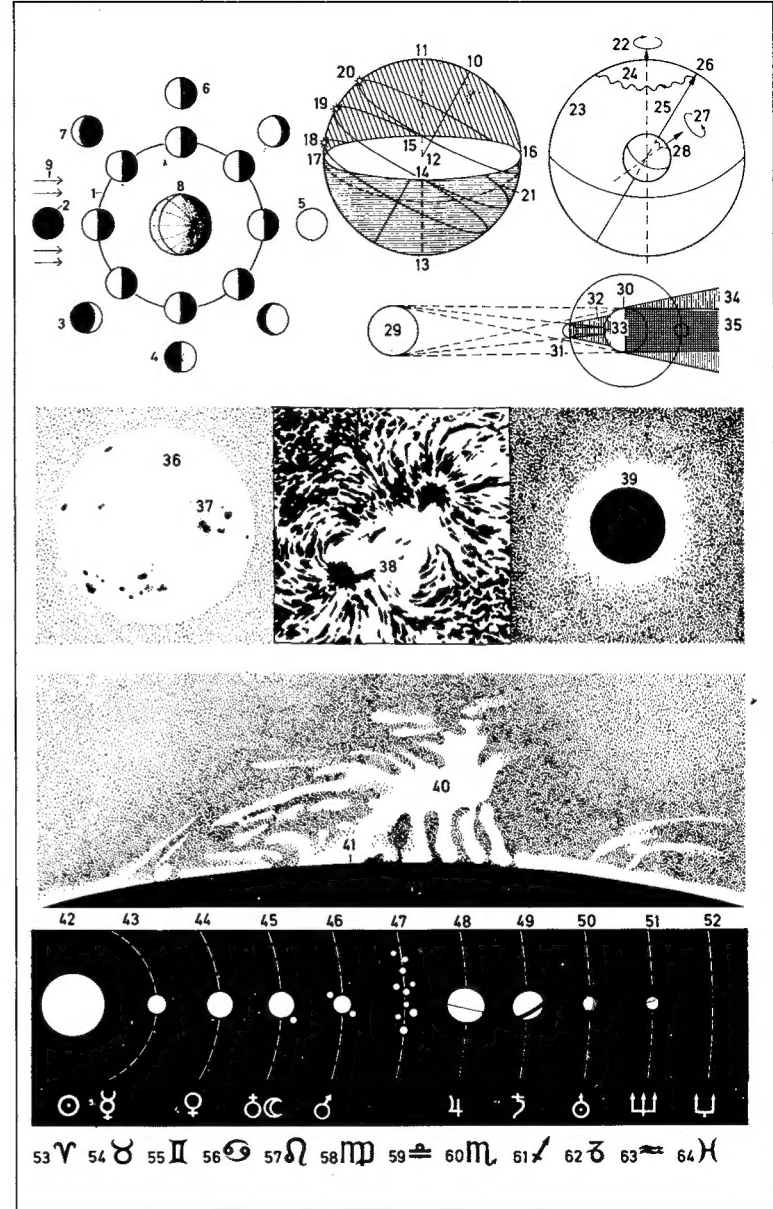

1-16 the European Southern

Observatory (ESO) on *Cerro la Silla, Chile*, an observatory [section]

- 1 primary mirror (main mirror) with a diameter of 3.6 m (144 inches)
- 2 prime focus cage with mounting for secondary mirrors
- 3 flat mirror for the coudé ray path
- 4 Cassegrain cage
- 5 grating spectrograph
- 6 spectrographic camera
- 7 hour axis drive
- 8 hour axis
- 9 horseshoe mounting
- 10 hydrostatic bearing
- 11 primary and secondary focusing devices
- 12 observatory dome, a revolving dome
- 13 observation opening
- 14 vertically movable dome shutter
- 15 wind screen
- 16 siderostat

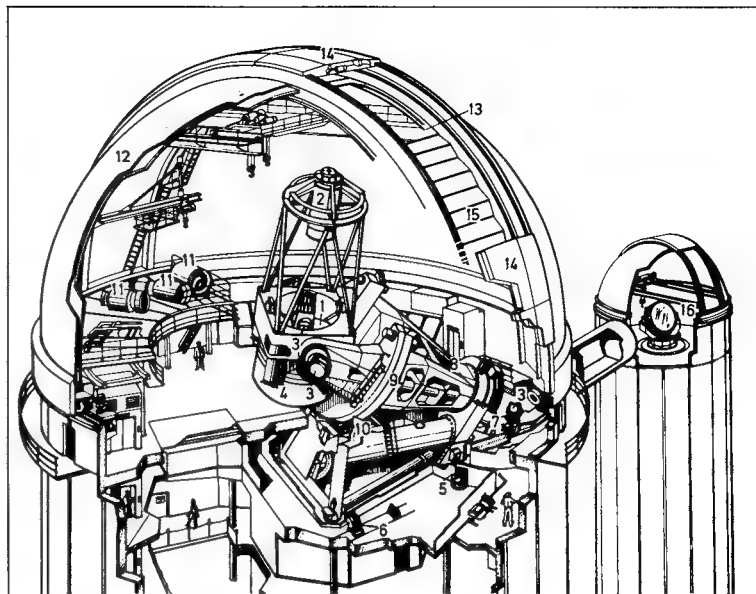
17-28 the *Stuttgart* Planetarium [section]

- 17 administration, workshop, and store area
- 18 steel scaffold
- 19 glass pyramid
- 20 revolving arched ladder
- 21 projection dome
- 22 light stop
- 23 planetarium projector
- 24 well
- 25 foyer
- 26 theatre (*Am. theater*)
- 27 projection booth
- 28 foundation pile

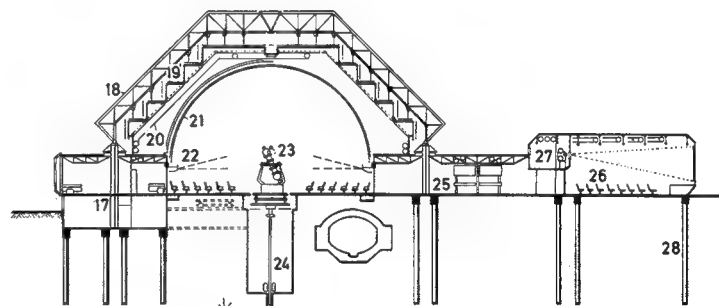
29-33 the *Kitt Peak* solar observatory near *Tucson, Ariz.* [section]

- 29 heliostat
- 30 sunken observation shaft
- 31 water-cooled windshield
- 32 concave mirror
- 33 observation room housing the spectrograph

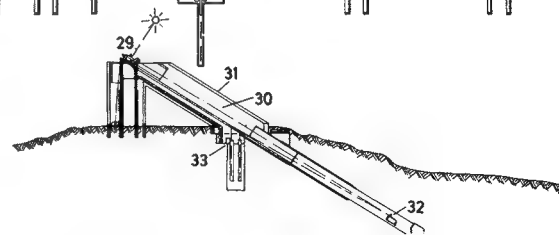

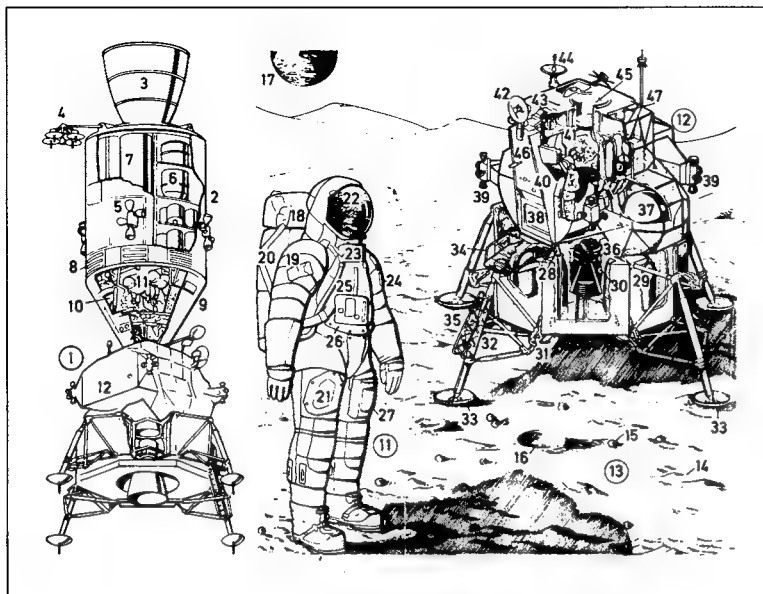

- | | |
|--|---|
| 1 Apollo spacecraft | 24 penlight pocket |
| 2 service module (SM) | 25 access flap for the purge valve |
| 3 nozzle of the main rocket engine | 26 tube and cable connections for the radio, ventilation, and water-cooling systems |
| 4 directional antenna | 27 pocket for pens, tools, etc. |
| 5 manoeuvring (<i>Am.</i> maneuvering) rockets | 28-36 descent stage |
| 6 oxygen and hydrogen tanks for the spacecraft's energy system | 28 connector |
| 7 fuel tank | 29 fuel tank |
| 8 radiators of the spacecraft's energy system | 30 engine |
| 9 command module (Apollo space capsule) | 31 mechanism for unfolding the legs |
| 10 entry hatch of the space capsule | 32 main shock absorber |
| 11 astronaut | 33 landing pad |
| 12 lunar module (LM) | 34 ingress/egress platform (hatch platform) |
| 13 moon's surface (lunar surface), a dust-covered surface | 35 ladder to platform and hatch |
| 14 lunar dust | 36 cardan mount for engine |
| 15 piece of rock | 37-47 ascent stage |
| 16 meteorite crater | 37 fuel tank |
| 17 the earth | 38 ingress/egress hatch (entry/exit hatch) |
| 18-27 space suit (extra-vehicular suit) | 39 LM manoeuvring (<i>Am.</i> maneuvering) rockets |
| 18 emergency oxygen apparatus | 40 window |
| 19 sunglass pocket [with sunglasses for use on board] | 41 crew compartment |
| 20 life support system (life support pack), a backpack unit | 42 rendezvous radar antenna |
| 21 access flap | 43 inertial measurement unit |
| 22 space suit helmet with sun filters | 44 directional antenna for ground control |
| 23 control box of the life support pack | 45 upper hatch (docking hatch) |
| | 46 inflight antenna |
| | 47 docking target recess |

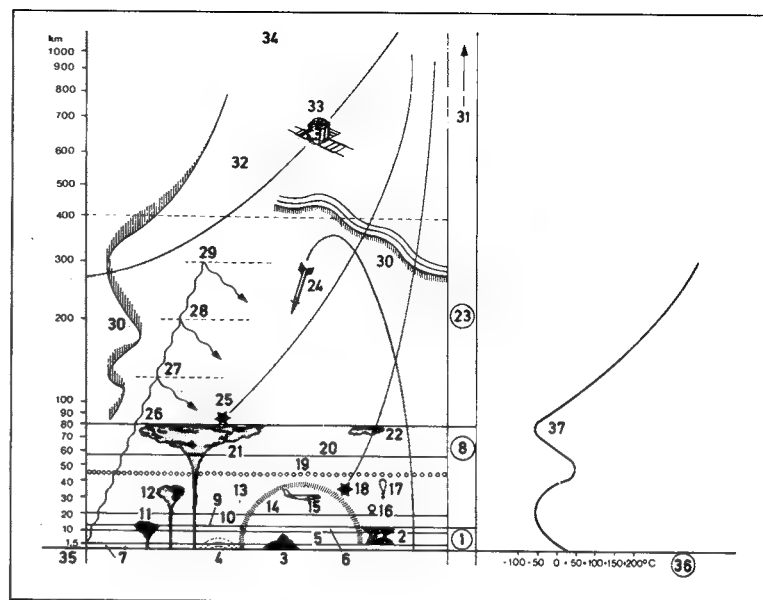

- | | |
|--|---|
| 1 the troposphere | 20 zero level |
| 2 thunderclouds | 21 eruption of Krakatoa |
| 3 the highest mountain, <i>Mount Everest</i> [8,882 m] | 22 luminous clouds (noctilucent clouds) |
| 4 rainbow | 23 the ionosphere |
| 5 jet stream level | 24 range of research rockets |
| 6 zero level [inversion of vertical air movement] | 25 shooting star |
| 7 ground layer (surface boundary layer) | 26 short wave (high frequency) |
| 8 the stratosphere | 27 E-layer (Heaviside-Kennelly Layer) |
| 9 tropopause | 28 F ₁ -layer |
| 10 separating layer (layer of weaker air movement) | 29 F ₂ -layer |
| 11 atomic explosion | 30 aurora (polar light) |
| 12 hydrogen bomb explosion | 31 the exosphere |
| 13 ozone layer | 32 atom layer |
| 14 range of sound wave propagation | 33 range of satellite sounding |
| 15 stratosphere aircraft | 34 fringe region |
| 16 manned balloon | 35 altitude scale |
| 17 sounding balloon | 36 temperature scale (thermometric scale) |
| 18 meteor | 37 temperature graph |
| 19 upper limit of ozone layer | |

8 Meteorology I

1-19 clouds and weather

1-4 clouds found in homogeneous air masses

- 1 cumulus (woolpack cloud), a heap cloud; *here*: cumulus humilis (fair-weather cumulus), a flat-based heap cloud
- 2 cumulus congestus, a heap cloud with more marked vertical development
- 3 stratocumulus, a layer cloud (sheet cloud) arranged in heavy masses
- 4 stratus (high fog), a thick, uniform layer cloud (sheet cloud)

5-12 clouds found at warm fronts

- 5 warm front
- 6 cirrus, a high to very high ice-crystal cloud, thin and assuming a wide variety of forms
- 7 cirrostratus, an ice-crystal cloud veil
- 8 altostratus, a layer cloud (sheet cloud) of medium height
- 9 altostratus praecipitans, a layer cloud (sheet cloud) with precipitation in its upper parts
- 10 nimbostratus, a rain cloud, a layer cloud (sheet cloud) of very large vertical extent which produces precipitation (rain or snow)
- 11 fractostratus, a ragged cloud occurring beneath nimbostratus
- 12 fractocumulus, a ragged cloud like 11 but with billowing shapes

13-17 clouds at cold fronts

- 13 cold front
- 14 cirrocumulus, thin fleecy cloud in the form of globular masses; *covering the sky*: mackerel sky
- 15 altocumulus, a cloud in the form of large globular masses
- 16 altocumulus castellanus and altocumulus floccus, species of 15
- 17 cumulonimbus, a heap cloud of very large vertical extent, to be classified under 1-4 in the case of tropical storms

18-19 types of precipitation

- 18 steady rain or snow covering a large area, precipitation of uniform intensity
- 19 shower, scattered precipitation

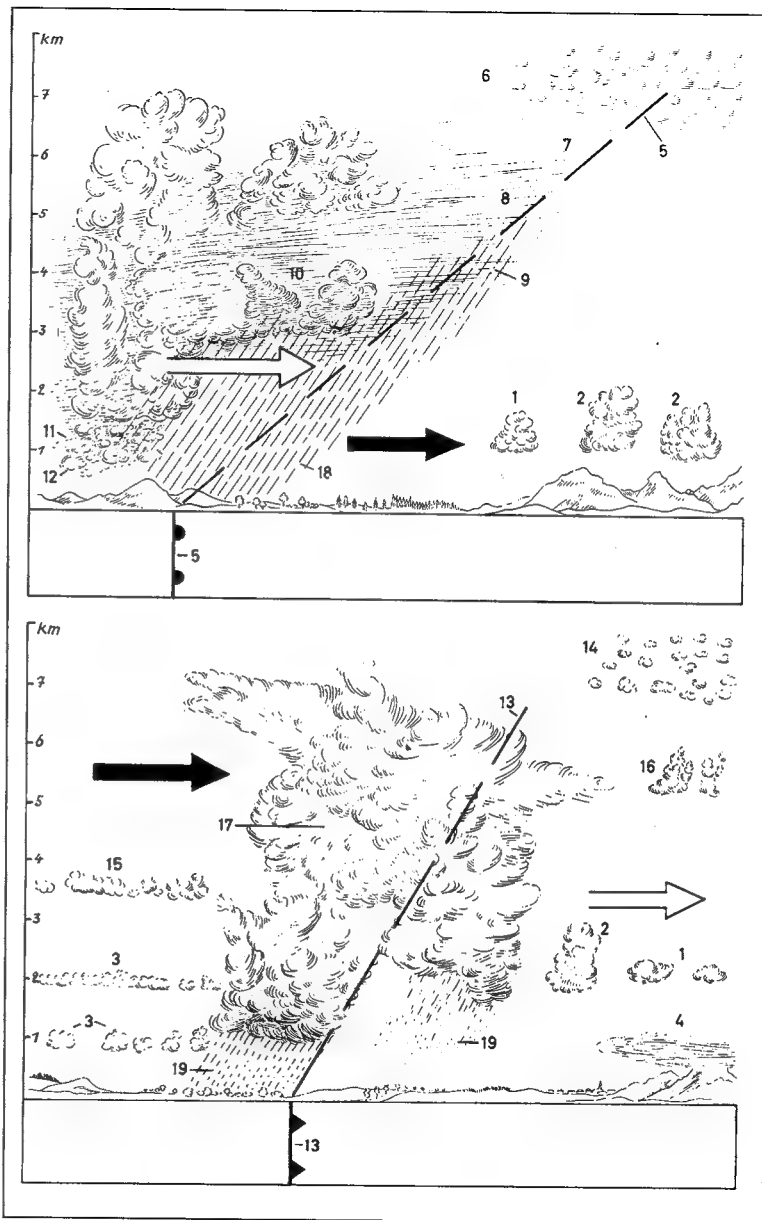

black arrow = cold air white arrow = warm air

1-39 weather chart (weather map, surface chart, surface synoptic chart)

1 isobar (line of equal or constant atmospheric or barometric pressure at sea level)

2 pleiobar (isobar of over 1,000 mb)

3 meiobar (isobar of under 1,000 mb)

4 atmospheric (barometric) pressure given in millibars

5 low-pressure area (low, cyclone, depression)

6 high-pressure area (high, anticyclone)

7 observatory (meteorological watch office, weather station) or ocean station vessel (weather ship)

8 temperature

9-19 means of representing wind direction (wind-direction symbols)

9 wind-direction shaft (wind arrow)

10 wind-speed barb (wind-speed feather) indicating wind speed

11 calm

12 1-2 knots (1 knot = 1.852 kph)

13 3-7 knots

14 8-12 knots

15 13-17 knots

16 18-22 knots

17 23-27 knots

18 28-32 knots

19 58-62 knots

20-24 state of the sky (distribution of the cloud cover)

20 clear (cloudless)

21 fair

22 partly cloudy

23 cloudy

24 overcast (sky mostly or completely covered)

25-29 fronts and air currents

25 occlusion (occluded front)

26 warm front

27 cold front

28 warm airstream (warm current)

29 cold airstream (cold current)

30-39 meteorological phenomena

30 precipitation area

31 fog

32 rain

33 drizzle

34 snow

35 ice pellets (graupel, soft hail)

36 hail

37 shower

38 thunderstorm

39 lightning

40-58 climatic map

40 isotherm (line connecting points having equal mean temperature)

41 0 ° C (zero) isotherm (line connecting points having a mean annual temperature of 0 ° C)

42 isocheim (line connecting points having equal mean winter temperature)

43 isother (line connecting points having equal mean summer temperature)

44 isohel (line connecting points having equal duration of sunshine)

45 isohyet (line connecting points having equal amounts of precipitation)

46-52 atmospheric circulation (wind systems)

46-47 calm belts

46 equatorial trough (equatorial calms, doldrums)

47 subtropical high-pressure belts (horse latitudes)

48 north-east trade winds (north-east trades, tropical easterlies)

49 south-east trade winds (south-east trades, tropical easterlies)

50 zones of the variable westerlies

51 polar wind zones

52 summer monsoon

53-58 earth's climates

53 equatorial climate: tropical zone (tropical rain zone)

54 the two arid zones (equatorial dry zones): desert and steppe zones

55 the two temperate rain zones

56 boreal climate (snow forest climate)

57, 58 polar climates

57 tundra climate

58 perpetual frost climate

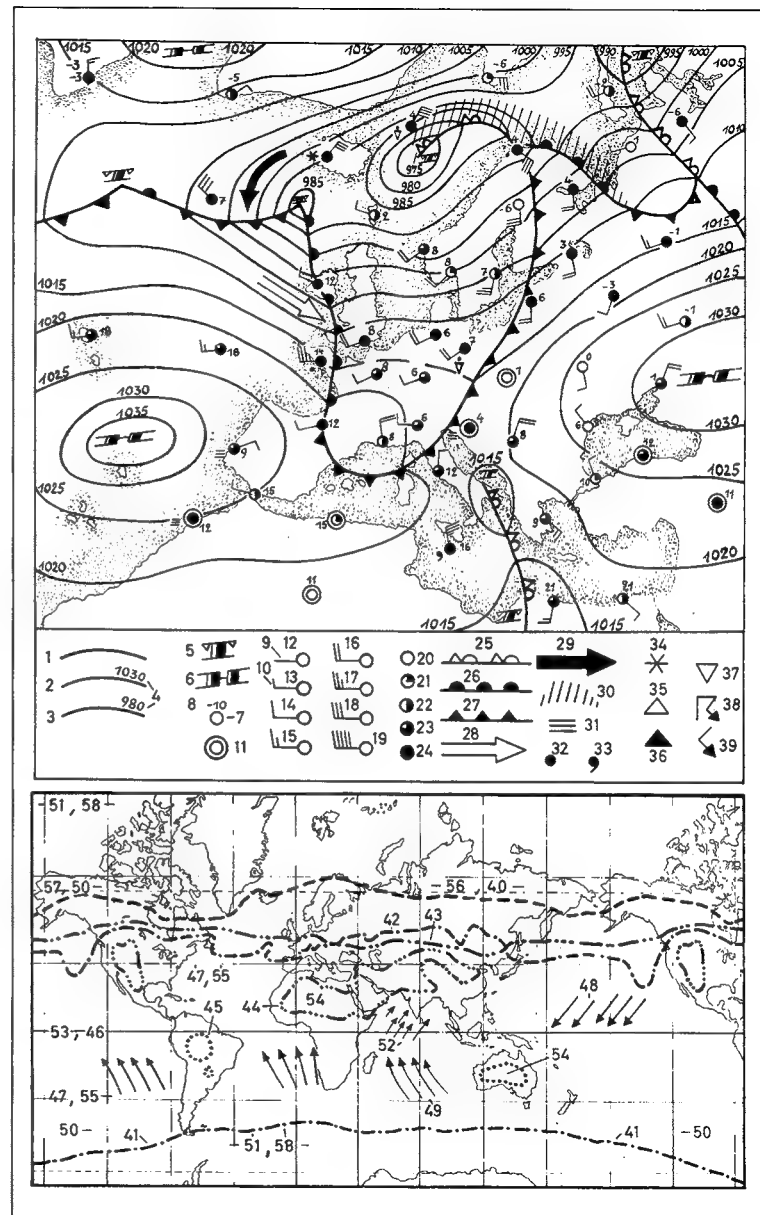

- 1 mercury barometer, a siphon barometer, a liquid-column barometer
- 2 mercury column
- 3 millibar scale, a millimetre (*Am.* millimeter) scale
- 4 barograph, a self-registering aneroid barometer
- 5 drum (recording drum)
- 6 bank of aneroid capsules (aneroid boxes)
- 7 recording arm
- 8 hygrograph
- 9 hygrometer element (hair element)
- 10 reading adjustment
- 11 amplitude adjustment
- 12 recording arm
- 13 recording pen
- 14 change gears for the clockwork drive
- 15 off switch for the recording arm
- 16 drum (recording drum)
- 17 time scale
- 18 case (housing)
- 19 thermograph
- 20 drum (recording drum)
- 21 recording arm
- 22 sensing element
- 23 silver-disc (silver-disk) pyrhe-liometer, an instrument for measuring the sun's radiant energy
- 24 silver disc (disk)
- 25 thermometer
- 26 wooden insulating casing
- 27 tube with diaphragm (diaphragmed tube)
- 28 wind gauge (*Am.* gage) (anemo-meter)
- 29 wind-speed indicator (wind-speed meter)
- 30 cross arms with hemispherical cups
- 31 wind-direction indicator
- 32 wind vane
- 33 aspiration psychrometer
- 34 dry bulb thermometer
- 35 wet bulb thermometer
- 36 solar radiation shielding

- 37 suction tube
- 38 recording rain gauge (*Am.* gage)
- 39 protective housing (protective casing)
- 40 collecting vessel
- 41 rain cover
- 42 recording mechanism
- 43 siphon tube
- 44 precipitation gauge (*Am.* gage) (rain gauge)
- 45 collecting vessel
- 46 storage vessel
- 47 measuring glass
- 48 insert for measuring snowfall
- 49 thermometer screen (thermometer shelter)
- 50 hygrograph
- 51 thermograph
- 52 psychrometer (wet and dry bulb thermometer)
- 53, 54 thermometers for measuring extremes of temperature
- 53 maximum thermometer
- 54 minimum thermometer
- 55 radiosonde assembly
- 56 hydrogen balloon
- 57 parachute
- 58 radar reflector with spacing lines
- 59 instrument housing with radiosonde [a short-wave transmitter] and antenna
- 60 transmissometer, an instrument for measuring visibility
- 61 recording instrument (recorder)
- 62 transmitter
- 63 receiver
- 64 weather satellite (ITOS satellite)
- 65 temperature regulation flaps
- 66 solar panel
- 67 television camera
- 68 antenna
- 69 solar sensor (sun sensor)
- 70 telemetry antenna
- 71 radiometer

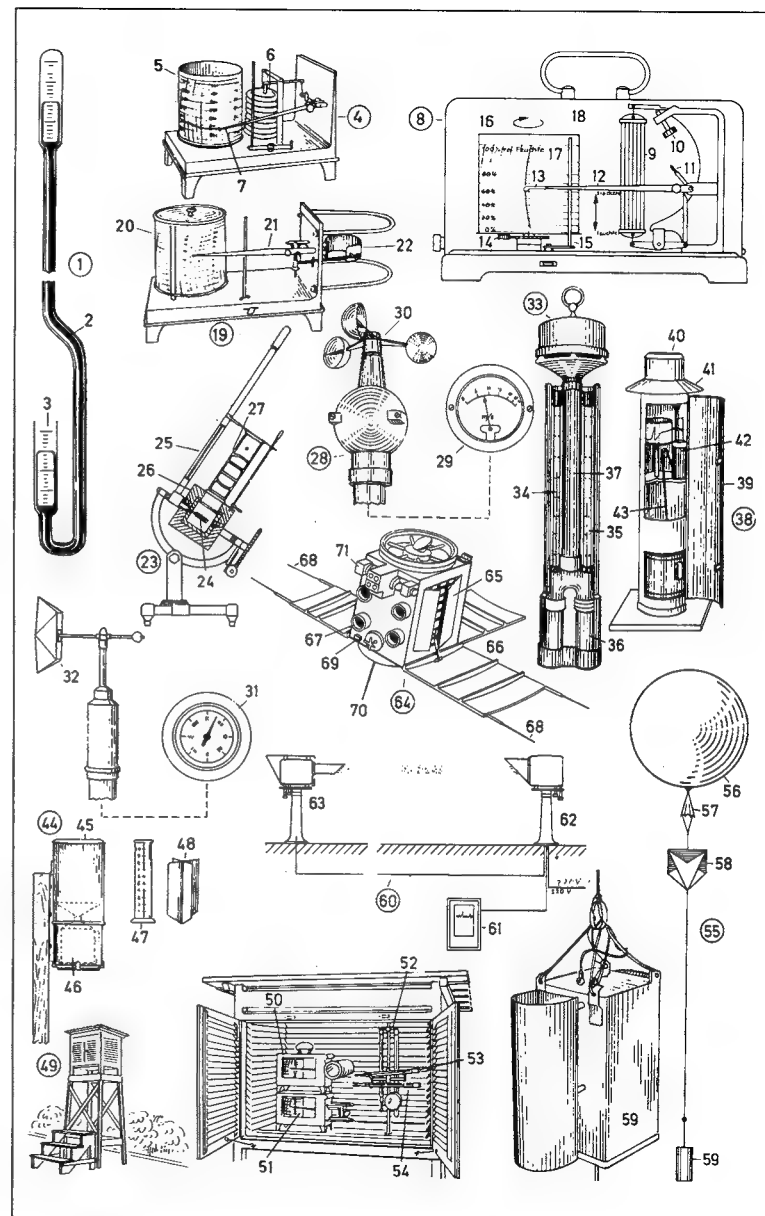

1-5 layered structure of the earth

- 1 earth's crust (outer crust of the earth, lithosphere, oxysphere)
- 2 hydrosphere
- 3 mantle
- 4 sima (intermediate layer)
- 5 core (earth core, centrosphere, barysphere)

6-12 hypsographic curve of the earth's surface

- 6 peak
- 7 continental mass
- 8 continental shelf (continental platform, shelf)
- 9 continental slope
- 10 deep-sea floor (abyssal plane)
- 11 sea level
- 12 deep-sea trench

13-28 volcanism (vulcanicity)

- 13 shield volcano
- 14 lava plateau
- 15 active volcano, a stratovolcano (composite volcano)
- 16 volcanic crater (crater)
- 17 volcanic vent
- 18 lava stream
- 19 tuff (fragmented volcanic material)
- 20 subterranean volcano
- 21 geyser
- 22 jet of hot water and steam
- 23 sinter terraces (siliceous sinter terraces, fiorite terraces, pearl sinter terraces)
- 24 cone
- 25 maar (extinct volcano)
- 26 tuff deposit
- 27 breccia
- 28 vent of extinct volcano

29-31 plutonic magmatism

- 29 batholite (massive protrusion)
- 30 lacolith, an intrusion
- 31 sill, an ore deposit

32-38 earthquake (kinds: tectonic quake, volcanic quake) and seismology

- 32 earthquake focus (seismic focus, hypocentre, *Am.* hypocenter)

33 epicentre (*Am.* epicenter), point on the earth's surface directly above the focus

- 34 depth of focus
- 35 shock wave
- 36 surface waves (seismic waves)
- 37 isoseismal (line connecting points of equal intensity of earthquake shock)
- 38 epicentral area, an area of macroseismic vibration
- 39 horizontal seismograph (seismometer)
- 40 electromagnetic damper
- 41 adjustment knob for the period of free oscillation of the pendulum
- 42 spring attachment for the suspension of the pendulum
- 43 mass
- 44 induction coils for recording the voltage of the galvanometer

45-54 effects of earthquakes

- 45 waterfall (cataract, falls)
- 46 landslide (rockslide, landslip, *Am.* rock slip)
- 47 talus (rubble, scree)
- 48 scar (scaur, scaw)
- 49 sink (sinkhole, swallowhole)
- 50 dislocation (displacement)
- 51 solifluction lobe (solifluction tongue)
- 52 fissure
- 53 tsunami (seismic sea wave) produced by seaquake (submarine earthquake)
- 54 raised beach

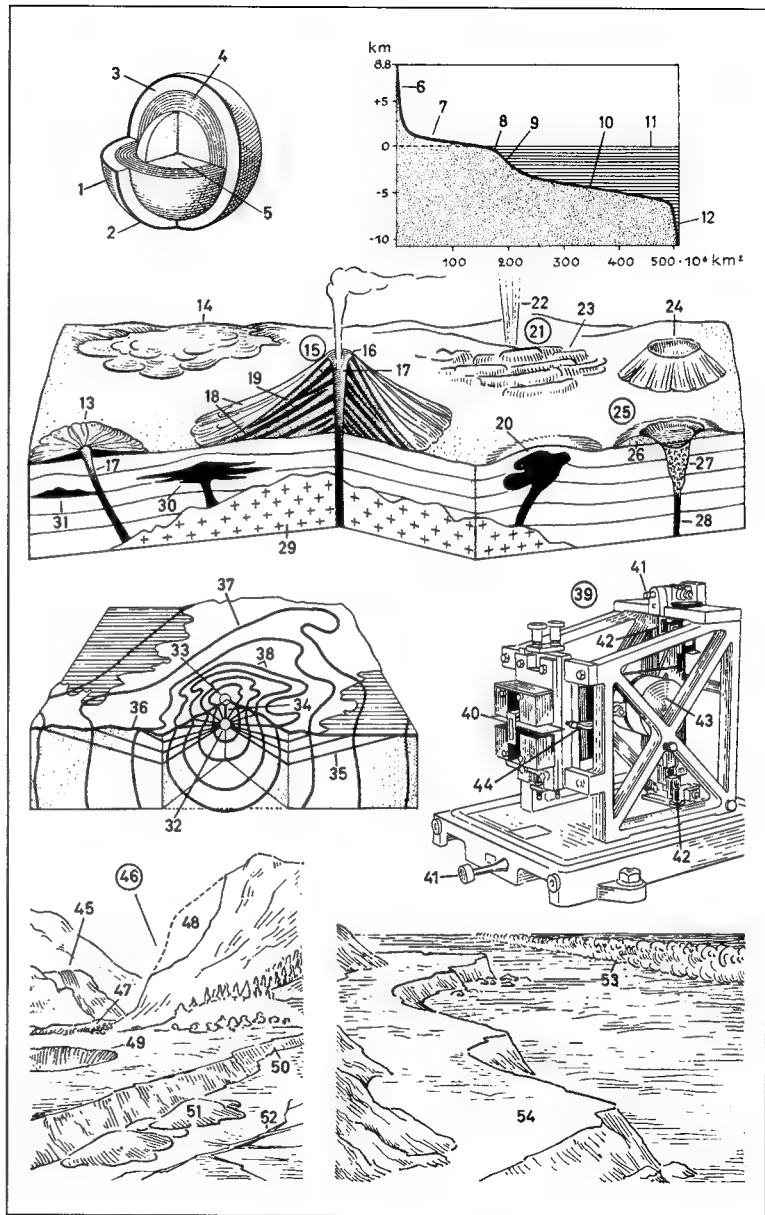

- 1-33 geology
- 1 stratification of sedimentary rock
- 2 strike
- 3 dip (angle of dip, true dip)
- 4-20 orogeny (orogenis, tectogenis, deformation of rocks by folding and faulting)
- 4-11 fault-block mountain (block mountain)
- 4 fault
- 5 fault line (fault trace)
- 6 fault throw
- 7 normal fault (gravity fault, normal slip fault, slump fault)
- 8-11 complex faults
- 8 step fault (distributive fault, multiple fault)
- 9 tilt block
- 10 horst
- 11 graben
- 12-20 range of fold mountains (folded mountains)
- 12 symmetrical fold (normal fold)
- 13 asymmetrical fold
- 14 overfold
- 15 recumbent fold (reclined fold)
- 16 saddle (anticline)
- 17 anticlinal axis
- 18 trough (syncline)
- 19 trough surface (trough plane, synclinal axis)
- 20 anticlinorium
- 21 groundwater under pressure (artesian water)
- 22 water-bearing stratum (aquifer, aquafer)
- 23 impervious rock (impermeable rock)
- 24 drainage basin (catchment area)
- 25 artesian well
- 26 rising water, an artesian spring
- 27 petroleum reservoir in an anticline
- 28 impervious stratum (impermeable stratum)
- 29 porous stratum acting as reservoir rock
- 30 natural gas, a gas cap

- 31 petroleum (crude oil)
- 32 underlying water
- 33 derrick
- 34 mountainous area
- 35 rounded mountain top
- 36 mountain ridge (ridge)
- 37 mountain slope
- 38 hillside spring
- 39-47 high-mountain region
- 39 mountain range, a massif
- 40 summit (peak, top of the mountain)
- 41 shoulder
- 42 saddle
- 43 rock face (steep face)
- 44 gully
- 45 talus (scree, detritus)
- 46 bridle path
- 47 pass (col)
- 48-56 glacial ice
- 48 firn field (firn basin, nevé)
- 49 valley glacier
- 50 crevasse
- 51 glacier snout
- 52 subglacial stream
- 53 lateral moraine
- 54 medial moraine
- 55 end moraine
- 56 glacier table

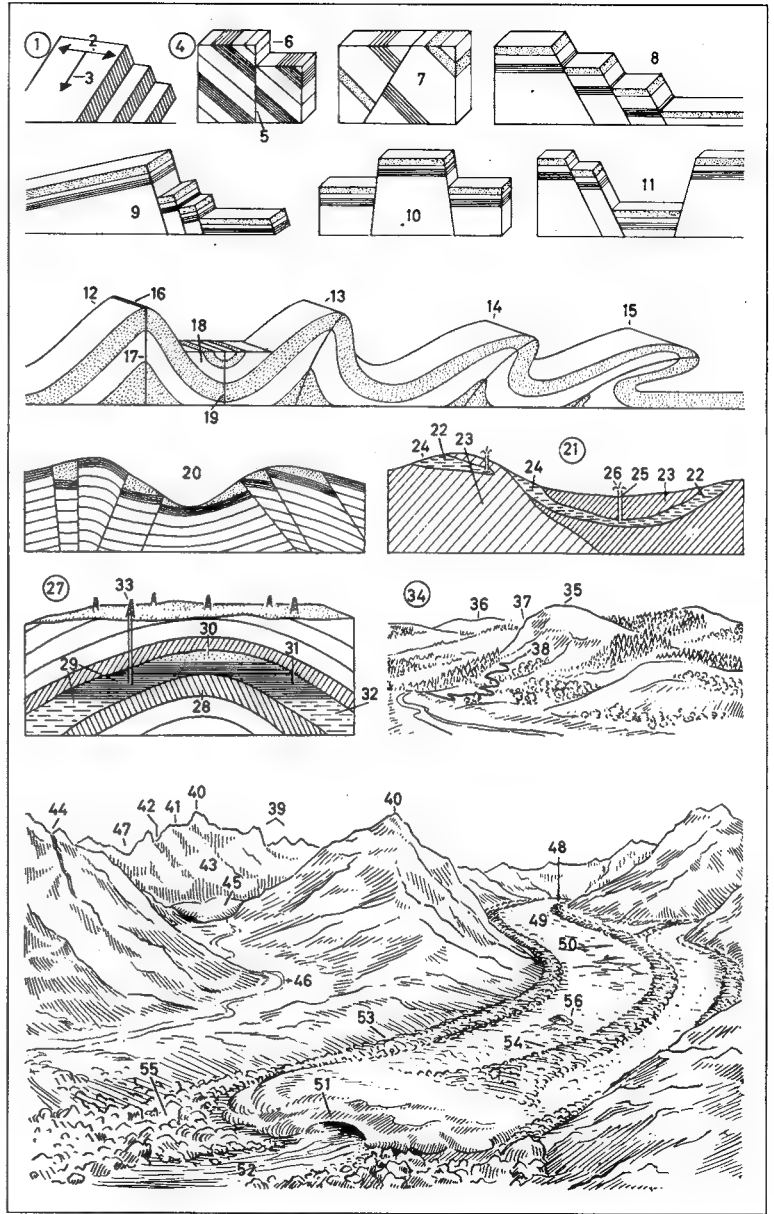

1-13 fluvial topography

- 1 river mouth, a delta
- 2 distributary (distributary channel), a river branch (river arm)
- 3 lake
- 4 bank
- 5 peninsula (spit)
- 6 island
- 7 bay (cove)
- 8 stream (brook, rivulet, creek)
- 9 levee
- 10 alluvial plain
- 11 meander (river bend)
- 12 meander core (rock island)
- 13 meadow
- 14-24 bog (marsh)
- 14 low-moor bog
- 15 layers of decayed vegetable matter
- 16 entrapped water
- 17 fen peat [consisting of rush and sedge]
- 18 alder-swamp peat
- 19 high-moor bog
- 20 layer of recent sphagnum mosses
- 21 boundary between layers (horizons)
- 22 layer of older sphagnum mosses
- 23 bog pool
- 24 swamp
- 25-31 **cliffline** (cliffs)
- 25 rock
- 26 sea (ocean)
- 27 surf
- 28 cliff (cliff face, steep rock face)
- 29 scree
- 30 [wave-cut] notch
- 31 abrasion platform (wave-cut platform)
- 32 atoll, a ring-shaped coral reef
- 33 lagoon
- 34 breach (hole)
- 35-44 beach
- 35 high-water line (high-water mark, tidemark)
- 36 waves breaking on the shore
- 37 groyne (*Am.* groin)
- 38 groyne (*Am.* groin) head
- 39 wandering dune (migratory dune, travelling, *Am.* traveling, dune), a dune
- 40 barchan (barchane, barkhan, crescentic dune)

- 41 ripple marks
- 42 hummock
- 43 wind cripple
- 44 coastal lake
- 45 **canyon** (cañon, coulee)
- 46 plateau (tableland)
- 47 rock terrace
- 48 sedimentary rock (stratified rock)
- 49 river terrace (bed)
- 50 joint
- 51 canyon river
- 52-56 **types of valley** [cross section]
- 52 gorge (ravine)
- 53 V-shaped valley (V-valley)
- 54 widened V-shaped valley
- 55 U-shaped valley (U-valley, trough valley)
- 56 synclinal valley
- 57-70 **river valley**
- 57 scarp (escarpment)
- 58 slip-off slope
- 59 mesa
- 60 ridge
- 61 river
- 62 flood plain
- 63 river terrace
- 64 terracette
- 65 pediment
- 66 hill
- 67 valley floor (valley bottom)
- 68 riverbed
- 69 sediment
- 70 bedrock
- 71-83 **karst formation in limestone**
- 71 dolina, a sink (sinkhole, swallow-hole)
- 72 polje
- 73 percolation of a river
- 74 karst spring
- 75 dry valley
- 76 system of caverns (system of caves)
- 77 water level (water table) in a karst formation
- 78 impervious rock (impermeable rock)
- 79 limestone cave (dripstone cave)
- 80, 81 speleothems (cave formations)
- 80 stalactite (dripstone)
- 81 stalagmite
- 82 linked-up stalagmite and stalactite
- 83 subterranean river

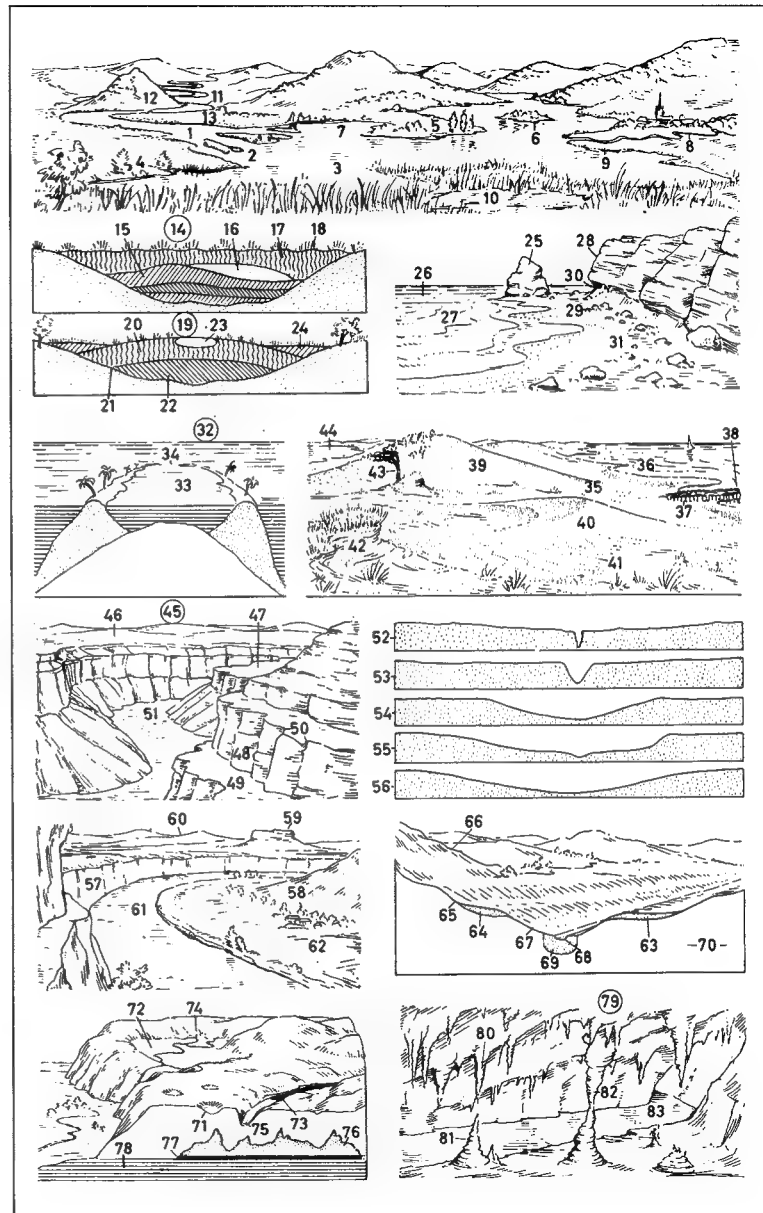

1-7 graticule of the earth (network of meridians and parallels on the earth's surface)

- 1 equator
- 2 line of latitude (parallel of latitude, parallel)
- 3 pole (North Pole or South Pole), a terrestrial pole (geographical pole)
- 4 line of longitude (meridian of longitude, meridian, terrestrial meridian)
- 5 Standard meridian (Prime meridian, Greenwich meridian, meridian of Greenwich)
- 6 latitude
- 7 longitude
- 8, 9 map projections**
- 8 conical (conic) projection
- 9 cylindrical projection (Mercator projection, Mercator's projection)

10-45 map of the world

- 10 tropics
- 11 polar circles
- 12-18 continents**
- 12, 13 America
- 12 North America
- 13 South America
- 14 Africa
- 15, 16 Europe and Asia
- 15 Europe
- 16 Asia
- 17 Australia
- 18 Antarctica (Antarctic Continent)
- 19-26 ocean (sea)**
- 19 Pacific Ocean
- 20 Atlantic Ocean
- 21 Arctic Ocean
- 22 Antarctic Ocean (Southern Ocean)
- 23 Indian Ocean
- 24 Strait of Gibraltar, a sea strait
- 25 Mediterranean (Mediterranean Sea, European Mediterranean)
- 26 North Sea, a marginal sea (epiric sea, epicontinental sea)
- 27-29 key (explanation of map symbols)**
- 27 cold ocean current
- 28 warm ocean current
- 29 scale
- 30-45 ocean (oceanic) currents** (ocean drifts)
- 30 Gulf Stream (North Atlantic Drift)

- 31 Kuroshio (Kuro Siwo, Japan Current)
- 32 North Equatorial Current
- 33 Equatorial Countercurrent
- 34 South Equatorial Current
- 35 Brazil Current
- 36 Somali Current
- 37 Agulhas Current
- 38 East Australian Current
- 39 California Current
- 40 Labrador Current
- 41 Canary Current
- 42 Peru Current
- 43 Benguela (Benguella) Current
- 44 West Wind Drift (Antarctic Circumpolar Drift)
- 45 West Australian Current
- 46-62 surveying** (land surveying, geodetic surveying, geodesy)
- 46 levelling (*Am.* leveling) (geometrical measurement of height)
- 47 graduated measuring rod (leveling, *Am.* leveling, staff)
- 48 level (surveying level, surveyor's level), a surveyor's telescope
- 49 triangulation station (triangulation point)
- 50 supporting scaffold
- 51 signal tower (signal mast)
- 52-62 theodolite, an instrument for measuring angles**
- 52 micrometer head
- 53 micrometer eyepiece
- 54 vertical tangent screw
- 55 vertical clamp
- 56 tangent screw
- 57 horizontal clamp
- 58 adjustment for the illuminating mirror
- 59 illuminating mirror
- 60 telescope
- 61 spirit level
- 62 circular adjustment
- 63-66 photogrammetry** (phototopography)
- 63 air survey camera for producing overlapping series of pictures
- 64 stereoscope
- 65 pantograph
- 66 stereoplanigraph

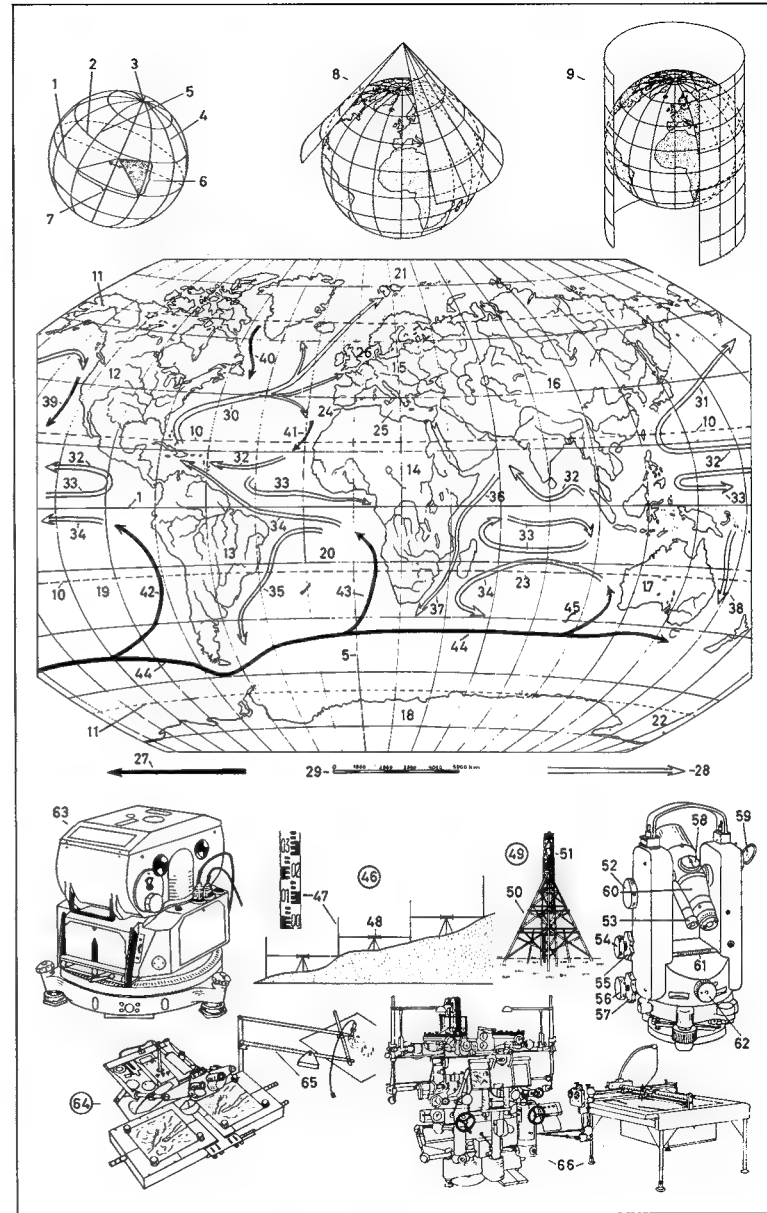

1-114 map signs (map symbols, conventional signs) on a 1:25 000 map

- | | |
|---|--|
| 1 coniferous wood (coniferous trees) | 47 vehicle ferry |
| 2 clearing | 48 mole |
| 3 forestry office | 49 beacon |
| 4 deciduous wood (non-coniferous trees) | 50 stone bridge |
| 5 heath (rough grassland, rough pasture, heath and moor, bracken) | 51 town or city |
| 6 sand or sand hills | 52 market place (market square) |
| 7 beach grass | 53 large church with two towers |
| 8 lighthouse | 54 public building |
| 9 mean low water | 55 road bridge |
| 10 beacon | 56 iron bridge |
| 11 submarine contours | 57 canal |
| 12 train ferry | 58 lock |
| 13 lightship | 59 jetty |
| 14 mixed wood (mixed trees) | 60 foot ferry (foot passenger ferry) |
| 15 brushwood | 61 chapel (church) without tower or spire |
| 16 motorway with slip road (<i>Am.</i> freeway with on-ramp, freeway with acceleration lane) | 62 contours |
| 17 trunk road | 63 monastery or convent |
| 18 grassland | 64 church landmark |
| 19 marshy grassland | 65 vineyard |
| 20 marsh | 66 weir |
| 21 main line railway (<i>Am.</i> trunk line) | 67 aerial ropeway |
| 22 road over railway | 68 view point |
| 23 branch line | 69 dam |
| 24 signal box (<i>Am.</i> switch tower) | 70 tunnel |
| 25 local line | 71 triangulation station (triangulation point) |
| 26 level crossing | 72 remains of a building |
| 27 halt | 73 wind pump |
| 28 residential area | 74 fortress |
| 29 water gauge (<i>Am.</i> gage) | 75 ox-bow lake |
| 30 good, metalled road | 76 river |
| 31 windmill | 77 watermill |
| 32 thorn house (graduation house, salina, salt-works) | 78 footbridge |
| 33 broadcasting station (wireless or television mast) | 79 pond |
| 34 mine | 80 stream (brook, rivulet, creek) |
| 35 disused mine | 81 water tower |
| 36 secondary road (B road) | 82 spring |
| 37 works | 83 main road (A road) |
| 38 chimney | 84 cutting |
| 39 wire fence | 85 cave |
| 40 bridge over railway | 86 lime kiln |
| 41 railway station (<i>Am.</i> railroad station) | 87 quarry |
| 42 bridge under railway | 88 clay pit |
| 43 footpath | 89 brickworks |
| 44 bridge for footpath under railway | 90 narrow-gauge (<i>Am.</i> narrow gauge) railway |
| 45 navigable river | 91 goods depot (freight depot) |
| 46 pontoon bridge | 92 monument |
| | 93 site of battle |
| | 94 country estate, a demesne |
| | 95 wall |
| | 96 stately home |
| | 97 park |
| | 98 hedge |

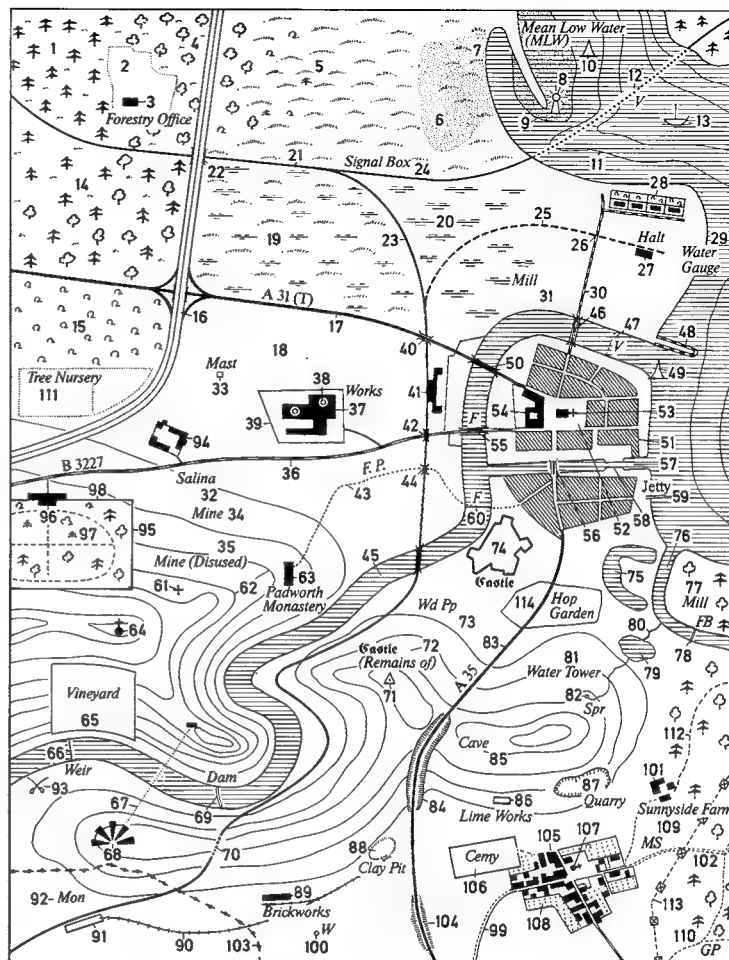

- | | |
|------------------------------------|--------------------------------------|
| 99 poor or unmetalled road | 110 guide post |
| 100 well | 111 tree nursery |
| 101 farm | 112 ride (aisle, lane, section line) |
| 102 unfenced path (unfenced track) | 113 electricity transmission line |
| 103 district boundary | 114 hop garden |
| 104 embankment | |
| 105 village | |
| 106 cemetery | |
| 107 church or chapel with spire | |
| 108 orchard | |
| 109 milestone | |

1-54 the human body

1-18 head

1 vertex (crown of the head, top of the head)

2 occiput (back of the head)

3 hair

4-17 face

4-5 forehead

4 frontal eminence (frontal protuberance)

5 superciliary arch

6 temple

7 eye

8 zygomatic bone (malar bone, jugal bone, cheekbone)

9 cheek

10 nose

11 nasolabial fold

12 philtrum

13 mouth

14 angle of the mouth (labial commissure)

15 chin

16 dimple (fossette) in the chin

17 jaw

18 ear

19-21 neck

19 throat

20 hollow of the throat

21 nape of the neck

22-41 trunk

22-25 back

22 shoulder

23 shoulderblade (scapula)

24 loins

25 small of the back

26 armpit

27 armpit hair

28-30 thorax (chest)

28-29 breasts (breast, mamma)

28 nipple

29 areola

30 bosom

31 waist

32 flank (side)

33 hip

34 navel

35-37 abdomen (stomach)

35 upper abdomen

36 abdomen

37 lower abdomen

38 groin

39 pudenda (vulva)

40 seat (backside, *coll.* bottom)

41 anal groove (anal cleft)

42 gluteal fold (gluteal furrow)

43-54 limbs

43-48 arm

43 upper arm

44 crook of the arm

45 elbow

46 forearm

47 hand

48 fist (clenched fist, clenched hand)

49-54 leg

49 thigh

50 knee

51 popliteal space

52 shank

53 calf

54 foot

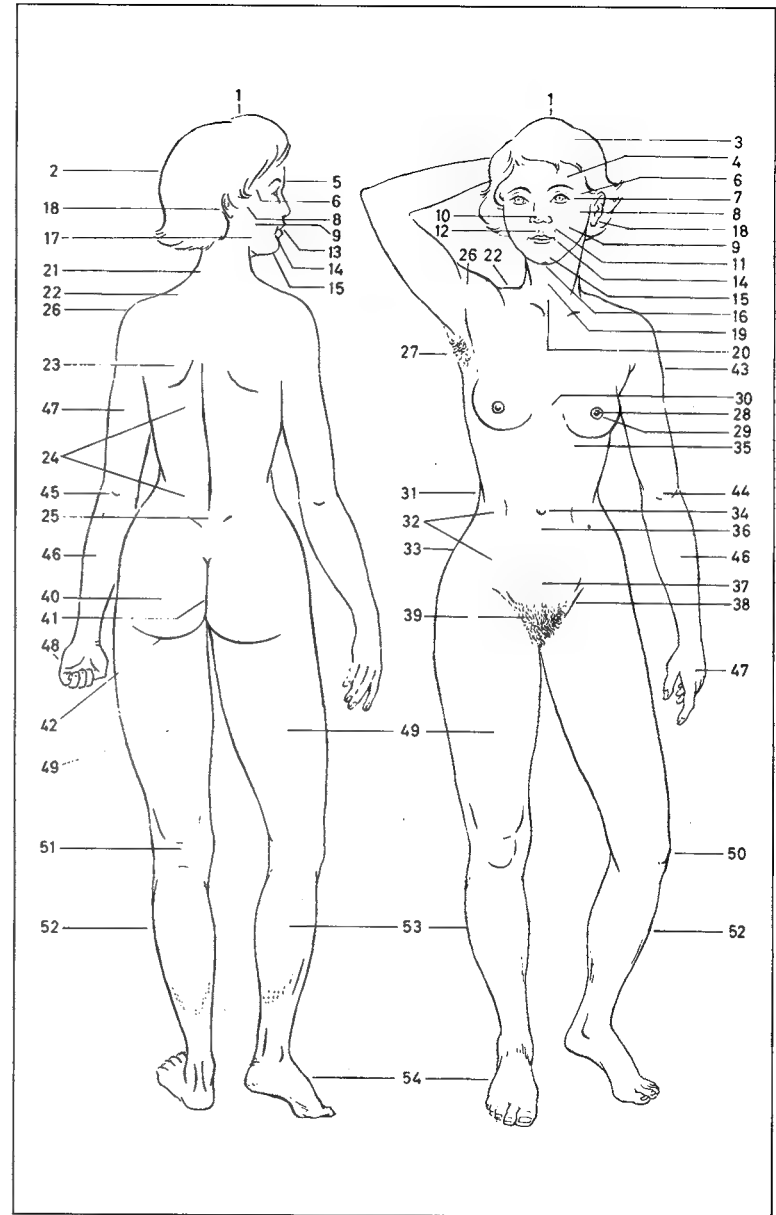

1-29 skeleton (bones)

- 1 skull
2-5 vertebral column (spinal column, spine, backbone)
 2 cervical vertebra
 3 dorsal vertebra (thoracic vertebra)
 4 lumbar vertebra
 5 coccyx (coccygeal vertebra)
6, 7 shoulder girdle
 6 collarbone (clavicle)
 7 shoulderblade (scapula)
8-11 thorax (chest)
 8 breastbone (sternum)
 9 true ribs
 10 false ribs
 11 costal cartilage
12-14 arm
 12 humerus
 13 radius
 14 ulna
15-17 hand
 15 carpus
 16 metacarpal bone (metacarpal)
 17 phalanx (phalange)
18-21 pelvis
 18 ilium (hip bone)
 19 ischium
 20 pubis
 21 sacrum
22-25 leg
 22 femur (thigh bone, thigh)
 23 patella (kneecap)
 24 fibula (splint bone)
 25 tibia (shinbone)
26-29 foot
 26 tarsal bones (tarsus)
 27 calcaneum (heelbone)
 28 metatarsus
 29 phalanges
30-41 skull
 30 frontal bone
 31 left parietal bone
 32 occipital bone
 33 temporal bone
 34 external auditory canal
 35 lower jawbone (lower jaw, mandible)

- 36 upper jawbone (upper jaw, maxilla)
 37 zygomatic bone (cheekbone)
 38 sphenoid bone (sphenoid)
 39 ethmoid bone (ethmoid)
 40 lacrimal (lacrimal) bone
 41 nasal bone
42-55 head [section]
 42 cerebrum (great brain)
 43 pituitary gland (pituitary body, hypophysis cerebri)
 44 corpus callosum
 45 cerebellum (little brain)
 46 pons (pons cerebri, pons cerebelli)
 47 medulla oblongata (brain stem)
 48 spinal cord
 49 oesophagus (esophagus, gullet)
 50 trachea (windpipe)
 51 epiglottis
 52 tongue
 53 nasal cavity
 54 sphenoidal sinus
 55 frontal sinus
56-65 organ of equilibrium and hearing
56-58 external ear
 56 auricle
 57 ear lobe
 58 external auditory canal
59-61 middle ear
 59 tympanic membrane
 60 tympanic cavity
 61 auditory ossicles: hammer, anvil, and stirrup (malleus, incus, and stapes)
62-64 inner ear (internal ear)
 62 labyrinth
 63 cochlea
 64 auditory nerve
 65 eustachian tube

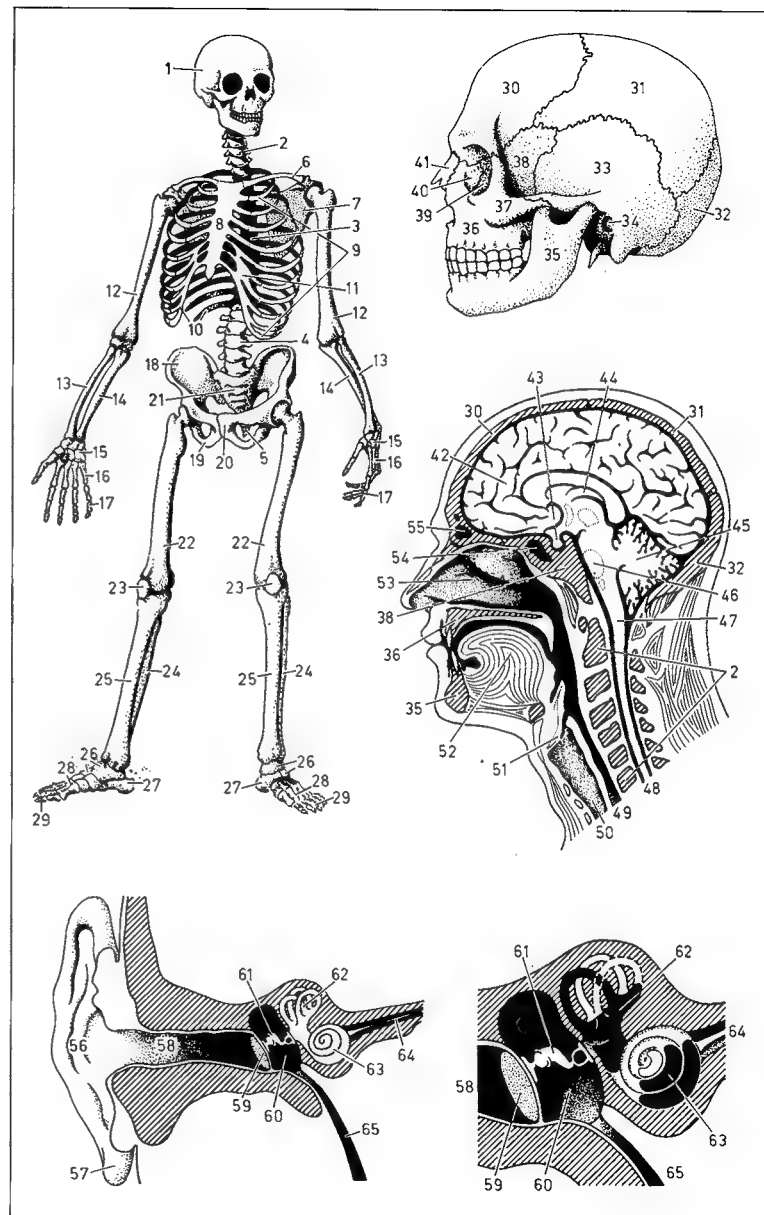

1-21 blood circulation (circulatory system)

- 1 common carotid artery, an artery
- 2 jugular vein, a vein
- 3 temporal artery
- 4 temporal vein
- 5 frontal artery
- 6 frontal vein
- 7 subclavian artery
- 8 subclavian vein
- 9 superior vena cava
- 10 arch of the aorta (aorta)
- 11 pulmonary artery [with venous blood]
- 12 pulmonary vein [with arterial blood]
- 13 lungs
- 14 heart
- 15 inferior vena cava
- 16 abdominal aorta (descending portion of the aorta)
- 17 iliac artery
- 18 iliac vein
- 19 femoral artery
- 20 tibial artery
- 21 radial artery

22-33 nervous system

- 22 cerebrum (great brain)
- 23 cerebellum (little brain)
- 24 medulla oblongata (brain stem)
- 25 spinal cord
- 26 thoracic nerves
- 27 brachial plexus
- 28 radial nerve
- 29 ulnar nerve
- 30 great sciatic nerve [lying posteriorly]
- 31 femoral nerve (anterior crural nerve)
- 32 tibial nerve
- 33 peroneal nerve

34-64 musculature (muscular system)

- 34 sternocleidomastoid muscle (sternomastoid muscle)
- 35 deltoid muscle
- 36 pectoralis major (greater pectoralis muscle, greater pectoralis)
- 37 biceps brachii (biceps of the arm)

- 38 triceps brachii (triceps of the arm)
- 39 brachioradialis
- 40 flexor carpi radialis (radial flexor of the wrist)
- 41 thenar muscle
- 42 serratus anterior
- 43 obliquus externus abdominis (external oblique)
- 44 rectus abdominis
- 45 sartorius
- 46 vastus lateralis and vastus medialis
- 47 tibialis anterior
- 48 tendo calcaneus (Achilles' tendon)
- 49 abductor hallucis (abductor of the hallux), a foot muscle
- 50 occipitalis
- 51 splenius of the neck
- 52 trapezius
- 53 infraspinatus
- 54 teres minor (lesser teres)
- 55 teres major (greater teres)
- 56 extensor carpi radialis longus (long radial extensor of the wrist)
- 57 extensor communis digitorum (common extensor of the digits)
- 58 flexor carpi ulnaris (ulnar flexor of the wrist)
- 59 latissimus dorsi
- 60 gluteus maximus
- 61 biceps femoris (biceps of the thigh)
- 62 gastrocnemius, medial and lateral heads
- 63 extensor communis digitorum (common extensor of the digits)
- 64 peroneus longus (long peroneus)

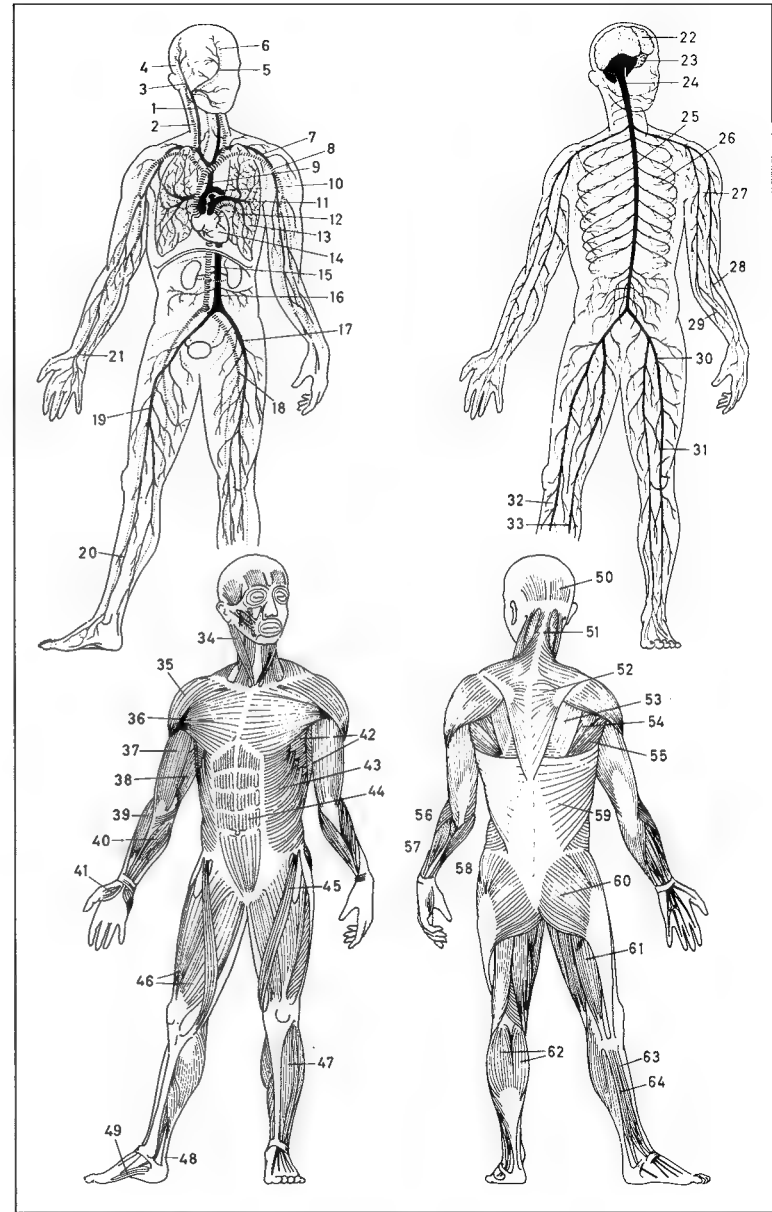

1-13 head and neck

- 1 sternocleidomastoid muscle (sternomas-toid muscle)
- 2 occipitalis
- 3 temporalis (temporal, temporal muscle)
- 4 occipito frontalis (frontalis)
- 5 orbicularis oculi
- 6 muscles of facial expression
- 7 masseter
- 8 orbicularis oris
- 9 parotid gland
- 10 lymph node (submandibular lymph gland)
- 11 submandibular gland (submaxillary gland)
- 12 muscles of the neck
- 13 Adam's apple (laryngeal prominence) [in men only]

14-37 mouth and pharynx

- 14 upper lip
- 15 gum
- 16-18 teeth (set of teeth)
- 16 incisors
- 17 canine tooth (canine)
- 18 premolar (bicuspid) and molar teeth (premolars and molars)
- 19 angle of the mouth (labial commissure)
- 20 hard palate
- 21 soft palate (velum palati, velum)
- 22 uvula
- 23 palatine tonsil (tonsil)
- 24 pharyngeal opening (pharynx)
- 25 tongue
- 26 lower lip
- 27 upper jaw (maxilla)

- 28-37 tooth
- 28 periodontal membrane (periodontium, pericementum)
- 29 cement (dental cementum, crusta pet-rosa)
- 30 enamel
- 31 dentine (dentin)
- 32 dental pulp (tooth pulp, pulp)
- 33 nerves and blood vessels
- 34 incisor
- 35 molar tooth (molar)
- 36 root (fang)
- 37 crown

38-51 eye

- 38 eyebrow (supercilium)
- 39 upper eyelid (upper palpebra)
- 40 lower eyelid (lower palpebra)
- 41 eyelash (cilium)
- 42 iris
- 43 pupil
- 44 eye muscles (ocular muscles)
- 45 eyeball
- 46 vitreous body
- 47 cornea
- 48 lens
- 49 retina
- 50 blind spot
- 51 optic nerve

- 52-63 foot
- 52 big toe (great toe, first toe, hallux, digi-tus I)
- 53 second toe (digitus II)
- 54 third toe (digitus III)
- 55 fourth toe (digitus IV)
- 56 little toe (digitus minimus, digitus V)
- 57 toenail
- 58 ball of the foot
- 59 lateral malleolus (external malleolus, outer malleolus, malleolus fibulae)
- 60 medial malleolus (internal malleolus, inner malleolus, malleolus tibulae, malleolus medialis)
- 61 instep (medial longitudinal arch, dor-sum of the foot, dorsum pedis)
- 62 sole of the foot
- 63 heel

- 64-83 hand
- 64 thumb (pollex, digitus I)
- 65 index finger (forefinger, second finger, digitus II)
- 66 middle finger (third finger, digitus medius, digitus III)
- 67 ring finger (fourth finger, digitus anu-laris, digitus IV)
- 68 little finger (fifth finger, digitus min-imus, digitus V)
- 69 radial side of the hand
- 70 ulnar side of the hand
- 71 palm of the hand (palma manus)
- 72-74 lines of the hand
- 72 life line (line of life)
- 73 head line (line of the head)
- 74 heart line (line of the heart)
- 75 ball of the thumb (thenar eminence)
- 76 wrist (carpus)
- 77 phalanx (phalange)
- 78 finger pad
- 79 fingertip
- 80 fingernail (nail)
- 81 lunule (lunula) of the nail
- 82 knuckle
- 83 back of the hand (dorsum of the hand, dorsum manus)

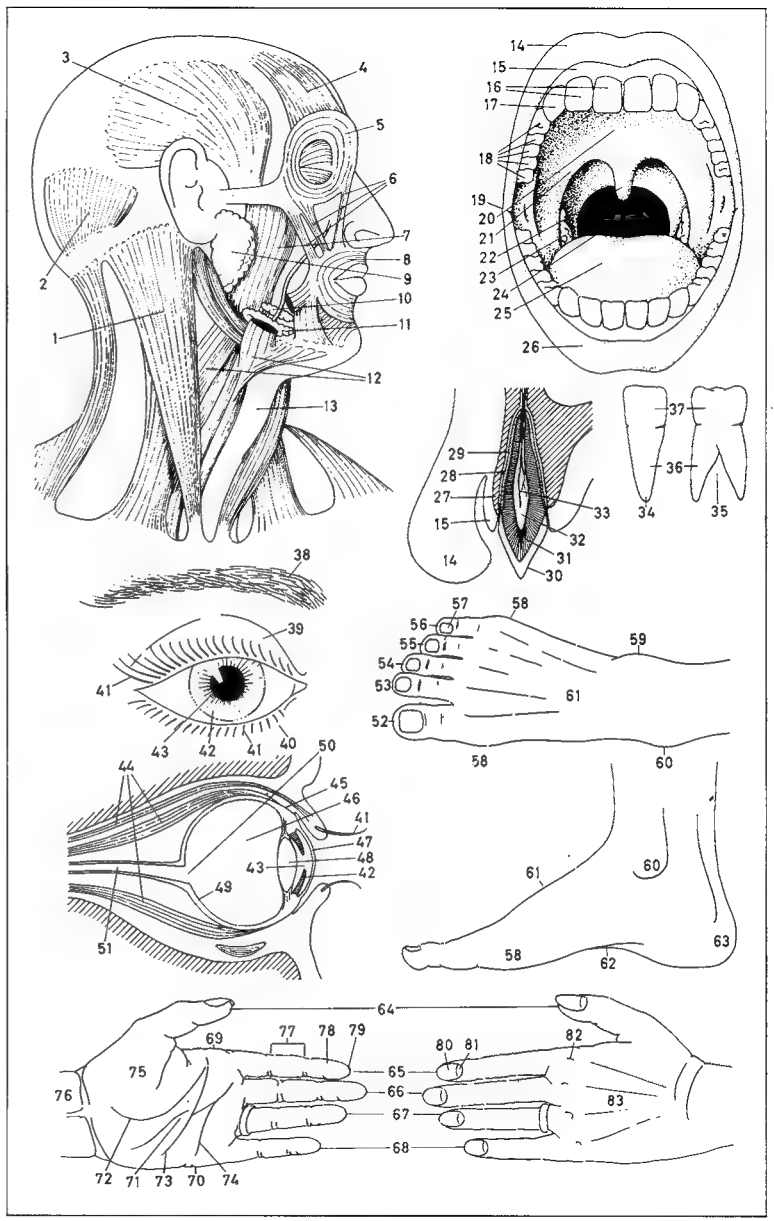

1-57 internal organs [front view]

- 1 thyroid gland
- 2, 3 larynx
- 2 hyoid bone (hyoid)
- 3 thyroid cartilage
- 4 trachea (windpipe)
- 5 bronchus
- 6, 7 lung
- 6 right lung
- 7 upper pulmonary lobe (upper lobe of the lung) [section]
- 8 heart
- 9 diaphragm
- 10 liver
- 11 gall bladder
- 12 spleen
- 13 stomach
- 14-22 **intestines** (bowel)
- 14-16 **small intestine** (intestinum tenue)
- 14 duodenum
- 15 jejunum
- 16 ileum
- 17-22 **large intestine** (intestinum crassum)
- 17 caecum (cecum)
- 18 appendix (vermiform appendix)
- 19 ascending colon
- 20 transverse colon
- 21 descending colon
- 22 rectum
- 23 oesophagus (esophagus, gullet)
- 24, 25 heart
- 24 auricle
- 25 anterior longitudinal cardiac sulcus
- 26 diaphragm
- 27 spleen
- 28 right kidney
- 29 suprarenal gland
- 30, 31 left kidney [longitudinal section]
- 30 calyx (renal calyx)
- 31 renal pelvis
- 32 ureter
- 33 bladder
- 34, 35 liver [from behind]
- 34 falciform ligament of the liver
- 35 lobe of the liver
- 36 gall bladder
- 37, 38 common bile duct
- 37 hepatic duct (common hepatic duct)
- 38 cystic duct
- 39 portal vein (hepatic portal vein)
- 40 oesophagus (esophagus, gullet)
- 41, 42 stomach
- 41 cardiac orifice
- 42 pylorus
- 43 duodenum

- 44 pancreas
- 45-57 **heart** [longitudinal section]
- 45 atrium
- 46, 47 valves of the heart
- 46 tricuspid valve (right atrioventricular valve)
- 47 bicuspid valve (mitral valve, left atrioventricular valve)
- 48 cusp
- 49 aortic valve
- 50 pulmonary valve
- 51 ventricle
- 52 ventricular septum (interventricular septum)
- 53 superior vena cava
- 54 aorta
- 55 pulmonary artery
- 56 pulmonary vein
- 57 inferior vena cava
- 58 peritoneum
- 59 sacrum
- 60 coccyx (coccygeal vertebra)
- 61 rectum
- 62 anus
- 63 anal sphincter
- 64 perineum
- 65 pubic symphysis (symphysis pubis)
- 66-77 **male sex organs** [longitudinal section]
- 66 penis
- 67 corpus cavernosum and spongiosum of the penis (erectile tissue of the penis)
- 68 urethra
- 69 glans penis
- 70 prepuce (foreskin)
- 71 serotum
- 72 right testicle (testis)
- 73 epididymis
- 74 spermatic duct (vas deferens)
- 75 Cowper's gland (bulbourethral gland)
- 76 prostate (prostate gland)
- 77 seminal vesicle
- 78 bladder
- 79-88 **female sex organs** [longitudinal section]
- 79 uterus (matrix, womb)
- 80 cavity of the uterus
- 81 fallopian tube (uterine tube, oviduct)
- 82 fimbria (fimbriated extremity)
- 83 ovary
- 84 follicle with ovum (egg)
- 85 os uteri externum
- 86 vagina
- 87 lip of the pudendum (lip of the vulva)
- 88 clitoris

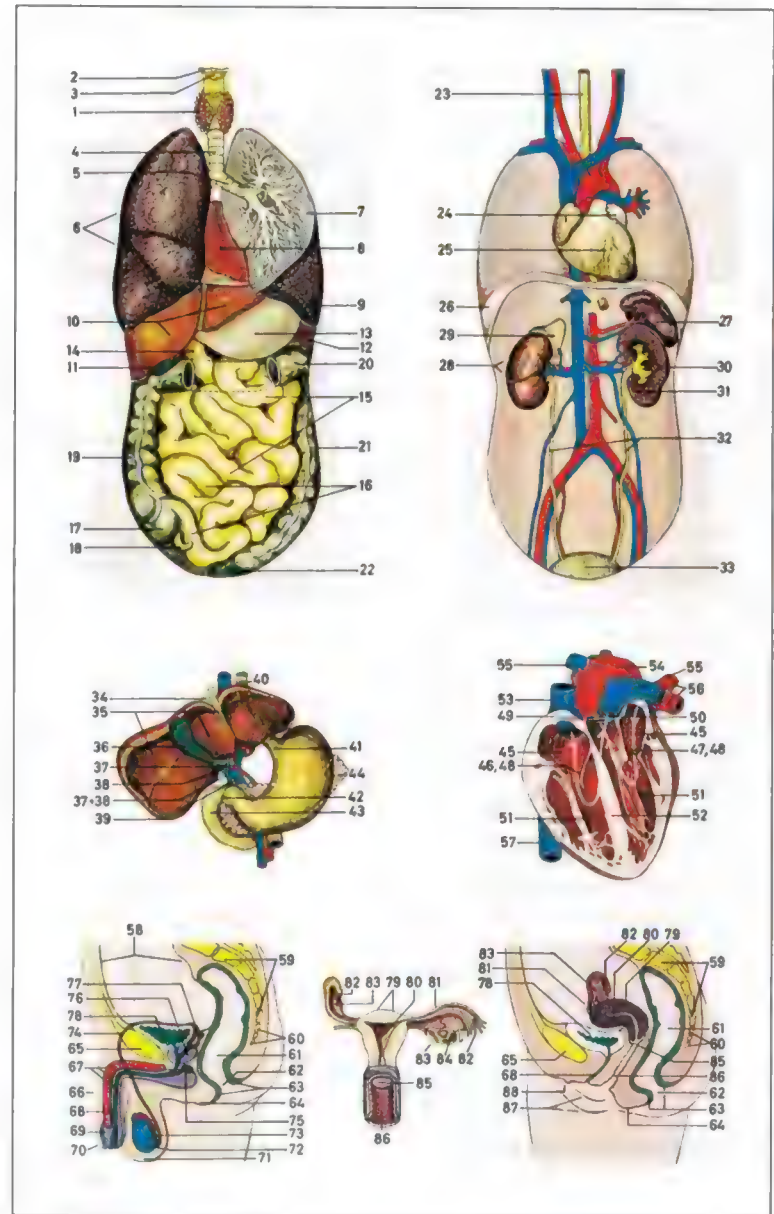

1-13 emergency bandages

- 1 arm bandage
- 2 triangular cloth used as a sling (an arm sling)
- 3 head bandage (capeline)
- 4 first aid kit
- 5 first aid dressing
- 6 sterile gauze dressing
- 7 adhesive plaster (sticking plaster)
- 8 wound
- 9 bandage
- 10 emergency splint for a broken limb (fractured limb)
- 11 fractured leg (broken leg)
- 12 splint
- 13 headrest

14-17 measures for stanching the blood flow (tying up (ligature) of a blood vessel)

- 14 pressure points of the arteries
- 15 emergency tourniquet on the thigh
- 16 walking stick used as a screw
- 17 compression bandage

18-23 rescue and transport of an injured person

- 18 Rautek grip (for rescue of a car accident victim)
- 19 helper
- 20 injured person (casualty)
- 21 chair grip
- 22 carrying grip
- 23 emergency stretcher of sticks and a jacket

24-27 positioning of an unconscious person and artificial respiration (resuscitation)

- 24 coma position
- 25 unconscious person
- 26 mouth-to-mouth resuscitation (variation: mouth-to-nose resuscitation)
- 27 resuscitator (respiratory apparatus, resuscitation apparatus), a respirator (artificial breathing device)

28-33 methods of rescue in ice accidents

- 28 person who has fallen through the ice
- 29 rescuer
- 30 rope
- 31 table (or similar device)
- 32 ladder
- 33 self-rescue
- 34-38 rescue of a drowning person
- 34 method of release (release grip, release) to free rescuer from the clutch of a drowning person
- 35 drowning person
- 36 lifesaver
- 37, 38 towing (tows)
- 37 double shoulder tow
- 38 head tow

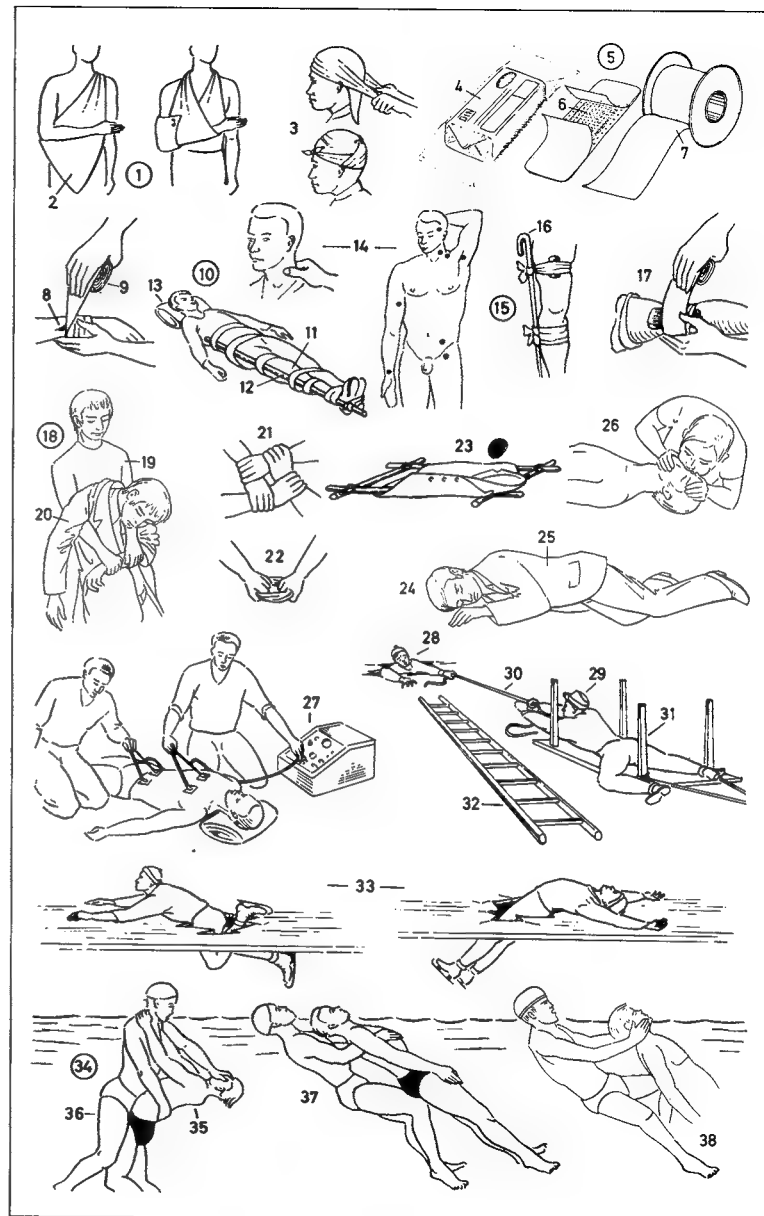

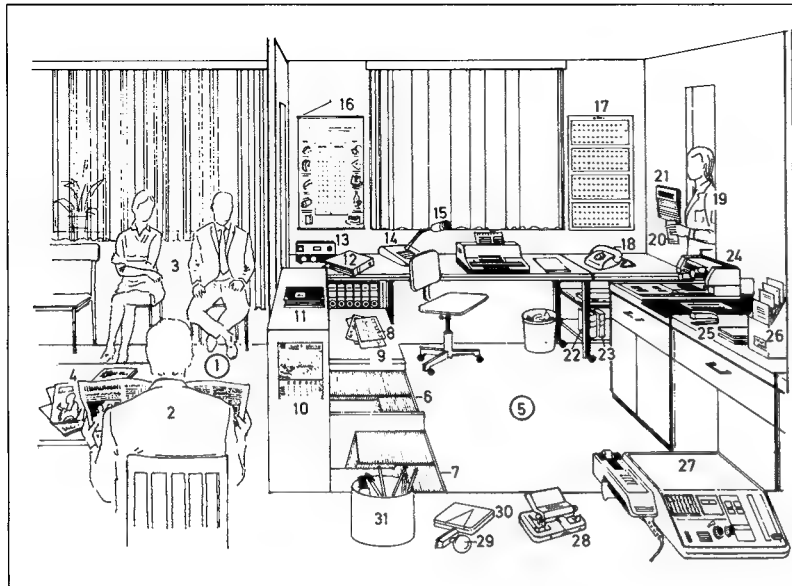

1-74 general practice (*Am. physician's office*)

- 1 waiting room
- 2 patient
- 3 patients with appointments (for a routine check-up or renewal of prescription)
- 4 magazines [for waiting patients]
- 5 reception
- 6 patients file
- 7 eliminated index cards
- 8 medical record (medical card)
- 9 health insurance certificate
- 10 advertising calendar (publicity calendar)
- 11 appointments book
- 12 correspondence file
- 13 automatic telephone answering and recording set (telephone answering device)
- 14 radiophone
- 15 microphone
- 16 illustrated chart

- 17 wall calendar
- 18 telephone
- 19 [doctor's] assistant
- 20 prescription
- 21 telephone index
- 22 medical dictionary
- 23 pharmacopoeia (list of registered medicines)
- 24 franking machine (*Am. postage meter*)
- 25 stapler
- 26 diabetics file
- 27 dictating machine
- 28 paper punch
- 29 doctor's stamp
- 30 ink pad
- 31 pencil holder
- 32-74 surgery
- 32 chart of eyegrounds
- 33 doctor's bag (doctor's case)
- 34 intercom
- 35 medicine cupboard
- 36 swab dispenser

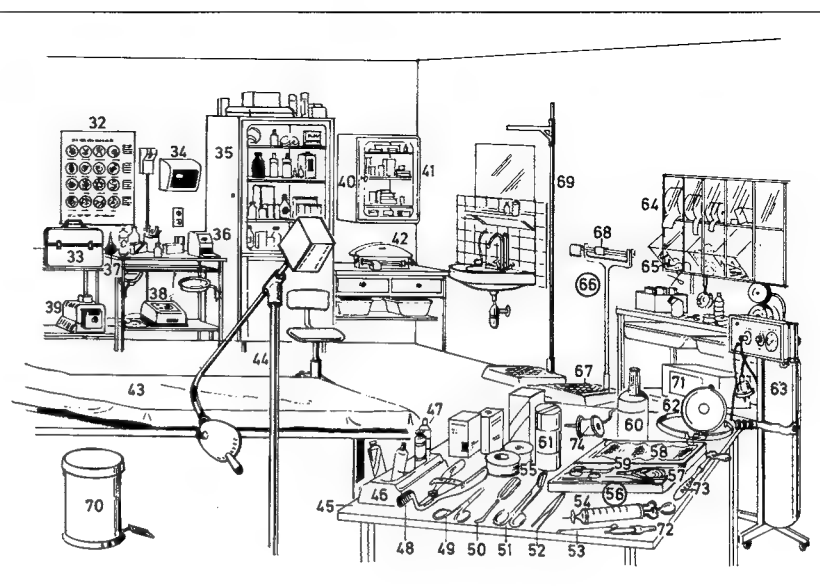

- 37 inflator (Poltizer bag)
- 38 electrotome
- 39 steam sterilizer
- 40 cabinet
- 41 medicine samples (from the pharmaceutical industry)
- 42 baby scales
- 43 examination couch
- 44 directional lamp
- 45 instrument table
- 46 tube holder
- 47 tube of ointment
- 48-50 instruments for minor surgery
- 48 mouth gag
- 49 Kocher's forceps
- 50 scoop (curette)
- 51 angled scissors
- 52 forceps
- 53 olive-pointed (bulb-headed) probe
- 54 syringe for irrigations of the ear or bladder
- 55 adhesive plaster (sticking plaster)
- 56 surgical suture material

- 57 curved surgical needle
- 58 sterile gauze
- 59 needle holder
- 60 spray for disinfecting the skin
- 61 thread container
- 62 ophthalmoscope
- 63 freezer for cryosurgery
- 64 dispenser for plasters and small pieces of equipment
- 65 disposable hypodermic needles and syringes
- 66 scales, sliding-weight scales
- 67 weighing platform
- 68 sliding weight (jockey)
- 69 height gauge (*Am. gage*)
- 70 waste bin (*Am. trash bin*)
- 71 hot-air sterilizer
- 72 pipette
- 73 percussor
- 74 aural speculum (auriscope, aural syringe)

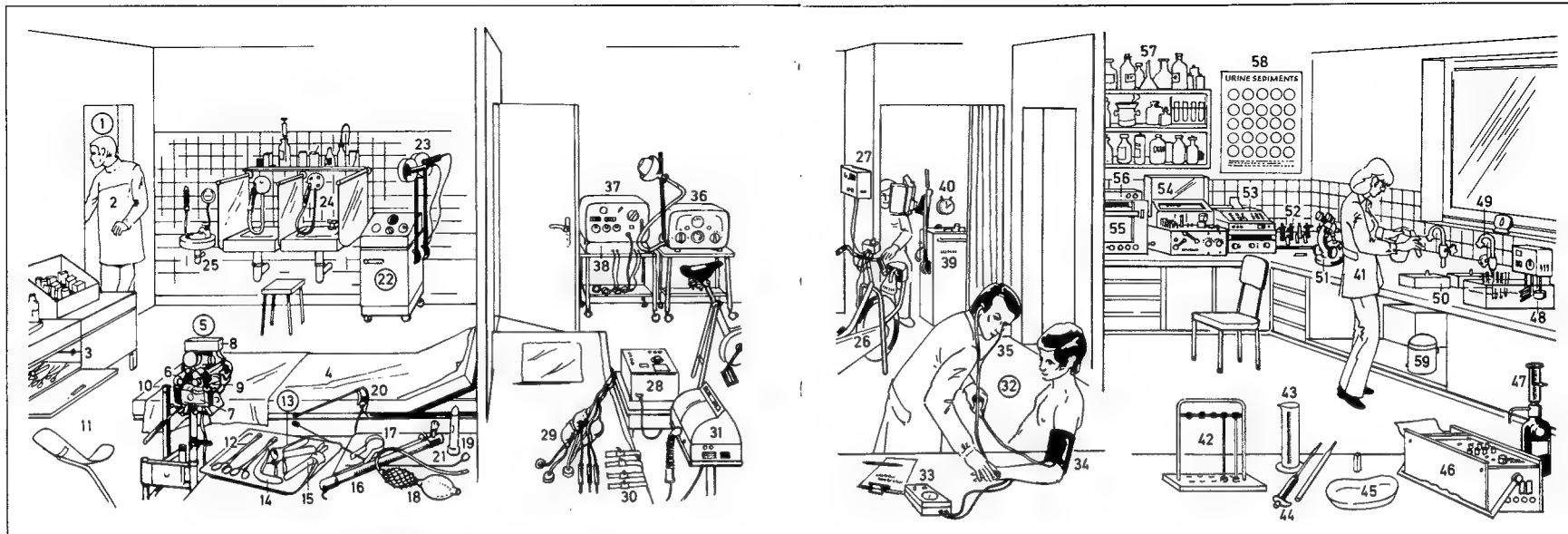

- | | | | |
|---|--|--|--|
| 1 consulting room | 19 proctoscope (rectal speculum) | 37 faradization unit (for applying low-frequency currents with different pulse shapes) | 51 binocular research microscope |
| 2 general practitioner | 20 urethroscope | 38 automatic tuner | 52 pipette stand for photometry |
| 3-21 instruments for gynaecological and proctological examinations | 21 guide for inserting the proctoscope | 39 short-wave therapy apparatus | 53 computer and analyser for photometry |
| 3 warming the instruments up to body temperature | 22 diathermy unit (short-wave therapy apparatus) | 40 timer | 54 photometer |
| 4 examination couch | 23 radiator | 41-59 laboratory | 55 potentiometric recorder |
| 5 colposcope | 24 inhaling apparatus (inhalator) | 41 medical laboratory technician | 56 transforming section |
| 6 binocular eyepiece | 25 basin [for sputum] | 42 capillary tube stand for blood sedimentation | 57 laboratory apparatus (laboratory equipment) |
| 7 miniature camera | 26-31 ergometry | 43 measuring cylinder | 58 urine sediment chart |
| 8 cold light source | 26 bicycle ergometer | 44 automatic pipette | 59 centrifuge |
| 9 cable release | 27 monitor (for visual display of the ECG and of pulse and respiratory rates when performing work) | 45 kidney dish | |
| 10 bracket for the leg support | 28 ECG (electrocardiograph) | 46 portable ECG machine for emergency use | |
| 11 leg support (leg holder) | 29 suction electrodes | 47 automatic pipetting device | |
| 12 holding forceps (sponge holder) | 30 strap-on electrodes for the limbs | 48 constant temperature water bath | |
| 13 vaginal speculum | 31 spirometer (for measuring respiratory functions) | 49 tap with water jet pump | |
| 14 lower blade of the vaginal speculum | 32 measuring blood pressure | 50 staining dish (for staining blood smears, sediments, and other smears) | |
| 15 platinum loop (for smears) | 33 sphygmomanometer | | |
| 16 rectoscope | 34 inflatable cuff | | |
| 17 biopsy forceps used with the rectoscope (proctoscope) | 35 stethoscope | | |
| 18 insufflator for proctoscopy (rectoscopy) | 36 microwave treatment unit | | |

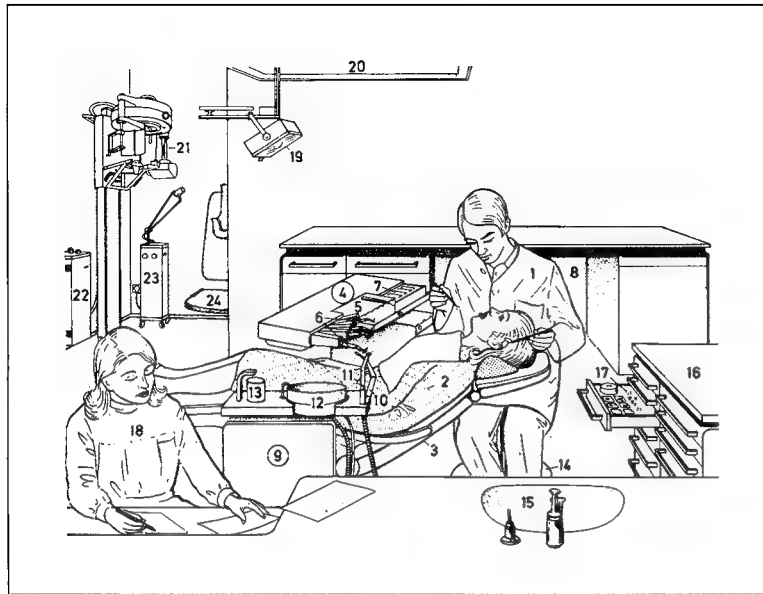

- | | |
|---|---|
| 1 dentist (dental surgeon) | 21 X-ray apparatus for panoramic pictures |
| 2 patient | 22 X-ray generator |
| 3 dentist's chair | 23 microwave treatment unit, a radiation unit |
| 4 dental instruments | 24 seat |
| 5 instrument tray | 25 denture (set of false teeth) |
| 6 drills with different handpieces | 26 bridge (dental bridge) |
| 7 medicine case | 27 prepared stump of the tooth |
| 8 storage unit (for dental instruments) | 28 crown (<i>kinds</i> : gold crown, jacket crown) |
| 9 assistant's unit | 29 porcelain tooth (porcelain pontic) |
| 10 multi-purpose syringe (for cold and warm water, spray, or air) | 30 filling |
| 11 suction apparatus | 31 post crown |
| 12 basin | 32 facing |
| 13 water glass, filled automatically | 33 diaphragm |
| 14 stool | 34 post |
| 15 washbasin | 35 carborundum disc (disk) |
| 16 instrument cabinet | 36 grinding wheel |
| 17 drawer for drills | 37 burs |
| 18 dentist's assistant | 38 flame-shaped finishing bur |
| 19 dentist's lamp | 39 fissure burs |
| 20 ceiling light | |

- | |
|--|
| 40 diamond point |
| 41 mouth mirror |
| 42 mouth lamp |
| 43 cautery |
| 44 platinum-iridium electrode |
| 45 tooth scalers |
| 46 probe |
| 47 extraction forceps |
| 48 tooth-root elevator |
| 49 bone chisel |
| 50 spatula |
| 51 mixer for filling material |
| 52 synchronous timer |
| 53 hypodermic syringe for injection of local anaesthetic |
| 54 hypodermic needle |
| 55 matrix holder |
| 56 impression tray |
| 57 spirit lamp |

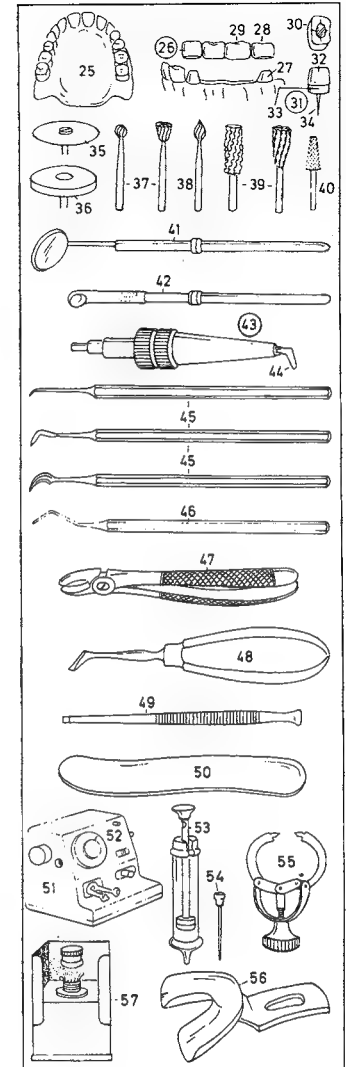

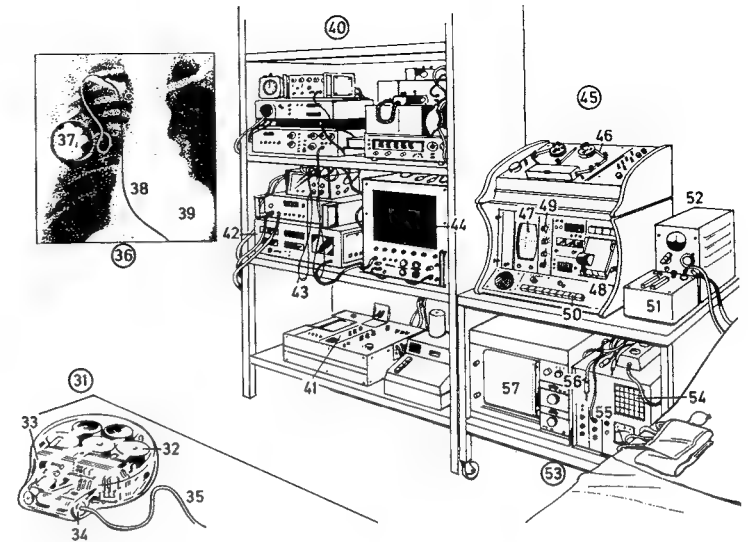
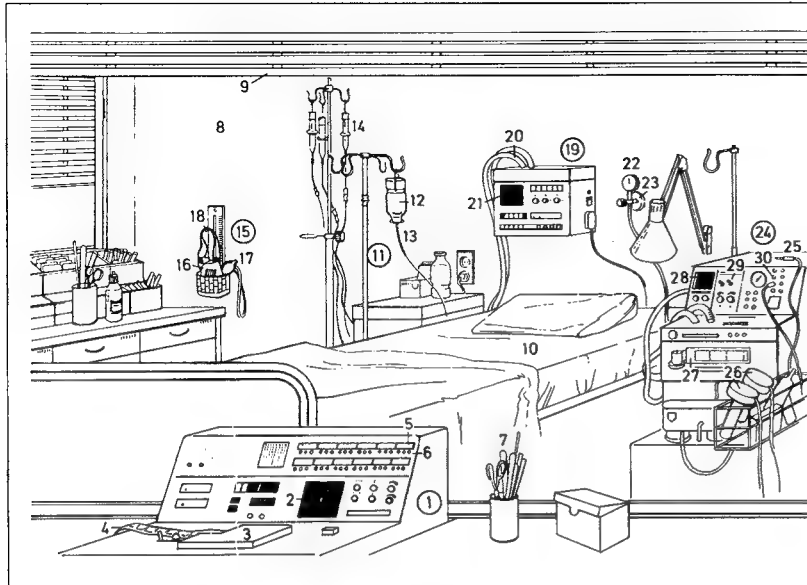
**1-30 intensive care unit****1-9 control room**

- 1 central control unit for monitoring heart rhythm (cardiac rhythm) and blood pressure
- 2 electrocardiogram monitor (ECG monitor)
- 3 recorder
- 4 recording paper
- 5 patient's card
- 6 indicator lights (with call buttons for each patient)
- 7 spatula
- 8 window (observation window, glass partition)
- 9 blind
- 10 bed (hospital bed)
- 11 stand for infusion apparatus
- 12 infusion bottle
- 13 tube for intravenous drips
- 14 infusion device for water-soluble medicaments
- 15 sphygmomanometer

- 16 cuff
- 17 inflating bulb
- 18 mercury manometer
- 19 bed monitor
- 20 connecting lead to the central control unit
- 21 electrocardiogram monitor (ECG monitor)
- 22 manometer for the oxygen supply
- 23 wall connection for oxygen treatment
- 24 mobile monitoring unit
- 25 electrode lead to the short-term pacemaker
- 26 electrodes for shock treatment
- 27 ECG recording unit
- 28 electrocardiogram monitor (ECG monitor)
- 29 control switches and knobs (controls) for adjusting the monitor
- 30 control buttons for the pacemaker unit
- 31 **pacemaker** (cardiac pacemaker)

- 32 mercury battery
- 33 programmed impulse generator
- 34 electrode exit point
- 35 electrode
- 36 implantation of the pacemaker
- 37 internal cardiac pacemaker (internal pacemaker, pacemaker)
- 38 electrode inserted through the vein
- 39 cardiac silhouette on the X-ray
- 40 **pacemaker control unit**
- 41 electrocardiograph (ECG recorder)
- 42 automatic impulse meter
- 43 ECG lead to the patient
- 44 monitor unit for visual monitoring of the pacemaker impulses
- 45 long-term ECG analyser
- 46 magnetic tape for recording the ECG impulses during analysis
- 47 ECG monitor
- 48 automatic analysis on paper of the ECG rhythm

- 49 control knob for the ECG amplitude
- 50 program selector switches for the ECG analysis
- 51 charger for the pacemaker batteries
- 52 battery tester
- 53 pressure gauge (*Am. gage*) for the right cardiac catheter
- 54 trace monitor
- 55 pressure indicator
- 56 connecting lead to the paper recorder
- 57 paper recorder for pressure traces

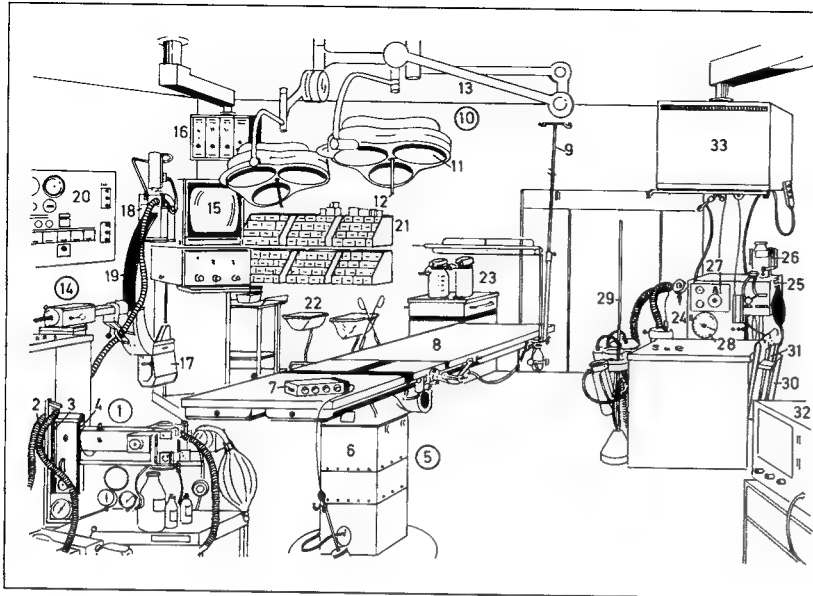
**1-54 surgical unit****1-33 operating theatre** (*Am. theater*)

- 1 anaesthesia and breathing apparatus (respiratory machine)
- 2 inhalers (inhaling tubes)
- 3 flowmeter for nitrous oxide
- 4 oxygen flow meter
- 5 pedestal operating table
- 6 table pedestal
- 7 control device (control unit)
- 8 adjustable top of the operating table
- 9 stand for intravenous drips
- 10 swivel-mounted shadow-free operating lamp
- 11 individual lamp
- 12 handle
- 13 swivel arm
- 14 mobile fluoroscope
- 15 monitor of the image converter
- 16 monitor [back]
- 17 tube
- 18 image converter
- 19 C-shaped frame
- 20 control panel for the air-conditioning
- 21 surgical suture material
- 22 mobile waste tray
- 23 containers for unsterile (unsterilized) pads
- 24 anaesthesia and respiratory apparatus
- 25 respirator
- 26 fluothane container (halothane container)
- 27 ventilation control knob
- 28 indicator with pointer for respiratory volume
- 29 stand with inhalers (inhaling tubes) and pressure gauges (*Am. gages*)
- 30 catheter holder
- 31 catheter in sterile packing
- 32 sphygmograph
- 33 monitor

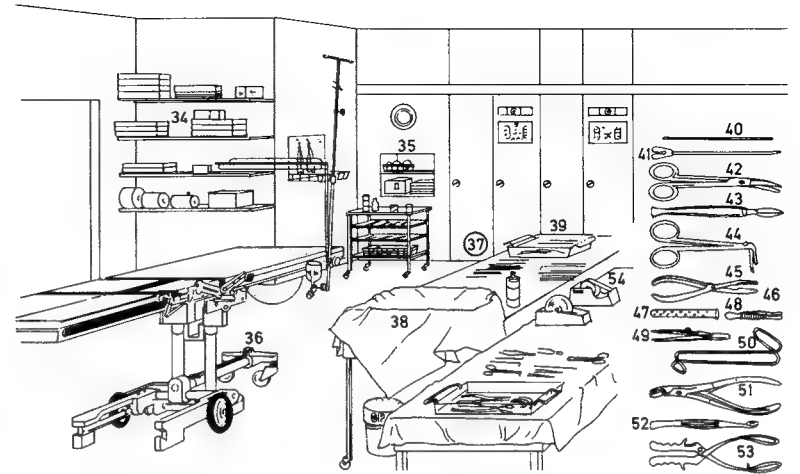
**34-54 preparation and sterilization room**

- 34 dressing material
- 35 small sterilizer
- 36 carriage of the operating table
- 37 mobile instrument table
- 38 sterile cloth
- 39 instrument tray
- 40-53 surgical instruments**
- 40 olive-pointed (bulb-headed) probe
- 41 hollow probe
- 42 curved scissors
- 43 scalpel (surgical knife)
- 44 ligature-holding forceps
- 45 sequestrum forceps
- 46 jaw
- 47 drainage tube
- 48 surgeon's tourniquet
- 49 artery forceps
- 50 blunt hook
- 51 bone nippers (bone-cutting forceps)

- 52 scoop (curette) for erosion (curet-tage)
- 53 obstetrical forceps
- 54 roll of plaster

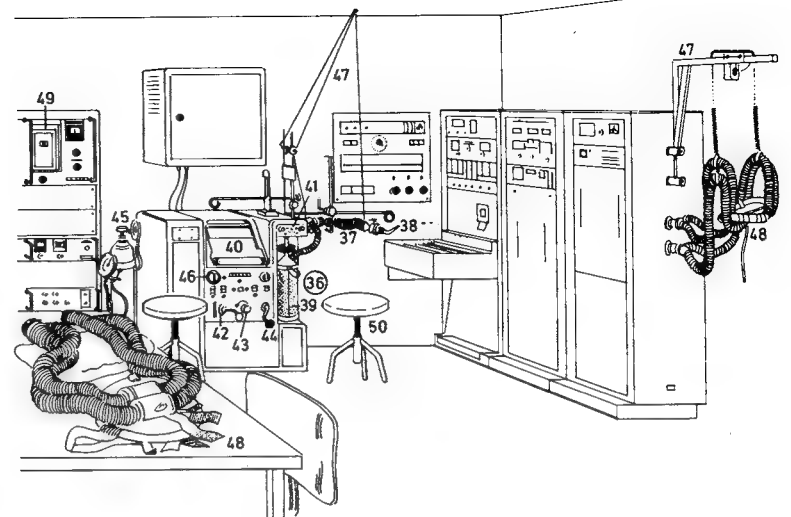
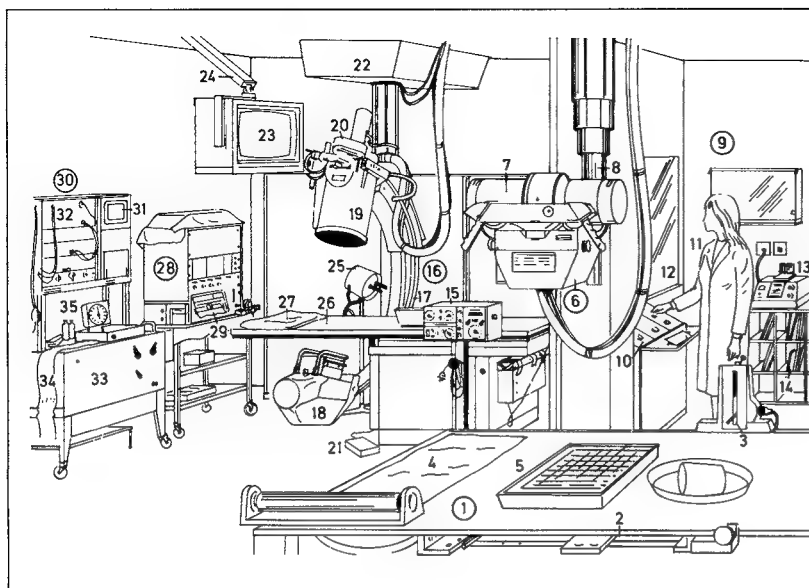
**1-35 X-ray unit**

- 1 X-ray examination table
- 2 support for X-ray cassettes
- 3 height adjustment of the central beam for lateral views
- 4 compress for pyelography and cholecystography
- 5 instrument basin
- 6 X-ray apparatus for pyelograms
- 7 X-ray tube
- 8 telescopic X-ray support
- 9 central X-ray control unit
- 10 control panel (control desk)
- 11 radiographer (X-ray technician)
- 12 window to the angiography room
- 13 oxymeter
- 14 pyelogram cassettes
- 15 contrast medium injector
- 16 X-ray image intensifier
- 17 C-shaped frame
- 18 X-ray head with X-ray tube
- 19 image converter with converter tube

- 20 film camera
- 21 foot switch
- 22 mobile mounting
- 23 monitor
- 24 swivel-mounted monitor support
- 25 operating lamp
- 26 angiographic examination table
- 27 pillow
- 28 eight-channel recorder
- 29 recording paper
- 30 catheter gauge (*Am. gage*) unit for catheterization of the heart
- 31 six-channel monitor for pressure graphs and ECG
- 32 slide-in units of the pressure transducer
- 33 paper recorder unit with developer for photographic recording
- 34 recording paper
- 35 timer
- 36-50 **spirometry**
- 36 spirometer for pulmonary function tests

- 37 breathing tube
- 38 mouthpiece
- 39 soda-lime absorber
- 40 recording paper
- 41 control knobs for gas supply
- 42 O₂ stabilizer
- 43 throttle valve
- 44 absorber attachment
- 45 oxygen cylinder
- 46 water supply
- 47 tube support
- 48 mask
- 49 CO₂ consumption meter
- 50 stool for the patient

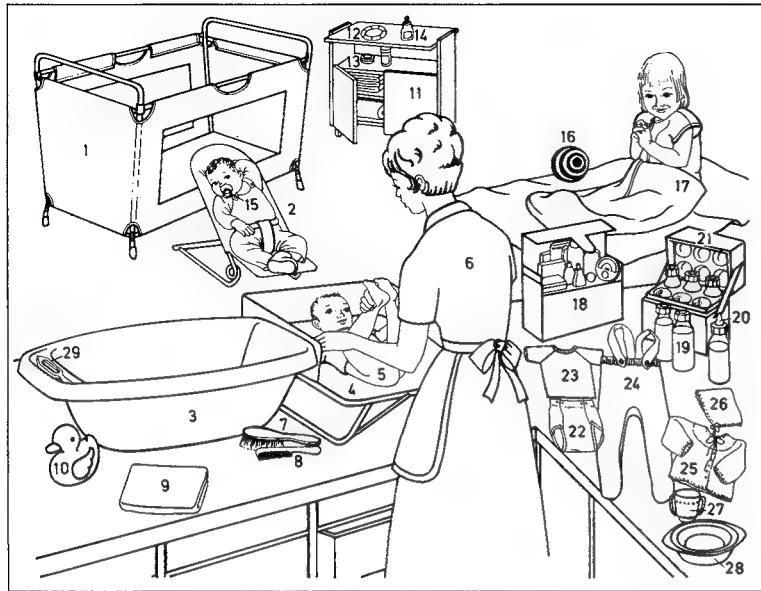

- | | |
|------------------------|---|
| 1 collapsible cot | 22 rubber baby pants for disposable nappies (<i>Am.</i> diapers) |
| 2 bouncing cradle | 23 vest |
| 3 baby bath | 24 leggings |
| 4 changing top | 25 baby's jacket |
| 5 baby (new-born baby) | 26 hood |
| 6 mother | 27 baby's cup |
| 7 hairbrush | 28 baby's plate, a stay-warm plate |
| 8 comb | 29 thermometer |
| 9 hand towel | |
| 10 toy duck | |
| 11 changing unit | |
| 12 teething ring | |
| 13 cream jar | |
| 14 box of baby powder | |
| 15 dummy | |
| 16 ball | |
| 17 sleeping bag | |
| 18 layette box | |
| 19 feeding bottle | |
| 20 teat | |
| 21 bottle warmer | |

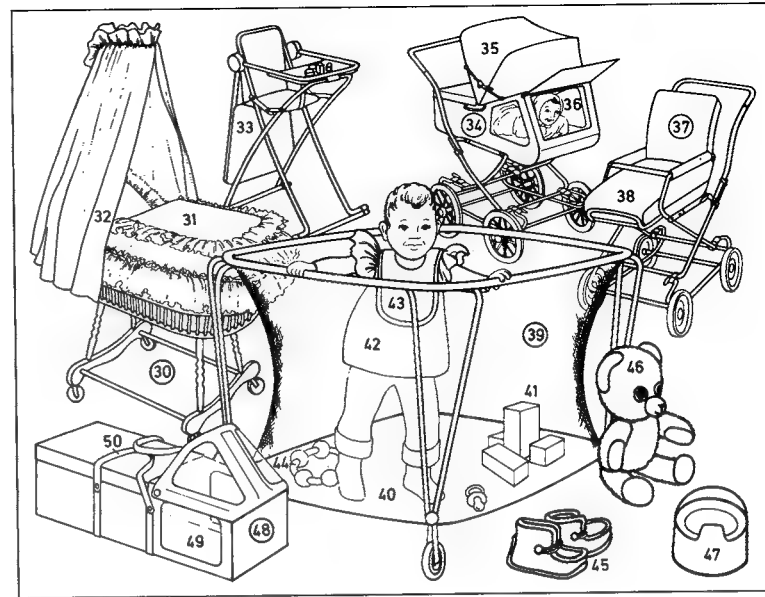

- | |
|--|
| 30 bassinet, a wicker pram |
| 31 set of bassinet covers |
| 32 canopy |
| 33 baby's high chair, a folding chair |
| 34 pram (baby-carriage) [with windows] |
| 35 folding hood |
| 36 window |
| 37 pushchair (<i>Am.</i> stroller) |
| 38 foot-muff (<i>Am.</i> foot-bag) |
| 39 play pen |
| 40 floor of the play pen |
| 41 building blocks (building bricks) |
| 42 small child |
| 43 bib |
| 44 rattle (baby's rattle) |
| 45 booties |
| 46 teddy bear |
| 47 potty (baby's pot) |
| 48 carrycot |
| 49 window |
| 50 handles |

1-12 baby clothes

- 1 pram suit
 - 2 hood
 - 3 pram jacket (matinée coat)
 - 4 pompon (bobble)
 - 5 bootees
 - 6 sleeveless vest
 - 7 envelope-neck vest
 - 8 wrapover vest
 - 9 baby's jacket
 - 10 rubber baby pants
 - 11 playsuit
 - 12 two-piece suit
- 13-30 infants' wear**
- 13 child's sundress, a pinafore dress
 - 14 frilled shoulder strap
 - 15 Shirred top
 - 16 sun hat
 - 17 one-piece jersey suit
 - 18 front zip (*Am.* zipper)
 - 19 catsuit (playsuit)
 - 20 motif (appliqué)
 - 21 romper
 - 22 playsuit (romper suit)
 - 23 overall (sleeper and strampler)
 - 24 dressing gown (bath robe)
 - 25 children's shorts
 - 26 braces (*Am.* suspenders)
 - 27 children's T-shirt
 - 28 jersey dress (knitted dress)
 - 29 embroidery
 - 30 children's ankle socks
- 31-47 school children's wear**
- 31 raincoat
 - 32 leather shorts (lederhosen)
 - 33 staghorn button
 - 34 braces (*Am.* suspenders)
 - 35 flap
 - 36 girl's dirndl
 - 37 cross lacing
 - 38 snow suit (quilted suit)
 - 39 quilt stitching (quilting)
 - 40 dungarees (bib and brace)
 - 41 bib skirt (bib top pinafore)
 - 42 tights
 - 43 sweater (jumper)

- 44 pile jacket
 - 45 leggings
 - 46 girl's skirt
 - 47 child's jumper
- 48-68 teenagers' clothes**
- 48 girl's overblouse (overtop)
 - 49 slacks
 - 50 girl's skirt suit
 - 51 jacket
 - 52 skirt
 - 53 knee-length socks
 - 54 girl's coat
 - 55 tie belt
 - 56 girl's bag
 - 57 woollen (*Am.* woolen) hat
 - 58 girl's blouse
 - 59 culottes
 - 60 boy's trousers
 - 61 boy's shirt
 - 62 anorak
 - 63 inset pockets
 - 64 hood drawstring (drawstring)
 - 65 knitted welt
 - 66 parka coat (parka)
 - 67 drawstring (parka cord)
 - 68 patch pockets



- | | |
|--|--|
| 1 mink jacket | 45 two-piece combination (shirt top and long skirt) |
| 2 cowl neck jumper | 46 tie (bow) |
| 3 cowl collar | 47 decorative facing |
| 4 knitted overtop | 48 cuff slit |
| 5 turndown collar | 49 side slit |
| 6 turn-up (turnover) sleeve | 50 tabard |
| 7 polo neck jumper | 51 inverted pleat skirt |
| 8 pinafore dress | 52 godet |
| 9 blouse (with revers collar) | 53 evening gown |
| 10 shirt-waister dress, a button-through dress | 54 pleated bell sleeve |
| 11 belt | 55 party blouse |
| 12 winter dress | 56 party skirt |
| 13 piping | 57 trouser suit (slack suit) |
| 14 cuff | 58 suede jacket |
| 15 long sleeve | 59 fur trimming |
| 16 quilted waistcoat | 60 fur coat (<i>kinds: Persian lamb, broadtail, mink, sable</i>) |
| 17 quilt stitching (quilting) | 61 winter coat (cloth coat) |
| 18 leather trimming | 62 fur cuff (fur-trimmed cuff) |
| 19 winter slacks | 63 fur collar (fur-trimmed collar) |
| 20 striped polo jumper | 64 loden coat |
| 21 boiler suit (dungarees, bib and brace) | 65 cape |
| 22 patch pocket | 66 toggle fastenings |
| 23 front pocket | 67 loden skirt |
| 24 bib | 68 poncho-style coat |
| 25 wrapover dress (wrap-around dress) | 69 hood |
| 26 shirt | |
| 27 peasant-style dress | |
| 28 floral braid | |
| 29 tunic (tunic top) | |
| 30 ribbed cuff | |
| 31 quilted design | |
| 32 pleated skirt | |
| 33 two-piece knitted dress | |
| 34 boat neck, a neckline | |
| 35 turn-up | |
| 36 kimono sleeve | |
| 37 knitted design | |
| 38 lumber-jacket | |
| 39 cable pattern | |
| 40 shirt-blouse | |
| 41 loop fastening | |
| 42 embroidery | |
| 43 stand-up collar | |
| 44 cossack trousers | |



- | | |
|--------------------------------------|--------------------------------|
| 1 skirt suit | 48 culotte |
| 2 jacket | 49 twin set |
| 3 skirt | 50 cardigan |
| 4 inset pocket | 51 sweater |
| 5 decorative stitching | 52 summer (lightweight) slacks |
| 6 dress and jacket combination | 53 jumpsuit |
| 7 piping | 54 turn-up |
| 8 pinafore dress | 55 zip (<i>Am.</i> zipper) |
| 9 summer dress | 56 patch pocket |
| 10 belt | 57 scarf (neckerchief) |
| 11 two-piece dress | 58 denim suit |
| 12 belt buckle | 59 denim waistcoat |
| 13 wrapover (wrap-around) skirt | 60 jeans (denims) |
| 14 pencil silhouette | 61 overblouse |
| 15 shoulder buttons | 62 turned-up sleeve |
| 16 batwing sleeve | 63 stretch belt |
| 17 overdress | 64 halter top |
| 18 kimono yoke | 65 knitted overtop |
| 19 tie belt | 66 drawstring waist |
| 20 summer coat | 67 short-sleeved jumper |
| 21 detachable hood | 68 V-neck (vee-neck) |
| 22 summer blouse | 69 turndown collar |
| 23 lapel | 70 knitted welt |
| 24 skirt | 71 shawl |
| 25 front pleat | |
| 26 dirndl (dirndl dress) | |
| 27 puffed sleeve | |
| 28 dirndl necklace | |
| 29 dirndl blouse | |
| 30 bodice | |
| 31 dirndl apron | |
| 32 lace trimming (lace), cotton lace | |
| 33 frilled apron | |
| 34 frill | |
| 35 smock overall | |
| 36 house frock (house dress) | |
| 37 poplin jacket | |
| 38 T-shirt | |
| 39 ladies' shorts | |
| 40 trouser turn-up | |
| 41 waistband | |
| 42 bomber jacket | |
| 43 stretch welt | |
| 44 Bermuda shorts | |
| 45 saddle stitching | |
| 46 frill collar | |
| 47 knot | |

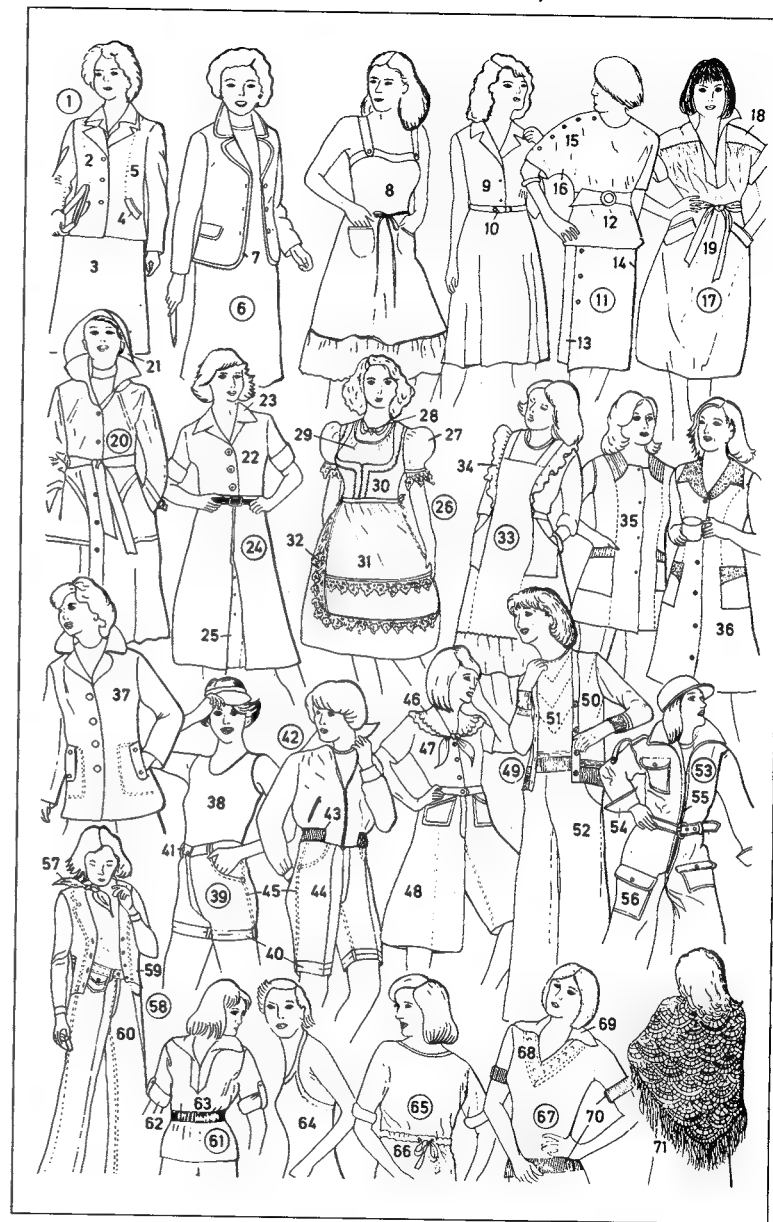

- 1-15 ladies' underwear (ladies' underclothes, lingerie)
- 1 brassière (bra)
- 2 pantie-girdle
- 3 pantie-corselette
- 4 longline brassière (longline bra)
- 5 stretch girdle
- 6 suspender
- 7 vest
- 8 pantie briefs
- 9 ladies' knee-high stocking
- 10 long-legged (long leg) panties
- 11 long pants
- 12 tights (pantie-hose)
- 13 slip
- 14 waist slip
- 15 bikini briefs
- 16-21 ladies' nightwear
- 16 nightdress (nightgown, nightie)
- 17 pyjamas (*Am.* pajamas)
- 18 pyjama top
- 19 pyjama trousers
- 20 housecoat
- 21 vest and shorts set [for leisure wear and as nightwear]
- 22-29 men's underwear (men's underclothes)
- 22 string vest
- 23 string briefs
- 24 front panel
- 25 sleeveless vest
- 26 briefs
- 27 trunks
- 28 short-sleeved vest
- 29 long johns
- 30 braces (*Am.* suspenders)
- 31 braces clip
- 32-34 men's socks
- 32 knee-length sock
- 33 elasticated top
- 34 long sock
- 35-37 men's nightwear
- 35 dressing gown
- 36 pyjamas (*Am.* pajamas)
- 37 nightshirt
- 38-47 men's shirts
- 38 casual shirt

- 39 belt
- 40 cravat
- 41 tie
- 42 knot
- 43 dress shirt
- 44 frill (frill front)
- 45 cuff
- 46 cuff link
- 47 bow-tie



1-67 men's fashion

- 1 single-breasted suit, a men's suit
- 2 jacket
- 3 suit trousers
- 4 waistcoat (vest)
- 5 lapel
- 6 trouser leg with crease
- 7 dinner dress, an evening suit
- 8 silk lapel
- 9 breast pocket
- 10 dress handkerchief
- 11 bow-tie
- 12 side pocket
- 13 tailcoat (tails), evening dress
- 14 coat-tail
- 15 white waistcoat (vest)
- 16 white bow-tie
- 17 casual suit
- 18 pocket flap
- 19 front yoke
- 20 denim suit
- 21 denim jacket
- 22 jeans (denims)
- 23 waistband
- 24 beach suit
- 25 shorts
- 26 short-sleeved jacket
- 27 tracksuit
- 28 tracksuit top with zip
- 29 tracksuit bottoms
- 30 cardigan
- 31 knitted collar
- 32 men's short-sleeved pullover
(men's short-sleeved sweater)
- 33 short-sleeved shirt
- 34 shirt button
- 35 turn-up
- 36 knitted shirt
- 37 casual shirt
- 38 patch pocket
- 39 casual jacket
- 40 knee-breeches
- 41 knee strap
- 42 knee-length sock
- 43 leather jacket
- 44 bib and brace overalls

- 45 adjustable braces (*Am. sus-
penders*)
- 46 front pocket
- 47 trouser pocket
- 48 fly
- 49 rule pocket
- 50 check shirt
- 51 men's pullover
- 52 heavy pullover
- 53 knitted waistcoat (vest)
- 54 blazer
- 55 jacket button
- 56 overall
- 57 trenchcoat
- 58 coat collar
- 59 coat belt
- 60 poplin coat
- 61 coat pocket
- 62 fly front
- 63 car coat
- 64 coat button
- 65 scarf
- 66 cloth coat
- 67 glove



1-25 men's beards and hairstyles

- 33 curled hair
- 34 shingle (shingled hair, bobbed hair)
- 35 pageboy style
- 36 fringe (Am. bangs)
- 37 earphones
- 38 earphone (coiled plait)

- (haircuts)
- 1 long hair worn loose
- 2 allonge perwig (full-bottomed wig), a wig; shorter and smoother: bob wig, toupet
- 3 curls
- 4 bag wig (purse wig)
- 5 pigtail
- 6 queue (pigtail)
- 7 bow (ribbon)
- 8 handlebars (handlebar moustache, Am. mustache)
- 9 centre (Am. center) parting
- 10 goatee (goatee beard), chintuft
- 11 closely-cropped head of hair (crew cut)
- 12 whiskers
- 13 Vandyke beard (stiletto beard, bodkin beard), with waxed moustache (Am. mustache)
- 14 side parting
- 15 full beard (circular beard, round beard)
- 16 tile beard
- 17 shadow
- 18 head of curly hair
- 19 military moustache (Am. moustache) (English-style moustache)
- 20 partly bald head
- 21 bald patch
- 22 bald head
- 23 stubble beard (stubble, short beard bristles)
- 24 side-whiskers (sideboards, sideburns)
- 25 clean shave
- 26 Afro look (for men and women)
- 27-38 ladies' hairstyles (coiffures, women's and girls' hairstyles)
- 27 ponytail
- 28 swept-back hair (swept-up hair, pinned-up hair)
- 29 bun (chignon)
- 30 plaits (bunches)
- 31 chaplet hairstyle (Gretchen style)
- 32 chaplet (coiled plaits)

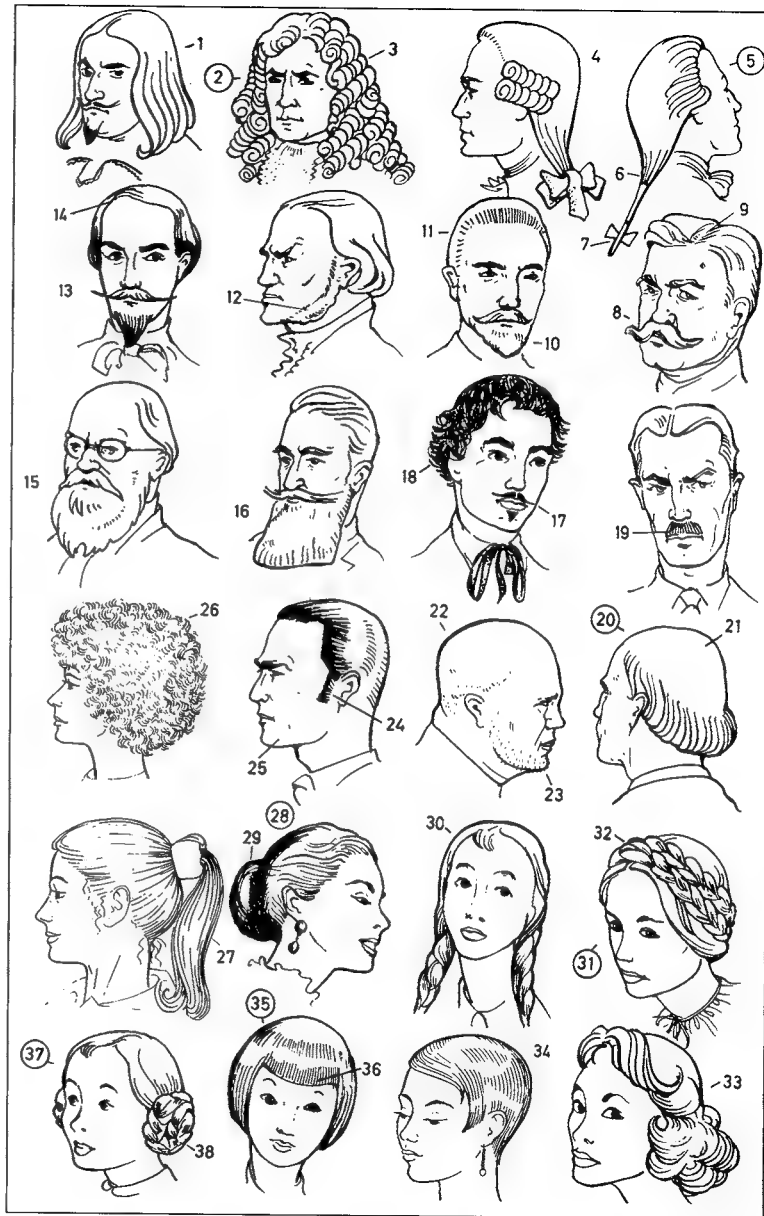

**1-21 ladies' hats and caps**

- 1 milliner making a hat
- 2 hood
- 3 block
- 4 decorative pieces
- 5 sombrero
- 6 mohair hat with feathers
- 7 model hat with fancy appliqué
- 8 linen cap (jockey cap)
- 9 hat made of thick candlewick yarn
- 10 woollen (*Am.* woolen) hat (knitted hat)
- 11 mohair hat
- 12 cloche with feathers
- 13 large men's hat made of sisal with corded ribbon
- 14 trilby-style hat with fancy ribbon
- 15 soft felt hat
- 16 Panama hat with scarf
- 17 peaked mink cap
- 18 mink hat
- 19 fox hat with leather top

20 mink cap

- 21 slouch hat trimmed with flowers

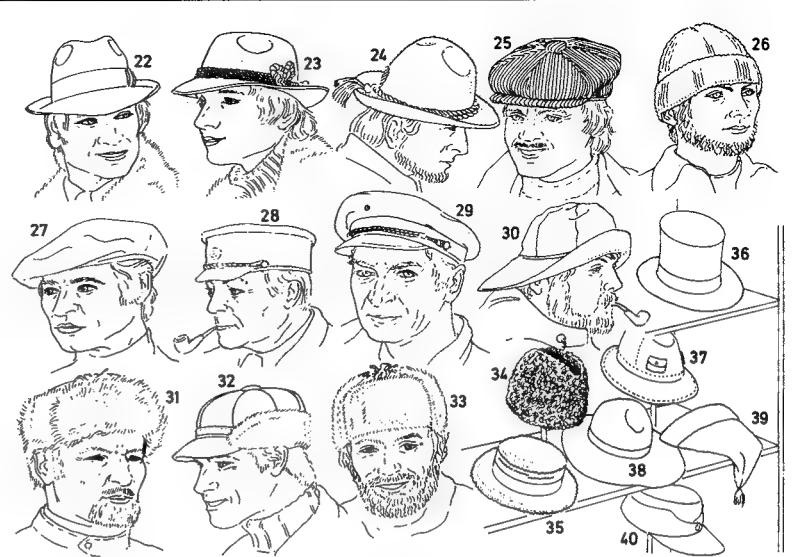
**22-40 men's hats and caps**

- 22 trilby hat (trilby)
- 23 loden hat (Alpine hat)
- 24 felt hat with tassels (Tyrolean hat, Tyrolese hat)
- 25 corduroy cap
- 26 woollen (*Am.* woolen) hat
- 27 beret
- 28 German sailor's cap ('Prinz Heinrich' cap)
- 29 peaked cap (yachting cap)
- 30 sou'wester (southwester)
- 31 fox cap with earflaps
- 32 leather cap with fur flaps
- 33 musquash cap
- 34 astrakhan cap, a real or imitation astrakhan cap
- 35 boater
- 36 (grey, *Am.* gray, or black) top hat made of silk taffeta; *collapsible*: crush hat (opera hat, claque)
- 37 sun hat (lightweight hat) made of cloth with small patch pocket
- 38 wide-brimmed hat
- 39 toboggan cap (skiing cap, ski cap)
- 40 workman's cap

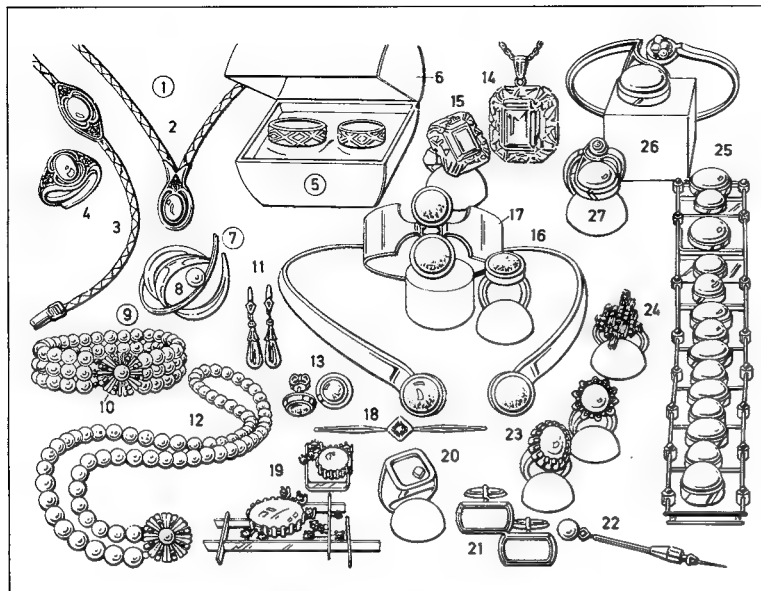

- | | |
|-------------------------------------|------------------------------|
| 1 set of jewellery (Am. jewelry) | 24 modern-style diamond ring |
| 2 necklace | 25 gemstone bracelet |
| 3 bracelet | 26 asymmetrical bangle |
| 4 ring | 27 asymmetrical ring |
| 5 wedding rings | 28 ivory necklace |
| 6 wedding ring box | 29 ivory rose |
| 7 brooch, a pearl brooch | 30 ivory brooch |
| 8 pearl | 31 jewel box (jewel case) |
| 9 cultured pearl bracelet | 32 pearl necklace |
| 10 clasp, a white gold clasp | 33 bracelet watch |
| 11 pendant earrings (drop earrings) | 34 coral necklace |
| 12 cultured pearl necklace | 35 charms |
| 13 earrings | 36 coin bracelet |
| 14 gemstone pendant | 37 gold coin |
| 15 gemstone ring | 38 coin setting |
| 16 choker (collar, neckband) | 39 link |
| 17 bangle | 40 signet ring |
| 18 diamond pin | 41 engraving (monogram) |
| 19 modern-style brooches | 42-86 cuts and forms |
| 20 man's ring | |
| 21 cuff links | |
| 22 tiepin | |
| 23 diamond ring with pearl | |

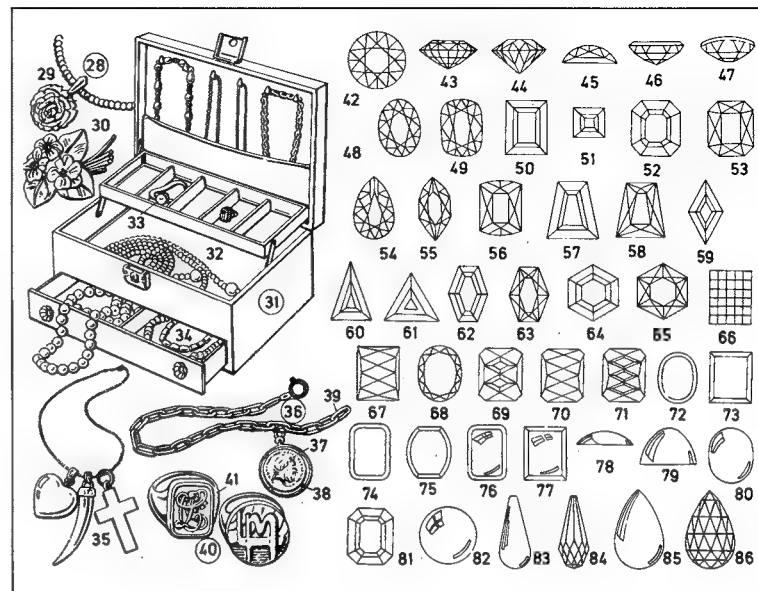

- | | |
|-------------------------------------|-------------------------------------|
| 42-71 faceted stones | 76 antique table en cabochon |
| 42, 43 standard round cut | 77 rectangular table en cabochon |
| 44 brilliant cut | 78-81 cabochons |
| 45 rose cut | 78 round cabochon (simple cabochon) |
| 46 flat table | 79 high dome (high cabochon) |
| 47 table en cabochon | 80 oval cabochon |
| 48 standard cut | 81 octagonal cabochon |
| 49 standard antique cut | 82-86 spheres and pear-shapes |
| 50 rectangular step-cut | 82 plain sphere |
| 51 square step-cut | 83 plain pear-shape |
| 52 octagonal step-cut | 84 faceted pear-shape |
| 53 octagonal cross-cut | 85 plain drop |
| 54 standard pear-shape (pendeloque) | 86 faceted briolette |
| 55 marquise (navette) | |
| 56 standard barrel-shape | |
| 57 trapezium step-cut | |
| 58 trapezium cross-cut | |
| 59 rhombus step-cut | |
| 60, 61 triangular step-cut | |
| 62 hexagonal step-cut | |
| 63 oval hexagonal cross-cut | |
| 64 round hexagonal step-cut | |
| 65 round hexagonal cross-cut | |

1-53 detached house

- 1 basement
- 2 ground floor (*Am.* first floor)
- 3 upper floor (first floor, *Am.* second floor)
- 4 loft
- 5 roof, ▢ gable roof (saddle roof, saddle-back roof)
- 6 gutter
- 7 ridge
- 8 verge with bargeboards
- 9 eaves, rafter-supported eaves
- 10 chimney
- 11 gutter
- 12 swan's neck (swan-neck)
- 13 rainwater pipe (downpipe, *Am.* down-spout, leader)
- 14 vertical pipe, a cast-iron pipe
- 15 gable (gable end)
- 16 glass wall
- 17 base course (plinth)
- 18 balcony
- 19 parapet
- 20 flower box
- 21 French window (French windows) opening on to the balcony
- 22 double casement window
- 23 single casement window
- 24 window breast with window sill
- 25 lintel (window head)
- 26 reveal
- 27 cellar window
- 28 rolling shutter
- 29 rolling shutter frame
- 30 window shutter (folding shutter)
- 31 shutter catch
- 32 garage with tool shed
- 33 espalier
- 34 batten door (ledged door)
- 35 fanlight with mullion and transom
- 36 terrace
- 37 garden wall with coping stones
- 38 garden light
- 39 steps
- 40 rockery (rock garden)
- 41 outside tap (*Am.* faucet) for the hose
- 42 garden hose
- 43 lawn sprinkler
- 44 paddling pool
- 45 stepping stones
- 46 sunbathing area (lawn)
- 47 deck-chair
- 48 sunshade (garden parasol)
- 49 garden chair
- 50 garden table
- 51 frame for beating carpets

- 52 garage driveway
- 53 fence, a wooden fence
- 54-57 housing estate (housing development)
- 54 house on a housing estate (on a housing development)
- 55 pent roof (penthouse roof)
- 56 dormer (dormer window)
- 57 garden
- 58-63 terraced house [one of a row of terraced houses], **stepped**
- 58 front garden
- 59 hedge
- 60 pavement (*Am.* sidewalk, walkway)
- 61 street (road)
- 62 street lamp (street light)
- 63 litter bin (*Am.* trash bin)
- 64-68 house divided into two flats (*Am.* house divided into two apartments, duplex house)
- 64 hip (hipped) roof
- 65 front door
- 66 front steps
- 67 canopy
- 68 flower window (window for house plants)
- 69-71 pair of semi-detached houses divided into four flats (*Am.* apartments)
- 69 balcony
- 70 sun lounge (*Am.* sun parlor)
- 71 awning (sun blind, sunshade)
- 72-76 block of flats (*Am.* apartment building, apartment house) with access balconies
- 72 staircase
- 73 balcony
- 74 studio flat (*Am.* studio apartment)
- 75 sun roof, a sun terrace
- 76 open space
- 77-81 multi-storey block of flats (*Am.* multi-story apartment building, multistory apartment house)
- 77 flat roof
- 78 pent roof (shed roof, lean-to roof)
- 79 garage
- 80 pergola
- 81 staircase window
- 82 high-rise block of flats (*Am.* high-rise apartment building, high-rise apartment house)
- 83 penthouse
- 84-86 weekend house, a timber house
- 84 horizontal boarding
- 85 natural stone base course (natural stone plinth)
- 86 strip windows (ribbon windows)

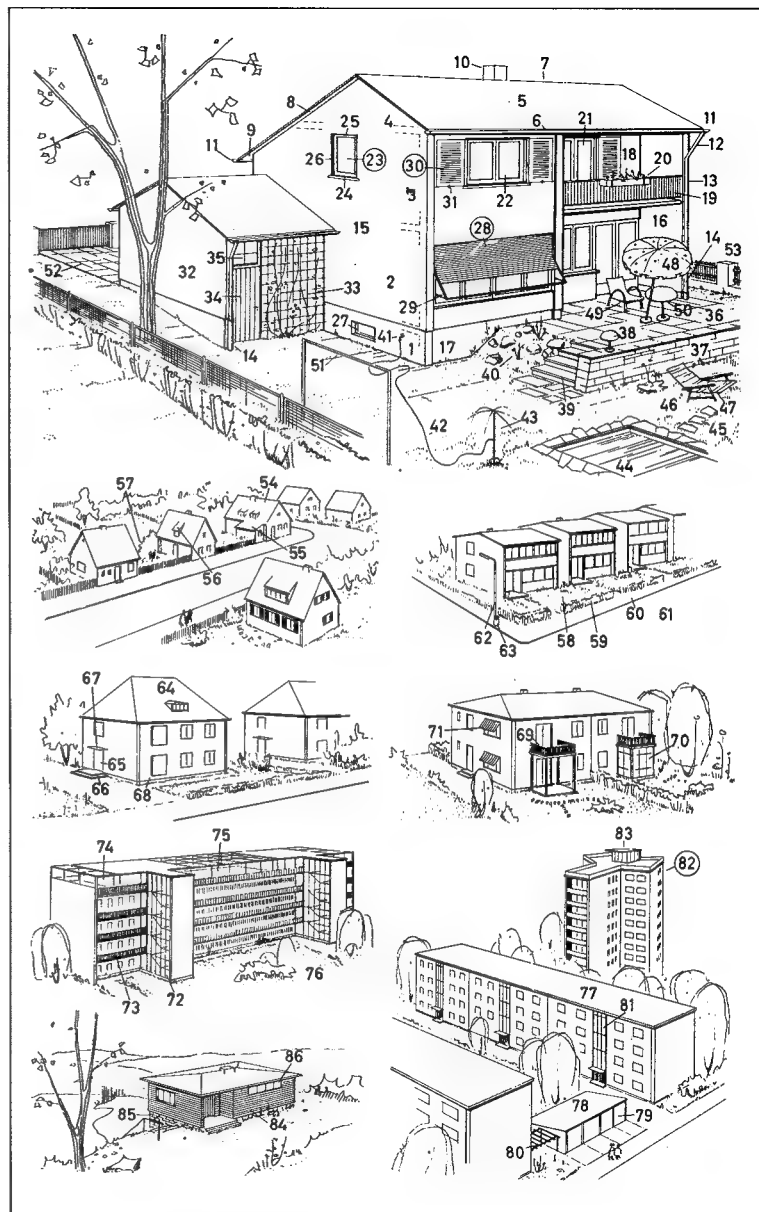

- 1-29 attic
- 1 roof cladding (roof covering)
- 2 skylight
- 3 gangway
- 4 cat ladder (roof ladder)
- 5 chimney
- 6 roof hook
- 7 dormer window (dormer)
- 8 snow guard (roof guard)
- 9 gutter
- 10 rainwater pipe (downpipe, *Am.* downspout, leader)
- 11 eaves
- 12 pitched roof
- 13 trapdoor
- 14 hatch
- 15 ladder
- 16 stile
- 17 rung
- 18 loft (attic)
- 19 wooden partition
- 20 lumber room door (boxroom door)
- 21 padlock
- 22 hook [for washing line]
- 23 clothes line (washing line)
- 24 expansion tank for boiler
- 25 wooden steps and balustrade
- 26 string (*Am.* stringer)
- 27 step
- 28 handrail (guard rail)
- 29 baluster
- 30 lightning conductor (lightning rod)
- 31 chimney sweep (*Am.* chimney sweeper)
- 32 brush with weight
- 33 shoulder iron
- 34 sack for soot
- 35 flue brush
- 36 broom (besom)
- 37 broomstick (broom handle)
- 38-81 hot-water heating system, full central heating
- 38-43 boiler room
- 38 coke-fired central heating system
- 39 ash box door (*Am.* cleanout door)
- 40 flueblock

- 41 poker
- 42 rake
- 43 coal shovel
- 44-60 oil-fired central heating system
- 44 oil tank
- 45 manhole
- 46 manhole cover
- 47 tank inlet
- 48 dome cover
- 49 tank bottom valve
- 50 fuel oil (heating oil)
- 51 air-bleed duct
- 52 air vent cap
- 53 oil level pipe
- 54 oil gauge (*Am.* gage)
- 55 suction pipe
- 56 return pipe
- 57 central heating furnace (oil heating furnace)
- 58-60 oil burner
- 58 fan
- 59 electric motor
- 60 covered pilot light
- 61 charging door
- 62 inspection window
- 63 water gauge (*Am.* gage)
- 64 furnace thermometer
- 65 bleeder
- 66 furnace bed
- 67 control panel
- 68 hot water tank (boiler)
- 69 overflow pipe (overflow)
- 70 safety valve
- 71 main distribution pipe
- 72 lagging
- 73 valve
- 74 flow pipe
- 75 regulating valve
- 76 radiator
- 77 radiator rib
- 78 room thermostat
- 79 return pipe (return)
- 80 return pipe [in two-pipe system]
- 81 smoke outlet (smoke extract)

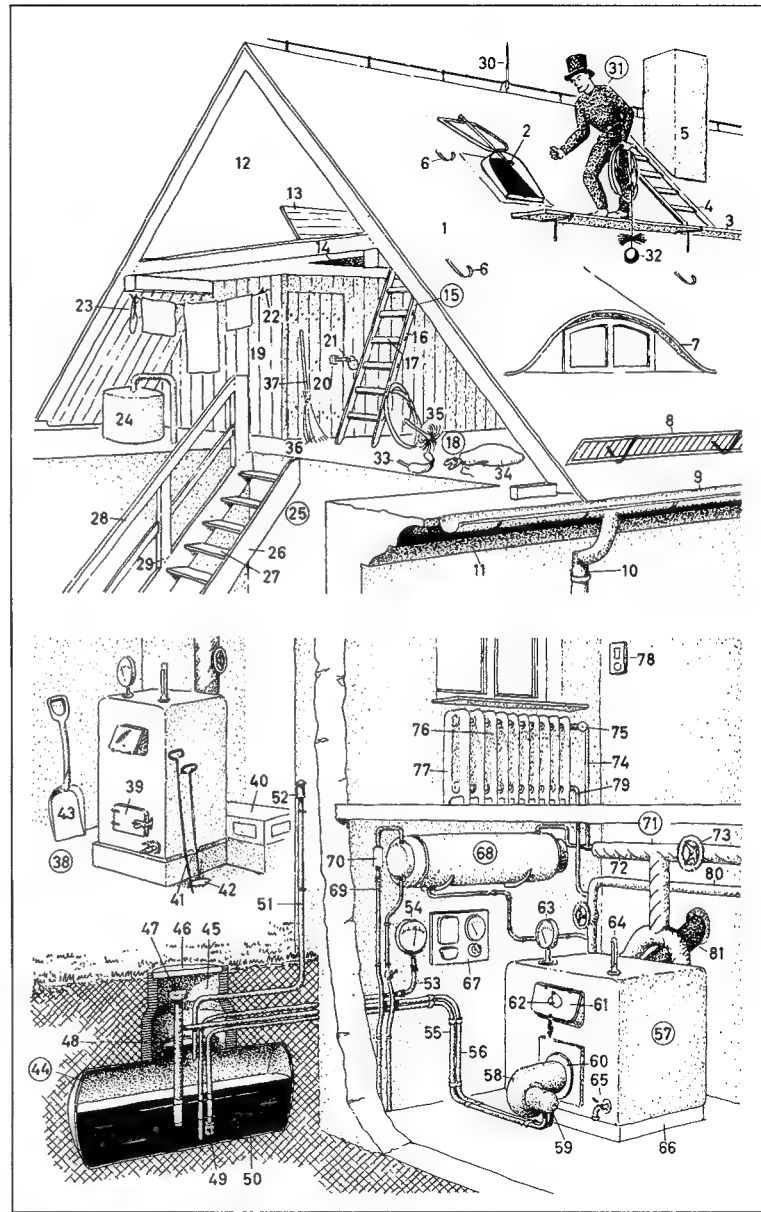

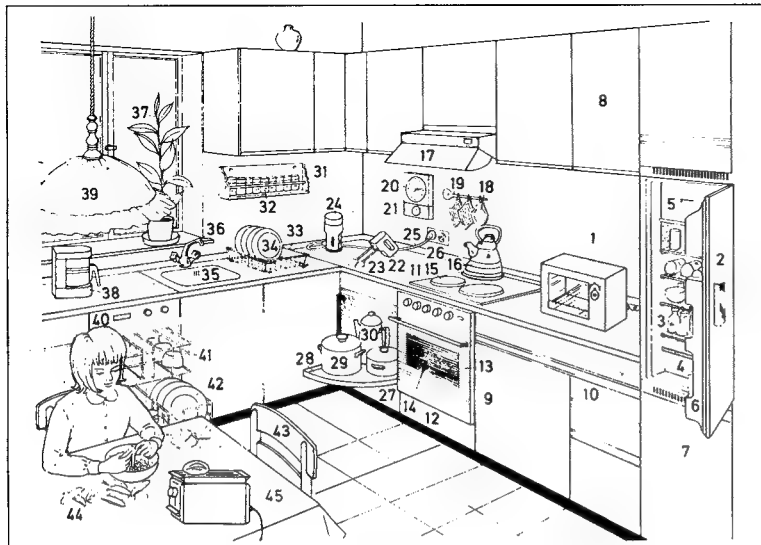

- | | |
|---|---|
| 1 microwave oven (microwave) | 24 electric coffee grinder (with rotating blades) |
| 2 refrigerator (fridge, <i>Am.</i> icebox) | 25 lead |
| 3 refrigerator shelf | 26 wall socket |
| 4 salad drawer | 27 corner unit |
| 5 freezing compartment | 28 revolving shelf |
| 6 bottle rack (in storage door) | 29 pot (cooking pot) |
| 7 upright freezer | 30 jug |
| 8 wall cupboard, a kitchen cupboard | 31 spice rack |
| 9 base unit | 32 spice jar |
| 10 cutlery drawer | 33-36 sink unit |
| 11 work surface (worktop) | 33 dish drainer |
| 12-17 cooker unit | 34 tea plate |
| 12 electric cooker (<i>also:</i> gas cooker) | 35 sink |
| 13 oven | 36 water tap (<i>Am.</i> faucet); <i>here:</i> mixer tap (<i>Am.</i> mixing faucet) |
| 14 oven window | 37 pot plant, a foliage plant |
| 15 hotplate, an automatic high-speed plate | 38 coffee maker |
| 16 kettle (whistling kettle) | 39 kitchen lamp |
| 17 cooker hood | 40 dishwasher (dishwashing machine) |
| 18 pot holder | 41 dish rack |
| 19 pot holder rack | 42 dinner plate |
| 20 kitchen clock | 43 kitchen chair |
| 21 timer | 44 kitchen table |
| 22 hand mixer | 45 toaster |
| 23 whisk | |

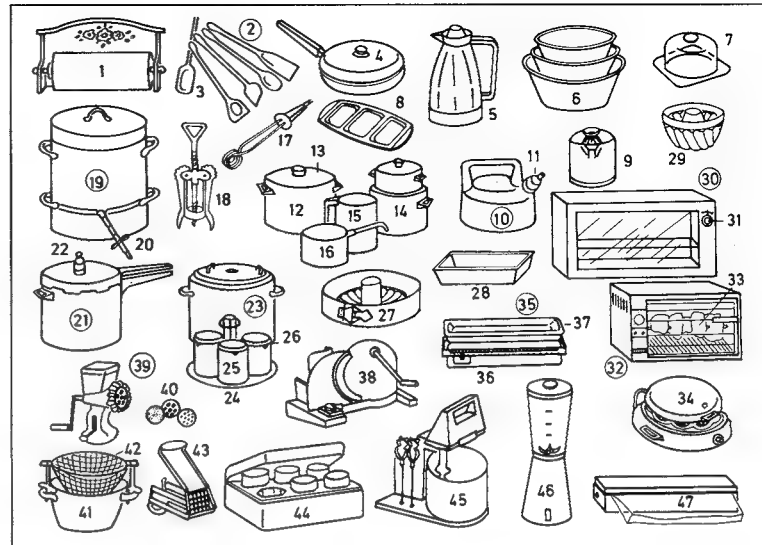

- | | |
|--|--------------------------------------|
| 1 general-purpose roll holder with kitchen roll (paper towels) | 24 removable rack |
| 2 set of wooden spoons | 25 preserving jar |
| 3 mixing spoon | 26 rubber ring |
| 4 frying pan | 27 spring form |
| 5 Thermos jug | 28 cake tin |
| 6 set of bowls | 29 cake tin |
| 7 cheese dish with glass cover | 30 microwave oven (microwave) |
| 8 three-compartment dish | 31 timer |
| 9 lemon squeezer | 32 rotisserie |
| 10 whistling kettle | 33 spit |
| 11 whistle | 34 electric waffle iron |
| 12-16 pan set | 35 sliding-weight scales |
| 12 pot (cooking pot) | 36 sliding weight |
| 13 lid | 37 scale pan |
| 14 casseroles | 38 food slicer |
| 15 milk pot | 39 mincer (<i>Am.</i> meat chopper) |
| 16 saucepan | 40 blades |
| 17 immersion heater | 41 chip pan |
| 18 corkscrew [with levers] | 42 basket |
| 19 juice extractor | 43 potato chipper |
| 20 tube clamp (tube clip) | 44 yoghurt maker |
| 21 pressure cooker | 45 mixer |
| 22 pressure valve | 46 blender |
| 23 fruit preserver | 47 bag sealer |

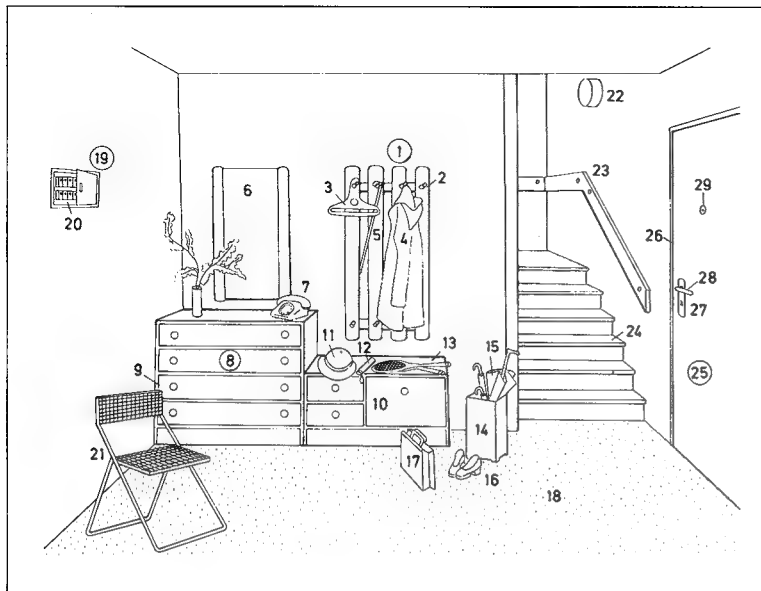
**1-29 hall (entrance hall)**

- | | |
|-------------------------------------|----------------|
| 1 coat rack | 23 handrail |
| 2 coat hook | 24 step |
| 3 coat hanger | 25 front door |
| 4 rain cape | 26 door frame |
| 5 walking stick | 27 door lock |
| 6 hall mirror | 28 door handle |
| 7 telephone | 29 spyhole |
| 8 chest of drawers for shoes, etc. | |
| 9 drawer | |
| 10 seat | |
| 11 ladies' hat | |
| 12 telescopic umbrella | |
| 13 tennis rackets (tennis racquets) | |
| 14 umbrella stand | |
| 15 umbrella | |
| 16 shoes | |
| 17 briefcase | |
| 18 fitted carpet | |
| 19 fuse box | |
| 20 miniature circuit breaker | |
| 21 tubular steel chair | |
| 22 stair light | |

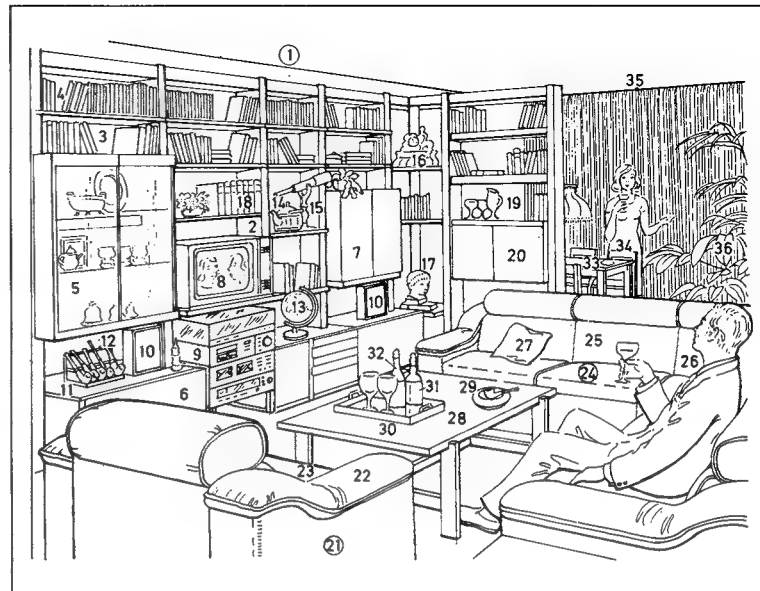
**1-20 wall units (shelf units)**

- | | |
|--|------------------------------------|
| 2 side wall | 21 armchair |
| 3 bookshelf | 22 arm |
| 4 row of books | 23 seat cushion (cushion) |
| 5 display cabinet unit | 24 settee |
| 6 cupboard base unit | 25 back cushion |
| 7 cupboard unit | 26 [round] corner section |
| 8 television set (TV set) | 27 scatter cushion |
| 9 stereo system (stereo equipment) | 28 coffee table |
| 10 speaker (loudspeaker) | 29 ashtray |
| 11 pipe rack | 30 tray |
| 12 pipe | 31 whisky (whiskey) bottle |
| 13 globe | 32 soda water bottle (soda bottle) |
| 14 brass kettle | 33-34 dining set |
| 15 telescope | 33 dining table |
| 16 mantle clock | 34 chair |
| 17 bust | 35 net curtain |
| 18 encyclopaedia [in several volumes] | 36 indoor plants (houseplants) |
| 19 room divider | |
| 20 drinks cupboard | |
| 21-26 upholstered suite (seating group) | |

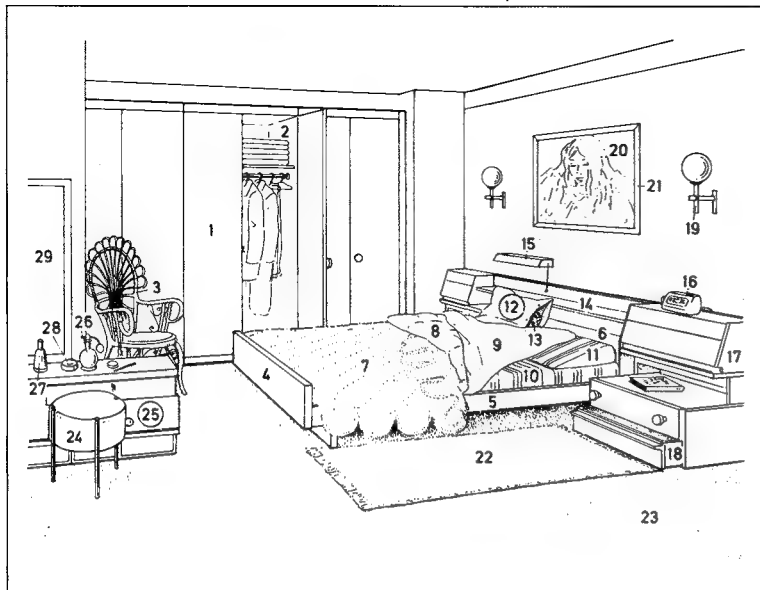

- | | |
|---|-----------------------------------|
| 1 wardrobe (<i>Am.</i> clothes closet) | 19 bedroom lamp |
| 2 linen shelf | 20 picture |
| 3 cane chair | 21 picture frame |
| 4-13 double bed (<i>sim.</i> : double divan) | 22 bedside rug |
| 4-6 bedstead | 23 fitted carpet |
| 4 foot of the bed | 24 dressing stool |
| 5 bed frame | 25 dressing table |
| 6 headboard | 26 perfume spray |
| 7 bedspread | 27 perfume bottle |
| 8 duvet, a quilted duvet | 28 powder box |
| 9 sheet, a linen sheet | 29 dressing-table mirror (mirror) |
| 10 mattress, a foam mattress with drill tick | |
| 11 [wedge-shaped] bolster | |
| 12, 13 pillow | |
| 12 pillowcase (pillowslip) | |
| 13 tick | |
| 14 bookshelf [attached to the headboard] | |
| 15 reading lamp | |
| 16 electric alarm clock | |
| 17 bedside cabinet | |
| 18 drawer | |

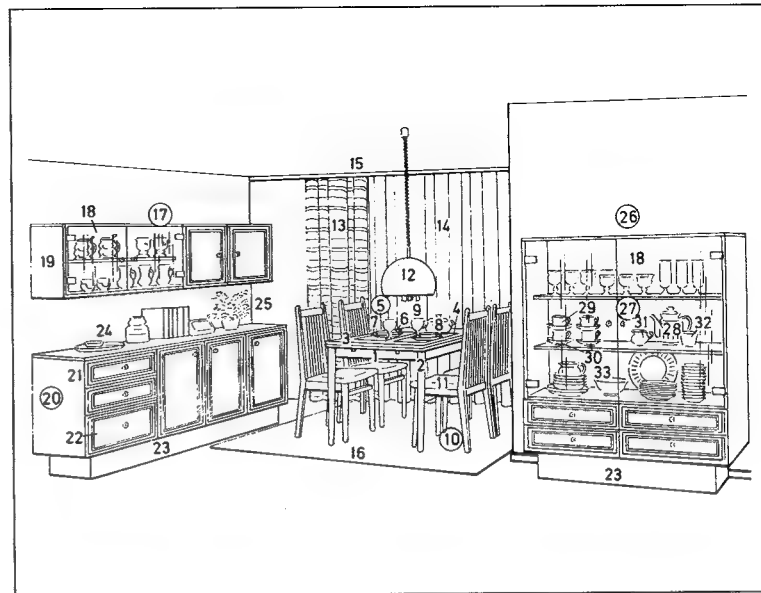

- | | |
|--------------------------------|------------------------------------|
| 1-11 dining set | 23 base |
| 1 dining table | 24 round tray |
| 2 table leg | 25 pot plant |
| 3 table top | 26 china cabinet (display cabinet) |
| 4 place mat | 27 coffee set (coffee service) |
| 5 place (place setting, cover) | 28 coffee pot |
| 6 soup plate (deep plate) | 29 coffee cup |
| 7 dinner plate | 30 saucer |
| 8 soup tureen | 31 milk jug |
| 9 wineglass | 32 sugar bowl |
| 10 dining chair | 33 dinner set (dinner service) |
| 11 seat | |
| 12 lamp (pendant lamp) | |
| 13 curtains | |
| 14 net curtain | |
| 15 curtain rail | |
| 16 carpet | |
| 17 wall unit | |
| 18 glass door | |
| 19 shelf | |
| 20 sideboard | |
| 21 cutlery drawer | |
| 22 linen drawer | |

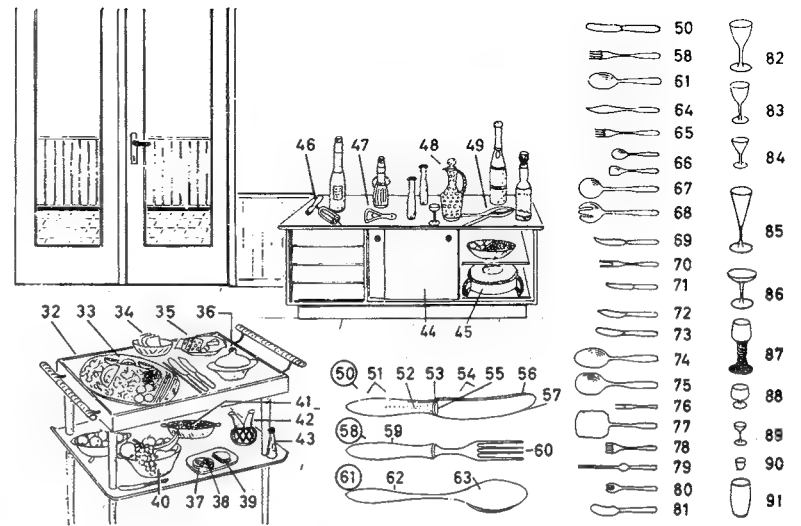
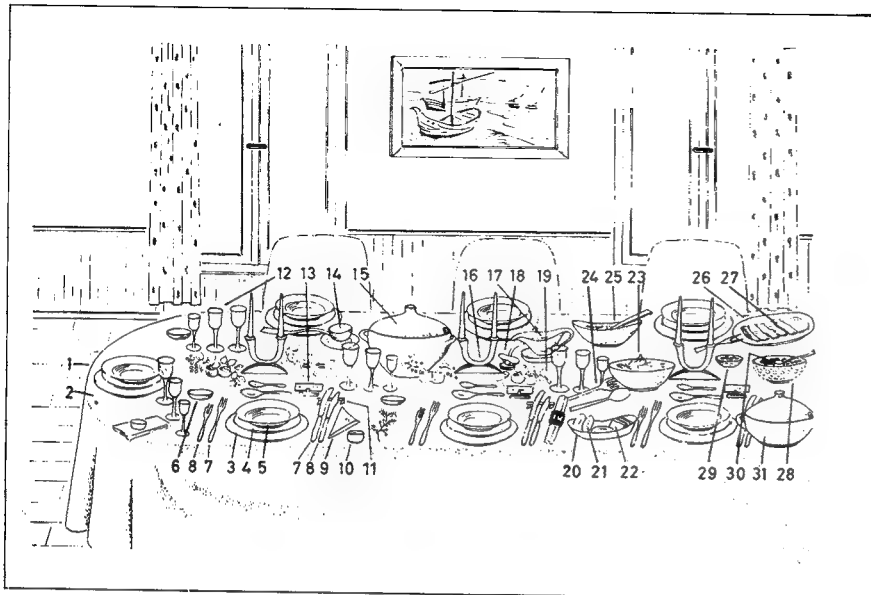

- 1 dining table
- 2 tablecloth, a damask cloth
- 3-12 place (place setting, cover)
- 3 bottom plate
- 4 dinner plate
- 5 deep plate (soup plate)
- 6 dessert plate (dessert bowl)
- 7 knife and fork
- 8 fish knife and fork
- 9 serviette (napkin, table napkin)
- 10 serviette ring (napkin ring)
- 11 knife rest
- 12 wineglasses
- 13 place card
- 14 soup ladle
- 15 soup tureen (tureen)
- 16 candelabra
- 17 sauceboat (gravy boat)
- 18 sauce ladle (gravy ladle)
- 19 table decoration
- 20 bread basket
- 21 roll
- 22 slice of bread
- 23 salad bowl
- 24 salad servers
- 25 vegetable dish
- 26 meat plate (*Am.* meat platter)
- 27 roast meat (roast)
- 28 fruit dish
- 29 fruit bowl
- 30 fruit (stewed fruit)
- 31 potato dish
- 32 serving trolley
- 33 vegetable plate (*Am.* vegetable platter)
- 34 toast
- 35 cheeseboard
- 36 butter dish
- 37 open sandwich
- 38 filling
- 39 sandwich
- 40 fruit bowl
- 41 almonds (*also:* potato crisps, peanuts)
- 42 oil and vinegar bottle
- 43 ketchup (catchup, catsup)
- 44 sideboard
- 45 electric hotplate
- 46 corkscrew
- 47 crown cork bottle opener (crown cork opener), a bottle opener

- 48 liqueur decanter
- 49 nutcrackers (nutcracker)
- 50 knife
- 51 handle
- 52 tang (tongue)
- 53 ferrule
- 54 blade
- 55 bolster
- 56 back
- 57 edge (cutting edge)
- 58 fork
- 59 handle
- 60 prong (tang, tine)
- 61 spoon; *here:* dessert spoon, soup spoon
- 62 handle
- 63 bowl
- 64 fish knife
- 65 fish fork
- 66 dessert spoon (fruit spoon)
- 67 salad spoon
- 68 salad fork
- 69, 70 carving set (serving cutlery)
- 69 carving knife
- 70 serving fork
- 71 fruit knife
- 72 cheese knife
- 73 butter knife
- 74 vegetable spoon, a serving spoon
- 75 potato server (serving spoon for potatoes)
- 76 cocktail fork
- 77 asparagus server (asparagus slice)
- 78 sardine server
- 79 lobster fork
- 80 oyster fork
- 81 caviare knife
- 82 white wine glass
- 83 red wine glass
- 84 sherry glass (madeira glass)
- 85, 86 champagne glasses
- 85 tapered glass
- 86 champagne glass, a crystal glass
- 87 rummer
- 88 brandy glass
- 89 liqueur glass
- 90 spirit glass
- 91 beer glass

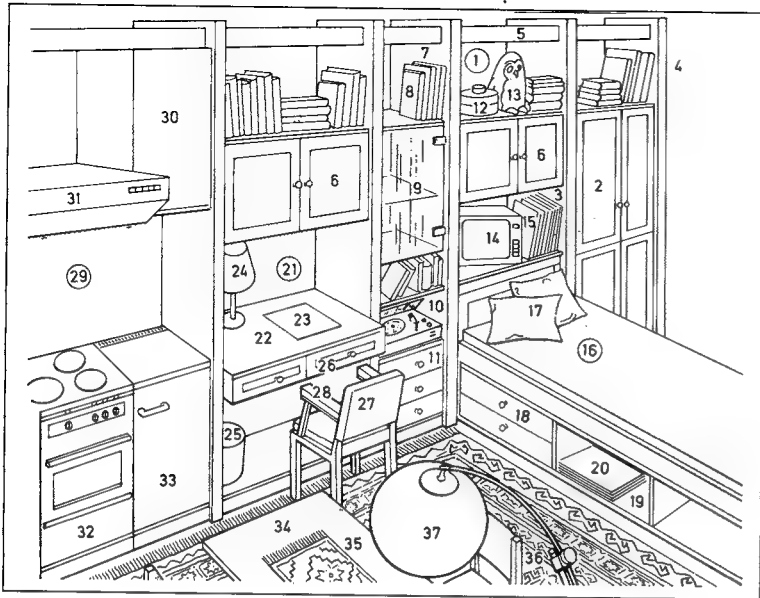

- | | |
|--|---|
| 1 wall units (shelf units) | 22 desk |
| 2 wardrobe door (<i>Am.</i> clothes closet door) | 23 desk mat (blotter) |
| 3 body | 24 table lamp |
| 4 side wall | 25 wastepaper basket |
| 5 trim | 26 desk drawer |
| 6 two-door cupboard unit | 27 desk chair |
| 7 bookshelf unit (bookcase unit) [with glass door] | 28 arm |
| 8 books | 29 kitchen unit |
| 9 display cabinet | 30 wall cupboard |
| 10 record player | 31 cooker hood |
| 11 drawer | 32 electric cooker |
| 12 decorative biscuit tin | 33 refrigerator (fridge, <i>Am.</i> icebox) |
| 13 soft toy animal | 34 dining table |
| 14 television set (TV set) | 35 table runner |
| 15 records (discs) | 36 oriental carpet |
| 16 bed unit | 37 standard lamp |
| 17 scatter cushion | |
| 18 bed unit drawer | |
| 19 bed unit shelf | |
| 20 magazines | |
| 21 desk unit (writing unit) | |

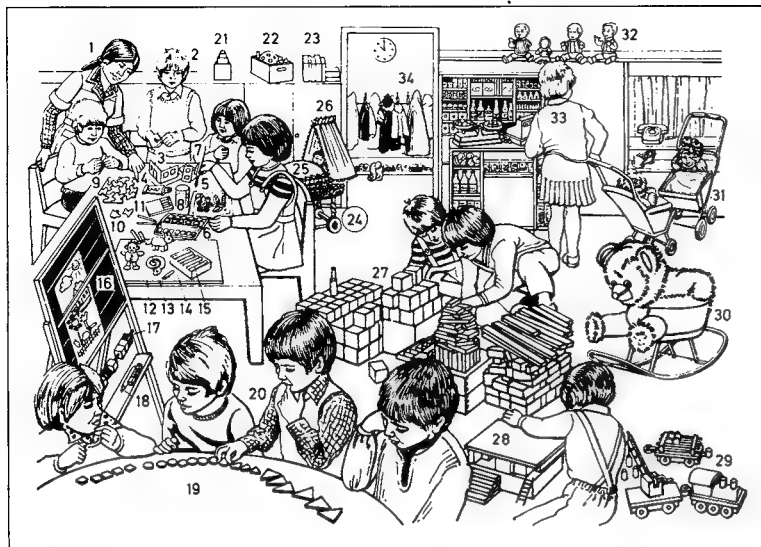

- | | |
|--|---|
| 1 children's bed, a bunk bed | 24 notebook (exercise book) |
| 2 storage box | 25 school books |
| 3 mattress | 26 pencil (<i>also:</i> crayon, felt tip pen, ballpoint pen) |
| 4 pillow | 27 toy shop |
| 5 ladder | 28 counter |
| 6 soft toy elephant, a cuddly toy animal | 29 spice rack |
| 7 soft toy dog | 30 display |
| 8 cushion | 31 assortment of sweets (<i>Am.</i> candies) |
| 9 fashion doll | 32 bag of sweets (<i>Am.</i> candies) |
| 10 doll's pram | 33 scales |
| 11 sleeping doll | 34 cash register |
| 12 canopy | 35 toy telephone |
| 13 blackboard | 36 shop shelves (goods shelves) |
| 14 counting beads | 37 wooden train set |
| 15 toy horse for rocking and pulling | 38 dump truck, a toy lorry (toy truck) |
| 16 rockers | 39 tower crane |
| 17 children's book | 40 concrete mixer |
| 18 compendium of games | 41 large soft toy dog |
| 19 ludo | 42 dice cup |
| 20 chessboard | |
| 21 children's cupboard | |
| 22 linen drawer | |
| 23 drop-flap writing surface | |

1-20 pre-school education (nursery education)

- 1 nursery teacher
- 2 nursery child
- 3 handicraft
- 4 glue
- 5 watercolour (*Am.* watercolor) painting
- 6 paintbox
- 7 paintbrush
- 8 glass of water
- 9 jigsaw puzzle (puzzle)
- 10 jigsaw puzzle piece
- 11 coloured (*Am.* colored) pencils (wax crayons)
- 12 modelling (*Am.* modeling) clay (Plasticine)
- 13 clay figures (Plasticine figures)
- 14 modelling (*Am.* modeling) board
- 15 chalk (blackboard chalk)
- 16 blackboard
- 17 counting blocks
- 18 felt pen (felt tip pen)
- 19 shapes game

20 group of players
21-32 toys

- 21 building and filling cubes
- 22 construction set
- 23 children's books
- 24 doll's pram, a wicker pram
- 25 baby doll
- 26 canopy
- 27 building bricks (building blocks)
- 28 wooden model building
- 29 wooden train set
- 30 rocking teddy bear
- 31 doll's pushchair
- 32 fashion doll
- 33 child of nursery school age
- 34 cloakroom

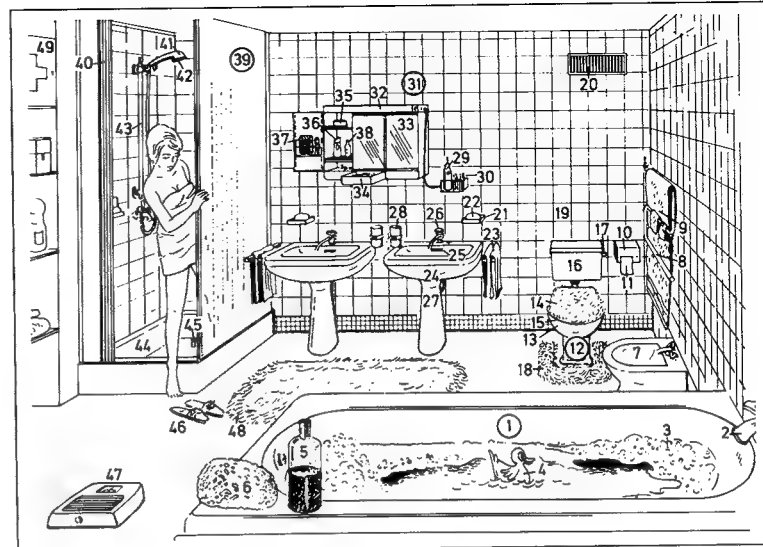

- 1 bath
- 2 mixer tap (*Am.* mixing faucet) for hot and cold water
- 3 foam bath (bubble bath)
- 4 toy duck
- 5 bath salts
- 6 bath sponge (sponge)
- 7 bidet
- 8 towel rail
- 9 terry towel
- 10 toilet roll holder (*Am.* bathroom tissue holder)
- 11 toilet paper (*coll.* loo paper, *Am.* bathroom tissue)
- 12 toilet (lavatory, *W.C.*, *coll.* loo)
- 13 toilet pan (toilet bowl)
- 14 toilet lid with terry cover
- 15 toilet seat
- 16 cistern
- 17 flushing lever
- 18 pedestal mat
- 19 tile
- 20 ventilator (extraction vent)
- 21 soap dish
- 22 soap
- 23 hand towel
- 24 washbasin

25 overflow

- 25 hot and cold water tap
- 27 washbasin pedestal with trap (anti-siphon trap)
- 28 tooth glass (tooth mug)
- 29 electric toothbrush
- 30 detachable brush heads
- 31 mirrored bathroom cabinet
- 32 fluorescent lamp
- 33 mirror
- 34 drawer
- 35 powder box
- 36 mouthwash
- 37 electric shaver
- 38 aftershave lotion
- 39 shower cubicle
- 40 shower curtain
- 41 adjustable shower head
- 42 shower nozzle
- 43 shower adjustment rail
- 44 shower base
- 45 waste pipe
- 46 bathroom mule
- 47 bathroom scales
- 48 bath mat
- 49 medicine cabinet

- 1-20 irons
- 1 electric ironing machine
- 2 electric foot switch
- 3 roller covering
- 4 ironing head
- 5 sheet
- 6 electric iron (lightweight iron)
- 7 sole-plate
- 8 temperature selector
- 9 handle (iron handle)
- 10 pilot light
- 11 steam, spray, and dry iron
- 12 filling inlet
- 13 spray nozzle for damping the washing
- 14 steam hole (steam slit)
- 15 ironing table
- 16 ironing board (ironing surface)
- 17 ironing-board cover
- 18 iron well
- 19 aluminium (*Am.* aluminum) frame
- 20 sleeve board
- 21 linen bin
- 22 dirty linen
- 23-34 washing machines and driers
- 23 automatic washing machine
- 24 washing drum
- 25 safety latch (safety catch)
- 26 program selector control
- 27 front soap dispenser [with several compartments]
- 28 tumble drier
- 29 drum
- 30 front door with ventilation slits
- 31 worktop
- 32 ailer
- 33 clothes line (washing line)
- 34 extending ailer
- 35 stepladder (steps), an aluminium (*Am.* aluminum) ladder
- 36 stile
- 37 prop
- 38 tread (rung)
- 39-43 shoe care utensils
- 39 tin of shoe polish
- 40 shoe spray, an impregnating spray
- 41 shoe brush
- 42 brush for applying polish
- 43 tube of shoe polish
- 44 clothes brush
- 45 carpet brush

- 46 broom
- 47 bristles
- 48 broom head
- 49 broomstick (broom handle)
- 50 screw thread
- 51 washing-up brush
- 52 pan (dustpan)
- 53-86 floor and carpet cleaning
- 53 brush
- 54 bucket (pail)
- 55 floor cloth (cleaning rag)
- 56 scrubbing brush
- 57 carpet sweeper
- 58 upright vacuum cleaner
- 59 changeover switch
- 60 swivel head
- 61 bag-full indicator
- 62 dust bag container
- 63 handle
- 64 tubular handle
- 65 flex hook
- 66 wound-up flex
- 67 all-purpose nozzle
- 68 cylinder vacuum cleaner
- 69 swivel coupling
- 70 extension tube
- 71 floor nozzle (*sim.*: carpet beater nozzle)
- 72 suction control
- 73 bag-full indicator
- 74 sliding fingertip suction control
- 75 hose (suction hose)
- 76 combined carpet sweeper and shampooer
- 77 electric lead (flex)
- 78 plug socket
- 79 carpet beater head (*sim.*: shampooing head, brush head)
- 80 all-purpose vacuum cleaner (wet and dry vacuum cleaner)
- 81 castor
- 82 motor unit
- 83 lid clip
- 84 coarse dirt hose
- 85 special accessory (special attachment) for coarse dirt
- 86 dust container
- 87 shopper (shopping trolley)

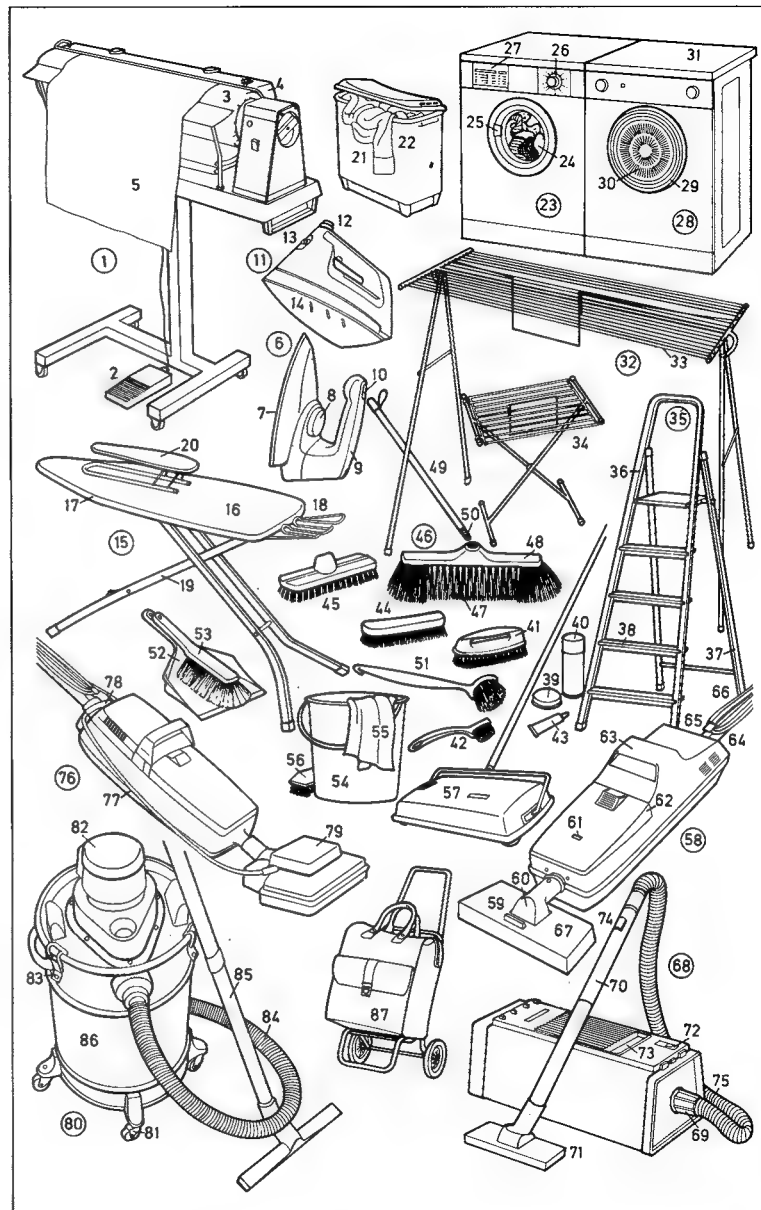

51 Flower Garden

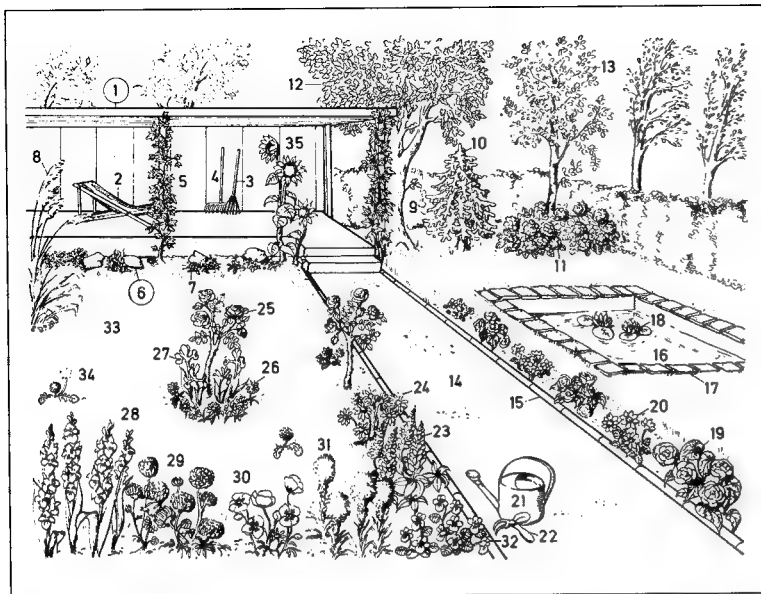

1-35 flower garden

- 1 pergola
- 2 deck-chair
- 3 lawn rake (wire-tooth rake)
- 4 garden rake
- 5 Virginia creeper (American ivy, woodbine), a climbing plant (climber, creeper)
- 6 rockery (rock garden)
- 7 rock plants; *varieties*: stoncrop (wall pepper), houseleek, dryas, aubretia
- 8 pampas grass
- 9 garden hedge
- 10 blue spruce
- 11 hydrangeas
- 12 oak (oak tree)
- 13 birch (birch tree)
- 14 garden path
- 15 edging
- 16 garden pond
- 17 flagstone (stone slab)
- 18 water lily

- 19 tuberous begonias
- 20 dahlias
- 21 watering can (*Am.* sprinkling can)
- 22 weeding hoe
- 23 lupin
- 24 marguerites (oxeye daisies, white oxeye daisies)
- 25 standard rose
- 26 gerbera
- 27 iris
- 28 gladioli
- 29 chrysanthemums
- 30 poppy
- 31 blazing star
- 32 snapdragon (*antirrhinum*)
- 33 lawn
- 34 dandelion
- 35 sunflower

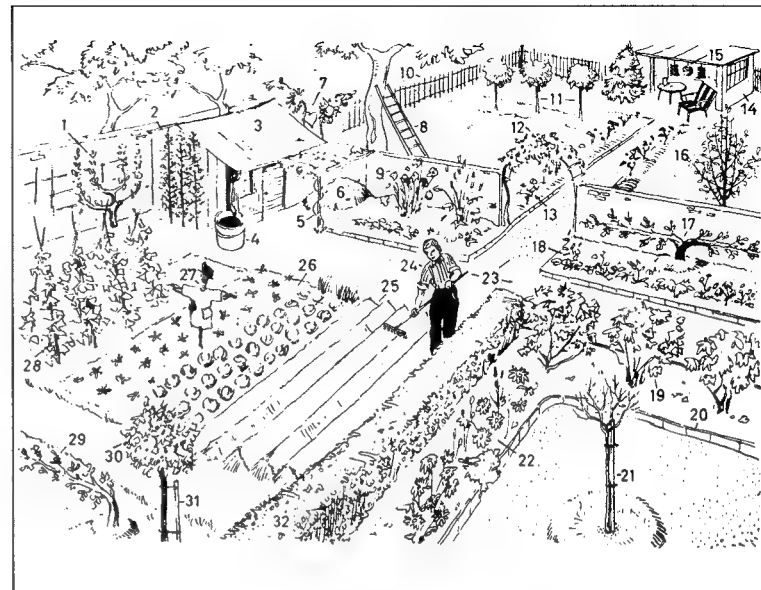

1-32 allotment (fruit and vegetable garden)

1, 2, 16, 17, 29 dwarf fruit trees (espaliers, espalier fruit trees)

- 1 quadruple cordon, a wall espalier
- 2 vertical cordon
- 3 tool shed (garden shed)
- 4 water butt (water barrel)
- 5 climbing plant (climber, creeper, rambler)
- 6 compost heap
- 7 sunflower
- 8 garden ladder (ladder)
- 9 perennial (flowering perennial)
- 10 garden fence (paling fence, paling)
- 11 standard berry tree
- 12 climbing rose (rambling rose) on the trellis arch
- 13 bush rose (standard rose tree)
- 14 summerhouse (garden house)
- 15 Chinese lantern (paper lantern)
- 16 pyramid tree (pyramidal tree, pyramid), a free-standing espalier

- 17 double horizontal cordon
- 18 flower bed, a border
- 19 berry bush (gooseberry bush, currant bush)
- 20 concrete edging
- 21 standard rose (standard rose tree)
- 22 border with perennials
- 23 garden path
- 24 allotment holder
- 25 asparagus patch (asparagus bed)
- 26 vegetable patch (vegetable plot)
- 27 scarecrow
- 28 runner bean (*Am.* scarlet runner), a bean plant on poles (bean poles)
- 29 horizontal cordon
- 30 standard fruit tree
- 31 tree stake
- 32 hedge

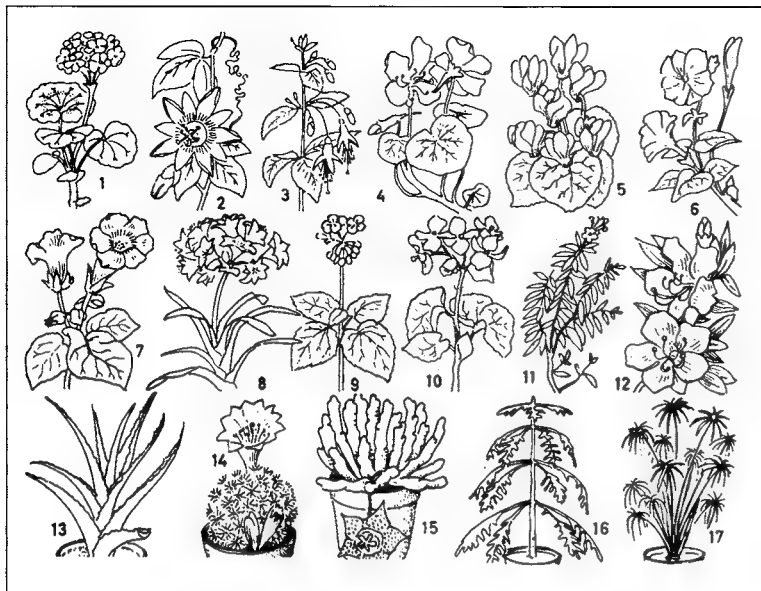

- 1 pelargonium (crane's bill), a geranium
- 2 passion flower (*Passiflora*), a climbing plant (climber, creeper)
- 3 fuchsia, an anagraceous plant
- 4 nasturtium (*Indian cress*, *tropaeolum*)
- 5 cyclamen, a primulaceous herb
- 6 petunia, a solanaceous herb
- 7 gloxinia (*Sinningia*), a gesneriaceous plant
- 8 *Clivia minata*, an amaryllis (*narcissus*)
- 9 African hemp (*Sparmannia*), a tiliaceous plant, a linden plant
- 10 begonia
- 11 myrtle (common myrtle, *Myrtus*)
- 12 azalea, an ericaceous plant
- 13 aloe, a liliaceous plant
- 14 globe thistle (*Echinops*)
- 15 stapelia (*carrion flower*), an asclepiadaceous plant
- 16 Norfolk Island Pine (an araucaria grown as an ornamental)
- 17 galingale, a cyperaceous plant of the sedge family

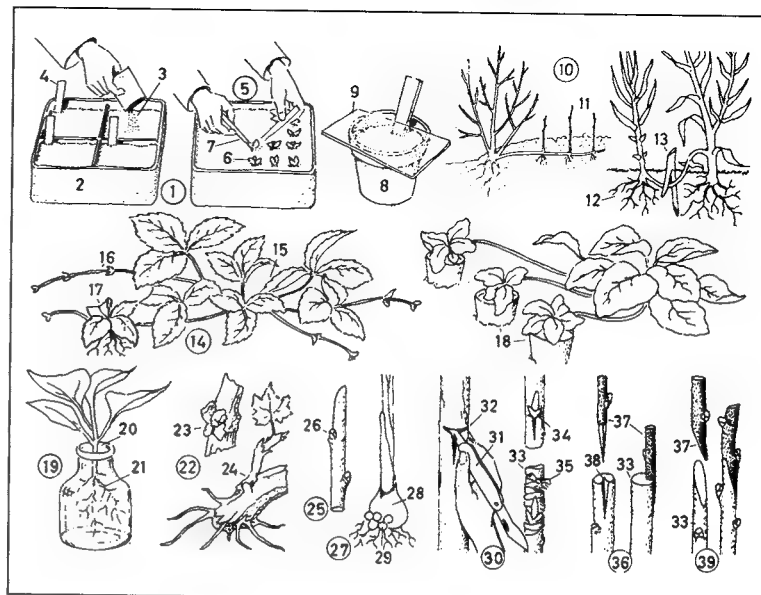

- 1 seed sowing (sowing)
- 2 seed pan
- 3 seed
- 4 label
- 5 pricking out (pricking off, transplanting)
- 6 seedling (seedling plant)
- 7 dibber (dibble)
- 8 flower pot (pot)
- 9 sheet of glass
- 10 propagation by layering
- 11 layer
- 12 layer with roots
- 13 forked stick used for fastening
- 14 propagation by runners
- 15 parent (parent plant)
- 16 runner
- 17 small rooted leaf cluster
- 18 setting in pots
- 19 cutting in water
- 20 cutting (slip, set)
- 21 root
- 22 bud cutting on vine tendril
- 23 scion bud, a bud
- 24 sprouting (shooting) cutting
- 25 stem cutting (hardwood cutting)
- 26 bud
- 27 propagation by bulbils (brood bud bulblets)
- 28 old bulb
- 29 bulbil (brood bud bulblet)
- 30-39 grafting (graftage)
- 30 budding; here: shield budding
- 31 budding knife
- 32 T-cut
- 33 support (stock, rootstock)
- 34 inserted scion bud
- 35 raffia layer (bast layer)
- 36 side grafting
- 37 scion (shoot)
- 38 wedge-shaped notch
- 39 splice grafting

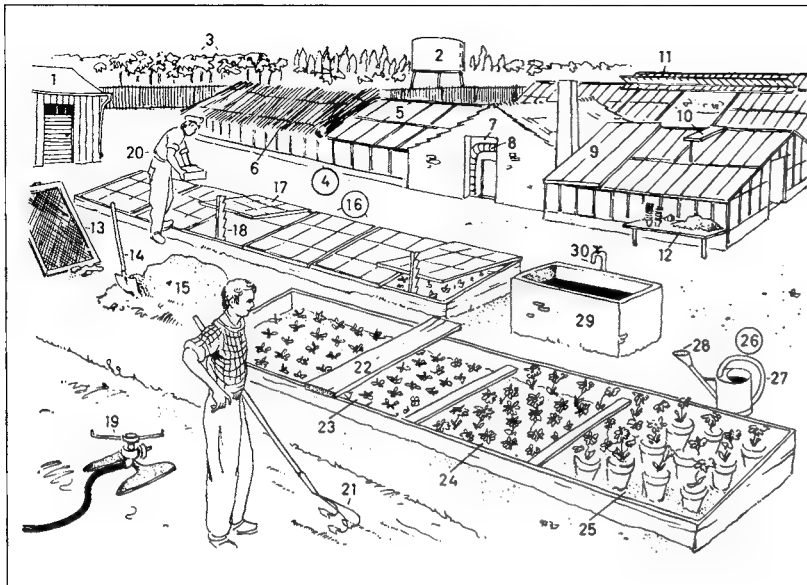

1-51 market garden (Am. truck garden, truck farm)

- | | |
|---|---|
| 1 tool shed | 15 heap of earth (composted earth, prepared earth, garden mould, Am. mold) |
| 2 water tower (water tank) | 16 hotbed (forcing bed, heated frame) |
| 3 market garden (Am. truck garden, truck farm), a tree nursery | 17 hotbed vent (frame vent) |
| 4 hothouse (forcing house, warm house) | 18 vent prop |
| 5 glass roof | 19 sprinkler (sprinkling device) |
| 6 [roll of] matting (straw matting, reed matting, shading) | 20 gardener (nursery gardener, grower, commercial grower) |
| 7 boiler room (boiler house) | 21 cultivator (hand cultivator, grubber) |
| 8 heating pipe (pressure pipe) | 22 plank |
| 9 shading panel (shutter) | 23 pricked-out seedlings (pricked-off seedlings) |
| 10, 11 ventilators (vents) | 24 forced flowers [forcing] |
| 10 ventilation window (window vent, hinged ventilator) | 25 potted plants (plants in pots, pot plants) |
| 11 ridge vent | 26 watering can (Am. sprinkling can) |
| 12 potting table (potting bench) | 27 handle |
| 13 riddle (sieve, garden sieve, upright sieve) | 28 rose |
| 14 garden shovel (shovel) | 29 water tank |
| | 30 water pipe |



- | |
|---|
| 31 bale of peat |
| 32 warm house (heated greenhouse) |
| 33 cold house (unheated greenhouse) |
| 34 wind generator |
| 35 wind wheel |
| 36 wind vane |
| 37 shrub bed, a flower bed |
| 38 hoop edging |
| 39 vegetable plot |
| 40 plastic tunnel (polythene greenhouse) |
| 41 ventilation flap |
| 42 central path |
| 43 vegetable crate |
| 44 tomato plant |
| 45, 46 nursery hand |
| 47 tub plant |
| 48 tub |
| 49 orange tree |
| 50 wire basket |
| 51 seedling box |

56 Garden Tools

- 1 dibber (dibble)
- 2 spade
- 3 lawn rake (wire-tooth rake)
- 4 rake
- 5 ridging hoe
- 6 trowel
- 7 combined hoe and fork
- 8 sickle
- 9 gardener's knife (pruning knife, billhook)
- 10 asparagus cutter (asparagus knife)
- 11 tree pruner (long-handled pruner)
- 12 semi-automatic spade
- 13 three-pronged cultivator
- 14 tree scraper (bark scraper)
- 15 lawn aerator (aerator)
- 16 pruning saw (saw for cutting branches)
- 17 battery-operated hedge trimmer
- 18 motor cultivator
- 19 electric drill
- 20 gear
- 21 cultivator attachment
- 22 fruit picker
- 23 tree brush (bark brush)
- 24 sprayer for pest control
- 25 lance
- 26 hose reel (reel and carrying cart)
- 27 garden hose
- 28 motor lawn mower (motor mower)
- 29 grassbox
- 30 two-stroke motor
- 31 electric lawn mower (electric mower)
- 32 electric lead (electric cable)
- 33 cutting unit
- 34 hand mower
- 35 cutting cylinder
- 36 blade
- 37 riding mower
- 38 brake lock
- 39 electric starter
- 40 brake pedal
- 41 cutting unit
- 42 tip-up trailer
- 43 revolving sprinkler, a lawn sprinkler

- 44 revolving nozzle
- 45 hose connector
- 46 oscillating sprinkler
- 47 wheelbarrow
- 48 grass shears
- 49 hedge shears
- 50 secateurs (pruning shears)

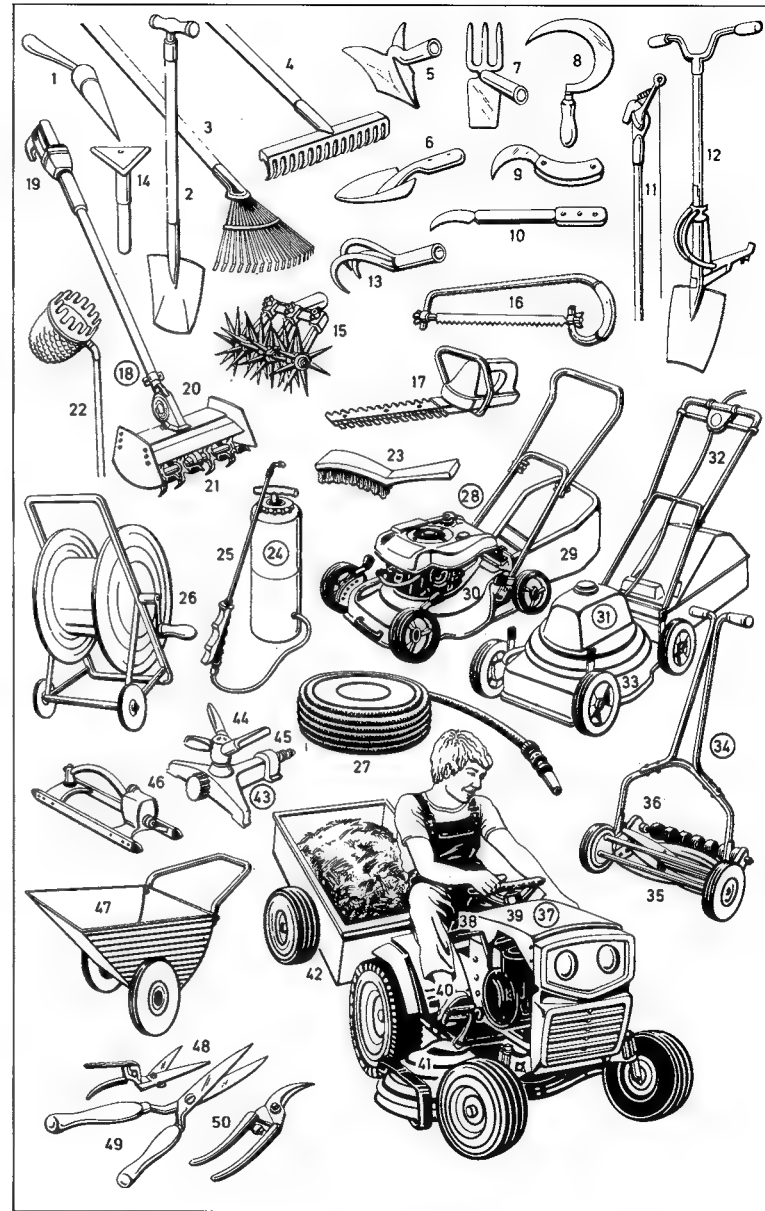

1-11 leguminous plants

(Leguminosae)

- 1 pea, a plant with a papilionaceous corolla
 2 pea flower
 3 pinnate leaf
 4 pea tendril, a leaf tendril
 5 stipule
 6 legume (pod), a seed vessel (pericarp, legume)
 7 pea [seed]
 8 bean plant (bean), a climbing plant (climber, creeper); *varieties*: broad bean (runner bean, *Am.* scarlet runner), climbing bean (climber, pole bean), scarlet runner bean; *smaller*: dwarf French bean (bush bean)
 9 bean flower
 10 twining beanstalk
 11 bean [pod with seeds]
 12 tomato
 13 cucumber
 14 asparagus
 15 radish
 16 white radish
 17 carrot
 18 stump-rooted carrot
 19 parsley
 20 horse-radish
 21 leeks
 22 chives
 23 pumpkin (*Am.* squash); *sim.*: melon
 24 onion
 25 onion skin
 26 kohlrabi
 27 celeriac
28-34 brassicas (leaf vegetables)
 28 chard (Swiss chard, seakale beet)
 29 spinach
 30 Brussels sprouts (sprouts)
 31 cauliflower
 32 cabbage (round cabbage, head of cabbage), a brassica; *cultivated races (cultivars)*: green cabbage, red cabbage

- 33 savoy (savoy cabbage)
 34 kale (curly kale, kail), a winter green
 35 scorzonera (black salsify)
36-40 salad plants
 36 lettuce (cabbage lettuce, head of lettuce)
 37 lettuce leaf
 38 corn salad (lamb's lettuce)
 39 endive (endive leaves)
 40 chicory (succory, salad chicory)
 41 globe artichoke
 42 sweet pepper (Spanish paprika)

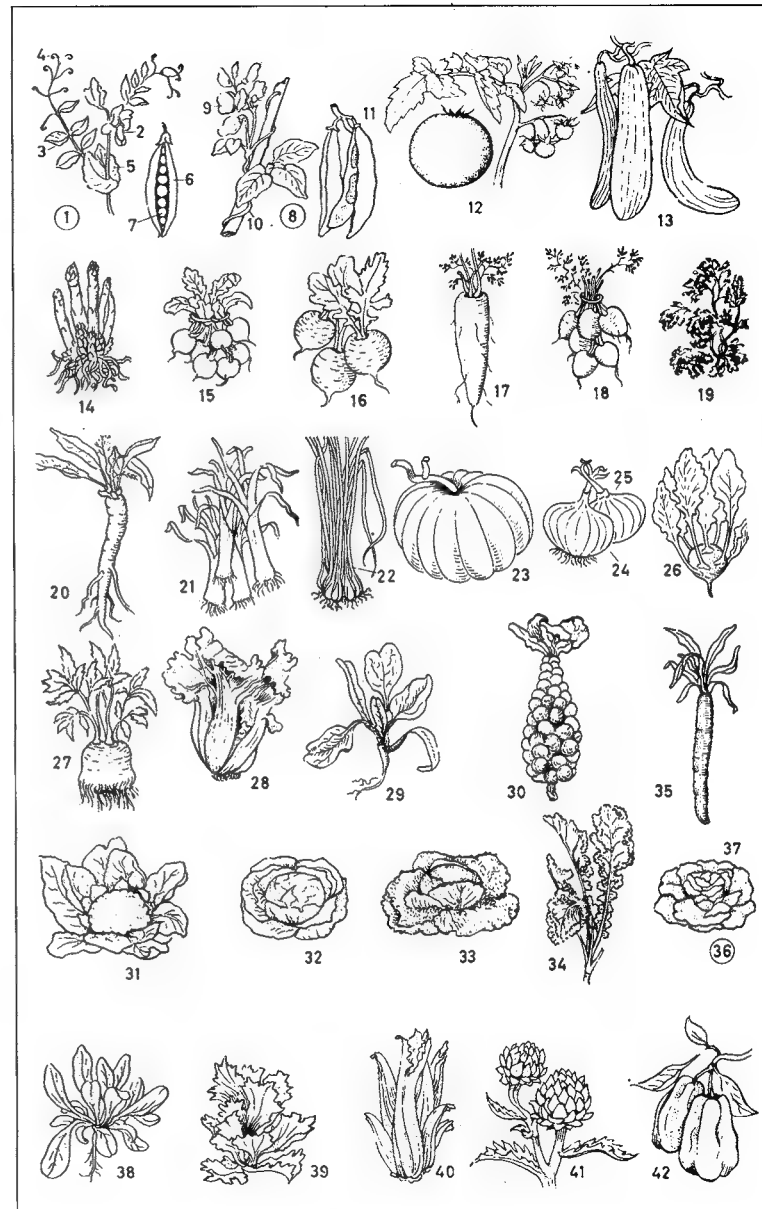

1-30 soft fruit (berry bushes)

1-15 Ribes

- 1 gooseberry bush
 2 flowering gooseberry cane
 3 leaf
 4 flower
 5 magpie moth larva
 6 gooseberry flower
 7 epigynous ovary
 8 calyx (sepals)
 9 gooseberry, a berry
 10 currant bush
 11 cluster of berries
 12 currant
 13 stalk
 14 flowering cane of the currant
 15 raceme
 16 strawberry plant; *varieties*: wild strawberry (woodland strawberry), garden strawberry, alpine strawberry
 17 flowering and fruit-bearing plant
 18 rhizome
 19 ternate leaf (trifoliate leaf)
 20 runner (prostrate stem)
 21 strawberry, a pseudocarp
 22 epicalyx
 23 achene (seed)
 24 flesh (pulp)
 25 raspberry bush
 26 raspberry flower
 27 flower bud (bud)
 28 fruit (raspberry), an aggregate fruit (compound fruit)
 29 blackberry
 30 thorny tendril

31-61 pomiferous plants

- 31 pear tree; *wild*: wild pear tree
 32 flowering branch of the pear tree
 33 pear [longitudinal section]
 34 pear stalk (stalk)
 35 flesh (pulp)
 36 core (carpels)
 37 pear pip (seed), a fruit pip
 38 pear blossom
 39 ovules
 40 ovary

- 41 stigma
 42 style
 43 petal
 44 sepal
 45 stamen
 46 quince tree
 47 quince leaf
 48 stipule
 49 apple-shaped quince [longitudinal section]
 50 pear-shaped quince [longitudinal section]
 51 apple tree; *wild*: crab apple tree
 52 flowering branch of the apple tree
 53 leaf
 54 apple blossom
 55 withered flower
 56 apple [longitudinal section]
 57 apple skin
 58 flesh (pulp)
 59 core (apple core, carpels)
 60 apple pip, a fruit pip
 61 apple stalk (stalk)
 62 codling moth (codlin moth)
 63 burrow (tunnel)
 64 larva (grub, caterpillar) of a small moth
 65 wormhole

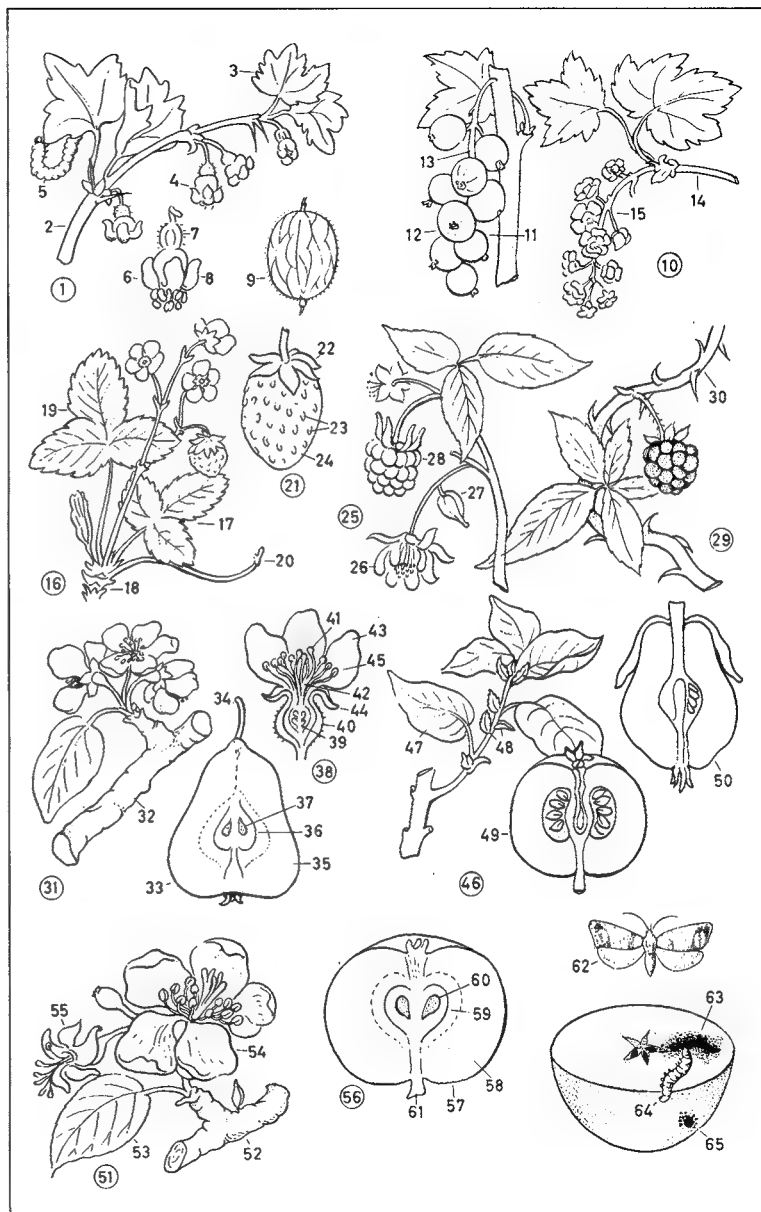

59 Drupes and Nuts

1-36 drupes (drupaceous plants)

1-18 cherry tree

1 flowering branch of the cherry tree
(branch of the cherry tree in blossom)

2 cherry leaf

3 cherry flower (cherry blossom)

4 peduncle (pedicel, flower stalk)

5 cherry; *varieties*: sweet cherry (heart cherry), wild cherry (bird cherry), sour cherry, morello cherry (morello)

6-8 cherry (cherry fruit) [cross section]

6 flesh (pulp)

7 cherry stone

8 seed

9 flower (blossom) [cross section]

10 stamen

11 petal

12 sepal

13 pistil

14 ovule enclosed in perigynous ovary

15 style

16 stigma

17 leaf

18 nectary (honey gland)

19-23 plum tree

19 fruit-bearing branch

20 oval, black-skinned plum

21 plum leaf

22 bud

23 plum stone

24 greengage

25 mirabelle (transparent gage), a plum

26-32 peach tree

26 flowering branch (branch in blossom)

27 peach flower (peach blossom)

28 flower shoot

29 young leaf (sprouting leaf)

30 fruiting branch

31 peach

32 peach leaf

33-36 apricot tree

33 flowering apricot branch (apricot

branch in blossom)

34 apricot flower (apricot blossom)

35 apricot

36 apricot leaf

37-51 nuts

37-43 walnut tree

37 flowering branch of the walnut tree

38 female flower

39 male inflorescence (male flowers, catkins with stamens)

40 alternate pinnate leaf

41 walnut, a drupe (stone fruit)

42 soft shell (cupule)

43 walnut, a drupe (stone fruit)

44-51 hazel tree (hazel bush), an anemophilous shrub (a wind-pollinating shrub)

44 flowering hazel branch

45 male catkin

46 female inflorescence

47 leaf bud

48 fruit-bearing branch

49 hazelnut (hazel, cobnut, cob), a drupe (stone fruit)

50 involucre (husk)

51 hazel leaf

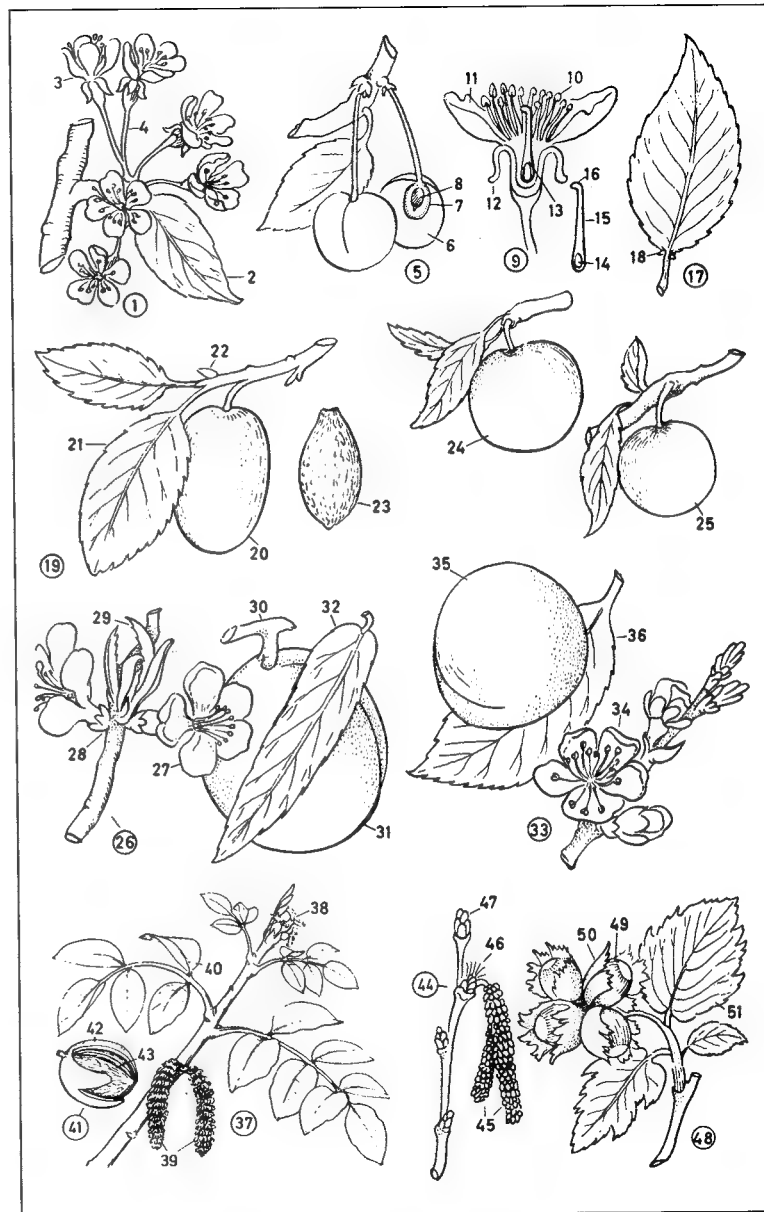

- 1 snowdrop (spring snowflake)
- 2 garden pansy (heartsease pansy), a pansy
- 3 trumpet narcissus (trumpet daffodil, Lent lily), a narcissus
- 4 poet's narcissus (pheasant's eye, poet's daffodil); *sim.*: polyanthus narcissus
- 5 bleeding heart (lyre flower), a fumariaceous flower
- 6 sweet william (bunch pink), a carnation
- 7 gillyflower (gilliflower, clove pink, clove carnation)
- 8 yellow flag (yellow water flag, yellow iris), an iris
- 9 tuberose
- 10 columbine (aquilegia)
- 11 gladiolus (sword lily)
- 12 Madonna lily (Annunciation lily, Lent lily), a lily
- 13 larkspur (delphinium), a ranunculaceous plant
- 14 moss pink (moss phlox), a phlox
- 15 garden rose (China rose)
- 16 rosebud, a bud
- 17 double rose
- 18 rose thorn, a thorn
- 19 gaillardia
- 20 African marigold (tagetes)
- 21 love-lies-bleeding, an amaranthine flower
- 22 zinnia
- 23 pompon dahlia, a dahlia

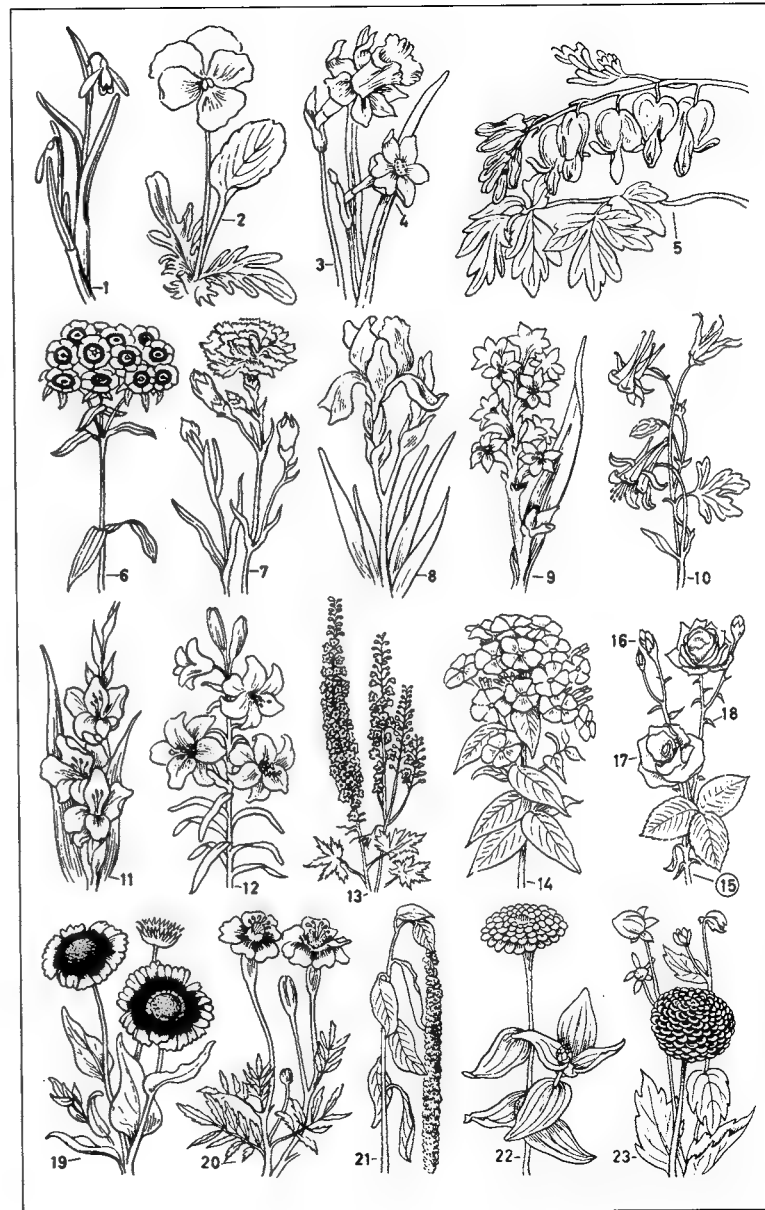

- 1 corn flower (bluebottle), a centaury
- 2 corn poppy (field poppy), a poppy
- 3 bud
- 4 poppy flower
- 5 seed capsule containing poppy seeds
- 6 corn cockle (corn campion, crown-of-the-field)
- 7 corn marigold (field marigold), a chrysanthemum
- 8 corn camomile (field camomile, camomile, chamomile)
- 9 shepherd's purse
- 10 flower
- 11 fruit (pouch-shaped pod)
- 12 common groundsel
- 13 dandelion
- 14 flower head (capitulum)
- 15 infructescence
- 16 hedge mustard, a mustard
- 17 stonecrop
- 18 wild mustard (charlock, runch)
- 19 flower
- 20 fruit, a silique (pod)
- 21 wild radish (jointed charlock)
- 22 flower
- 23 fruit (silique, pod)
- 24 common orache (common orach)
- 25 goosefoot
- 26 field bindweed (wild morning glory), a bindweed
- 27 scarlet pimpernel (shepherd's weatherglass, poor man's weather-glass, eye-bright)
- 28 wild barley (wall barley)
- 29 wild oat
- 30 common couch grass (couch, quack grass, quick grass, quitch grass, scutch grass, twitch grass, witch-grass); *sim.*: bearded couch grass, sea couch grass
- 31 gallant soldier
- 32 field eryngo (Watling Street thistle), a thistle
- 33 stinging nettle, a nettle

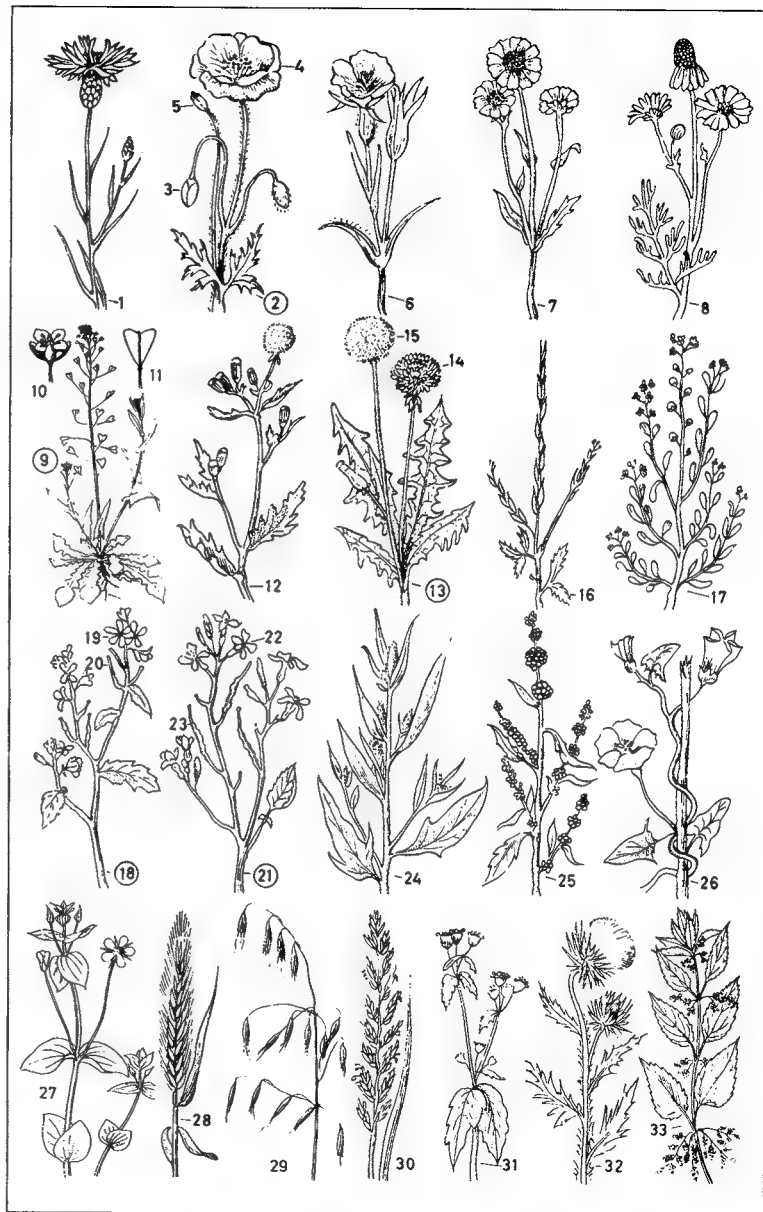

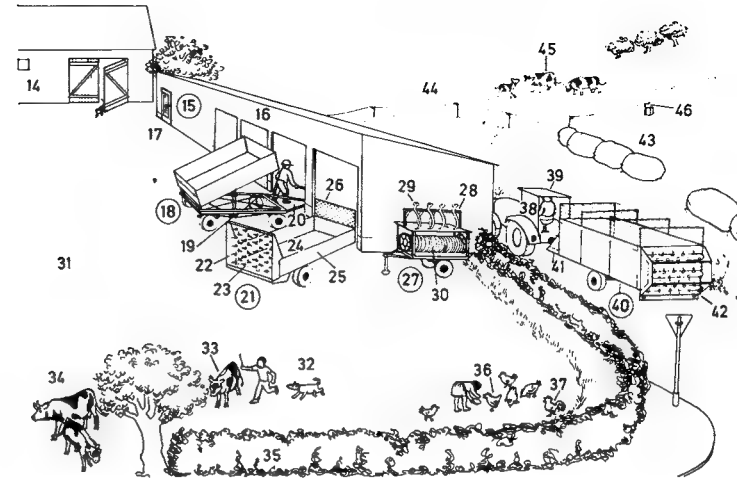
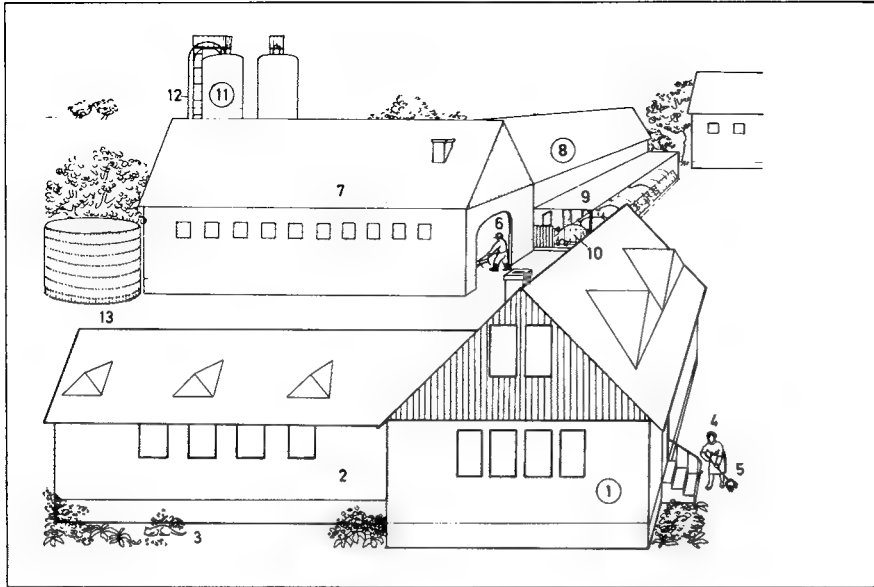

- 1 house
- 2 stable
- 3 house cat (cat)
- 4 farmer's wife
- 5 broom
- 6 farmer
- 7 cowshed
- 8 pigsty (sty, *Am.* pigpen, hogpen)
- 9 outdoor trough
- 10 pig
- 11 above-ground silo (fodder silo)
- 12 silo pipe (standpipe for filling the silo)
- 13 liquid manure silo
- 14 outhouse
- 15 machinery shed
- 16 sliding door
- 17 door to the workshop
- 18 three-way tip-cart, a transport vehicle
- 19 tipping cylinder
- 20 shafts

- 21 manure spreader (fertilizer spreader, manure distributor)
- 22 spreader unit (distributor unit)
- 23 spreader cylinder (distributor cylinder)
- 24 movable scraper floor
- 25 side planking (side board)
- 26 wire mesh front
- 27 sprinkler cart
- 28 sprinkler stand
- 29 sprinkler, a revolving sprinkler
- 30 sprinkler hoses
- 31 farmyard
- 32 watchdog
- 33 calf
- 34 dairy cow (milch-cow, milker)
- 35 farmyard hedge
- 36 chicken
- 37 cock (*Am.* rooster)
- 38 tractor
- 39 tractor driver
- 40 all-purpose trailer

- 41 [folded] pick-up attachment
- 42 unloading unit
- 43 polythene silo, a fodder silo
- 44 meadow
- 45 grazing cattle
- 46 electrified fence

1-41 work in the fields

- 1 fallow (fallow field, fallow ground)
- 2 boundary stone
- 3 boundary ridge, a balk (balk)
- 4 field
- 5 swingletree (*Am.* whiffletree, whippetree)
- 6 plough (*Am.* plow)
- 7 clod
- 8 furrow
- 9 stone

10-12 sowing

- 10 sower
- 11 seedlip
- 12 seed corn (seed)
- 13 field guard

- 14 chemical fertilizer (artificial fertilizer); *kinds*: potash fertilizer, phosphoric acid fertilizer, lime fertilizer, nitrogen fertilizer

- 15 cartload of manure (farmyard manure, dung)

- 16 oxteam (team of oxen, *Am.* span of oxen)

- 17 fields (farmland)

- 18 farm track (farm road)

19-30 hay harvest (haymaking)

- 19 rotary mower with swather (swath reaper)

- 20 connecting shaft (connecting rod)

- 21 power take-off (power take-off shaft)

- 22 meadow

- 23 swath (swathe)

- 24 tedder (rotary tedder)

- 25 teded hay

- 26 rotary swather

- 27 trailer with pick-up attachment

- 28 fence rack (rickstand), a drying rack for hay

- 29 rickstand, a drying rack for hay

- 30 hay tripod

31-41 grain harvest and seedbed preparation

- 31 combine harvester

- 32 cornfield

- 33 stubble field

- 34 bale of straw

- 35 straw baler (straw press), a high-pressure baler

- 36 swath (swathe) of straw (windrow of straw)

- 37 hydraulic bale loader

- 38 trailer

- 39 manure spreader

- 40 four-furrow plough (*Am.* plow)

- 41 combination seed-harrow

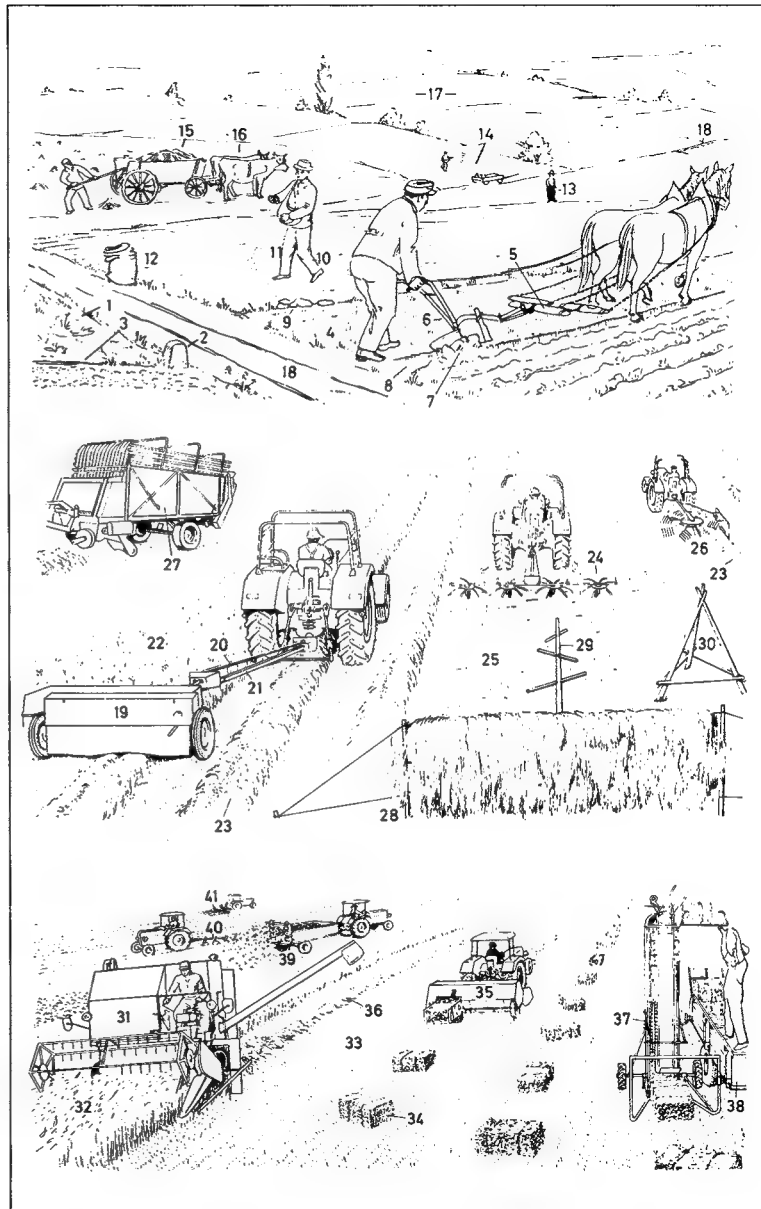

- 1-33 combine harvester (combine)**
 1 divider
 2 grain lifter
 3 cutter bar
 4 pick-up reel, a spring-tine reel
 5 reel gearing
 6 auger
 7 chain and slat elevator
 8 hydraulic cylinder for adjusting the cutting unit
 9 stone catcher (stone trap)
 10 awner
 11 concave
 12 threshing drum (drum)
 13 revolving beater [for freeing straw from the drum and preparing it for the shakers]
 14 straw shaker (strawwalker)
 15 fan for compressed-air winnowing
 16 preparation level
 17 louvred-type sieve
 18 sieve extension
 19 shoe sieve (reciprocating sieve)
 20 grain auger
 21 tailings auger
 22 tailings outlet
 23 grain tank
 24 grain tank auger
 25 augers feeding to the grain tank unloader
 26 grain unloader spout
 27 observation ports for checking tank contents
 28 six-cylinder diesel engine
 29 hydraulic pump with oil reservoir
 30 driving axle gearing
 31 driving wheel tyre (*Am.* tire)
 32 rubber-tyred (*Am.* rubber-tired) wheel on the steering axle
 33 driver's position
34-39 self-propelled forage harvester (self-propelled field chopper)
 34 cutting drum (chopper drum)
 35 corn head
 36 cab (driver's cab)
 37 swivel-mounted spout (discharge pipe)
 38 exhaust
 39 rear-wheel steering system
40-45 rotary swather
 40 cardan shaft
 41 running wheel
 42 double spring tine
 43 crank
 44 swath rake
 45 three-point linkage
46-58 rotary tedder
 46 tractor
 47 draw bar
 48 cardan shaft
 49 power take-off (power take-off shaft)
 50 gearing (gears)
 51 frame bar
 52 rotating head
 53 tine bar
 54 double spring tine
 55 guard rail
 56 running wheel
 57 height adjustment crank
 58 wheel adjustment
59-84 potato harvester
 59 control levers for the lifters of the digger and the hopper and for adjusting the shaft
 60 adjustable hitch
 61 drawbar
 62 drawbar support
 63 cardan shaft connection
 64 press roller
 65 gearing (gears) for the hydraulic system
 66 disc (disk) coulter (*Am.* colter) (rolling coulter)
 67 three-bladed share
 68 disc (disk) coulter (*Am.* colter) drive
 69 open-web elevator
 70 agitator
 71 multi-step reduction gearing
 72 feeder
 73 haulm stripper (flail rotor)
 74 rotary elevating drum
 75 mechanical tumbling separator
 76 haulm conveyor with flexible haulm strippers
 77 haulm conveyor agitator
 78 haulm conveyor drive with V-belt
 79 studded rubber belt for sorting vines, clods and stones
 80 trash conveyor
 81 sorting table
 82 rubber-disc (rubber-disc) rollers for presorting
 83 discharge conveyor
 84 endless-floor hopper
85-96 beet harvester
 85 topper
 86 feeler
 87 topping knife
 88 feeler support wheel with depth adjustment
 89 beet cleaner
 90 haulm elevator
 91 hydraulic pump
 92 compressed-air reservoir
 93 oil tank (oil reservoir)
 94 tensioning device for the beet elevator
 95 beet elevator belt
 96 beet hopper

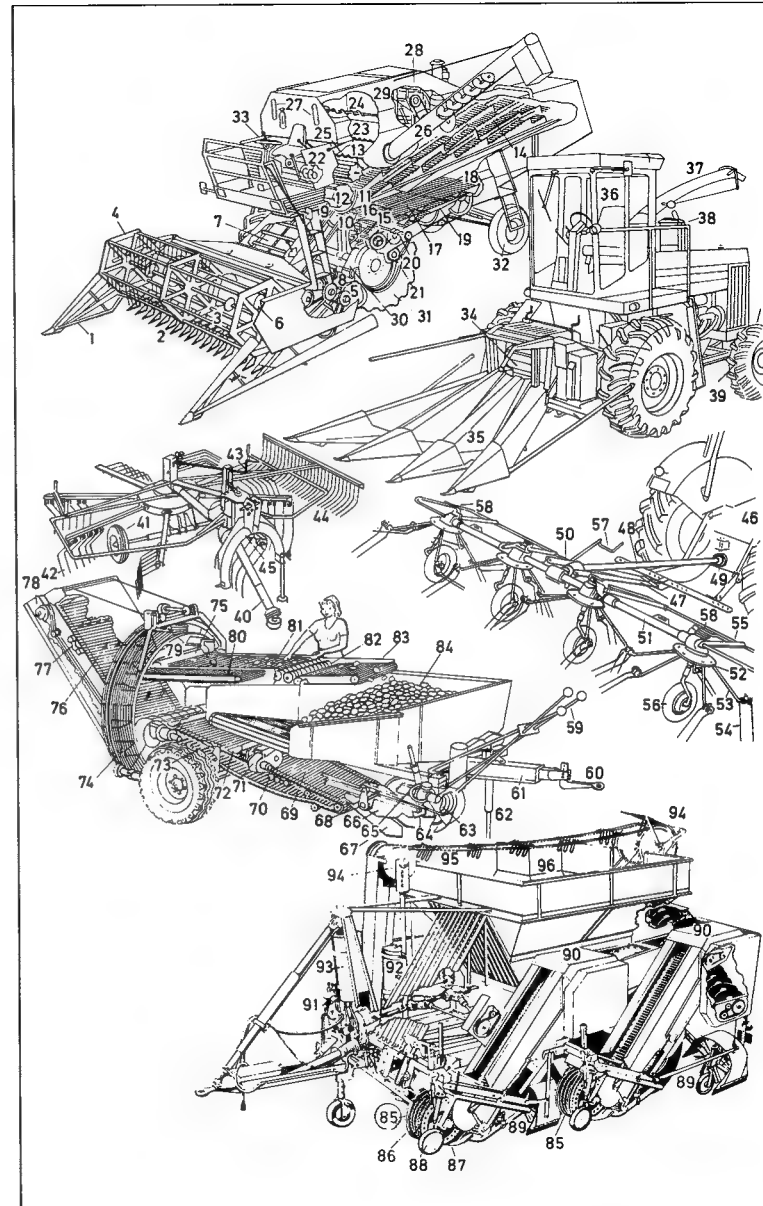

1 wheel plough (*Am. plow*), a single-bottom plough [*form.*]
 2 handle
 3 plough (*Am. plow*) stilt (plough handle)
 4-8 plough (*Am. plow*) bottom
 4 mouldboard (*Am. moldboard*)
 5 landside
 6 sole (slade)
 7 ploughshare (share, *Am. plowshare*)
 8 frog (frame)
 9 beam (plough beam, *Am. plowbeam*)
 10 knife coulter (*Am. colter*), a coulter
 11 skim coulter (*Am. colter*)
 12 guide-chain crossbar
 13 guide chain
 14-19 forecarriage
 14 adjustable yoke
 15 land wheel
 16 furrow wheel
 17 hake chain
 18 draught beam (drawbar)
 19 hake
 20 tractor (general-purpose tractor)
 21 cab frame (roll bar)
 22 seat
 23 power take-off gear-change (gearshift)
 24-29 power lift
 24 ram piston
 25 lifting rod adjustment
 26 drawbar frame
 27 top link
 28 lower link
 29 lifting rod
 30 drawbar coupling
 31 live power take-off (live power take-off shaft, take-off shaft)
 32 differential gear (differential)
 33 floating axle
 34 torque converter lever
 35 gear-change (gearshift)
 36 multi-speed transmission
 37 fluid clutch (fluid drive)
 38 power take-off gear
 39 main clutch
 40 power take-off gear-change (gearshift) with power take-off clutch
 41 hydraulic power steering and reversing gears
 42 fuel tank
 43 float lever
 44 four-cylinder diesel engine
 45 oil sump and pump for the pressure-feed lubrication system

46 fresh oil tank
 47 track rod (*Am. tie rod*)
 48 front axle pivot pin
 49 front axle suspension
 50 front coupling (front hitch)
 51 radiator
 52 fan
 53 battery
 54 oil bath air cleaner (oil bath air filter)
 55 cultivator (grubber)
 56 sectional frame
 57 spring line
 58 share, a diamond-shaped share (*sim.*: chisel-shaped share)
 59 depth wheel
 60 depth adjustment
 61 coupling (hitch)
 62 reversible plough (*Am. plow*), a mounted plough
 63 depth wheel
 64-67 plough (*Am. plow*) bottom, a general-purpose plough bottom
 64 mouldboard (*Am. moldboard*)
 65 ploughshare (share, *Am. plowshare*), a pointed share
 66 sole (slade)
 67 landside
 68 skim coulter (*Am. colter*)
 69 disc (disk) coulter (*Am. colter*) (rolling coulter)
 70 plough (*Am. plow*) frame
 71 beam (plough beam, *Am. plowbeam*)
 72 three-point linkage
 73 swivel mechanism
 74 drill
 75 seed hopper
 76 drill coulter (*Am. colter*)
 77 delivery tube, a telescopic tube
 78 feed mechanism
 79 gearbox
 80 drive wheel
 81 track indicator
 82 disc (disk) harrow, a semimounted implement
 83 discs (disks) in X-configuration
 84 plain disc (disk)
 85 serrated-edge disc (disk)
 86 quick hitch
 87 combination seed-harrow
 88 three-section spike-tooth harrow
 89 three-section rotary harrow
 90 frame

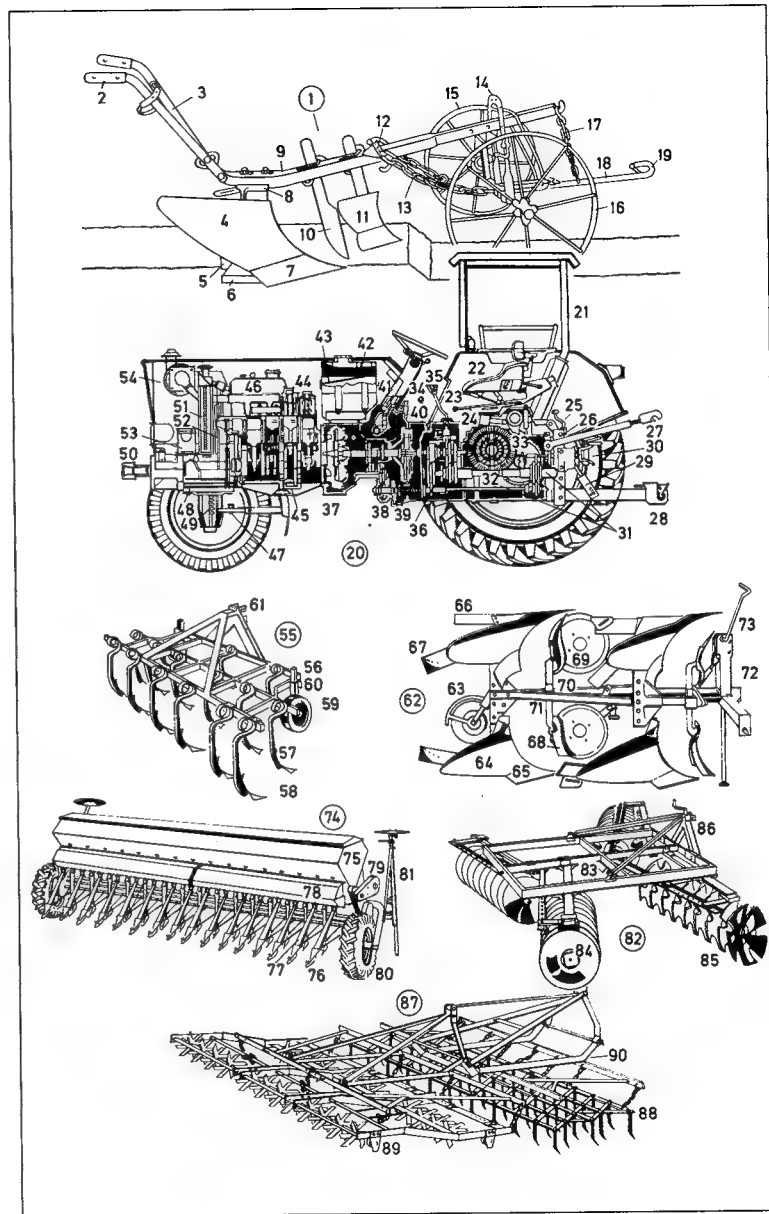

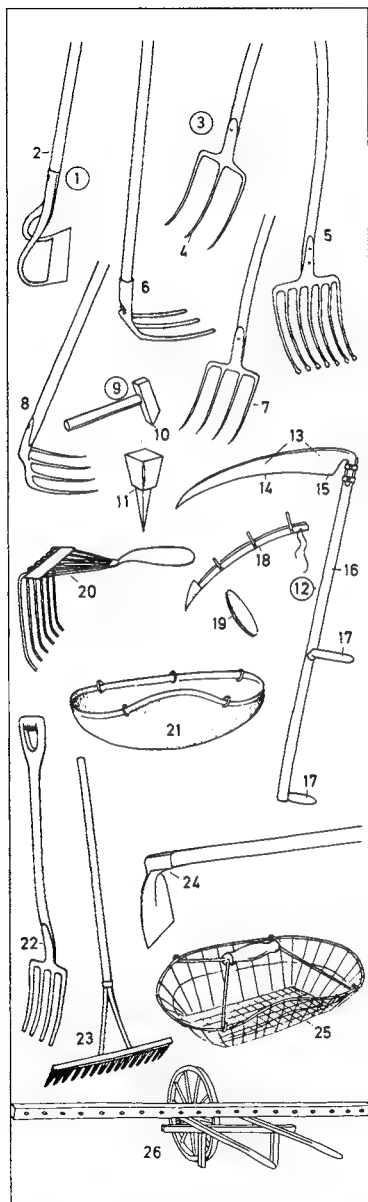

- 1 draw hoe (garden hoe)
- 2 hoe handle
- 3 three-pronged (three-tined) hay fork (fork)
- 4 prong (tine)
- 5 potato fork
- 6 potato hook
- 7 four-pronged (four-tined) manure fork (fork)
- 8 manure hoe
- 9 whetting hammer [for scythes]
- 10 peen (pane)
- 11 whetting anvil [for scythes]
- 12 scythe
- 13 scythe blade
- 14 cutting edge
- 15 heel
- 16 snath (snathe, snead, sneath)
- 17 handle
- 18 scythe sheath
- 19 whetstone (scythestone)
- 20 potato rake
- 21 potato planter
- 22 digging fork (fork)
- 23 wooden rake (rake, hayrake)
- 24 hoe (potato hoe)
- 25 potato basket, a wire basket
- 26 clover broadcaster

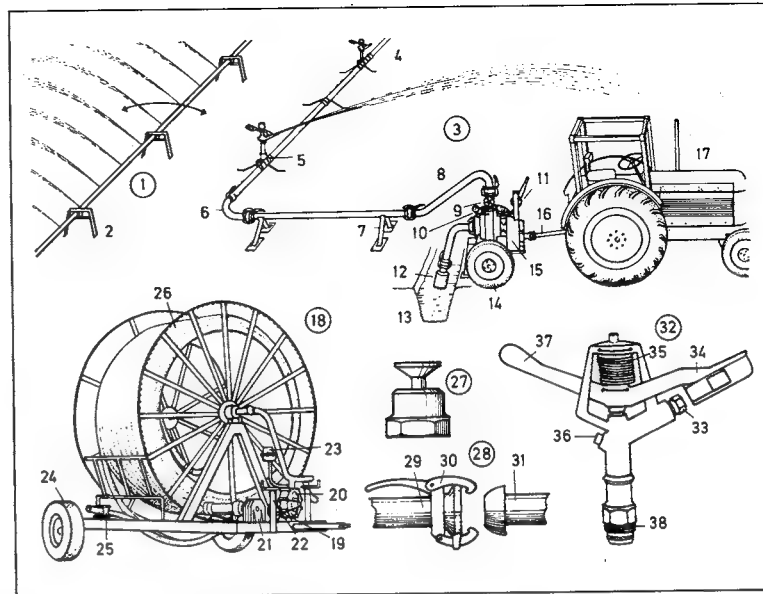

- | | |
|---|--|
| 1 oscillating spray line | 20 turbine |
| 2 stand (steel chair) | 21 gearing (gears) |
| 3 portable irrigation system | 22 adjustable support |
| 4 revolving sprinkler | 23 centrifugal evacuating pump |
| 5 standpipe coupler | 24 wheel |
| 6 elbow with cardan joint (cardan coupling) | 25 pipe support |
| 7 pipe support (trestle) | 26 polyester pipe |
| 8 pump connection | 27 sprinkler nozzle |
| 9 delivery valve | 28 quick-fitting pipe connection with cardan joint |
| 10 pressure gauge (<i>Am. gage</i>) (manometer) | 29 M-cardan |
| 11 centrifugal evacuating pump | 30 clamp |
| 12 basket strainer | 31 V-cardan |
| 13 channel | 32 revolving sprinkler, a field sprinkler |
| 14 chassis of the p.t.o.-driven pump (power take-off-driven pump) | 33 nozzle |
| 15 p.t.o.-driven (power take-off-driven) pump | 34 breaker |
| 16 cardan shaft | 35 breaker spring |
| 17 tractor | 36 stopper |
| 18 long-range irrigation unit | 37 counterweight |
| 19 drive connection | 38 thread |

1-47 arable crops (agricultural produce, farm produce)

1-37 varieties of grain (grain, cereals, farinaceous plants, bread-corn)

1 rye (*also*: corn, 'corn' often meaning the main cereal of a country or region; in Northern Germany: rye; in Southern Germany and Italy: wheat; in Sweden: barley; in Scotland: oats; in North America: maize; in China: rice)

2 ear of rye, a spike (head)

3 spikelet

4 ergot, a grain deformed by fungus [shown with mycelium]

5 corn stem after tillering

6 culm (stalk)

7 node of the culm

8 leaf (grain leaf)

9 leaf sheath (sheath)

10 spikelet

11 glume

12 awn (beard, arista)

13 seed (grain, kernel, farinaceous grain)

14 embryo plant

15 seed

16 embryo

17 root

18 root hair

19 grain leaf

20 leaf blade (blade, lamina)

21 leaf sheath

22 ligule (ligula)

23 wheat

24 spelt

25 seed; *unripe*: green spelt, a soup vegetable

26 barley

27 oat panicle, a panicle

28 millet

29 rice

30 rice grain

31 maize (Indian corn, *Am. corn*);

varieties: popcorn, dent corn, flint corn (flint maize, *Am. Yankee corn*), pod corn (*Am. cow corn*, husk corn), soft corn (*Am. flour corn*, squaw corn), sweet corn

32 female inflorescence

33 husk (shuck)

34 style

35 male inflorescence (tassel)

36 maize cob (*Am. corn cob*)

37 maize kernel (grain of maize)

38-45 root crops

38 potato plant (potato), a tuberous plant; *varieties*: round, round-oval (pear-shaped), flat-oval, long, kidney-shaped potato; *according to colour*: white (*Am. Irish*), yellow, red, purple potato

39 seed potato (seed tuber)

40 potato tuber (potato, tuber)

41 potato top (potato haulm)

42 flower

43 poisonous potato berry (potato apple)

44 sugar beet, a beet

45 root (beet)

46 beet top

47 beet leaf

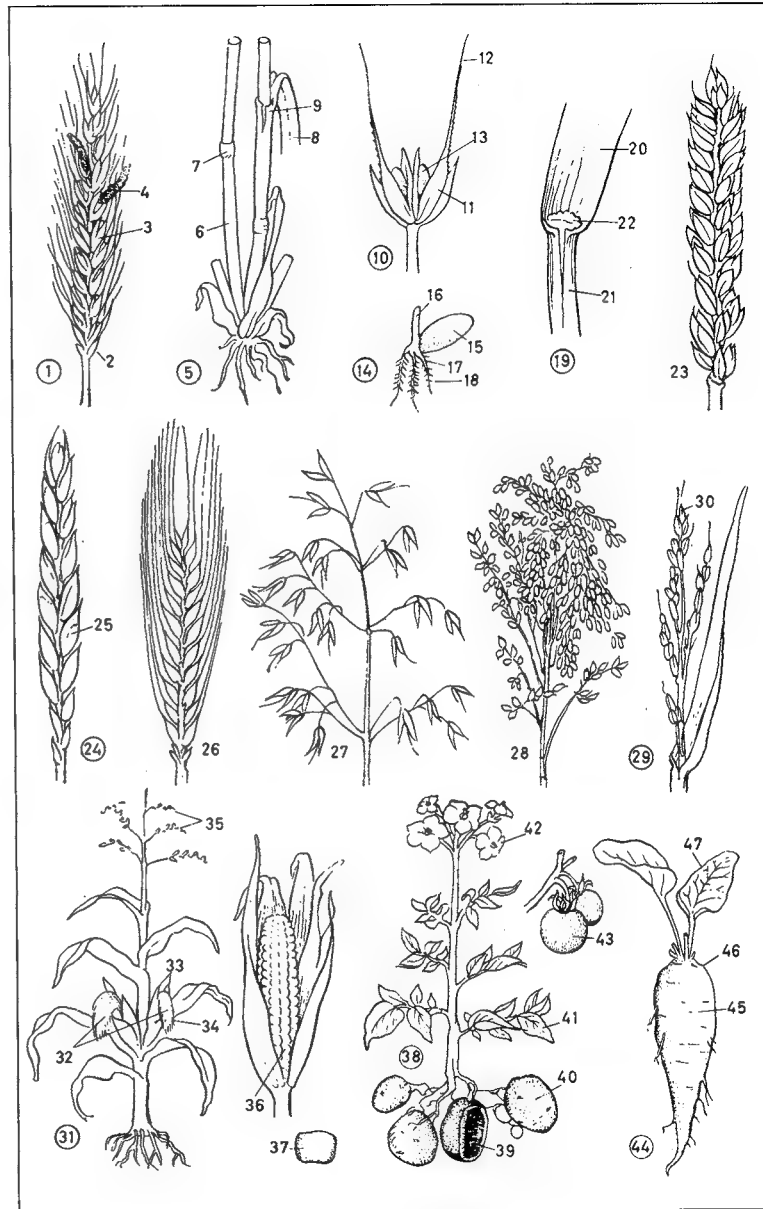

1-28 fodder plants (forage plants) for tillage

- 1 red clover (purple clover)
- 2 white clover (Dutch clover)
- 3 alsike clover (alsike)
- 4 crimson clover
- 5 four-leaf (four-leaved) clover
- 6 kidney vetch (lady's finger, lady-finger)
- 7 flower
- 8 pod
- 9 lucerne (lucerne, purple medick)
- 10 sainfoin (cock's head, cockshead)
- 11 bird's foot (bird-foot, bird's foot trefoil)
- 12 corn spurrey (spurrey, spurry), a spurrey (spurry)
- 13 common comfrey, one of the borage family (Boraginaceae)
- 14 flower (blossom)
- 15 field bean (broad bean, tick bean, horse bean)
- 16 pod
- 17 yellow lupin
- 18 common vetch
- 19 chick-pea
- 20 sunflower
- 21 mangold (mangelwurzel, mangold-wurzel, field mangel)
- 22 false oat (oat-grass)
- 23 spikelet
- 24 meadow fescue grass, a fescue
- 25 cock's foot (cocksfoot)
- 26 Italian ryegrass; *sim.*: perennial ryegrass (English ryegrass)
- 27 meadow foxtail, a paniculate grass
- 28 greater burnet saxifrage

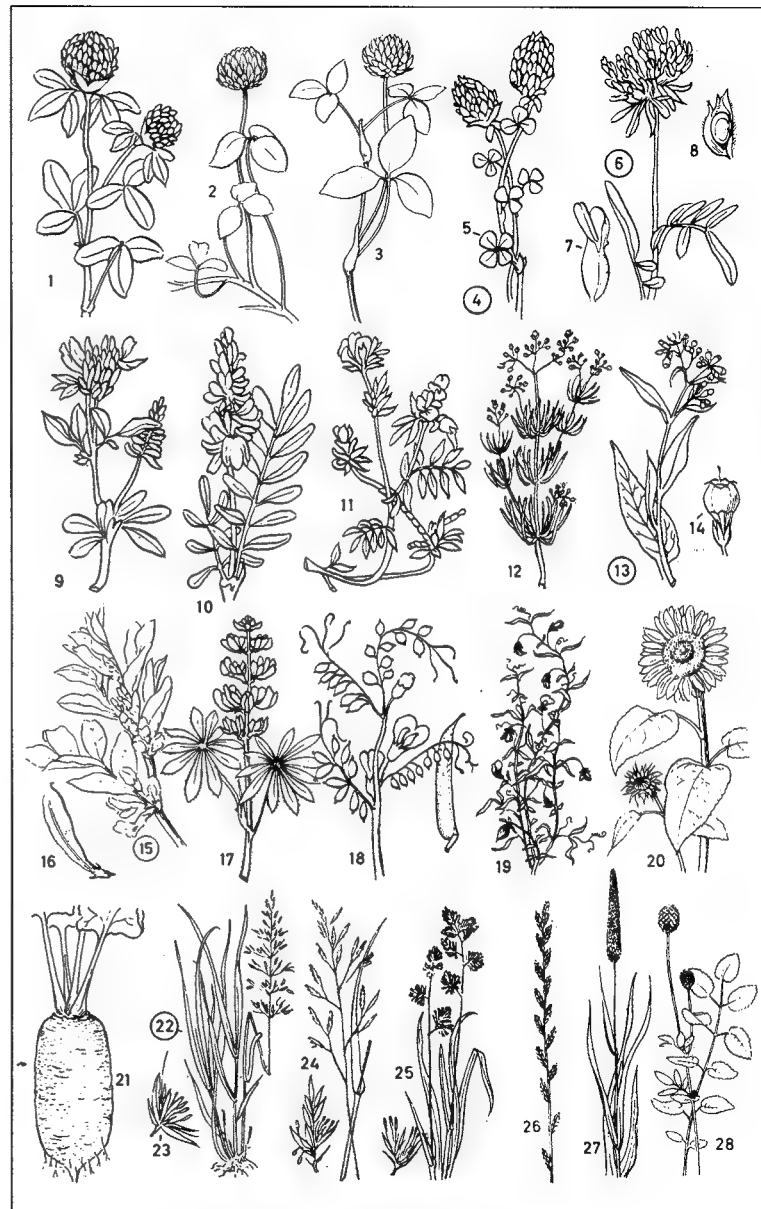

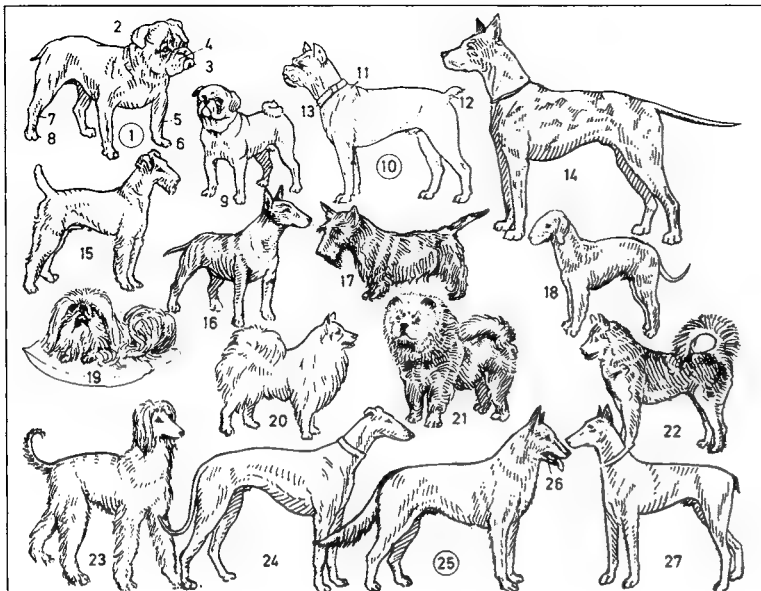
**1-14 mastiffs**

- 1 bulldog
- 2 ear, a rose-ear
- 3 muzzle
- 4 nose
- 5 foreleg
- 6 forepaw
- 7 hind leg
- 8 hind paw
- 9 pug (pug dog)
- 10 boxer
- 11 withers
- 12 tail, a docked tail
- 13 collar
- 14 Great Dane
- 15-18 terriers**
- 15 wire-haired fox terrier
- 16 bull terrier
- 17 Scotch terrier (Scottish terrier)
- 18 Bedlington terrier
- 19 Pekinese (Pekingese, Pekinese dog, Pekingese dog)
- 20-22 spitzes**

20 spitz (Pomeranian)

- 21 chow (chow-chow)
- 22 husky
- 23, 24 greyhounds (Am. grayhounds)**
- 23 Afghan (Afghan hound)
- 24 greyhound (Am. grayhound), a courser
- 25 Alsatian (German sheepdog, Am. German shepherd), a police dog, watch dog, and guide dog
- 26 flews (chaps)
- 27 Dobermann terrier

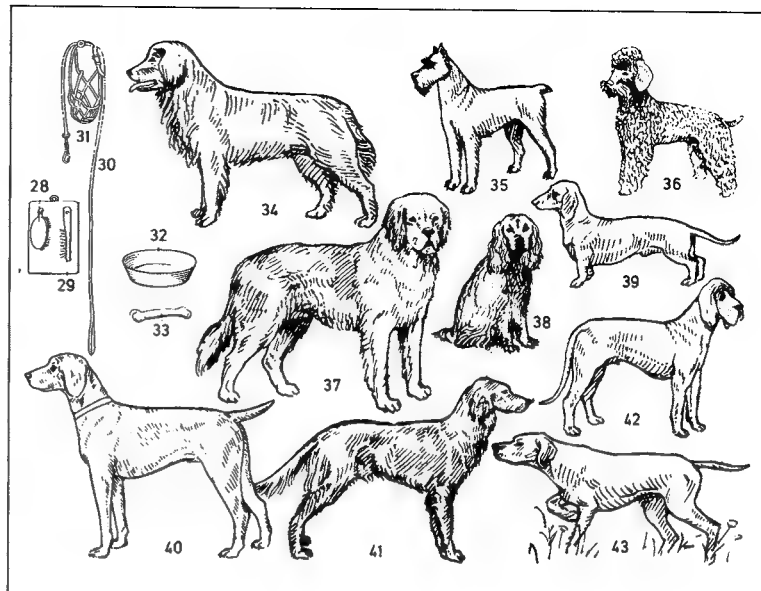
**28 dog brush**

- 29 dog comb
- 30 lead (dog lead, leash); *for hunting:* leash
- 31 muzzle
- 32 feeding bowl (dog bowl)
- 33 bone
- 34 Newfoundland dog
- 35 schnauzer
- 36 poodle; *sim. and smaller:* pygmy (pigmy) poodle
- 37 St. Bernard (St. Bernard dog)
- 38-43 hunting dogs**
- 38 cocker spaniel
- 39 dachshund, a terrier
- 40 German pointer
- 41 English setter
- 42 trackhound
- 43 pointer, a trackhound

1-6 equitation (high school riding, haute école)

- 1 piaffe
2 walk
3 passage
4 levade (pesade)
5 capriole
6 courbette (curvet)

7-25 harness

- 7-13, 25 bridle
7-11 headstall (headpiece, halter)

- 7 noseband
8 cheek piece (cheek strap)
9 browband (front band)

- 10 crownpiece
11 throatlatch (throatlash)

- 12 curb chain
13 curb bit
14 hasp (hook) of the hame (*Am.* drag hook)

- 15 pointed collar, a collar
16 trappings (side trappings)

- 17 saddle-pad
18 girth

- 19 backband
20 shaft chain (pole chain)

- 21 pole
22 trace

- 23 second girth (emergency girth)
24 trace

- 25 reins (*Am.* lines)

- 26-36 breast harness**
26 blinker (*Am.* blinder, winker)

- 27 breast collar ring
28 breast collar (Dutch collar)

- 29 fork
30 neck strap

- 31 saddle-pad
32 loin strap

- 33 reins (rein, *Am.* line)
34 crupper (crupper-strap)

- 35 trace
36 girth (belly-band)

- 37-49 saddles**
37-44 stock saddle (*Am.* western saddle)

- 37 saddle seat

38 pommel horn (horn)

39 cantle

40 flap (*Am.* fender)

41 bar

42 stirrup leather

43 stirrup (stirrup iron)

44 blanket

45-49 English saddle (cavalry saddle)

45 seat

46 cantle

47 flap

48 roll (knee roll)

49 pad

50, 51 spurs

50 box spur (screwed jack spur)

51 strapped jack spur

52 curb bit

53 gag bit (gag)

54 currycomb

55 horse brush (body brush, dandy brush)

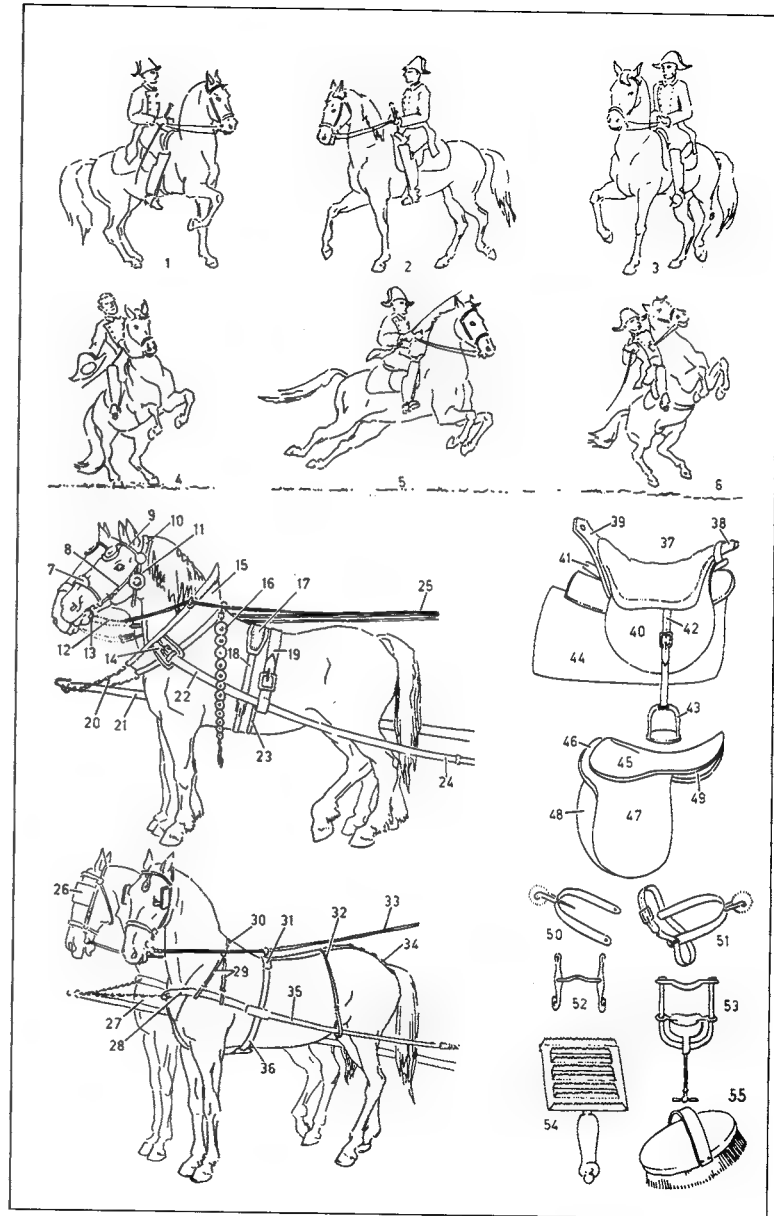

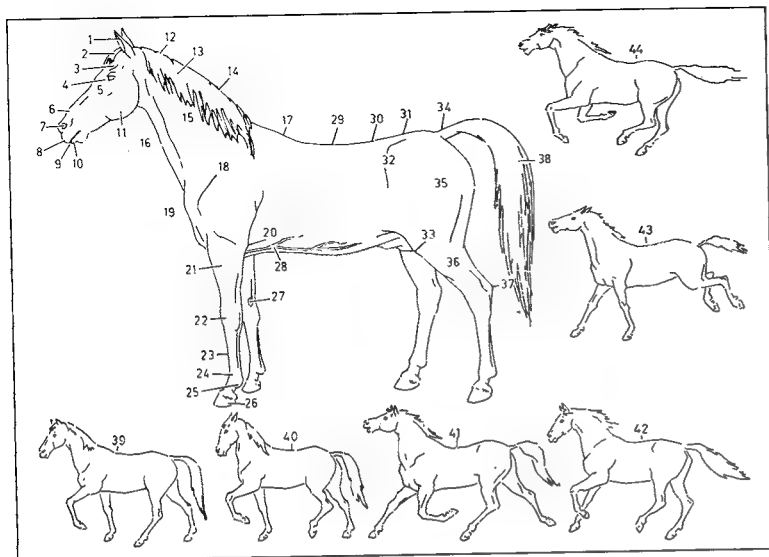
**1-38 points of the horse****1-11 head (horse's head)**

- 1 ear
- 2 forelock
- 3 forehead
- 4 eye
- 5 face
- 6 nose
- 7 nostril
- 8 upper lip
- 9 mouth
- 10 underlip (lower lip)
- 11 lower jaw
- 12 crest (neck)
- 13 mane (horse's mane)
- 14 crest (horse's crest)
- 15 neck
- 16 throat (*Am.* throatlatch, throatlash)
- 17 withers
- 18-27 forehand**
- 18 shoulder
- 19 breast
- 20 elbow
- 21 forearm
- 22-26 forefoot**
- 22 knee (carpus, wrist)

- 23 cannon
- 24 fetlock
- 25 pastern
- 26 hoof
- 27 chestnut (castor), a callosity
- 28 spur vein
- 29 back
- 30 loins (lumbar region)
- 31 croup (rump, crupper)
- 32 hip
- 33-37 hind leg**
- 33 stifle (stifle joint)
- 34 root (dock) of the tail
- 35 haunch
- 36 gaskin
- 37 hock
- 38 tail
- 39-44 gaits of the horse**
- 39 walk
- 40 pace
- 41 trot
- 42 canter (hand gallop)
- 43, 44 full gallop
- 43 full gallop at the moment of descent on to the two forefeet
- 44 full gallop at the moment when all four feet are off the ground

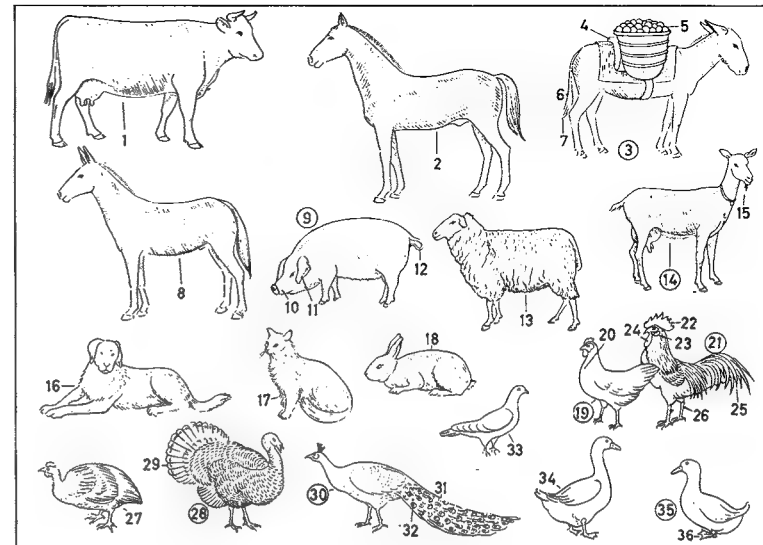
**Abbreviations:**

m. = male; *c.* = castrated;

f. = female; *y.* = young

1-8 cattle and horses

- 1 cow, a ruminant; *m.* bull; *c.* ox; *f.* cow; *y.* calf
- 2 horse; *m.* stallion; *c.* gelding; *f.* mare; *y.* foal
- 3 donkey
- 4 pack saddle (carrying saddle)
- 5 pack (load)
- 6 tufted tail
- 7 tuft
- 8 mule, a cross between a male donkey and a mare
- 9 pig, a cloven-hoofed animal; *m.* boar; *f.* sow; *y.* piglet
- 10 pig's snout (snout)
- 11 pig's ear
- 12 curly tail
- 13 sheep; *m.* ram; *c.* wether; *f.* ewe; *y.* lamb
- 14 goat
- 15 goat's beard
- 16 dog, a Leonberger; *m.* dog; *f.* bitch; *y.* pup (puppy, whelp)

- 17 cat, an Angora cat (Persian cat); *m.* tom (tom cat)

18-36 small domestic animals

- 18 rabbit; *m.* buck; *f.* doe
- 19-36 poultry (domestic fowl)**
- 19-26 chicken**
- 19 hen
- 20 crop (craw)
- 21 cock (*Am.* rooster); *c.* capon
- 22 cockscomb (comb, crest)
- 23 lap
- 24 wattle (gill, dewlap)
- 25 falcate (falcated) tail
- 26 spur
- 27 guinea fowl
- 28 turkey; *m.* turkey cock (gobbler); *f.* turkey hen
- 29 fan tail
- 30 peacock
- 31 peacock's feather
- 32 eye (ocellus)
- 33 pigeon; *m.* cock pigeon
- 34 goose; *m.* gander; *y.* gosling
- 35 duck; *m.* drake; *y.* duckling
- 36 web (palmations) of webbed foot (palmate foot)

- 1-27 poultry farming (intensive poultry management)
 1-17 straw yard (strawed yard) system
 1 fold unit for growing stock (chick unit)
 2 chick
 3 brooder (hover)
 4 adjustable feeding trough
 5 pullet fold unit
 6 drinking trough
 7 water pipe
 8 litter
 9 pullet
 10 ventilator
 11-17 broiler rearing (rearing of broiler chickens)
 11 chicken run (*Am. fowl run*)
 12 broiler chicken (broiler)
 13 mechanical feeder (self-feeder, feed dispenser)
 14 chain
 15 feed supply pipe
 16 mechanical drinking bowl (mechanical drinker)
 17 ventilator
 18 battery system (cage system)
 19 battery (laying battery)
 20 tiered cage (battery cage, stepped cage)
 21 feeding trough
 22 egg collection by conveyor
 23-27 mechanical feeding and dunging (manure removal, droppings removal)
 23 rapid feeding system for battery feeding (mechanical feeder)
 24 feed hopper
 25 endless-chain feed conveyor (chain feeder)
 26 water pipe (liquid feed pipe)
 27 dunging chain (dunging conveyor)
 28 setting and hatching machine
 29 ventilation drum [for the setting compartment]
 30 hatching compartment (hatcher)
 31 metal trolley for hatching trays

- 32 hatching tray
 33 ventilation drum motor
 34-53 egg productions
 34 egg collection system (egg collection)
 35 multi-tier transport
 36 collection by pivoted fingers
 37 drive motor
 38 sorting machine
 39 conveyor trolley
 40 fluorescent screen
 41 suction apparatus (suction box) for transporting eggs
 42 shelf for empty and full egg boxes
 43 egg weighers
 44 grading
 45 egg box
 46 fully automatic egg-packing machine
 47 radioscope box
 48 radioscope table
 49-51 feeder
 49 suction transporter
 50 vacuum line
 51 supply table
 52 automatic counting and grading
 53 packing box dispenser
 54 leg ring
 55 wing tally (identification tally)
 56 bantam
 57 laying hen
 58 hen's egg (egg)
 59 eggshell, an egg integument
 60 shell membrane
 61 air space
 62 white [of the egg] (albumen)
 63 chalaza (*Am. treadle*)
 64 vitelline membrane (yolk sac)
 65 blastodisc (germinal disc, cock's tread, cock's treadle)
 66 germinal vesicle
 67 white
 68 yolk

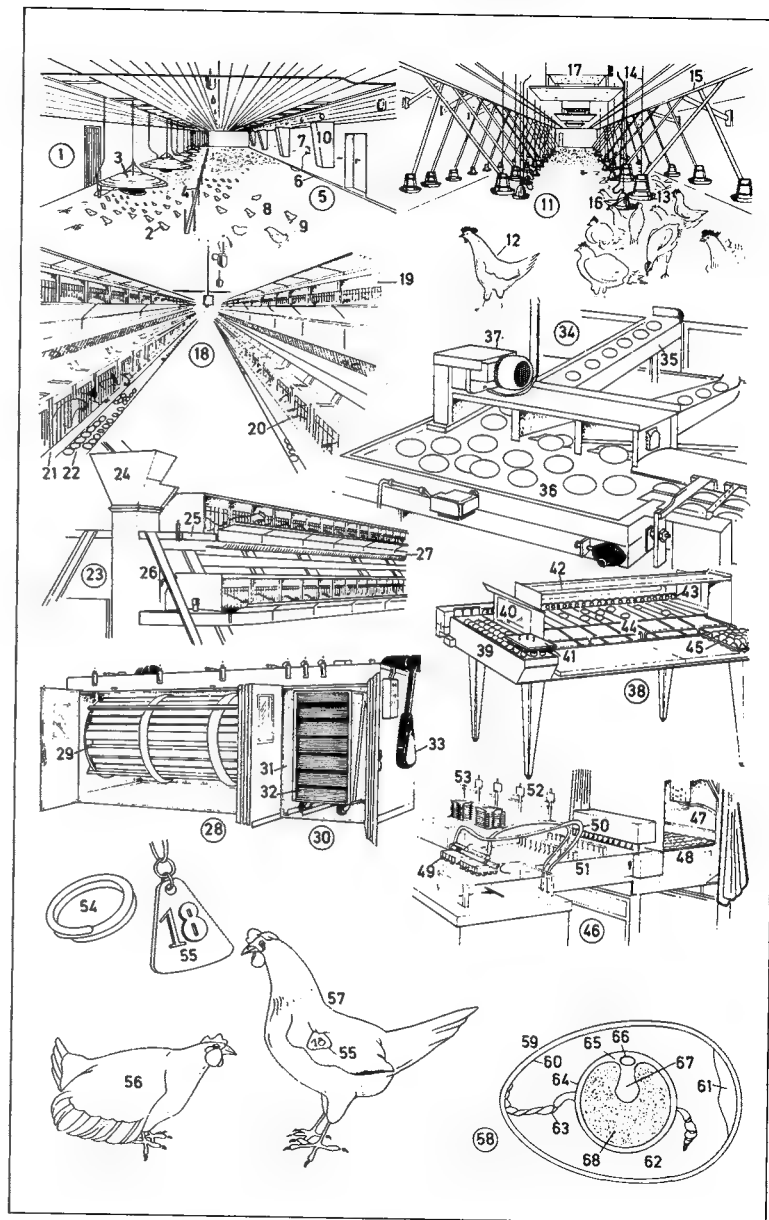

- 1 stable
- 2 horse stall (stall, horse box, box)
- 3 feeding passage
- 4 pony
- 5 bars
- 6 litter
- 7 bale of straw
- 8 ceiling light
- 9 sheep pen
- 10 mother sheep (ewe)
- 11 lamb
- 12 double hay rack
- 13 hay
- 14 dairy cow shed
- 15-16 tether
- 15 chain
- 16 rail
- 17 dairy cow (milch-cow, milker)
- 18 udder
- 19 teat
- 20 manure gutter
- 21 manure removal by sliding bars
- 22 short standing
- 23 milking parlour (Am. parlor), a herringbone parlour
- 24 working passage
- 25 milker (Am. milkman)
- 26 teat cup cluster
- 27 milk pipe
- 28 air line
- 29 vacuum line
- 30 teat cup
- 31 window
- 32 pulsator
- 33 release phase
- 34 squeeze phase
- 35 pigsty (Am. pigpen, hogpen)
- 36 pen for young pigs
- 37 feeding trough
- 38 partition
- 39 pig, a young pig
- 40 farrowing and store pen
- 41 sow
- 42 piglets (Am. shoats, shotes) (sucking pigs [for first 8 weeks])
- 43 farrowing rails
- 44 liquid manure channel

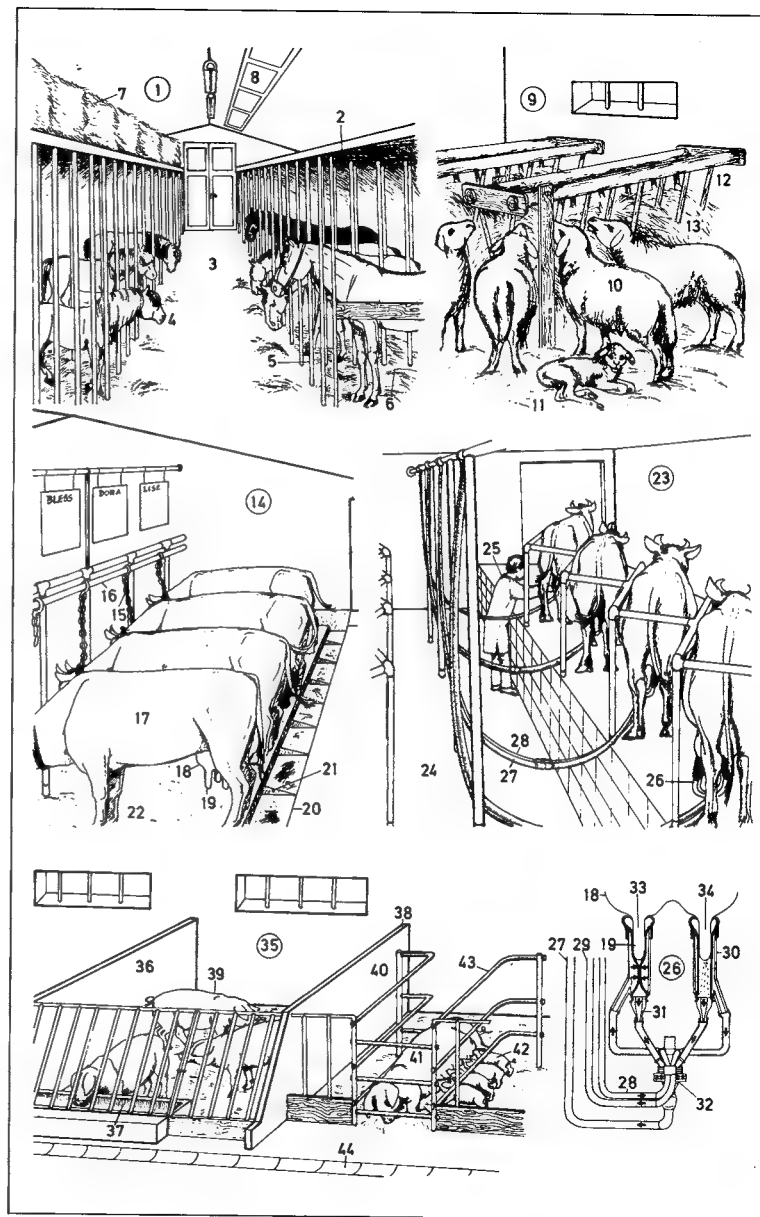

- 1-48 dairy (dairy plant)
1 milk reception
 2 milk tanker
 3 raw milk pump
 4 flowmeter, an oval (elliptical) gear meter
 5 raw milk storage tank
 6 gauge (*Am. gage*)
 7 **central control room**
 8 chart of the dairy
 9 flow chart (flow diagram)
 10 storage tank gauges (*Am. gages*)
 11 control panel
12-48 milk processing area
 12 sterilizer (homogenizer)
 13 milk heater; *sim.*: cream heater
 14 cream separator
 15 fresh milk tanks
 16 tank for sterilized milk
 17 skim milk (skimmed milk) tank
 18 buttermilk tank
 19 cream tank
 20 fresh milk filling and packing plant
 21 filling machine for milk cartons; *sim.*: milk tub filler
 22 milk carton
 23 conveyor belt (conveyor)
 24 shrink-sealing machine
 25 pack of twelve in shrink foil
 26 ten-litre filling machine
 27 heat-sealing machine
 28 plastic sheets
 29 heat-sealed bag
 30 crate
 31 cream maturing vat
 32 butter shaping and packing machine
 33 butter churn, a creamery butter machine for continuous butter making
 34 butter supply pipe
 35 shaping machine
 36 packing machine
 37 branded butter in 250 g packets
 38 plant for producing curd cheese (curd cheese machine)
 39 curd cheese pump

- 40 cream supply pump
 41 curds separator
 42 sour milk vat
 43 stirrer
 44 curd cheese packing machine
 45 packeted curd cheese
 46 bottle-capping machine (capper)
 47 cheese machine
 48 rennet vat

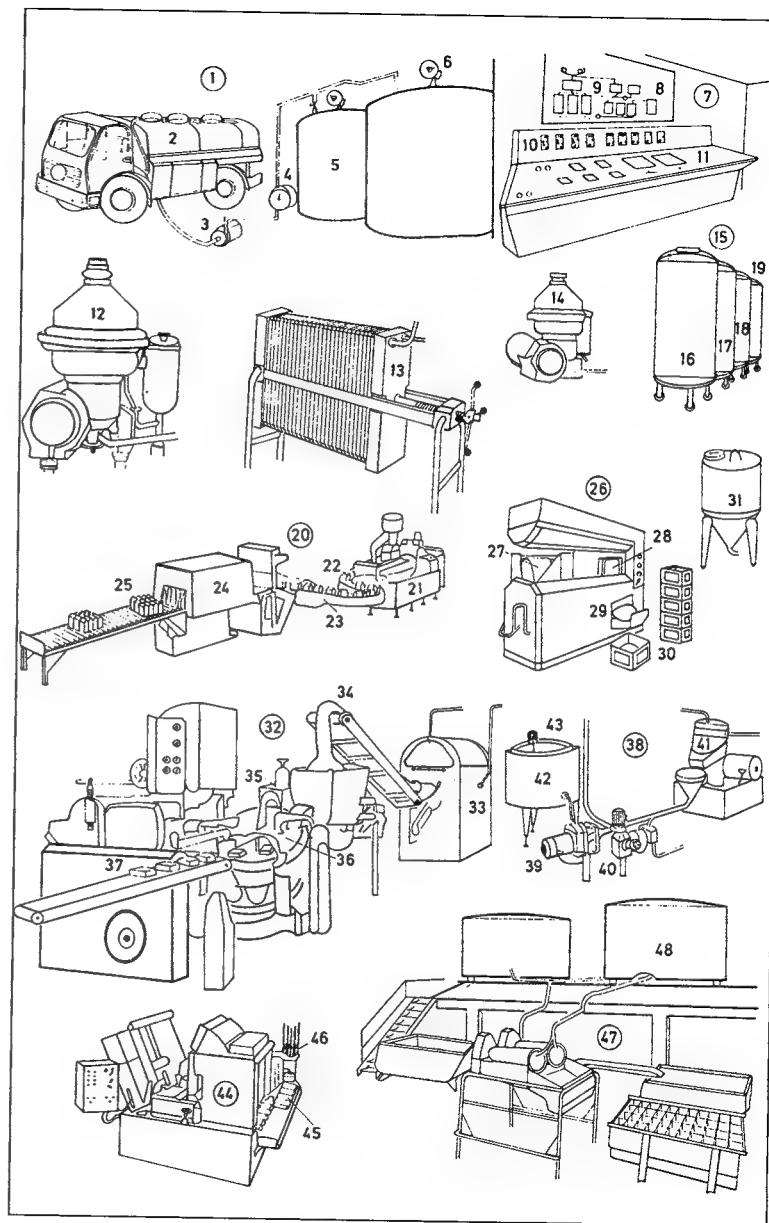

- 1-25 bee (honey-bee, hive-bee)
1, 4-5 castes (social classes) of bees
 1 worker (worker bee)
 2 three simple eyes (ocelli)
 3 load of pollen on the hind leg
 4 queen (queen bee)
 5 drone (male bee)
6-9 left hind leg of a worker
 6 pollen basket
 7 pollen comb (brush)
 8 double claw
 9 suction pad
10-19 abdomen of the worker
10-14 stinging organs
 10 barb
 11 sting
 12 sting sheath
 13 poison sac
 14 poison gland
15-19 stomachic-intestinal canal
 15 intestine
 16 stomach
 17 contractile muscle
 18 honey bag (honey sac)
 19 oesophagus (esophagus, gullet)
20-24 compound eye
 20 facet
 21 crystal cone
 22 light-sensitive section
 23 fibre (*Am.* fiber) of the optic nerve
 24 optic nerve
 25 wax scale
26-30 cell
 26 egg
 27 cell with the egg in it
 28 young larva
 29 larva (grub)
 30 chrysalis (pupa)
31-43 honeycomb
 31 brood cell
 32 sealed (capped) cell with chrysalis (pupa)
 33 sealed (capped) cell with honey (honey cell)
 34 worker cells
 35 storage cells, with pollen
 36 drone cells

- 37 queen cell
 38 queen emerging from her cell
 39 cap (capping)
 40 frame
 41 distance piece
 42 [artificial] honeycomb
 43 septum (foundation, comb foundation)
 44 queen's travelling (*Am.* traveling) box
45-50 beehive, a frame hive (movable-frame hive, movable-comb hive)
 45 super (honey super) with honeycombs
 46 brood chamber with breeding combs
 47 queen-excluder
 48 entrance
 49 flight board (alighting board)
 50 window
 51 old-fashioned bee shed
 52 straw hive (*skep*), a hive
 53 swarm (swarm cluster) of bees
 54 swarming net (bag net)
 55 hooked pole
 56 apiary (bee house)
 57 beekeeper (*apiarist, Am. beeman*)
 58 bee veil
 59 bee smoker
 60 natural honeycomb
 61 honey extractor (honey separator)
 62-63 strained honey (honey)
 62 honey pail
 63 honey jar
 64 honey in the comb
 65 wax taper
 66 wax candle
 67 beeswax
 68 bee sting ointment

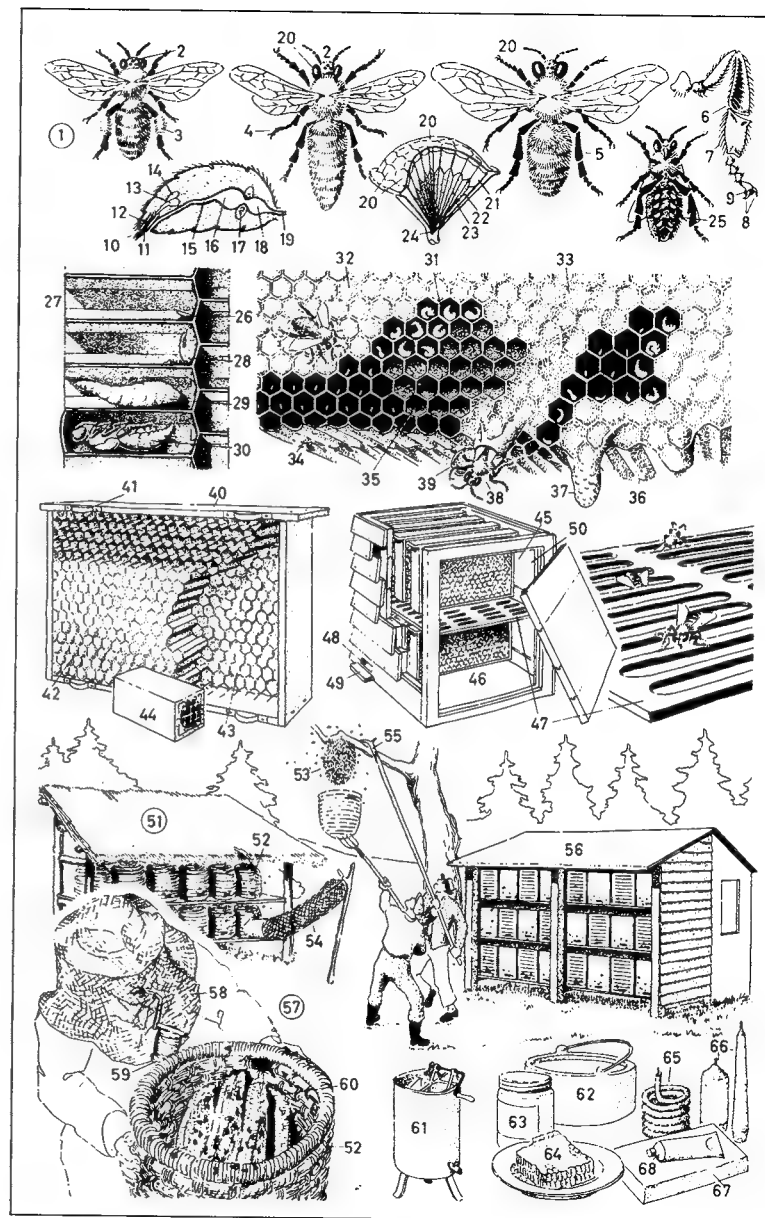

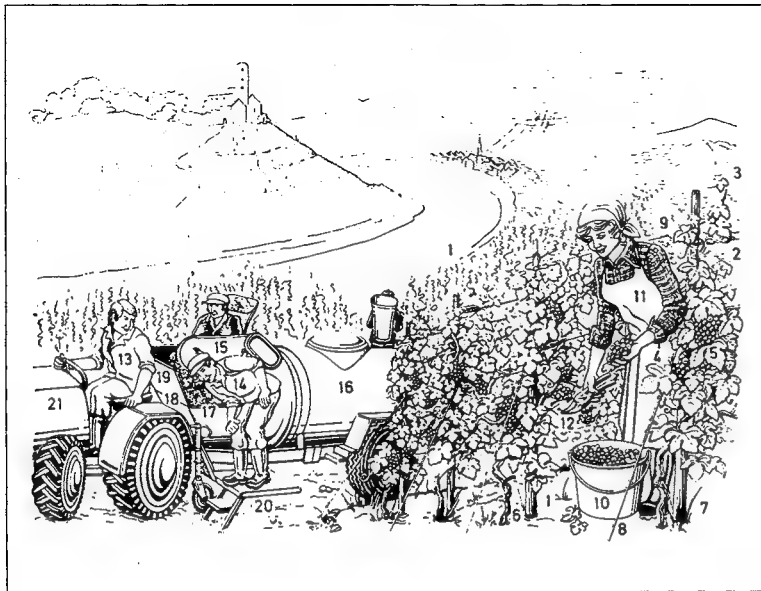
**1-21 vineyard area**

- 1 vineyard using wire trellises for training vines
- 2-9 vine (*Am.* grapevine)
- 2 vine shoot
- 3 long shoot
- 4 vine leaf
- 5 bunch of grapes (cluster of grapes)
- 6 vine stem
- 7 post (stake)
- 8 guy (guy wire)
- 9 wire trellis
- 10 tub for grape gathering
- 11 grape gatherer
- 12 secateurs for pruning vines
- 13 wine grower (viniculturist, viticulturist)
- 14 dosser carrier
- 15 dosser (pannier)
- 16 crushed grape transporter
- 17 grape crusher
- 18 hopper
- 19 three-sided flap extension
- 20 platform
- 21 vineyard tractor, a narrow-track tractor

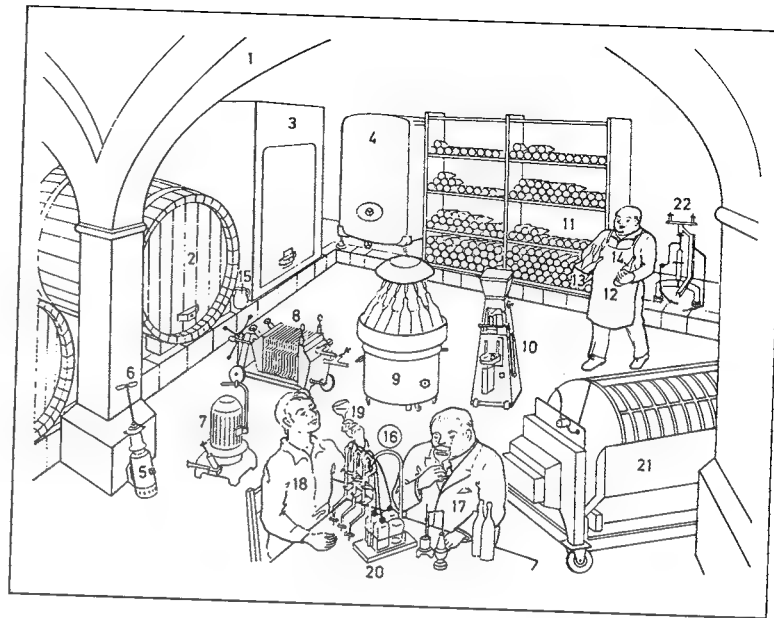
**1-22 wine cellar (wine vault)**

- 1 vault
- 2 wine cask
- 3 wine vat, a concrete vat
- 4 stainless steel vat (*also:* vat made of synthetic material)
- 5 propeller-type high-speed mixer
- 6 propeller mixer
- 7 centrifugal pump
- 8 stainless steel sediment filter
- 9 semi-automatic circular bottling machine
- 10 semi-automatic corking machine
- 11 bottle rack
- 12 cellarer's assistant
- 13 bottle basket
- 14 wine bottle
- 15 wine jug
- 16 wine tasting
- 17 head cellarman
- 18 cellarman
- 19 wineglass
- 20 inspection apparatus [for spot-checking samples]
- 21 horizontal wine press
- 22 humidifier

1-19 fruit pests

- 1 gipsy (gypsy) moth
- 2 batch (cluster) of eggs
- 3 caterpillar
- 4 chrysalis (pupa)
- 5 small ermine moth, an ermine moth
- 6 larva (grub)
- 7 tent
- 8 caterpillar skeletonizing a leaf
- 9 fruit-surface-eating tortrix moth (summer fruit tortrix moth)
- 10 appleblossom weevil, a weevil
- 11 punctured, withered flower (blossom)
- 12 hole for laying eggs
- 13 lackey moth
- 14 caterpillar
- 15 eggs
- 16 winter moth, a geometrid
- 17 caterpillar
- 18 cherry fruit fly, a borer
- 19 larva (grub, maggot)
- 20-27 vine pests**
- 20 downy mildew, a mildew, a disease causing leaf drop
- 21 grape affected with downy mildew
- 22 grape-berry moth
- 23 first-generation larva of the grape-berry moth (*Am. grape worm*)
- 24 second-generation larva of the grape-berry moth (*Am. grape worm*)
- 25 chrysalis (pupa)
- 26 root louse, a grape phylloxera
- 27 root gall (knotty swelling of the root, nodosity, tuberosity)
- 28 brown-tail moth
- 29 caterpillar
- 30 batch (cluster) of eggs
- 31 hibernation cocoon
- 32 woolly apple aphid (American blight), an aphid
- 33 gall caused by the woolly apple aphid
- 34 woolly apple aphid colony

- 35 San-José scale, a scale insect (scale louse)
- 36 larvae (grubs) [*male elongated, female round*]
- 37-55 field pests**
- 37 click beetle, a snapping beetle (*Am. snapping bug*)
- 38 wireworm, larva of the click beetle
- 39 flea beetle
- 40 Hessian fly, a gall midge (gall gnat)
- 41 larva (grub)
- 42 turnip moth, an earth moth
- 43 chrysalis (pupa)
- 44 cutworm, a caterpillar
- 45 beet carrion beetle
- 46 larva (grub)
- 47 large cabbage white butterfly
- 48 caterpillar of the small cabbage white butterfly
- 49 brown leaf-eating weevil, a weevil
- 50 feeding site
- 51 sugar beet eelworm, a nematode (a threadworm, hairworm)
- 52 Colorado beetle (potato beetle)
- 53 mature larva (grub)
- 54 young larva (grub)
- 55 eggs

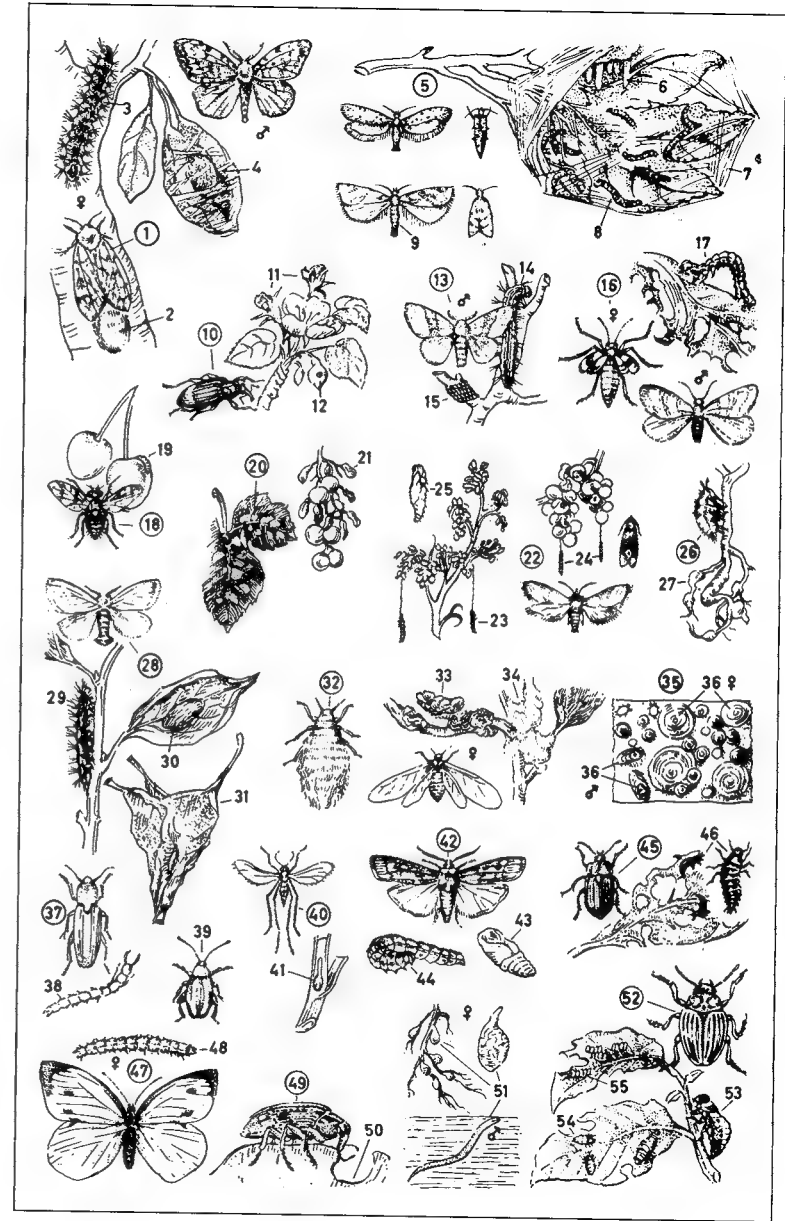

1-14 house insects

- 1 lesser housefly
- 2 common housefly
- 3 chrysalis (pupa, coarctate pupa)
- 4 stable fly (biting housefly)
- 5 trichotomous antenna
- 6 wood louse (slater, *Am.* sow bug)
- 7 house cricket
- 8 wing with stridulating apparatus (stridulating mechanism)
- 9 house spider
- 10 spider's web
- 11 earwig
- 12 caudal pincers
- 13 clothes moth, a moth
- 14 silverfish (*Am.* slicker), a bristletail

15-30 food pests (pests to stores)

- 15 cheese fly
- 16 grain weevil (granary weevil)
- 17 cockroach (black beetle)
- 18 meal beetle (meal worm beetle, flour beetle)
- 19 spotted bruchus
- 20 larva (grub)
- 21 chrysalis (pupa)
- 22 leather beetle (hide beetle)
- 23 yellow meal beetle
- 24 chrysalis (pupa)
- 25 cigarette beetle (tobacco beetle)
- 26 maize billbug (corn weevil)
- 27 one of the *Cryptolestes*, a grain pest
- 28 Indian meal moth
- 29 Angoumois grain moth (Angoumois moth)
- 30 Angoumois grain moth caterpillar inside a grain kernel

31-42 parasites of man

- 31 round worm (maw worm)
- 32 female
- 33 head
- 34 male
- 35 tapeworm, a flatworm
- 36 head, a suckorial organ
- 37 sucker
- 38 crown of hooks
- 39 bug (bed bug, *Am.* chinch)

40 crab louse (a human louse)

- 41 clothes louse (body louse, a human louse)
- 42 flea (human flea, common flea)
- 43 tsetse fly
- 44 malaria mosquito

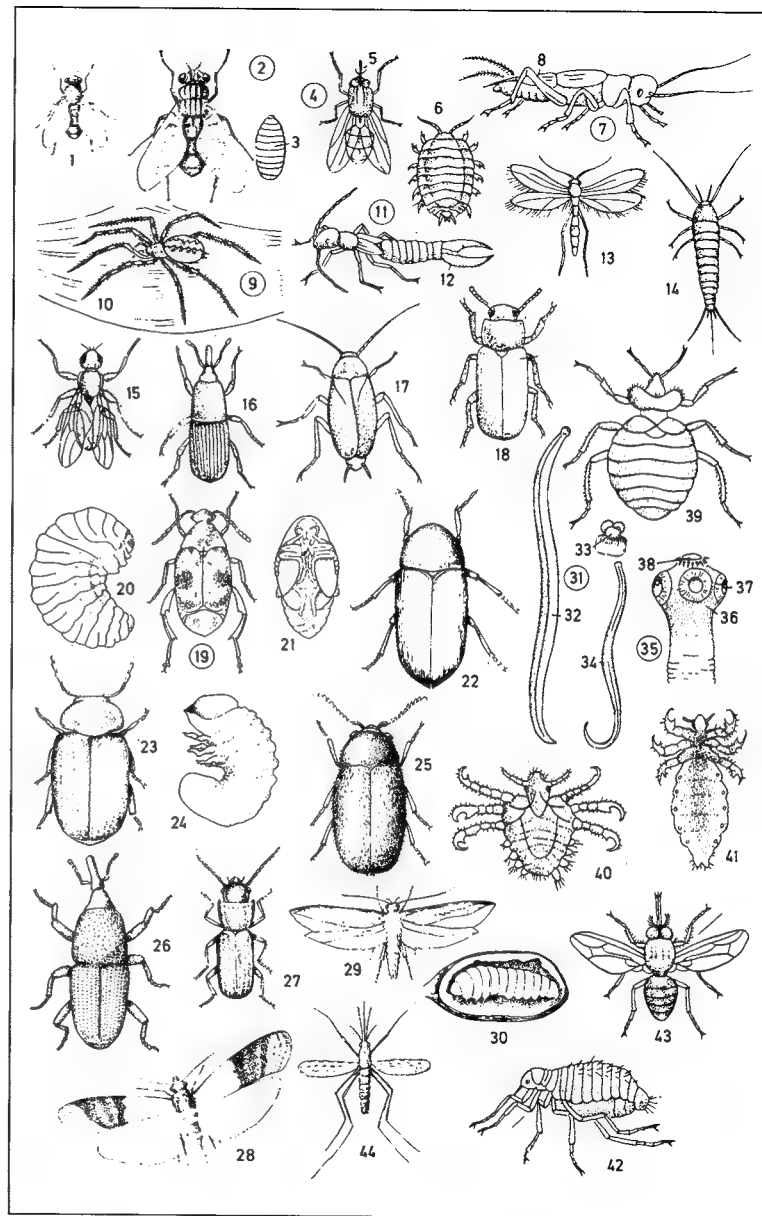

- 1 cockchafer (May bug), a lamellicorn
- 2 head
- 3 antenna (feeler)
- 4 thoracic shield (prothorax)
- 5 scutellum
- 6-8 legs
- 6 front leg
- 7 middle leg
- 8 back leg
- 9 abdomen
- 10 elytron (wing case)
- 11 membranous wing
- 12 cockchafer grub, a larva
- 13 chrysalis (pupa)
- 14 processionary moth, a nocturnal moth (night-flying moth)
- 15 moth
- 16 caterpillars in procession
- 17 nun moth (black arches moth)
- 18 moth
- 19 eggs
- 20 caterpillar
- 21 chrysalis (pupa) in its cocoon
- 22 typographer beetle, a bark beetle
- 23-24 galleries under the bark
- 23 egg gallery
- 24 gallery made by larva
- 25 larva (grub)
- 26 beetle
- 27 pine hawkmoth, a hawkmoth
- 28 pine moth, a geometrid
- 29 male moth
- 30 female moth
- 31 caterpillar
- 32 chrysalis (pupa)
- 33 oak-gall wasp, a gall wasp
- 34 oak gall (oak apple), a gall
- 35 wasp
- 36 larva (grub) in its chamber
- 37 beech gall
- 38 spruce-gall aphid
- 39 winged aphid
- 40 pineapple gall
- 41 pine weevil
- 42 beetle (weevil)
- 43 green oak roller moth (green oak tortrix), a leaf roller
- 44 caterpillar
- 45 moth
- 46 pine beauty
- 47 caterpillar
- 48 moth

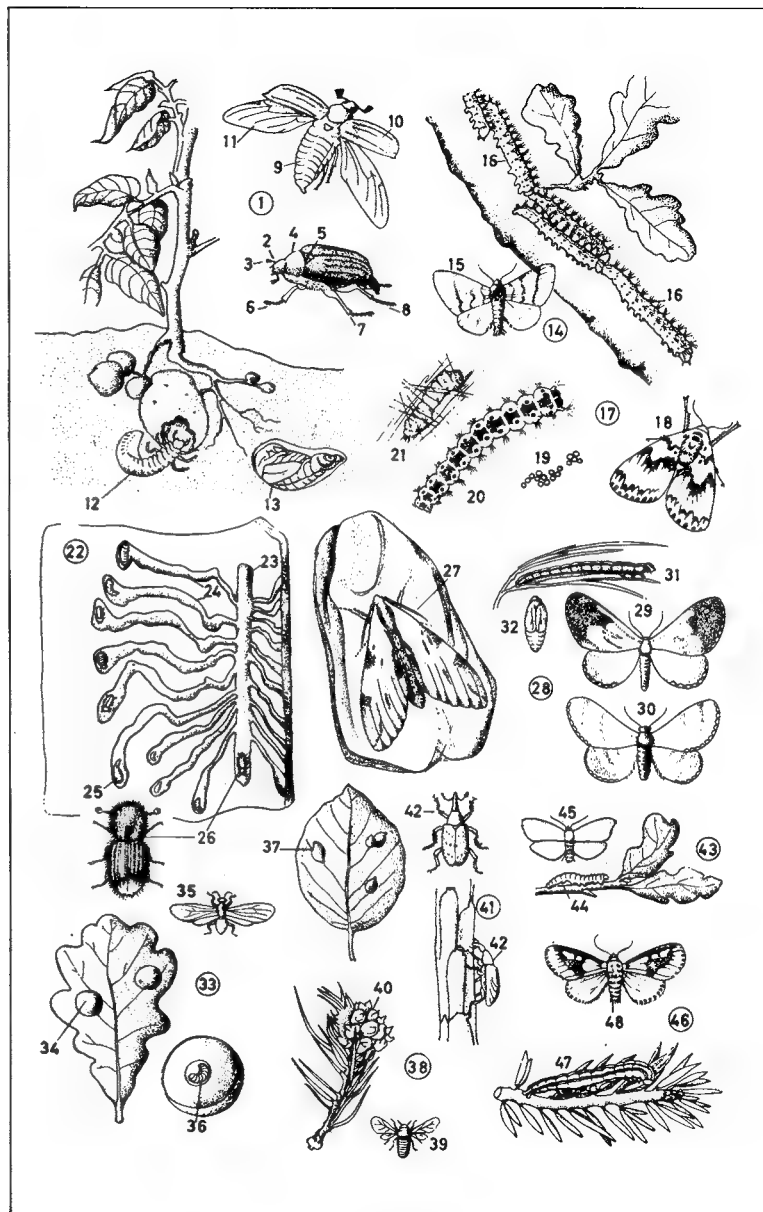

- 1 area spraying
- 2 tractor-mounted sprayer
- 3 spray boom
- 4 fan nozzle
- 5 spray fluid tank
- 6 foam canister for blob marking
- 7 spring suspension
- 8 spray
- 9 blob marker
- 10 foam feed pipe
- 11 vacuum fumigator (vacuum fumigation plant) of a tobacco factory
- 12 vacuum chamber
- 13 bales of raw tobacco
- 14 gas pipe
- 15 mobile fumigation chamber for fumigating nursery saplings, vine layers, seeds, and empty sacks with hydrocyanic (prussic) acid
- 16 gas circulation unit
- 17 tray
- 18 spray gun
- 19 twist grip (control grip, handle) for regulating the jet
- 20 finger guard
- 21 control lever (operating lever)
- 22 spray tube
- 23 cone nozzle
- 24 hand spray
- 25 plastic container
- 26 hand pump
- 27 pendulum spray for hop growing on slopes
- 28 pistol-type nozzle
- 29 spraying tube
- 30 hose connection
- 31 tube for laying poisoned bait
- 32 fly swat
- 33 soil injector (carbon disulphide, *Am.* carbon disulfide, injector) for killing the vine root louse
- 34 foot lever (foot pedal, foot treadle)
- 35 gas tube
- 36 mousetrap
- 37 vole and mole trap
- 38 mobile orchard sprayer, a wheelbarrow sprayer (carriage sprayer)

- 39 spray tank
- 40 screw-on cover
- 41 direct-connected motor-driven pump with petrol motor
- 42 pressure gauge (*Am. gage*) (manometer)
- 43 plunger-type knapsack sprayer
- 44 spray canister with pressure chamber
- 45 piston pump lever
- 46 hand lance with nozzle
- 47 semi-mounted sprayer
- 48 vineyard tractor
- 49 fan
- 50 spray fluid tank
- 51 row of vines
- 52 dressing machine (seed-dressing machine) for dry-seed dressing (seed dusting)
- 53 dedusting fan (dust removal fan) with electric motor
- 54 bag filter
- 55 bagging nozzle
- 56 dedusting screen (dust removal screen)
- 57 water canister [containing water for spraying]
- 58 spray unit
- 59 conveyor unit with mixing screw
- 60 container for disinfectant powder with dosing mechanism
- 61 castor
- 62 mixing chamber

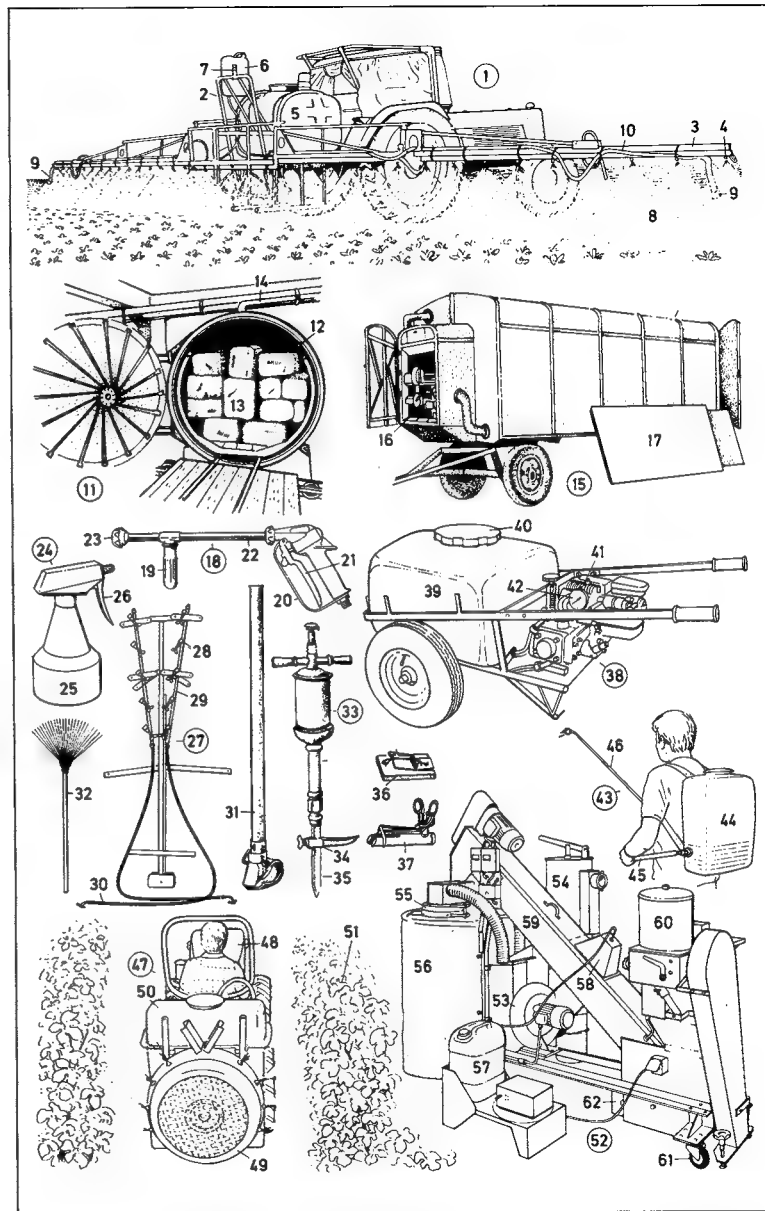

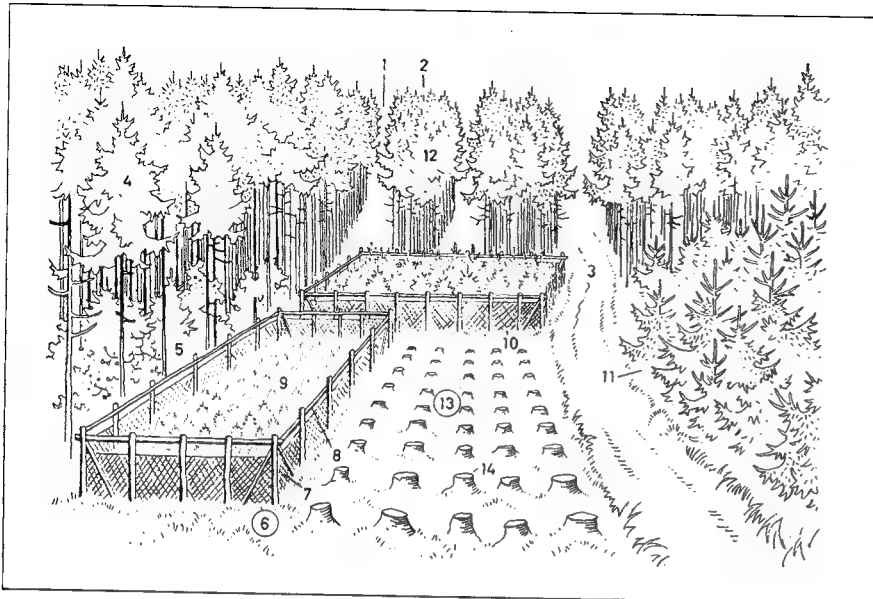
**1-34 forest, a wood**

- 1 ride (aisle, lane, section line)
- 2 compartment (section)
- 3 wood haulage way, a forest track
- 4-14 clear-felling system**
- 4 standing timber
- 5 underwood (underbrush, undergrowth, brushwood, *Am.* brush)
- 6 seedling nursery, a tree nursery
- 7 deer fence (fence), a wire netting fence (protective fence for seedlings); *sim.*: rabbit fence
- 8 guard rail
- 9 seedlings
- 10, 11 young trees
- 10 tree nursery after transplanting
- 11 young plantation
- 12 young plantation after brashing
- 13 clearing
- 14 tree stump (stump, stub)

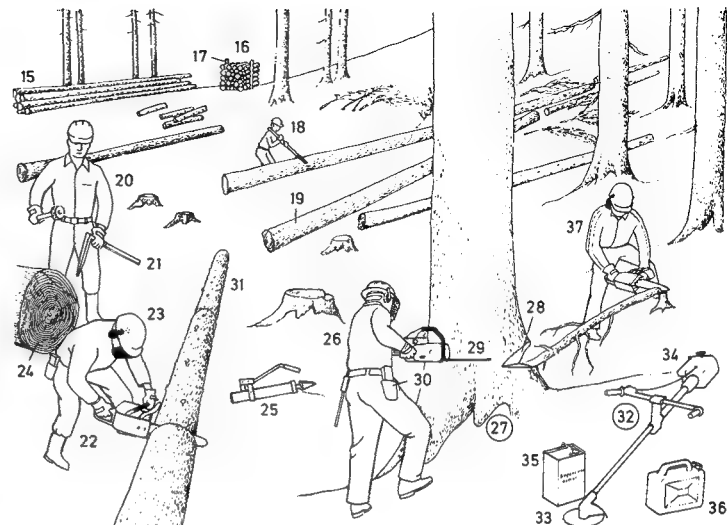
**15-37 wood cutting** (timber cutting, tree felling, *Am.* lumbering)

- 15 timber skidded to the stack (stacked timber, *Am.* yarded timber)
- 16 stack of logs, one cubic metre (*Am.* meter) of wood
- 17 post (stake)
- 18 forest labourer (woodsman, *Am.* logger, lumberer, lumberjack, lumberman, timberjack) turning (*Am.* canting) timber
- 19 bole (tree trunk, trunk, stem)
- 20 feller numbering the logs
- 21 steel tree calliper (caliper)
- 22 power saw (motor saw) cutting a bole
- 23 safety helmet with visor and ear pieces
- 24 annual rings
- 25 hydraulic felling wedge
- 26 protective clothing [orange top, green trousers]
- 27 felling with a power saw (motor saw)
- 28 undercut (notch, throat, gullet, mouth, sink, kerf, birdsmouth)
- 29 back cut
- 30 sheath holding felling wedge
- 31 log
- 32 free-cutting saw for removing underwood and weeds
- 33 circular saw (or activated blade) attachment
- 34 power unit (motor)
- 35 canister of viscous oil for the saw chain
- 36 petrol canister (*Am.* gasoline canister)
- 37 felling of small timber (of small-sized thinnings) (thinning)

85 Forestry II

- 1 axe (*Am.* ax)
- 2 edge (cutting edge)
- 3 handle (helve)
- 4 felling wedge (falling wedge) with wood insert and ring
- 5 riving hammer (cleaving hammer, splitting hammer)
- 6 lifting hook
- 7 cant hook
- 8 barking iron (bark spud)
- 9 peavy
- 10 slide calliper (caliper) (calliper square)
- 11 billhook, a knife for lopping
- 12 revolving die hammer (marking hammer, marking iron, *Am.* marker)
- 13 power saw (motor saw)
- 14 saw chain
- 15 safety brake for the saw chain, with finger guard
- 16 saw guide
- 17 accelerator lock
- 18 snedding machine (trimming machine, *Am.* knotting machine, limbing machine)
- 19 feed rolls
- 20 flexible blade
- 21 hydraulic arm
- 22 trimming blade
- 23 debarking (barking, bark stripping) of boles
- 24 feed roller
- 25 cylinder trimmer
- 26 rotary cutter
- 27 short-haul skidder
- 28 loading crane
- 29 log grips
- 30 post
- 31 Ackermann steering system
- 32 log dump
- 33 number (identification number)
- 34 skidder
- 35 front blade (front plate)
- 36 crush-proof safety bonnet (*Am.* safety hood)
- 37 Ackermann steering system
- 38 cable winch

- 39 cable drum
- 40 rear blade (rear plate)
- 41 boles with butt ends held off the ground
- 42 haulage of timber by road
- 43 tractor (tractor unit)
- 44 loading crane
- 45 hydraulic jack
- 46 cable winch
- 47 post
- 48 bolster plate
- 49 rear bed (rear bunk)

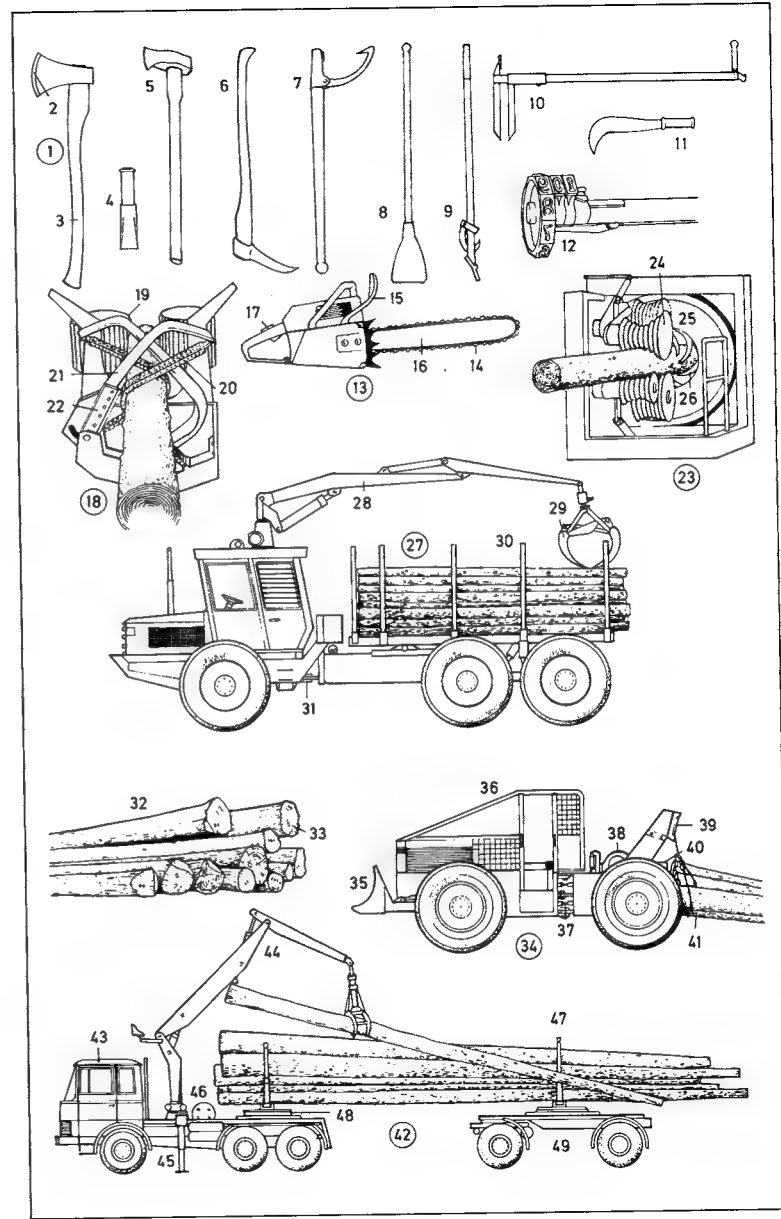

**1-52 kinds of hunting**

1-8 stalking (deer stalking, *Am.* still-hunting) in the game preserve

1 huntsman (hunter)

2 hunting clothes

3 knapsack

4 sporting gun (sporting rifle, hunting rifle)

5 huntsman's hat

6 field glasses, binoculars

7 gun dog

8 track (trail, hoofprints)

9-12 hunting in the rutting season and the pairing season

9 hunting screen (screen, *Am.* blind)

10 shooting stick (shooting seat, seat stick)

11 blackcock, displaying

12 rutting stag

13 hind, grazing

14-17 hunting from a raised hide (raised stand)

14 raised hide (raised stand, high seat)

15 herd within range

16 game path (*Am.* runway)

17 roebuck, hit in the shoulder and killed by a finishing shot

18 phaeton

19-27 types of trapping

19 trapping of small predators

20 box trap (trap for small predators)

21 bait

22 marten, a small predator

23 ferreting (hunting rabbits out of their warrens)

24 ferret

25 ferreter

26 burrow (rabbit burrow, rabbit hole)

27 net (rabbit net) over the burrow opening

28 feeding place for game (winter feeding place)

29 poacher

30 carbine, a short rifle

31 boar hunt

32 wild sow (sow, wild boar)

33 boarhound (hound, hunting dog; collectively: pack, pack of hounds)

34-39 beating (driving, hare hunting)

34 aiming position

35 hare, furred game (ground game)

36 retrieving

37 beater

38 bag (kill)

39 cart for carrying game

40 waterfowling (wildfowling, duck shooting, *Am.* duck hunting)

41 flight of wild ducks, winged game

42-46 falconry (hawking)

42 falconer

43 reward, a piece of meat

44 falcon's hood

45 jess

46 falcon, a hawk, a male hawk (*tier-cel*) swooping (stooping) on a heron

47-52 shooting from a butt

47 tree to which birds are lured

48 eagle owl, a decoy bird (decoy)

49 perch

50 decoyed bird, a crow

51 butt for shooting crows or eagle owls

52 gun slit

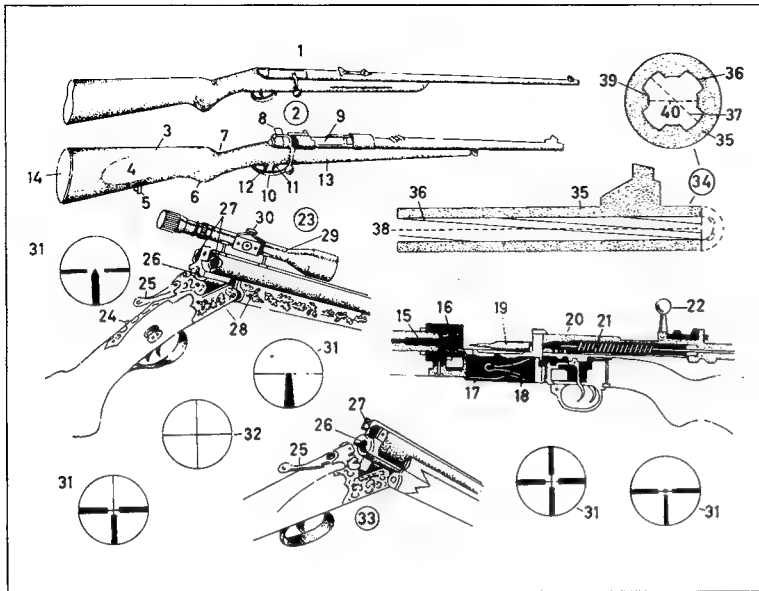

1-40 sporting guns (sporting rifles, hunting rifles)

- | | |
|---|---|
| 1 single-loader (single-loading rifle) | 21 firing pin (striker) |
| 2 repeating rifle, a small-arm (fire-arm), a repeater (magazine rifle, magazine repeater) | 22 bolt handle (bolt lever) |
| 3, 4, 6, 13 stock | 23 triple-barrelled (triple-barreled) rifle, a self-cocking gun |
| 3 butt | 24 reversing catch; <i>in various guns</i> : safety catch |
| 4 cheek [on the left side] | 25 sliding safety catch |
| 5 sling ring | 26 rifle barrel (rifled barrel) |
| 6 pistol grip | 27 smooth-bore barrel |
| 7 small of the butt | 28 chasing |
| 8 safety catch | 29 telescopic sight (riflescope, telescope sight) |
| 9 lock | 30 graticule adjuster screws |
| 10 trigger guard | 31-32 graticule (sight graticule) |
| 11 second set trigger (firing trigger) | 31 various graticule systems |
| 12 hair trigger (set trigger) | 32 cross wires (<i>Am.</i> cross hairs) |
| 13 foregrip | 33 over-and-under shotgun |
| 14 butt plate | 34 rifled gun barrel |
| 15 cartridge chamber | 35 barrel casing |
| 16 receiver | 36 rifling |
| 17 magazine | 37 rifling calibre (<i>Am.</i> caliber) |
| 18 magazine spring | 38 bore axis |
| 19 ammunition (cartridge) | 39 land |
| 20 chamber | 40 calibre (bore diameter, <i>Am.</i> caliber) |

41-48 hunting equipment

- | |
|---|
| 41 double-edged hunting knife |
| 42 [single-edged] hunting knife |
| 43-47 calls for luring game (for calling game) |
| 43 roe call |
| 44 hare call |
| 45 quail call |
| 46 stag call |
| 47 partridge call |
| 48 bow trap (bow gin), a jaw trap |
| 49 small-shot cartridge |
| 50 cardboard case |
| 51 small-shot charge |
| 52 felt wad |
| 53 smokeless powder (<i>different kind</i> : black powder) |
| 54 cartridge |
| 55 full-jacketed cartridge |
| 56 soft-lead core |
| 57 powder charge |
| 58 detonator cap |
| 59 percussion cap |
| 60 hunting horn |
| 61-64 rifle cleaning kit |
| 61 cleaning rod |
| 62 cleaning brush |
| 63 cleaning tow |
| 64 pull-through (<i>Am.</i> pull-thru) |
| 65 sights |
| 66 notch (sighting notch) |
| 67 back sight leaf |
| 68 sight scale division |
| 69 back sight slide |
| 70 notch [to hold the spring] |
| 71 front sight (foresight) |
| 72 bead |
| 73 ballistics |
| 74 azimuth |
| 75 angle of departure |
| 76 angle of elevation |
| 77 apex (zenith) |
| 78 angle of descent |
| 79 ballistic curve |

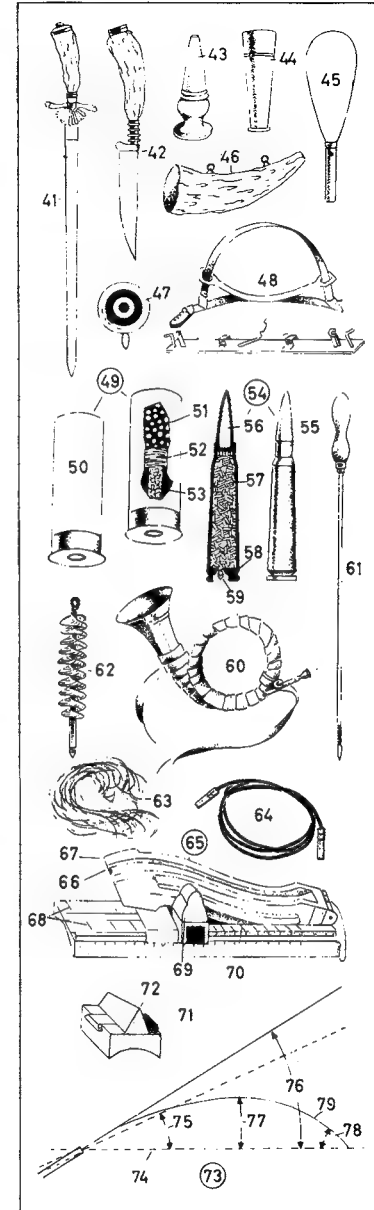

1-27 red deer

- 1 hind (red deer), a young hind or a dam; collectively: antlerless deer, (y.) calf
 2 tongue
 3 neck
 4 rutting stag
 5-11 antlers
 5 burr (rose)
 6 brow antler (brow tine, brow point, brow snag)
 7 bez antler (bay antler, bay, bez tine)
 8 royal antler (royal, tray)
 9 surroyal antlers (surroyals)
 10 point (tine)
 11 beam (main trunk)
 12 head
 13 mouth
 14 larmier (tear bag)
 15 eye
 16 ear
 17 shoulder
 18 loin
 19 scut (tail)
 20 rump
 21 leg (haunch)
 22 hind leg
 23 dew claw
 24 hoof
 25 foreleg
 26 flank
 27 collar (rutting mane)
 28-39 roe (roe deer)
 28 roebuck (buck)
 29-31 antlers (horns)
 29 burr (rose)
 30 beam with pearls
 31 point (tine)
 32 ear
 33 eye
 34 doe (female roe), a female fawn or a barren doe
 35 loin
 36 rump
 37 leg (haunch)
 38 shoulder
 39 fawn, (m.) young buck, (f.) young doe
 40-41 fallow deer
 40 fallow buck, a buck with palmate (palmated) antlers, (f.) doe

- 41 palm
 42 red fox, (m.) dog, (f.) vixen, (y.) cub
 43 eyes
 44 ear
 45 muzzle (mouth)
 46 pads (paws)
 47 brush (tail)
 48 badger, (f.) sow
 49 tail
 50 paws
 51 wild boar, (m.) boar, (f.) wild sow (sow), (y.) young boar
 52 bristles
 53 snout
 54 tusk
 55 shield
 56 hide
 57 dew claw
 58 tail
 59 hare, (m.) buck, (f.) doe
 60 eye
 61 ear
 62 scut (tail)
 63 hind leg
 64 foreleg
 65 rabbit
 66 blackcock
 67 tail
 68 falcate (falcated) feathers
 69 hazel grouse (hazel hen)
 70 partridge
 71 horseshoe (horseshoe marking)
 72 wood grouse (capercaillie)
 73 beard
 74 axillary marking
 75 tail (fan)
 76 wing (pinion)
 77 common pheasant, a pheasant, (m.) cock pheasant (pheasant cock), (f.) hen pheasant (pheasant hen)
 78 plumicorn (feathered ear, ear tuft, ear, horn)
 79 wing
 80 tail
 81 leg
 82 spur
 83 snipe
 84 bill (beak)

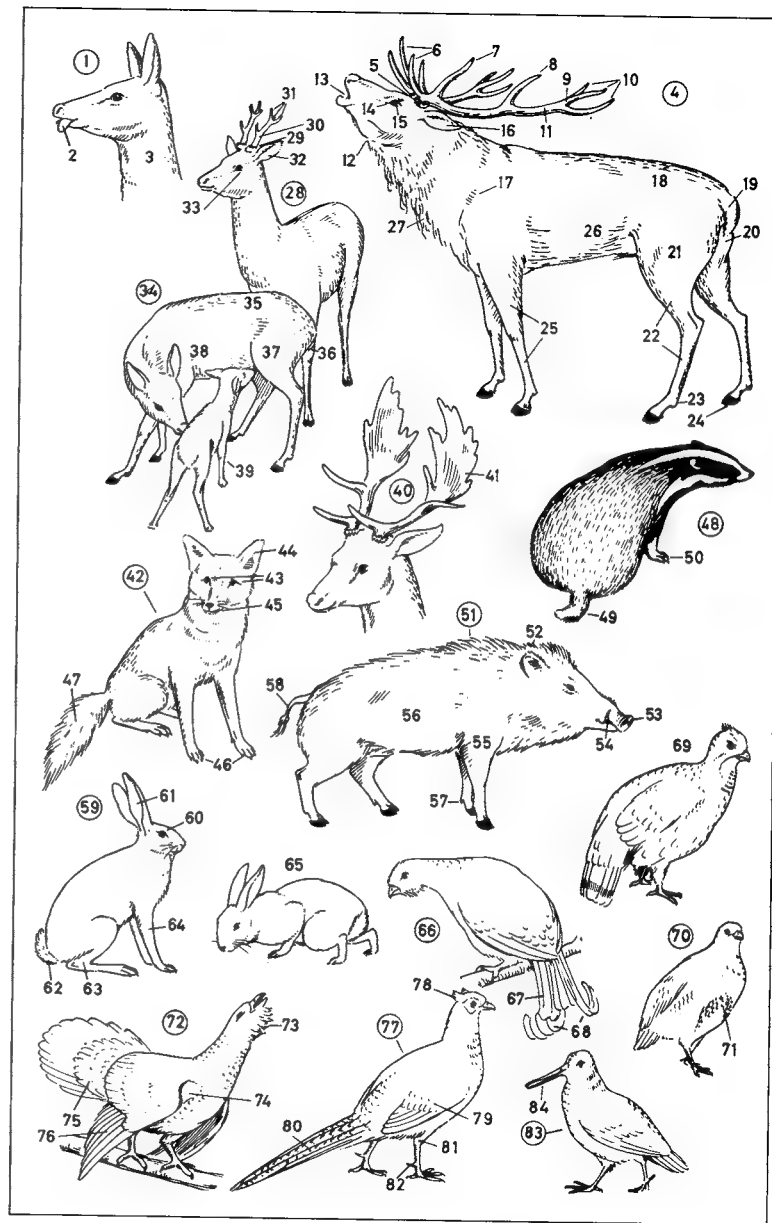

1-19 fish farming (fish culture, pisciculture)

- 1 cage in running water
- 2 hand net (landing net)
- 3 semi-oval barrel for transporting fish
- 4 vat
- 5 trellis in the overflow
- 6 trout pond; *sim.*: carp pond, a fry pond, fattening pond, or cleansing pond
- 7 water inlet (water supply pipe)
- 8 water outlet (outlet pipe)
- 9 monk
- 10 screen

11-19 hatchery

- 11 stripping the spawning pike (seed pike)
- 12 fish spawn (spawn, roe, fish eggs)
- 13 female fish (spawner, seed fish)
- 14 trout breeding (trout rearing)
- 15 Californian incubator
- 16 trout fry
- 17 hatching jar for pike
- 18 long incubation tank
- 19 Brandstetter egg-counting board

20-94 angling**20-31 bottom fishing** (coarse fishing)

- 20 line shooting
- 21 coils
- 22 cloth (rag) or paper
- 23 rod rest
- 24 bait tin
- 25 fish basket (creel)
- 26 fishing for carp from a boat
- 27 rowing boat (fishing boat)
- 28 keep net
- 29 drop net
- 30 pole (punt pole, quant pole)
- 31 casting net
- 32 two-handed side cast with fixed-spool reel

- 33 initial position
- 34 point of release
- 35 path of the rod tip
- 36 trajectory of the baited weight

37-94 fishing tackle

- 37 fishing pliers
- 38 filleting knife
- 39 fish knife
- 40 disgorger (hook disgorger)
- 41 bait needle
- 42 gag
- 43-48 floats**
- 43 sliding cork float
- 44 plastic float
- 45 quill float
- 46 polystyrene float
- 47 oval bubble float
- 48 lead-weighted sliding float

49-58 rods

- 49 solid glass rod
- 50 cork handle (cork butt)
- 51 spring-steel ring
- 52 top ring (end ring)
- 53 telescopic rod
- 54 rod section
- 55 bound handle (bound butt)
- 56 ring
- 57 carbon-fibre rod; *sim.*: hollow glass rod
- 58 all-round ring (butt ring for long cast), a steel bridge ring

59-64 reels

- 59 multiplying reel (multiplier reel)
- 60 line guide
- 61 fixed-spool reel (stationary-drum reel)
- 62 bale arm
- 63 fishing line
- 64 controlling the cast with the index finger

65-76 baits

- 65 fly
- 66 artificial nymph
- 67 artificial earthworm
- 68 artificial grasshopper
- 69 single-jointed plug (single-jointed wobbler)
- 70 double-jointed plug (double-jointed wobbler)
- 71 round wobbler
- 72 wiggler
- 73 spoon bait (spoon)
- 74 spinner
- 75 spinner with concealed hook
- 76 long spinner
- 77 swivel
- 78 cast (leader)

79-87 hooks

- 79 fish hook
- 80 point of the hook with barb
- 81 bend of the hook
- 82 spade (eye)
- 83 open double hook
- 84 limerick
- 85 closed treble hook (triangle)
- 86 carp hook
- 87 eel hook

88-92 leads (lead weights)

- 88 oval lead (oval sinker)
- 89 lead shot
- 90 pear-shaped lead
- 91 plummet
- 92 sea lead
- 93 fish ladder (fish pass, fish way)
- 94 stake net

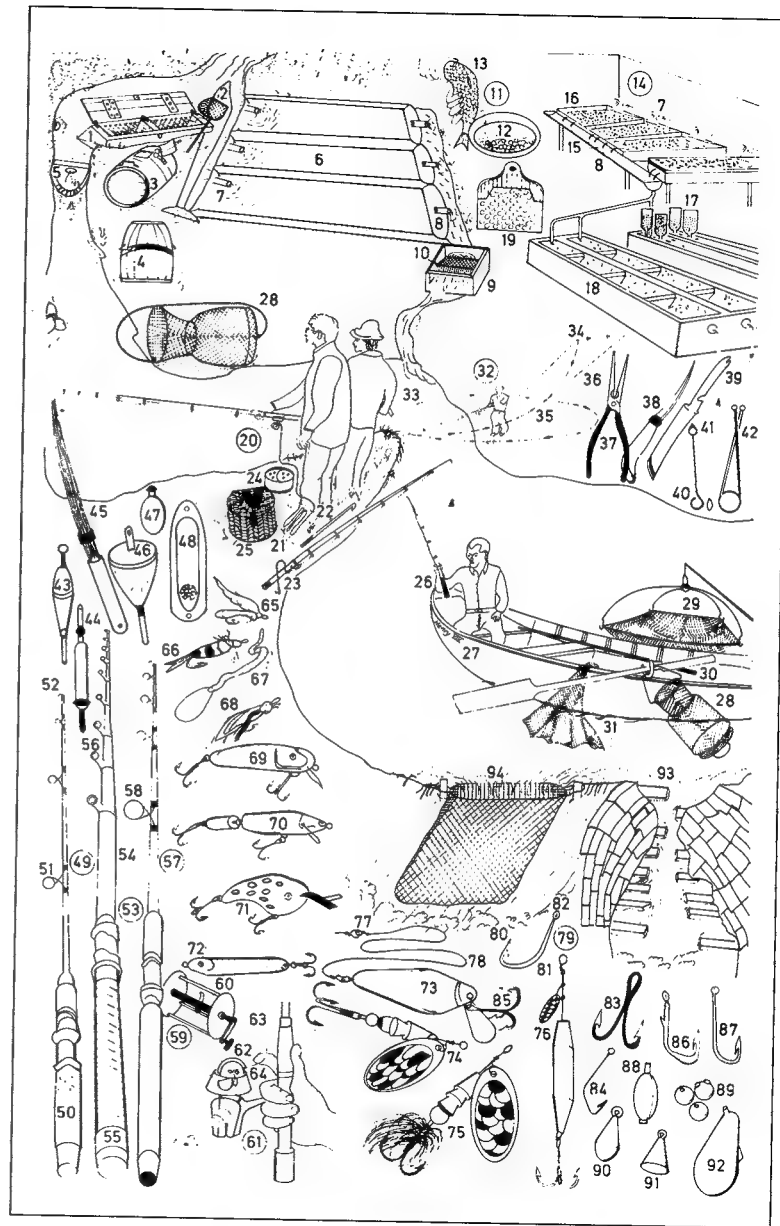

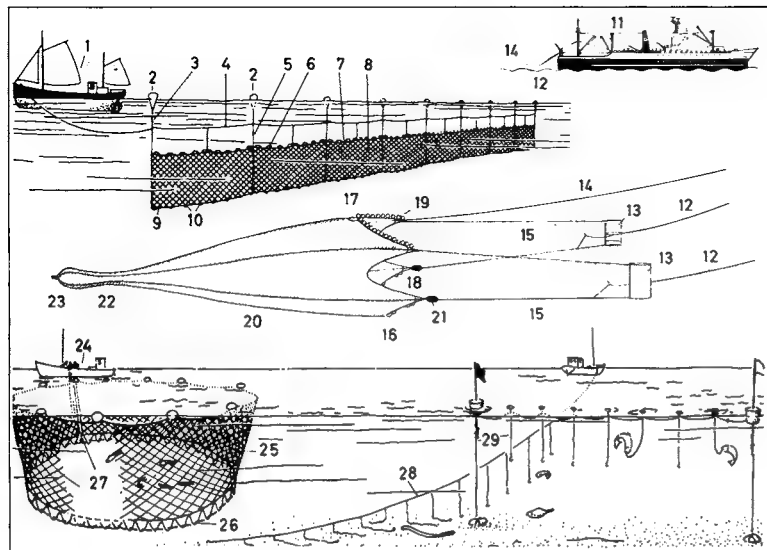
**1-23 deep-sea fishing****1-10 drift net fishing**

1 herring lugger (fishing lugger, lugger)

2-10 herring drift net

2 buoy

3 buoy rope

4 float line

5 seizing

6 wooden float

7 headline

8 net

9 footrope

10 sinkers (weights)

11-23 trawl fishing (trawling)

11 factory ship, a trawler

12 warp (trawl warp)

13 otter boards

14 net sonar cable

15 wire warp

16 wing

17 net sonar device

18 footrope

19 spherical floats

20 belly

21 1,800 kg iron weight

22 cod end (cod)

23 cod line for closing the cod end

24-29 inshore fishing

24 fishing boat

25 ring net cast in a circle

26 cable for closing the ring net

27 closing gear

28-29 long-line fishing (long-lining)

28 long line

29 suspended fishing tackle

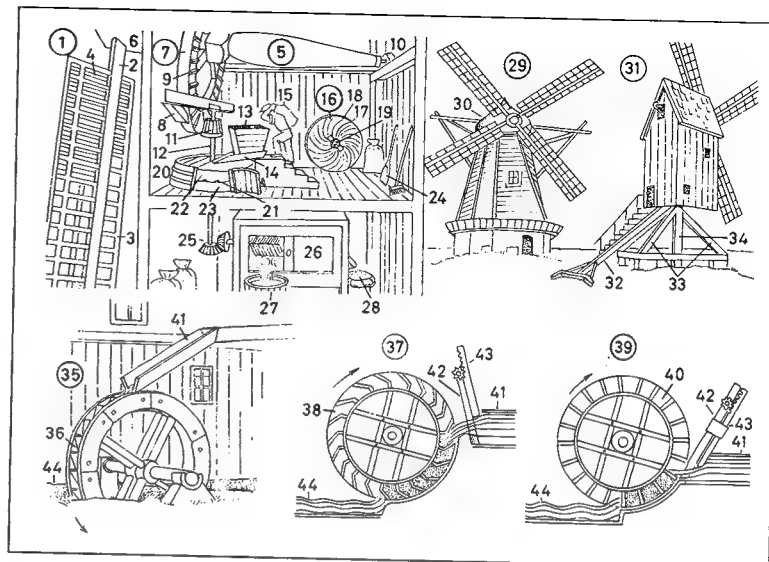
**1-34 windmill**

1 windmill vane (windmill sail, windmill arm)

2 stock (middling, back, radius)

3 frame

4 shutter

5 wind shaft (sail axle)

6 sail top

7 brake wheel

8 brake

9 wooden cog

10 pivot bearing (step bearing)

11 wallower

12 mill spindle

13 hopper

14 shoe (trough, spout)

15 miller

16 millstone

17 furrow (flute)

18 master furrow

19 eye

20 hurst (millstone casing)

21 set of stones (millstones)

22 runner (upper millstone)

23 bed stone (lower stone, bedder)

24 wooden shovel

25 bevel gear (bevel gearing)

26 bolter (sifter)

27 wooden tub (wooden tun)

28 flour

29 smock windmill (Dutch windmill)

30 rotating (revolving) windmill cap

31 post windmill (German windmill)

32 tailpole (pole)

33 base

34 post

35-44 watermill

35 overshot mill wheel (high-breast mill wheel), a mill wheel (water-wheel)

36 bucket (cavity)

37 middleshot mill wheel (breast mill wheel)

38 curved vane

39 undershot mill wheel

40 flat vane

41 headrace (discharge flume)

42 mill weir

43 overfall (water overfall)

44 millstream (millrace, *Am.* raceway)

1-41 preparation of malt (malting)

- 1 malting tower (maltings)
- 2 barley hopper
- 3 washing floor with compressed-air washing unit
- 4 outflow condenser
- 5 water-collecting tank
- 6 condenser for the steep liquor
- 7 coolant collecting plant
- 8 steeping floor (steeping tank, dressing floor)
- 9 cold water tank
- 10 hot water tank
- 11 pump room
- 12 pneumatic plant
- 13 hydraulic plant
- 14 ventilation shaft (air inlet and outlet)
- 15 exhaust fan
- 16-18 kilning floors**
- 16 drying floor
- 17 burner ventilator
- 18 curing floor
- 19 outlet duct from the kiln
- 20 finished malt collecting hopper
- 21 transformer station
- 22 cooling compressors
- 23 green malt (germinated barley)
- 24 turner (plough)
- 25 central control room with flow diagram
- 26 screw conveyor
- 27 washing floor
- 28 steeping floor
- 29 drying kiln
- 30 curing kiln
- 31 barley silo
- 32 weighing apparatus
- 33 barley elevator
- 34 three-way chute (three-way tippler)
- 35 malt elevator
- 36 cleaning machine
- 37 malt silo
- 38 corn removal by suction
- 39 sacker
- 40 dust extractor

41 barley reception**42-53 mashing process in the mash-house**

- 42 premasher (converter) for mixing grist and water
- 43 mash tub (mash tun) for mashing the malt
- 44 mash copper (mash tun, *Am.* mash kettle) for boiling the mash
- 45 dome of the tun
- 46 propeller (paddle)
- 47 sliding door
- 48 water (liquor) supply pipe
- 49 brewer (master brewer, masher)
- 50 lauter tun for settling the draff (grains) and filtering off the wort
- 51 lauter battery for testing the wort for quality
- 52 hop boiler (wort boiler) for boiling the wort
- 53 ladle-type thermometer (scoop thermometer)

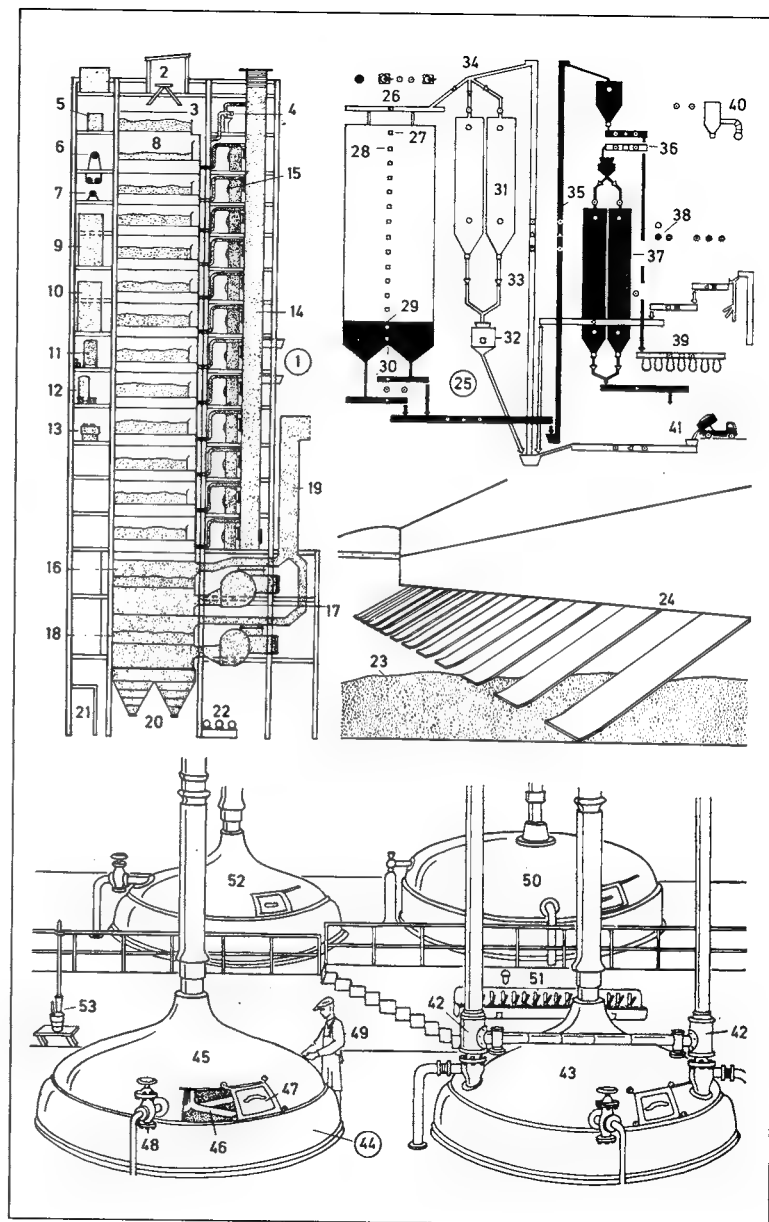

1-31 brewery (brewhouse)

1-5 wort cooling and break removal
(trub removal)

- 1 control desk (control panel)
- 2 whirlpool separator for removing the hot break (hot trub)
- 3 measuring vessel for the kieselguhr
- 4 kieselguhr filter
- 5 wort cooler
- 6 pure culture plant for yeast (yeast propagation plant)
- 7 fermenting cellar
- 8 fermentation vessel (fermenter)
- 9 fermentation thermometer (mash thermometer)

- 10 mash
- 11 refrigeration system
- 12 lager cellar
- 13 manhole to the storage tank
- 14 broaching tap
- 15 beer filter
- 16 barrel store
- 17 beer barrel, an aluminium (*Am.* aluminum) barrel
- 18 bottle-washing plant
- 19 bottle-washing machine (bottle washer)
- 20 control panel
- 21 cleaned bottles
- 22 bottling
- 23 forklift truck (fork truck, forklift)
- 24 stack of beer crates
- 25 beer can
- 26 beer bottle, a Eurobottle with bottled beer; *kinds of beer*: light beer (lager, light ale, pale ale or bitter), dark beer (brown ale, mild), Pilsener beer, Munich beer, malt beer, strong beer (bock beer), porter, ale, stout, Salvator beer, wheat beer, small beer
- 27 crown cork (crown cork closure)
- 28 disposable pack (carry-home pack)
- 29 non-returnable bottle (single-trip bottle)
- 30 beer glass
- 31 head

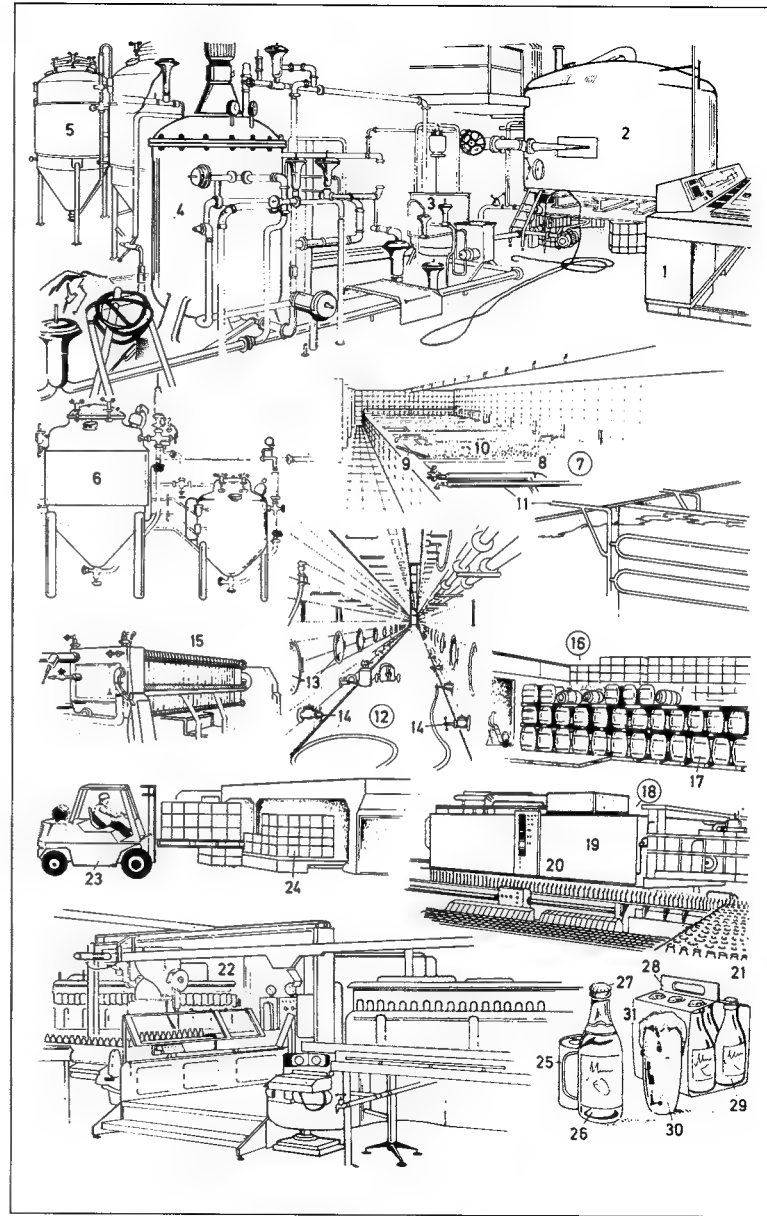

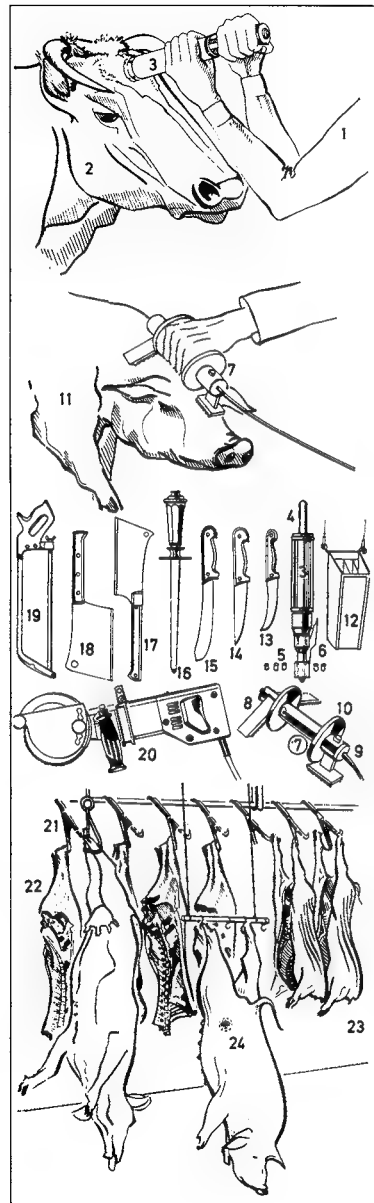

- 1 slaughterman (*Am.* slaughterer, killer)
- 2 animal for slaughter, an ox
- 3 captive-bolt pistol (pneumatic gun), a stunning device
- 4 bolt
- 5 cartridges
- 6 release lever (trigger)
- 7 electric stunner
- 8 electrode
- 9 lead
- 10 hand guard (insulation)
- 11 pig (*Am.* hog) for slaughter
- 12 knife case
- 13 flaying knife
- 14 sticking knife (sticker)
- 15 butcher's knife (butcher knife)
- 16 steel
- 17 splitter
- 18 cleaver (butcher's cleaver, meat axe (*Am.* meat ax))
- 19 bone saw (butcher's saw)
- 20 meat saw for sawing meat into cuts
- 21-24 cold store (cold room)
- 21 gambrel (gambrel stick)
- 22 quarter of beef
- 23 side of pork
- 24 meat inspector's stamp

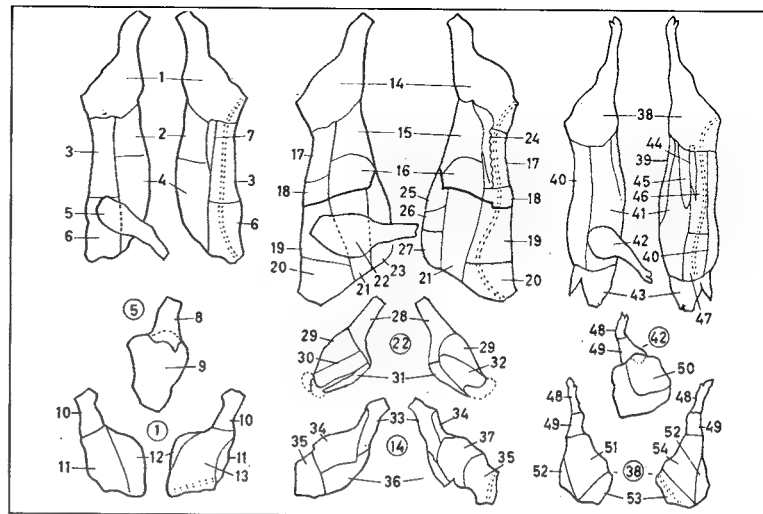

left: meat side;
right: bone side

1-13 animal: calf; meat: veal

- 1 leg with hind knuckle
- 2 flank
- 3 loin and rib
- 4 breast (breast of veal)
- 5 shoulder with fore knuckle
- 6 neck with scrag (scrag end)
- 7 best end of loin (of loin of veal)
- 8 fore knuckle
- 9 shoulder
- 10 hind knuckle
- 11 roasting round (oyster round)
- 12 cutlet for frying or braising
- 13 undercut (fillet)
- 14-37 animal: ox; meat: beef**
- 14 round with rump and shank
- 15-16 flank**
- 15 thick flank
- 16 thin flank
- 17 sirloin
- 18 prime rib (fore ribs, prime fore rib)
- 19 middle rib and chuck
- 20 neck
- 21 flat rib
- 22 leg of mutton piece (bladebone) with shin
- 23 brisket (brisket of beef)
- 24 fillet (fillet of beef)
- 25 hind brisket

- 26 middle brisket
- 27 breastbone
- 28 shin
- 29 leg of mutton piece
- 30 bladebone [meat side]
- 31 part of top rib
- 32 bladebone [bone side]
- 33 shank
- 34 silverside
- 35 rump
- 36 thick flank
- 37 top side
- 38-54 animal: pig; meat: pork**
- 38 leg with knuckle and trotter
- 39 ventral part of the belly
- 40 back fat
- 41 belly
- 42 bladebone with knuckle and trotter
- 43 head (pig's head)
- 44 fillet (fillet of pork)
- 45 leaf fat (pork flare)
- 46 loin (pork loin)
- 47 spare rib
- 48 trotter
- 49 knuckle
- 50 butt
- 51 fore end (ham)
- 52 round end for boiling
- 53 fat end
- 54 gammon steak

**1-30 butcher's shop****1-4 meat**

- 1 ham on the bone
- 2 flitch of bacon
- 3 smoked meat
- 4 piece of loin (piece of sirloin)
- 5 lard

6-11 sausages

- 6 price label
- 7 mortadella
- 8 scalded sausage; *kinds:* Vienna sausage (Wiener), Frankfurter sausage (Frankfurter)
- 9 collared pork (*Am.* headcheese)
- 10 ring of [Lyoner] sausage
- 11 pork sausages; *also:* beef sausages
- 12 cold shelves
- 13 meat salad (diced meat salad)
- 14 cold meats (*Am.* cold cuts)
- 15 pâté
- 16 mince (mincemeat, minced meat)
- 17 knuckle of pork
- 18 basket for special offers

19 price list for special offers

- 20 special offer
- 21 freezer
- 22 pre-packed joints
- 23 deep-frozen ready-to-eat meal
- 24 chicken
- 25 canned food
- 26 can
- 27 canned vegetables
- 28 canned fish
- 29 salad cream
- 30 soft drinks

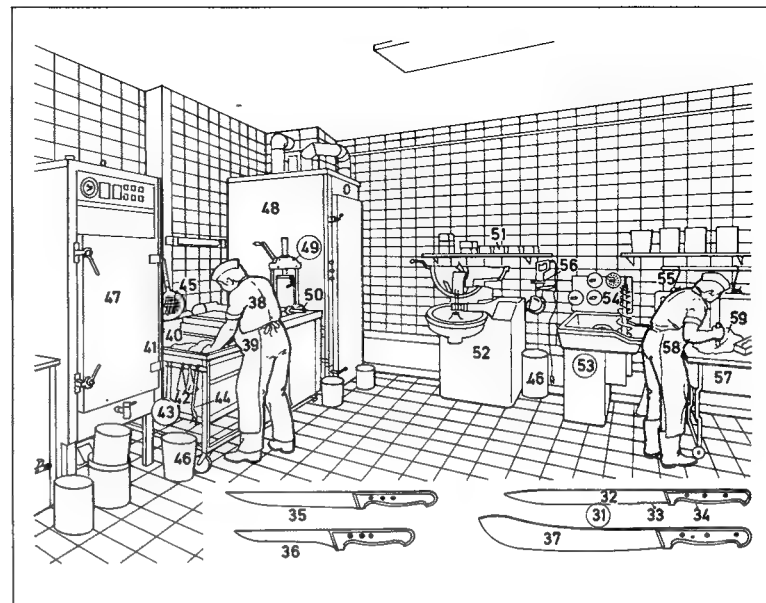
**31-59 manufacture of sausages****31-37 butcher's knives**

- 31 slicer
- 32 knife blade
- 33 saw teeth
- 34 knife handle
- 35 carver (carving knife)
- 36 boning knife
- 37 butcher's knife (butcher knife)
- 38 butcher (master butcher)
- 39 butcher's apron
- 40 meat-mixing trough
- 41 sausage meat
- 42 scraper
- 43 skimmer
- 44 sausage fork
- 45 scalding colander
- 46 waste bin (*Am.* trash bin)
- 47 cooker, for cooking with steam or hot air
- 48 smoke house
- 49 sausage filler (sausage stuffer)
- 50 feed pipe (supply pipe)

51 containers for vegetables

- 52 mincing machine for sausage meat
- 53 mincing machine (meat mincer, mincer, *Am.* meat grinder)
- 54 plates (steel plates)
- 55 meathook (butcher's hook)
- 56 bone saw
- 57 chopping board
- 58 butcher, cutting meat
- 59 piece of meat

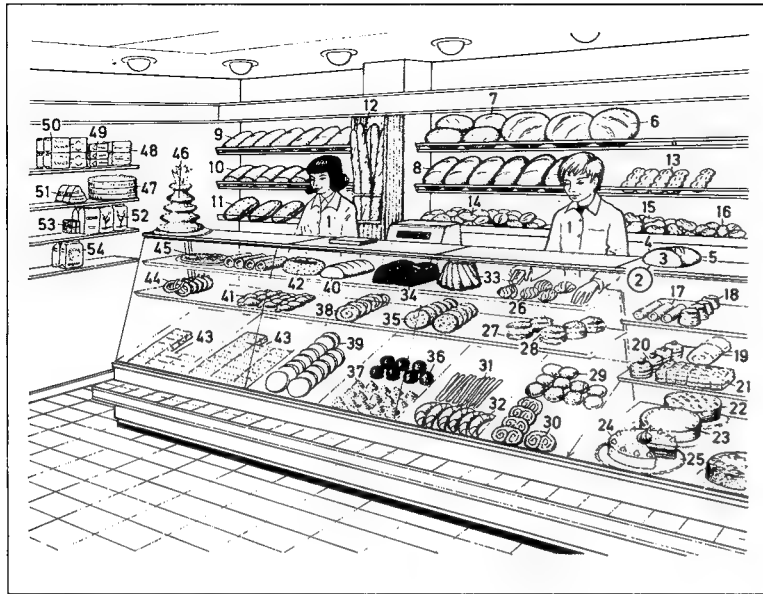
**1-54 baker's shop**

- 1 shop assistant (*Am.* salesgirl, saleslady)
 2 bread (loaf of bread, loaf)
 3 crumb
 4 crust (bread crust)
 5 crust (*Am.* heel)
6-12 kinds of bread (breads)
 6 round loaf, a wheat and rye bread
 7 small round loaf
 8 long loaf (bloomer), a wheat and rye bread
 9 white loaf
 10 pan loaf, a wholemeal rye bread
 11 yeast bread (*Am.* stollen)
 12 French loaf (baguette, French stick)
13-16 rolls
 13 brown roll
 14 white roll
 15 finger roll
 16 rye-bread roll
17-47 cakes (confectionery)
 17 cream roll
 18 vol-au-vent, a puff pastry (*Am.* puff paste)
 19 Swiss roll (*Am.* jelly roll)
 20 tartlet
 21 cream slice
22-24 flans (*Am.* pies) and **gateaux** (torten)
 22 fruit flan (*kinds:* strawberry flan, cherry flan, gooseberry flan, peach flan, rhubarb flan)
 23 cheesecake
 24 cream cake (*Am.* cream pie) (*kinds:* butter-cream cake, Black Forest gateau)
 25 cake plate
 26 meringue
 27 cream puff
 28 whipped cream
 29 doughnut (*Am.* bismarck)
 30 Danish pastry
 31 saltstick (*Salzstange*) (*also:* caraway roll, caraway stick)
 32 croissant (crescent roll, *Am.* crescent)

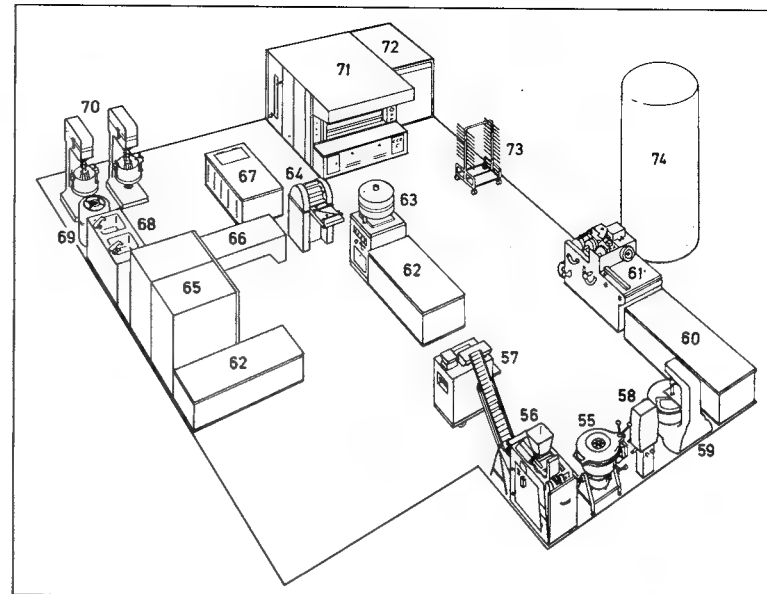

- 33 ring cake (gugelhupf)
 34 slab cake with chocolate icing
 35 streusel cakes
 36 marshmallow
 37 coconut macaroon
 38 pastry whirl
 39 iced bun
 40 sweet bread
 41 plaited bun (plait)
 42 Frankfurter garland cake
 43 slices (*kinds:* streusel slices, sugared slices, plum slices)
 44 pretzel
 45 wafer (*Am.* waffle)
 46 tree cake (baumkuchen)
 47 flan case
48-50 wrapped bread
 48 wholemeal bread (*also:* wheatgerm bread)
 49 pumpernickel (wholemeal rye bread)
 50 crispbread
 51 gingerbread (*Am.* lebkuchen)
 52 flour (*kinds:* wheat flour, rye flour)
 53 yeast (baker's yeast)
 54 rusks (French toast)
55-74 bakery (bakehouse)
 55 kneading machine (dough mixer)
56-57 bread unit
 56 divider
 57 moulder (*Am.* molder)
 58 premixer
 59 dough mixer
 60 workbench
 61 roll unit
 62 workbench
 63 divider and rounder (rounding machine)
 64 crescent-forming machine
 65 freezers
 66 oven [for baking with fat]
67-70 confectionery unit
 67 cooling table
 68 sink
 69 boiler
 70 whipping unit [with beater]
 71 reel oven (oven)
 72 fermentation room
 73 fermentation trolley
 74 flour silo

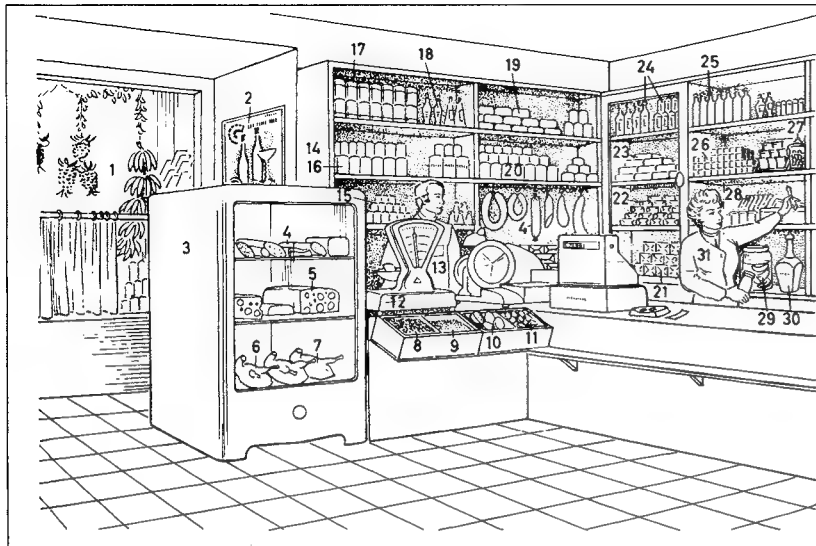

1-87 grocer's shop (grocer's, delicatessen shop, *Am.* grocery store, delicatessen store), a retail shop (*Am.* retail store)

- 1 window display
- 2 poster (advertisement)
- 3 cold shelves
- 4 sausages
- 5 cheese
- 6 roasting chicken (broiler)
- 7 poulard, a fattened hen
- 8-11 baking ingredients**
- 8 raisins; *sim.*: sultanas
- 9 currants
- 10 candied lemon peel
- 11 candied orange peel
- 12 computing scale, a rapid scale
- 13 shop assistant (*Am.* salesclerk)
- 14 goods shelves (shelves)
- 15-20 canned food**
- 15 canned milk
- 16 canned fruit (cans of fruit)
- 17 canned vegetables
- 18 fruit juice
- 19 sardines in oil, a can of fish
- 20 canned meat (cans of meat)
- 21 margarine

- 22 butter
- 23 coconut oil, a vegetable oil
- 24 oil; *kinds*: salad oil, olive oil, sunflower oil, wheatgerm oil, groundnut oil
- 25 vinegar
- 26 stock cube
- 27 bouillon cube
- 28 mustard
- 29 pickled gherkin
- 30 soup seasoning
- 31 shop assistant (*Am.* salesgirl, saleslady)
- 32-34 pastas**
- 32 spaghetti
- 33 macaroni
- 34 noodles
- 35-39 cereal products**
- 35 pearl barley
- 36 semolina
- 37 rolled oats (porridge oats, oats)
- 38 rice
- 39 sago
- 40 salt
- 41 grocer (*Am.* groceryman), a shopkeeper (tradesman, retailer, *Am.* storekeeper)

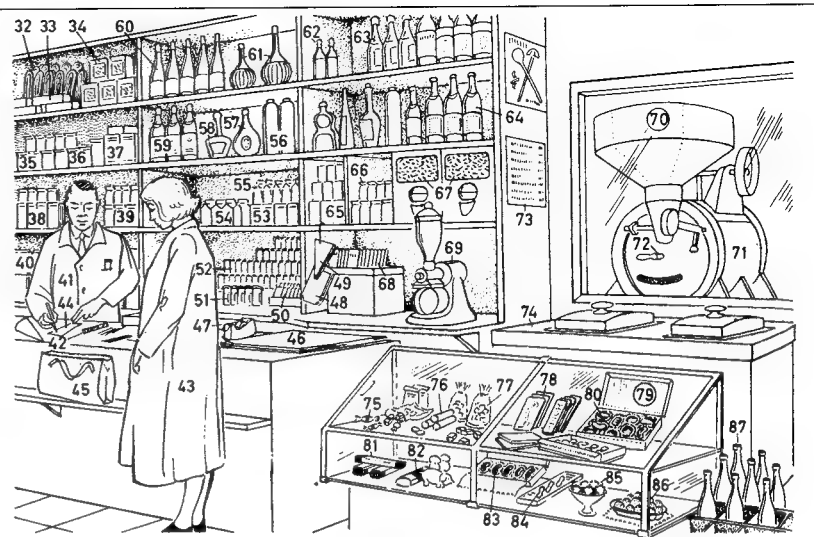

- 42 capers
- 43 customer
- 44 receipt (sales check)
- 45 shopping bag
- 46-49 wrapping material**
- 46 wrapping paper
- 47 adhesive tape
- 48 paper bag
- 49 cone-shaped paper bag
- 50 blancmange powder
- 51 whole-fruit jam (preserve)
- 52 jam
- 53-55 sugar**
- 53 cube sugar
- 54 icing sugar (*Am.* confectioner's sugar)
- 55 refined sugar in crystals
- 56-59 spirits**
- 56 whisky (whiskey)
- 57 rum
- 58 liqueur
- 59 brandy (cognac)
- 60-64 wine in bottles (bottled wine)**
- 60 white wine
- 61 Chianti
- 62 vermouth
- 63 sparkling wine

- 64 red wine
- 65-68 tea, coffee, etc.**
- 65 coffee (pure coffee)
- 66 cocoa
- 67 coffee
- 68 tea bag
- 69 electric coffee grinder
- 70 coffee roaster
- 71 roasting drum
- 72 sample scoop
- 73 price list
- 74 freezer
- 75-86 confectionery** (*Am.* candies)
- 75 sweet (*Am.* candy)
- 76 drops
- 77 toffees
- 78 bar of chocolate
- 79 chocolate box
- 80 chocolate, a sweet
- 81 nougat
- 82 marzipan
- 83 chocolate liqueur
- 84 Turkish delight
- 85 croquant
- 86 truffle
- 87 soda water

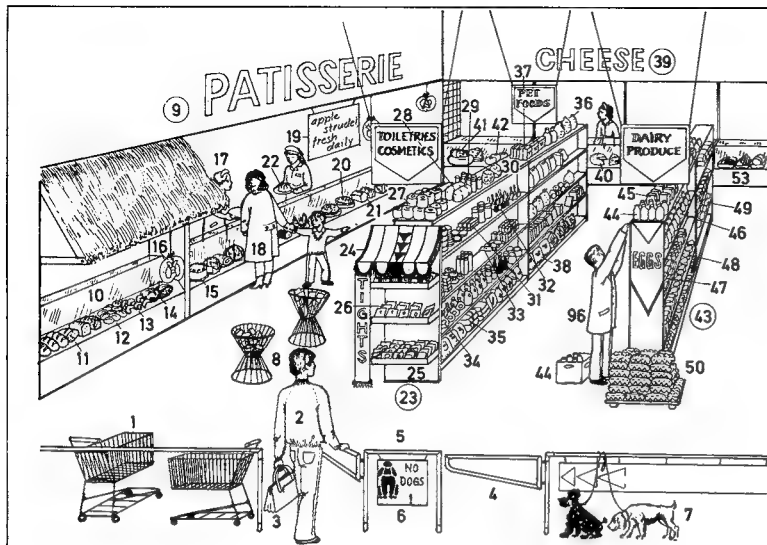

1-96 supermarket, a self-service food store

- 1 shopping trolley
- 2 customer
- 3 shopping bag
- 4 entrance to the sales area
- 5 barrier
- 6 sign (notice) banning dogs
- 7 dogs tied by their leads
- 8 basket
- 9 bread and cake counter (bread counter, cake counter)
- 10 display counter for bread and cakes
- 11 kinds of bread (breads)
- 12 rolls
- 13 croissants (crescent rolls, *Am.* crescents)
- 14 round loaf
- 15 gateau
- 16 pretzel [made with yeast dough]
- 17 shop assistant (*Am.* salesgirl, saleslady)
- 18 customer
- 19 sign listing goods
- 20 fruit flan
- 21 slab cake
- 22 ring cake
- 23 cosmetics gondola, a gondola (sales shelves)

- 24 canopy
- 25 hosiery shelf
- 26 stockings (nylons)
- 27-35 toiletries (cosmetics)
- 27 jar of cream (cream; *kinds:* moisturising cream, day cream, night-care cream, hand cream)
- 28 packet of cotton wool
- 29 talcum powder
- 30 packet of cotton wool balls
- 31 toothpaste
- 32 nail varnish (nail polish)
- 33 shaving cream
- 34 bath salts
- 35 sanitary articles
- 36, 37 pet foods
- 36 complete dog food
- 37 packet of dog biscuits
- 38 bag of cat litter
- 39 cheese counter
- 40 whole cheese
- 41 Swiss cheese (Emmental cheese) with holes
- 42 Edam cheese, a round cheese
- 43 gondola for dairy products
- 44 long-life milk; *also:* pasteurized milk, homogenized milk)
- 45 plastic milk bag

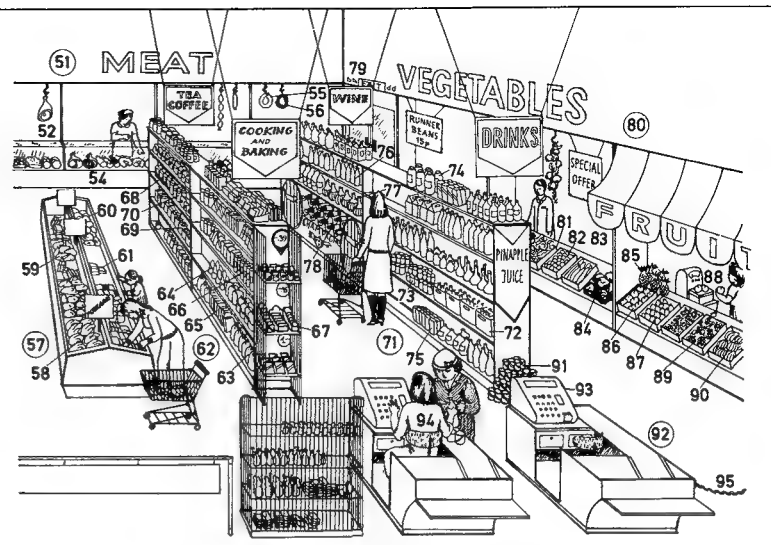

- 46 cream
- 47 butter
- 48 margarine
- 49 box of cheeses
- 50 box of eggs
- 51 fresh meat counter (meat counter)
- 52 ham on the bone
- 53 meat (meat products)
- 54 sausages
- 55 ring of pork sausage
- 56 ring of blood sausage
- 57 freezer
- 58-61 frozen food
- 58 poulard
- 59 turkey leg (drumstick)
- 60 boiling fowl
- 61 frozen vegetables
- 62 gondola for baking ingredients and cereal products
- 63 wheat flour
- 64 sugar loaf
- 65 packet of noodles
- 66 salad oil
- 67 packet of spice
- 68-73 tea, coffee, etc.
- 68 coffee
- 69 packet of tea
- 70 instant coffee

- 71 drinks gondola
- 72 soft drinks
- 73 can of beer
- 74 bottle of fruit juice
- 75 can of fruit juice
- 76 bottle of wine
- 77 bottle of Chianti
- 78 bottle of champagne
- 79 emergency exit
- 80 fruit and vegetable counter
- 81 vegetable basket
- 82 tomatoes
- 83 cucumbers
- 84 cauliflower
- 85 pineapple
- 86 apples
- 87 pears
- 88 scales for weighing fruit
- 89 grapes (bunches of grapes)
- 90 bananas
- 91 can
- 92 checkout
- 93 cash register
- 94 cashier
- 95 chain
- 96 assistant departmental manager

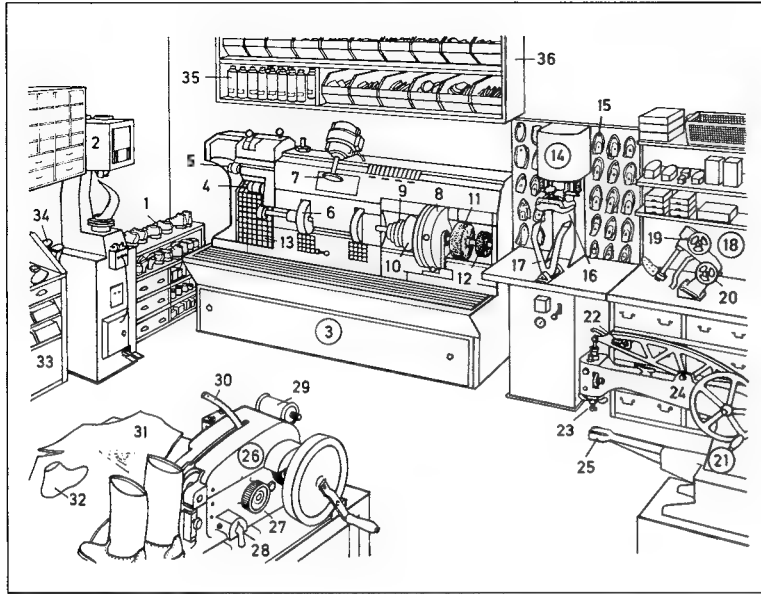

- | | |
|---|--|
| 1-68 shoemaker's workshop (bootmaker's workshop) | 22 power regulator (power control) |
| 1 finished (repaired) shoes | 23 foot |
| 2 auto-soling machine | 24 handwheel |
| 3 finishing machine | 25 arm |
| 4 heel trimmer | 26 sole stitcher (sole-stitching machine) |
| 5 sole trimmer | 27 foot bar lever |
| 6 scouring wheel | 28 feed adjustment (feed setting) |
| 7 naum keag | 29 bobbin (cotton bobbin) |
| 8 drive unit (drive wheel) | 30 thread guide (yarn guide) |
| 9 iron | 31 sole leather |
| 10 buffing wheel | 32 [wooden] last |
| 11 polishing brush | 33 workbench |
| 12 horsehair brush | 34 last |
| 13 extractor grid | 35 dye spray |
| 14 automatic sole press | 36 shelves for materials |
| 15 press attachment | |
| 16 pad | |
| 17 press bar | |
| 18 stretching machine | |
| 19 width adjustment | |
| 20 length adjustment | |
| 21 stitching machine | |

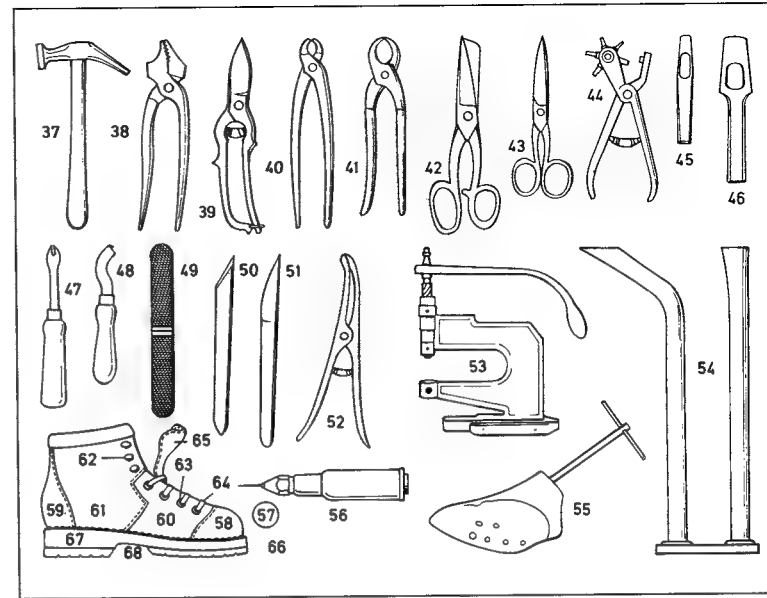

- | | |
|---|-------------------------------------|
| 37 shoemaker's hammer | 58 toecap |
| 38 shoemaker's pliers (welt pincers) | 59 counter |
| 39 sole-leather shears | 60 vamp |
| 40 small pincers (nippers) | 61 quarter |
| 41 large pincers (nippers) | 62 hook |
| 42 upper-leather shears | 63 eyelet |
| 43 scissors | 64 lace (shoelace, bootlace) |
| 44 revolving punch (rotary punch) | 65 tongue |
| 45 punch | 66 sole |
| 46 punch with handle | 67 heel |
| 47 nail puller | 68 shank (waist) |
| 48 welt cutter | |
| 49 shoemaker's rasp | |
| 50 cobbler's knife (shoemaker's knife) | |
| 51 skiving knife (skife knife, paring knife) | |
| 52 toecap remover | |
| 53 eyelet, hook, and press-stud setter | |
| 54 stand (with iron lasts) | |
| 55 width-setting tree | |
| 56 nail grip | |
| 57 boot | |

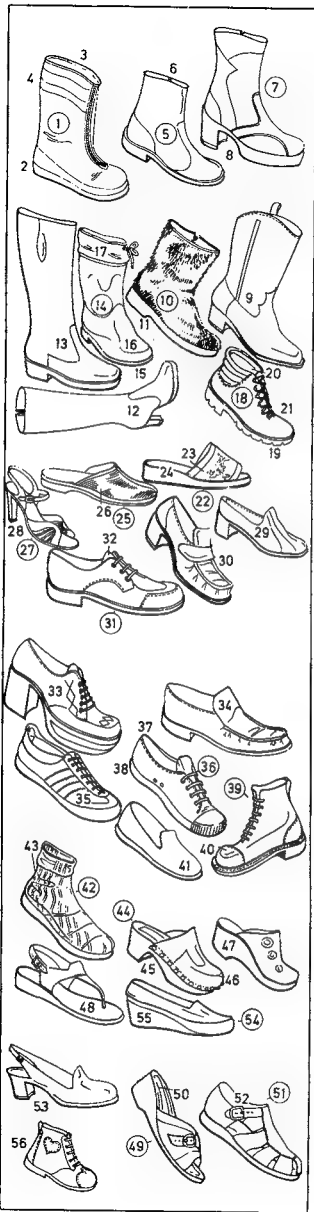

- 1 winter boot
- 2 PVC sole (plastic sole)
- 3 high-pile lining
- 4 nylon
- 5 men's boot
- 6 inside zip (*Am.* zipper)
- 7 men's high leg boot
- 8 platform sole (platform)
- 9 Western boot (cowboy boot)
- 10 pony-skin boot
- 11 cemented sole
- 12 ladies' boot
- 13 men's high leg boot
- 14 seamless PVC waterproof wellington boot
- 15 natural-colour (*Am.* natural-color) sole
- 16 toecap
- 17 tricot lining (knitwear lining)
- 18 hiking boot
- 19 grip sole
- 20 padded collar
- 21 tie fastening (lace fastening)
- 22 open-toe mule
- 23 terry upper
- 24 polo outsole
- 25 mule
- 26 corduroy upper
- 27 evening sandal (sandal court shoe)
- 28 high heel (stiletto heel)
- 29 court shoe (*Am.* pump)
- 30 moccasin
- 31 shoe, a tie shoe (laced shoe, Oxford shoe, *Am.* Oxford)
- 32 tongue
- 33 high-heeled shoe (shoe with raised heel)
- 34 casual
- 35 trainer (training shoe)
- 36 tennis shoe
- 37 counter (stiffening)
- 38 natural-colour (*Am.* natural-color) rubber sole
- 39 heavy-duty boot (*Am.* stogy, stogie)
- 40 toecap
- 41 slipper
- 42 woollen (*Am.* woollen) slip sock
- 43 knit stitch (knit)
- 44 clog
- 45 wooden sole
- 46 soft-leather upper
- 47 sabot
- 48 toe post sandal
- 49 ladies' sandal
- 50 surgical footbed (sock)
- 51 sandal
- 52 shoe buckle (buckle)
- 53 sling-back court shoe (*Am.* sling pump)
- 54 fabric court shoe
- 55 wedge heel
- 56 baby's first walking boot

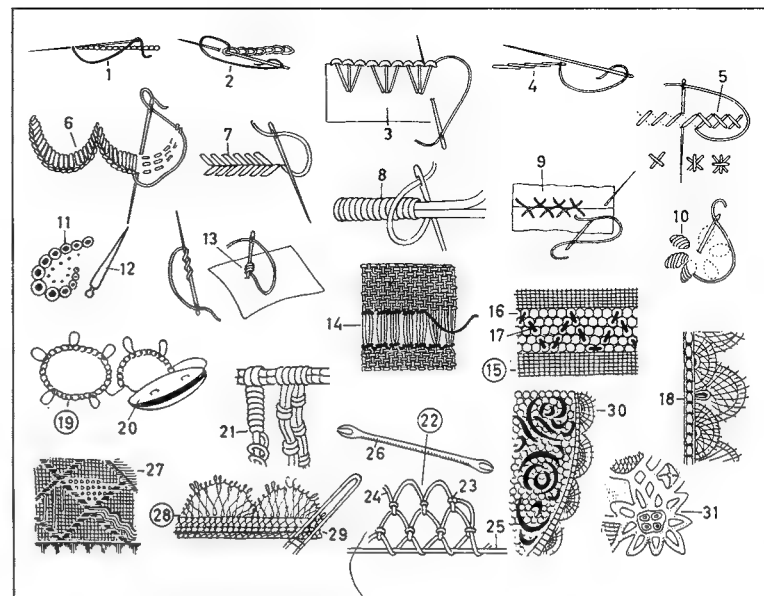

- | | |
|--|---|
| 1 backstitch seam | 19 tating |
| 2 chain stitch | 20 tating shuttle (shuttle) |
| 3 ornamental stitch | 21 knotted work (macramé) |
| 4 stem stitch | 22 filet (netting) |
| 5 cross stitch | 23 netting loop |
| 6 buttonhole stitch (button stitch) | 24 netting thread |
| 7 fishbone stitch | 25 mesh pin (mesh gauge) |
| 8 overcast stitch | 26 netting needle |
| 9 herringbone stitch (Russian stitch, Russian cross stitch) | 27 open work |
| 10 satin stitch (flat stitch) | 28 gimping (hairpin work) |
| 11 eyelet embroidery (broderie anglaise) | 29 gimping needle (hairpin) |
| 12 stiletto | 30 needlepoint lace (point lace, needlepoint); <i>kinds:</i> reticella lace, Venetian lace, Alençon lace; <i>sim.:</i> with metal thread: filigree work |
| 13 French knot (French dot, knotted stitch, twisted knot stitch) | 31 braid embroidery (braid work) |
| 14 hem stitch work | |
| 15 tulle work (tulle lace) | |
| 16 tulle background (net background) | |
| 17 darning stitch | |
| 18 pillow lace (bobbin lace, bone lace); <i>kinds:</i> Valenciennes, Brussels lace | |

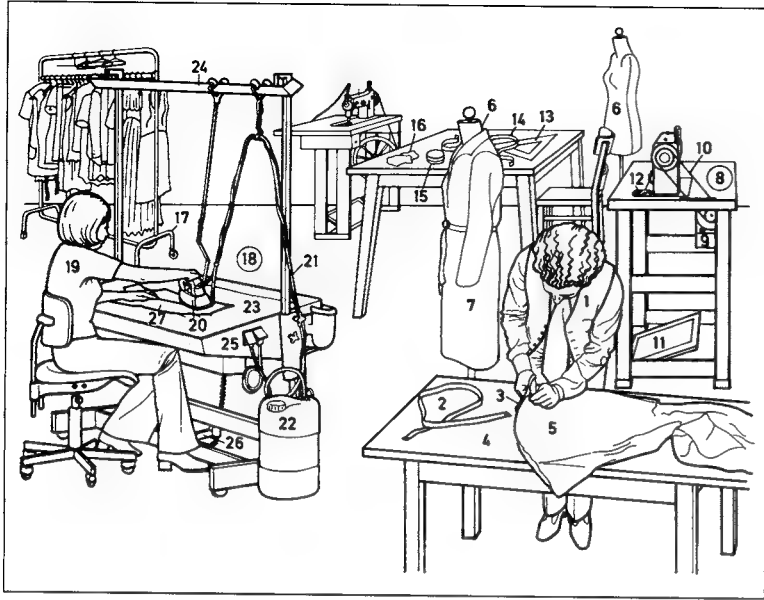
**1-27 dressmaker's workroom**

- | | |
|---|--|
| 1 dressmaker | 20 steam iron |
| 2 tape measure (measuring tape), a metre (<i>Am.</i> meter) tape measure | 21 water feed pipe |
| 3 cutting shears | 22 water container |
| 4 cutting table | 23 adjustable-tilt ironing surface |
| 5 model dress | 24 lift device for the iron |
| 6 dressmaker's model (dressmaker's dummy, dress form) | 25 steam extractor |
| 7 model coat | 26 foot switch controlling steam extraction |
| 8 sewing machine | 27 pressed non-woven woollen (<i>Am.</i> woolen) fabric |
| 9 drive motor | |
| 10 drive belt | |
| 11 treadle | |
| 12 sewing machine cotton (sewing machine thread) [on bobbin] | |
| 13 cutting template | |
| 14 seam binding | |
| 15 button box | |
| 16 remnant | |
| 17 movable clothes rack | |
| 18 hand-iron press | |
| 19 presser (ironer) | |

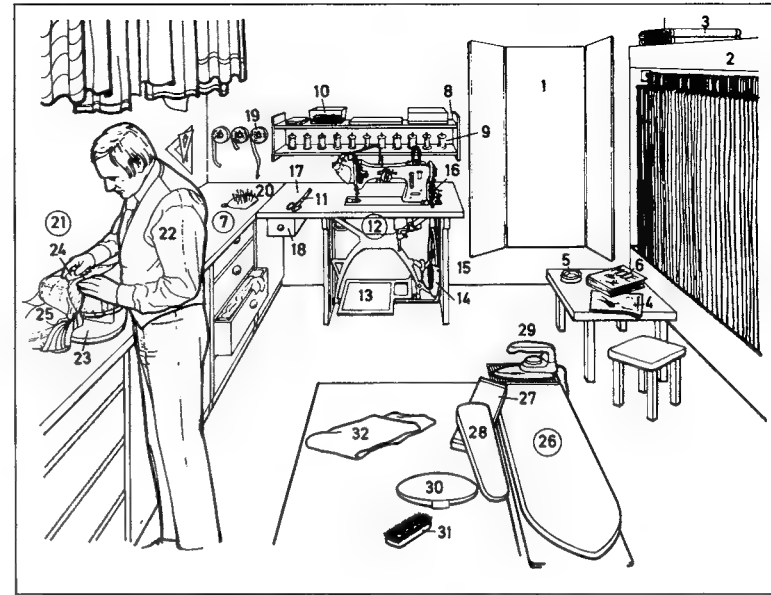
**1-32 tailor's workroom**

- | | |
|---|--------------------------------------|
| 1 triple mirror | 22 tailor |
| 2 lengths of material | 23 shaping pad |
| 3 suiting | 24 tailor's chalk (French chalk) |
| 4 fashion journal (fashion magazine) | 25 workpiece |
| 5 ashtray | 26 steam press (steam pressing unit) |
| 6 fashion catalogue | 27 swivel arm |
| 7 workbench | 28 pressing cushion (pressing pad) |
| 8 wall shelves (wall shelf unit) | 29 iron |
| 9 cotton reel | 30 hand-ironing pad |
| 10 small reels of sewing silk | 31 clothes brush |
| 11 hand shears | 32 pressing cloth |
| 12 combined electric and treadle sewing machine | |
| 13 treadle | |
| 14 dress guard | |
| 15 band wheel | |
| 16 bobbin thread | |
| 17 sewing machine table | |
| 18 sewing machine drawer | |
| 19 seam binding | |
| 20 pincushion | |
| 21 marking out | |

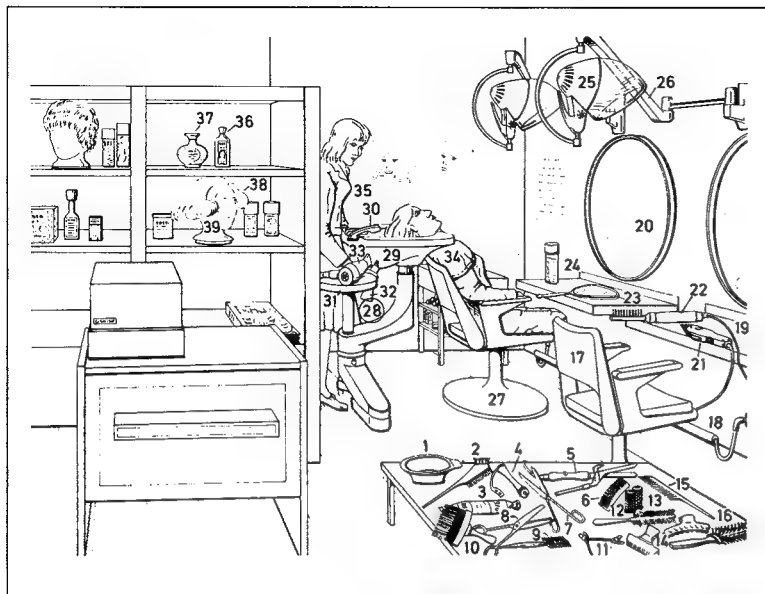

1-39 ladies' hairdressing salon and beauty salon (*Am.* beauty parlor, beauty shop)

1-16 hairdresser's tools

- 1 bowl containing bleach
- 2 detangling brush
- 3 bleach tube
- 4 curler [used in dyeing]
- 5 curling tongs (curling iron)
- 6 comb (back comb, side comb)
- 7 haircutting scissors
- 8 thinning scissors (*Am.* thinning shears)
- 9 thinning razor
- 10 hairbrush
- 11 hair clip
- 12 roller
- 13 curl brush
- 14 curl clip
- 15 dressing comb
- 16 stiff-bristle brush
- 17 adjustable hairdresser's chair
- 18 footrest
- 19 dressing table
- 20 salon mirror (mirror)
- 21 electric clippers
- 22 warm-air comb
- 23 hand mirror (hand glass)
- 24 hairspray (hair-fixing spray)
- 25 drier, a swivel-mounted drier
- 26 swivel arm of the drier
- 27 round base
- 28 shampoo unit
- 29 shampoo basin
- 30 hand spray (shampoo spray)
- 31 service tray
- 32 shampoo bottle
- 33 hair drier (hand hair drier, hand-held hair drier)
- 34 cape (gown)
- 35 hairdresser
- 36 perfume bottle
- 37 bottle of toilet water
- 38 wig
- 39 wig block

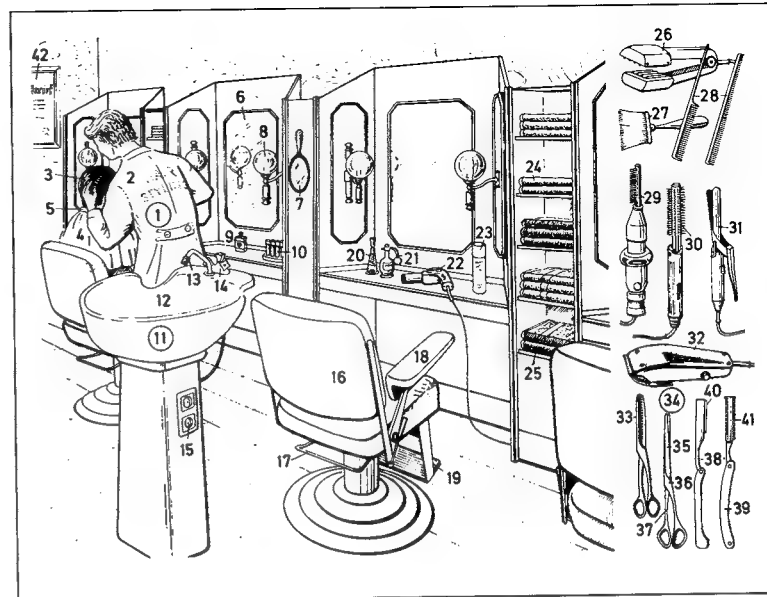

1-42 men's salon (men's hairdressing salon, barber's shop, *Am.* barber-shop)

- 1 hairdresser (barber)
- 2 overalls (hairdresser's overalls)
- 3 hairstyle (haircut)
- 4 cape (gown)
- 5 paper towel
- 6 salon mirror (mirror)
- 7 hand mirror (hand glass)
- 8 light
- 9 toilet water
- 10 hair tonic
- 11 shampoo unit
- 12 shampoo basin
- 13 hand spray (shampoo spray)
- 14 mixer tap (*Am.* mixing faucet)
- 15 sockets, e.g. for hair drier
- 16 adjustable hairdresser's chair (barber's chair)
- 17 height-adjuster bar (height adjuster)
- 18 armrest
- 19 footrest
- 20 shampoo
- 21 perfume spray
- 22 hair drier (hand hair drier, hand-held hair drier)
- 23 setting lotion in a spray can
- 24 hand towels for drying hair
- 25 towels for face compresses
- 26 crimping iron
- 27 neck brush
- 28 dressing comb
- 29 warm-air comb
- 30 warm-air brush
- 31 curling tongs (hair curler, curling iron)
- 32 electric clippers
- 33 thinning scissors (*Am.* thinning shears)
- 34 haircutting scissors; *sim.*: styling scissors
- 35 scissor-blade
- 36 pivot
- 37 handle
- 38 open razor (straight razor)
- 39 razor handle
- 40 edge (cutting edge, razor's edge, razor's cutting edge)
- 41 thinning razor
- 42 diploma

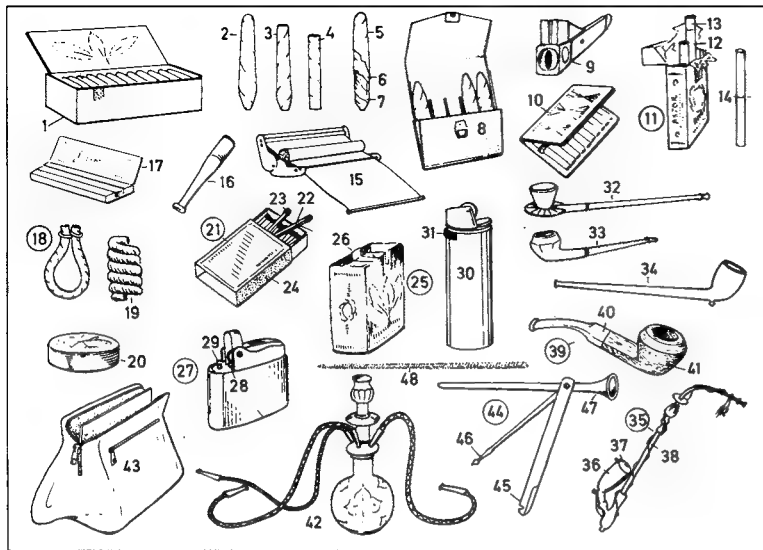

- | | |
|---|--|
| 1 cigar box | 26 revenue stamp |
| 2 cigar; <i>kinds</i> : Havana cigar (Havana), Brazilian cigar, Sumatra cigar | 27 petrol cigarette lighter (petrol lighter) |
| 3 cigarillo | 28 flint |
| 4 cheroot | 29 wick |
| 5 wrapper | 30 gas cigarette lighter (gas lighter), a disposable lighter |
| 6 binder | 31 flame regulator |
| 7 filler | 32 chibonk (chibonque) |
| 8 cigar case | 33 short pipe |
| 9 cigar cutter | 34 clay pipe (Dutch pipe) |
| 10 cigarette case | 35 long pipe |
| 11 cigarette packet (<i>Am. pack</i>) | 36 pipe bowl (bowl) |
| 12 cigarette, a filter-tipped cigarette | 37 bowl lid |
| 13 cigarette tip; <i>kinds</i> : cork tip, gold tip | 38 pipe stem (stem) |
| 14 Russian cigarette | 39 briar pipe |
| 15 cigarette roller | 40 mouthpiece |
| 16 cigarette holder | 41 sand-blast finished or polished briar grain |
| 17 packet of cigarette papers | 42 hookah (narghile, narghileh), a water pipe |
| 18 pigtail (twist of tobacco) | 43 tobacco pouch |
| 19 chewing tobacco; <i>a piece</i> : plug (quid, chew) | 44 smoker's companion |
| 20 snuff box, containing snuff | 45 pipe scraper |
| 21 matchbox | 46 pipe cleaner |
| 22 match | 47 tobacco presser |
| 23 head (match head) | 48 pipe cleaner |
| 24 striking surface | |
| 25 packet of tobacco; <i>kinds</i> : fine cut, shag, navy plug | |

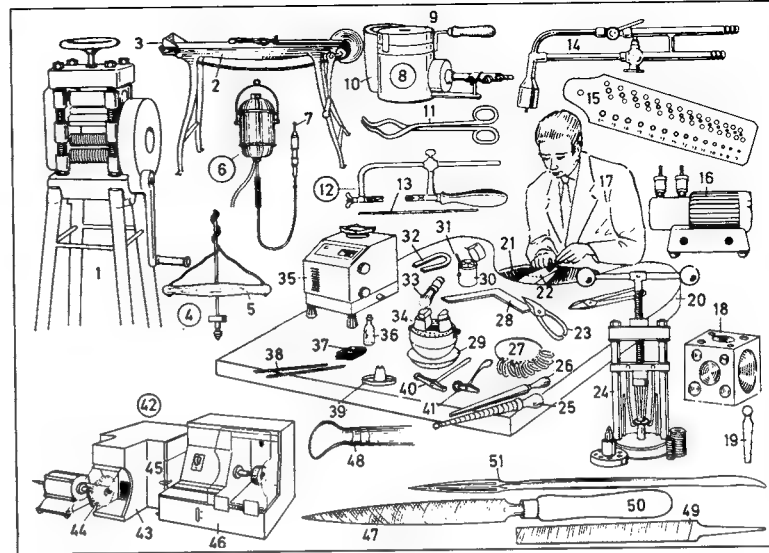

- | | |
|---|---|
| 1 wire and sheet roller | 27 ring gauge (<i>Am. gage</i>) |
| 2 drawbench (drawing bench) | 28 steel set-square |
| 3 wire (gold or silver wire) | 29 (circular) leather pad |
| 4 archimedes drill (drill) | 30 box of punches |
| 5 crossbar | 31 punch |
| 6 suspended (pendant) electric drilling machine | 32 magnet |
| 7 spherical cutter (cherry) | 33 bench brush |
| 8 melting pot | 34 engraving ball (joint vice, clamp) |
| 9 fireclay top | 35 gold and silver balance (assay balance), a precision balance |
| 10 graphite crucible | 36 soldering flux (flux) |
| 11 crucible tongs | 37 charcoal block |
| 12 piercing saw (jig saw) | 38 stick of solder |
| 13 piercing saw blade | 39 soldering borax |
| 14 soldering gun | 40 shaping hammer |
| 15 thread tapper | 41 chasing (enchasing) hammer |
| 16 blast burner (blast lamp) for soldering | 42 polishing and burnishing machine |
| 17 goldsmith | 43 dust exhauster (vacuum cleaner) |
| 18 swage block | 44 polishing wheel |
| 19 punch | 45 dust collector (dust catcher) |
| 20 workbench (bench) | 46 buffing machine |
| 21 bench apron | 47 round file |
| 22 needle file | 48 bloodstone (haematite, hematite) |
| 23 metal shears | 49 flat file |
| 24 wedding ring sizing machine | 50 file handle |
| 25 ring gauge (<i>Am. gage</i>) | 51 polishing iron (burnisher) |
| 26 ring-rounding tool | |

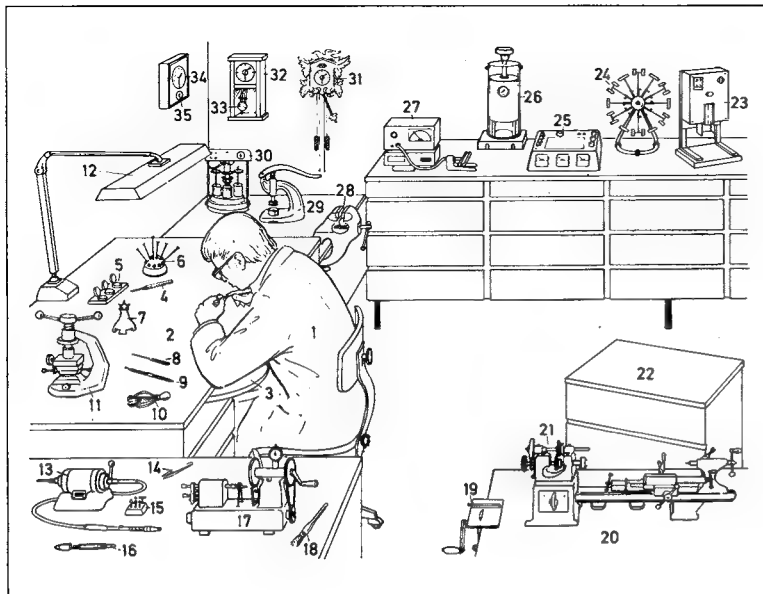

- | | |
|---|---|
| 1 watchmaker; <i>also</i> : clockmaker | 21 drive-belt gear |
| 2 workbench | 22 workshop trolley for spare parts |
| 3 armrest | 23 ultrasonic cleaner |
| 4 oiler | 24 rotating watch-testing machine for automatic watches |
| 5 oil stand | 25 watch-timing machine for electronic components |
| 6 set of screwdrivers | 26 testing device for waterproof watches |
| 7 clockmaker's anvil | 27 electronic timing machine |
| 8 broach, a reamer | 28 vice (<i>Am.</i> vise) |
| 9 spring pin tool | 29 watchglass-fitting tool for armoured (<i>Am.</i> armored) glasses |
| 10 hand-removing tool | 30 [automatic] cleaning machine for conventional cleaning |
| 11 watchglass-fitting tool | 31 cuckoo clock (Black Forest clock) |
| 12 workbench lamp, a multi-purpose lamp | 32 wall clock (regulator) |
| 13 multi-purpose motor | 33 compensation pendulum |
| 14 tweezers | 34 kitchen clock |
| 15 polishing machine attachments | 35 timer |
| 16 pin vice (pin holder) | |
| 17 burnisher, for burnishing, polishing, and shortening of spindles | |
| 18 dust brush | |
| 19 cutter for metal watch straps | |
| 20 precision bench lathe (watchmaker's lathe) | |

- 1 electronic wristwatch
- 2 digital display (a light-emitting diode (LED) display; *also*: a liquid crystal display, LCD)
- 3 hour and minute button (on 6, also for setting the analogue (*Am.* analog) display)
- 4 date and second button
- 5 strap (watch strap)
- 6 multifunction electronic watch
- 7 analogue (*Am.* analog) display
- 8 alarm button
- 9 stopwatch button
- 10 rotating bezel (time-lapse indicator ring)
- 11 calendar clock (alarm clock)
- 12 digital display with flip-over numerals
- 13 alarm indicator
- 14 stop button
- 15 forward and backward wind knob
- 16 grandfather clock
- 17 face
- 18 clock case
- 19 pendulum
- 20 striking weight
- 21 time weight
- 22 sundial
- 23 hourglass (egg timer)
- 24-35 components of an automatic watch (automatic wristwatch, self-winding watch)
 - 24 weight (rotor)
 - 25 stone (jewel, jewelled bearing) a synthetic ruby
 - 26 click
 - 27 click wheel
 - 28 clockwork (clockwork mechanism)
 - 29 bottom train plate
 - 30 spring barrel
 - 31 balance wheel
 - 32 escape wheel
 - 33 crown wheel
 - 34 winding crown
 - 35 drive mechanism
 - 36 principle of the electronic quartz watch
 - 37 quartz
 - 38 power source (a button cell)
 - 39 hour hand
 - 40 minute hand
 - 41 wheels
 - 42 stepping motor (stepper motor)
 - 43 frequency divider (integrated circuit)
 - 44 decoder

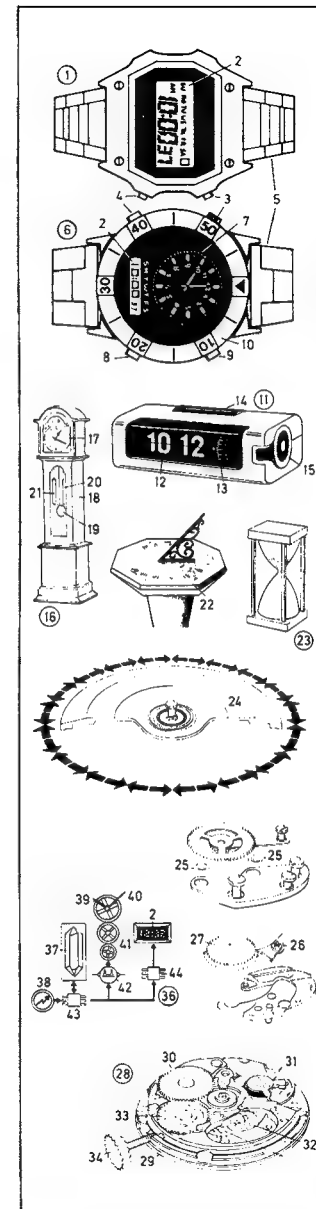

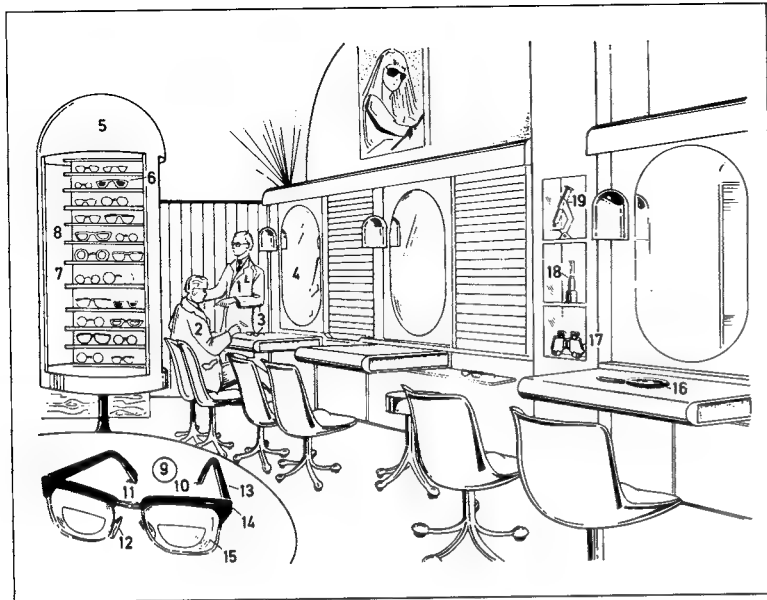
**1-19 sales premises****1-4 spectacle fitting**

- 1 optician
- 2 customer
- 3 trial frame
- 4 mirror
- 5 stand with spectacle frames (display of frames, range of spectacles)
- 6 sunglasses (sun spectacles)
- 7 metal frame
- 8 tortoiseshell frame (shell frame)
- 9 spectacles (glasses)

10-14 spectacle frame

- 10 fitting (mount) of the frame
- 11 bridge
- 12 pad bridge
- 13 side
- 14 side joint
- 15 spectacle lens, a bifocal lens
- 16 hand mirror (hand glass)
- 17 binoculars
- 18 monocular telescope (tube)
- 19 microscope

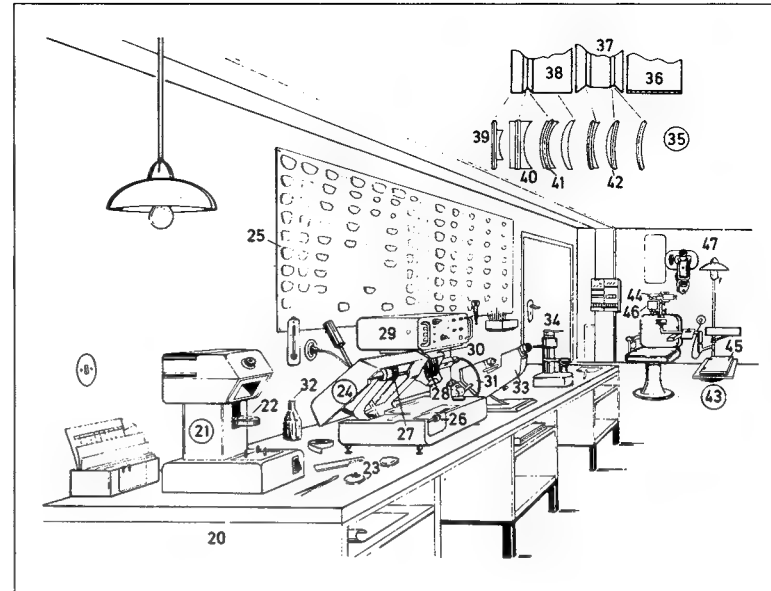
**20-47 optician's workshop**

- 20 workbench
- 21 universal centring (centering) apparatus
- 22 centring (centering) suction holder
- 23 sucker
- 24 edging machine
- 25 formers for the lens edging machine
- 26 inserted former
- 27 rotating printer
- 28 abrasive wheel combination
- 29 control unit
- 30 machine part
- 31 cooling water pipe
- 32 cleaning fluid
- 33 focimeter (vertex refractometer)
- 34 metal-blocking device
- 35 abrasive wheel combination and forms of edging
- 36 roughing wheel for preliminary surfacing
- 37 fining lap for positive and negative lens surfaces
- 38 fining lap for special and flat lenses
- 39 plano-concave lens with a flat surface
- 40 plano-concave lens with a special surface
- 41 concave and convex lens with a special surface
- 42 convex and concave lens with a special surface
- 43 ophthalmic test stand
- 44 phoropter with ophthalmometer and optometer (refractometer)
- 45 trial lens case
- 46 collimator
- 47 acuity projector

- 1 laboratory and research microscope, *Leitz system*
- 2 stand
- 3 base
- 4 coarse adjustment
- 5 fine adjustment
- 6 illumination beam path (illumination path)
- 7 illumination optics
- 8 condenser
- 9 microscope (microscopic, object) stage
- 10 mechanical stage
- 11 objective turret (revolving nose-piece)
- 12 binocular head
- 13 beam-splitting prisms
- 14 transmitted-light microscope with camera and polarizer, *Zeiss system*
- 15 stage base
- 16 aperture-stop slide
- 17 universal stage
- 18 lens panel
- 19 polarizing filter
- 20 camera
- 21 focusing screen
- 22 discussion tube arrangement
- 23 wide-field metallurgical microscope, a reflected-light microscope (microscope for reflected light)
- 24 matt screen (ground glass screen, projection screen)
- 25 large-format camera
- 26 miniature camera
- 27 base plate
- 28 lamphouse
- 29 mechanical stage
- 30 objective turret (revolving nose-piece)
- 31 surgical microscope
- 32 pillar stand
- 33 field illumination
- 34 photomicroscope
- 35 miniature film cassette
- 36 photomicrographic camera attachment for large-format or television camera
- 37 surface-finish microscope
- 38 light section tube

- 39 rack and pinion
- 40 zoom stereomicroscope
- 41 zoom lens
- 42 dust counter
- 43 measurement chamber
- 44 data output
- 45 analogue (*Am. analog*) output
- 46 measurement range selector
- 47 digital display (digital readout)
- 48 dipping refractometer for examining food
- 49 microscopic photometer
- 50 photometric light source
- 51 measuring device (photomultiplier, multiplier phototube)
- 52 light source for survey illumination
- 53 remote electronics
- 54 universal wide-field microscope
- 55 adapter for camera or projector attachment
- 56 eyepiece focusing knob
- 57 filter pick-up
- 58 handrest
- 59 lamphouse for incident (vertical) illumination
- 60 lamphouse connector for transillumination
- 61 wide-field stereomicroscope
- 62 interchangeable lenses (objectives)
- 63 incident (vertical) illumination (incident top lighting)
- 64 fully automatic microscope camera, a camera with photomicro mount adapter
- 65 film cassette
- 66 universal condenser for research microscope 1
- 67 universal-type measuring machine for photogrammetry (photo-theodolite)
- 68 photogrammetric camera
- 69 motor-driven level, a compensator level
- 70 electro-optical distance-measuring instrument
- 71 stereometric camera
- 72 horizontal base
- 73 one-second theodolite

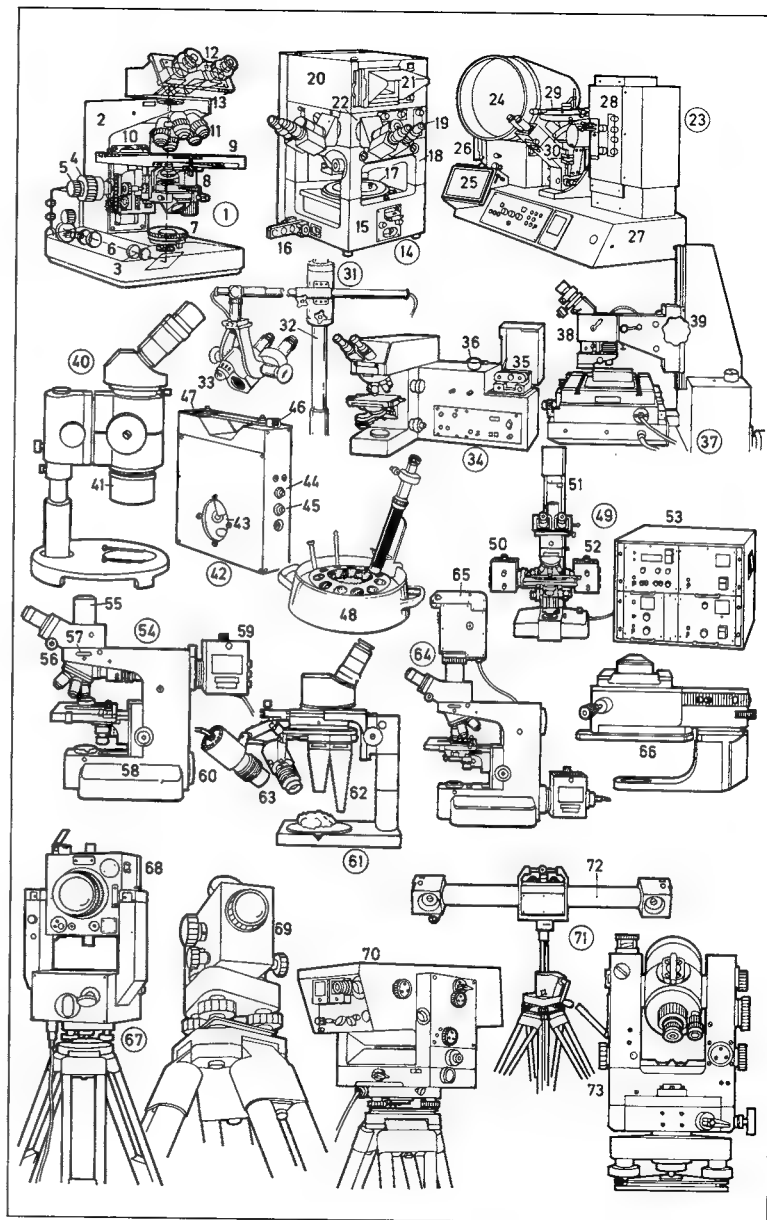

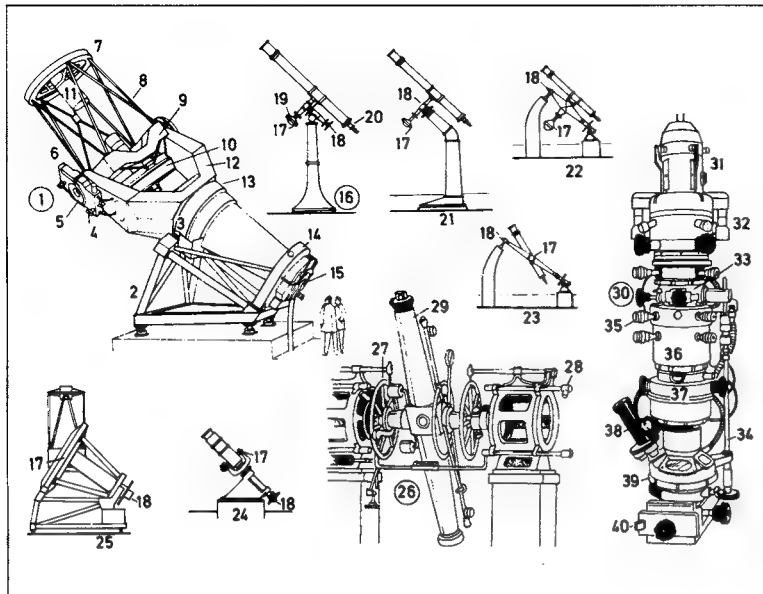

- | | |
|---|--|
| 1 2.2 m reflecting telescope (reflector) | 22 English-type axis mounting (axis mount) |
| 2 pedestal (base) | 23 English-type yoke mounting (yoke mount) |
| 3 axial-radial bearing | 24 fork mounting (fork mount) |
| 4 declination gear | 25 horseshoe mounting (horseshoe mount) |
| 5 declination axis | 26 meridian circle |
| 6 declination bearing | 27 divided circle (graduated circle) |
| 7 front ring | 28 reading microscope |
| 8 tube (body tube) | 29 meridian telescope |
| 9 tube centre (<i>Am.</i> center) section | 30 electron microscope |
| 10 primary mirror (main mirror) | 31-39 microscope tube (microscope body, body tube) |
| 11 secondary mirror (deviation mirror, corrector plate) | 31 electron gun |
| 12 fork mounting (fork) | 32 condensers |
| 13 cover | 33 specimen insertion air lock |
| 14 guide bearing | 34 control for the specimen stage adjustment |
| 15 main drive unit of the polar axis | 35 control for the objective apertures |
| 16-25 telescope mountings (telescope mounts) | 36 objective lens |
| 16 refractor (refracting telescope) on a German-type mounting | 37 intermediate image screen |
| 17 declination axis | 38 telescope magnifier |
| 18 polar axis | 39 final image tube |
| 19 counterweight (counterpoise) | 40 photographic chamber for film and plate magazines |
| 20 eyepiece | |
| 21 knee mounting with a bent column | |

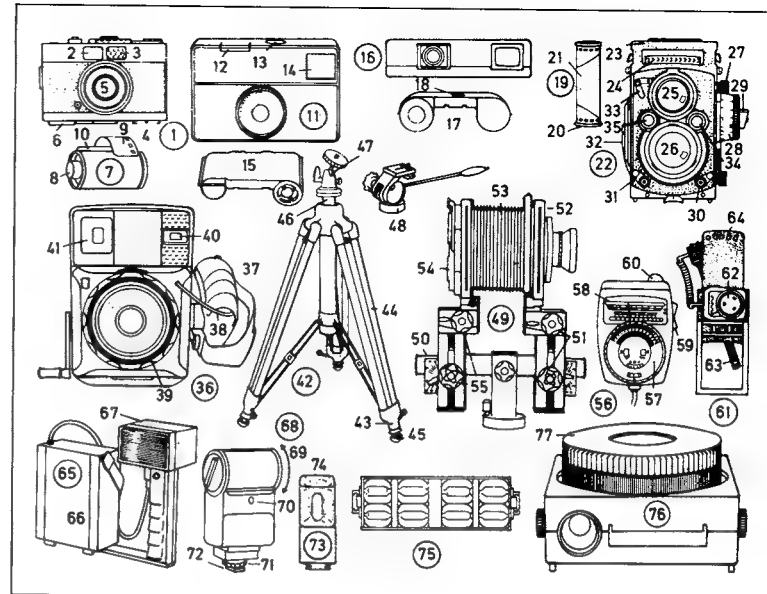

- | | | |
|---|---|---|
| 1 miniature camera (35 mm camera) | 25 viewing lens | 53 bellows |
| 2 viewfinder eyepiece | 26 object lens | 54 camera back |
| 3 meter cell | 27 spool knob | 55 back standard adjustment |
| 4 accessory shoe | 28 distance setting (focus setting) | 56 hand-held exposure meter (exposure meter) |
| 5 flush lens | 29 exposure meter using needle-matching system | 57 calculator dial |
| 6 rewind handle (rewind, rewind crank) | 30 flash contact | 58 scales (indicator scales) with indicator needle (pointer) |
| 7 miniature film cassette (135 film cassette, 35 mm cassette) | 31 shutter release | 59 range switch (high/low range selector) |
| 8 film spool | 32 film transport (film advance, film wind) | 60 diffuser for incident light measurement |
| 9 film with leader and perforations | 33 flash switch | 61 probe exposure meter for large-format cameras |
| 10 cassette slit (cassette exit slot) | 34 aperture-setting control | 62 meter |
| 11 cartridge-loading camera | 35 shutter speed control | 63 probe |
| 12 shutter release (shutter release button) | 36 large-format hand camera (press camera) | 64 dark slide |
| 13 flash cube contact | 37 grip (handgrip) | 65 battery-portable electronic flash (battery-portable electronic flash unit) |
| 14 rectangular viewfinder | 38 cable release | 66 power pack unit (battery) |
| 15 126 cartridge (instamatic cartridge) | 39 distance-setting ring (focusing ring) | 67 flash head |
| 16 pocket camera (subminiature camera) | 40 rangefinder window | 68 single-unit electronic flash (flashgun) |
| 17 110 cartridge (subminiature cartridge) | 41 multiple-frame viewfinder (universal viewfinder) | 69 swivel-mounted reflector |
| 18 film window | 42 tripod | 70 photodiode |
| 19 120 rollfilm | 43 tripod leg | 71 foot |
| 20 rollfilm spool | 44 tubular leg | 72 hot-shoe contact |
| 21 backing paper | 45 rubber foot | 73 flash cube unit |
| 22 twin-lens reflex camera | 46 central column | 74 flash cube |
| 23 folding viewfinder hood (focusing hood) | 47 ball and socket head | 75 flash bar (AGFA) |
| 24 meter cell | 48 cine camera pan and tilt head | 76 slide projector |
| | 49 large-format folding camera | 77 rotary magazine |
| | 50 optical bench | |
| | 51 standard adjustment | |
| | 52 lens standard | |

- 1-24 system camera** (fully automatic miniature single-lens reflex camera)
- 1 main switch
 - 2 function adjustment button (to set exposure adjustment value, drive mode, and focus area)
 - 3 exposure mode button
 - 4 accessory shoe
 - 5 program reset button
 - 6 data panel (data monitor, data display)
 - 7 card on/off key
 - 8 function selector key
 - 9 chip program card
 - 10 card door
 - 11 card window
 - 12 battery chamber
 - 13 remote control terminal
 - 14 shutter release (shutter release button)
 - 15 autofocus (AF) illuminator and self-timer light
 - 16 manual shutter control [up/down control]
 - 17 reflex mirror
 - 18 autofocus sensor, a CCD image converter (image sensor)
 - 19 bayonet mounting ring
 - 20 aperture setting button
 - 21 lens release
 - 22 focus-mode switch (to switch to manual focusing)
 - 23 autofocus zoom lens, a $\times 3$ zoom lens (35-105 mm)
 - 24 aperture and autofocus contacts
- 25-35 viewfinder screen** (focusing screen, matt screen), a micro-honeycombed focusing screen
- 25 flash-on signal
 - 26 flash-ready signal
 - 27 focus signals
 - 28 wide focus area
 - 29 shutter speed display
 - 30 manual-exposure compensation-value indicator
 - 31 aperture or exposure adjustment indicator
 - 32 spot metering indicator
 - 33 spot metering area
 - 34 centre focus area
 - 35 focus area indicator
- 36-42 LCD data panel** (data monitor)
- 36 program exposure-mode indicator

- 37 frame counter
 - 38 function indicators
 - 39 aperture or exposure adjustment indicator
 - 40 shutter speed or film speed (film sensitivity) indicator
 - 41 film transport indicator
 - 42 function pointer
 - 43 interchangeable lenses (autofocus lenses, AF lenses)
 - 44 fisheye lens (fisheye)
 - 45 wide-angle lens (short focal-length lens)
 - 46 standard lens
 - 47 medium focal-length lens
 - 48 telephoto lens (long focal-length lens), a zoom lens (variable focus lens, varifocal lens)
 - 49 long-focus lens
 - 50 mirror lens
 - 51 tele converter
 - 52 data back
 - 53 ten-metre (*Am.* ten-meter) film back (magazine back)
- 54-74 accessories for close-up and macro shots**
- 54 extension tube
 - 55 adapter ring
 - 56 reversing ring
 - 57 lens in retrofocus position
 - 58 bellows unit (extension bellows, close-up bellows attachment)
 - 59 focusing stage
 - 60 slide-copying attachment
 - 61 slide-copying adapter
 - 62 cable release
 - 63 copying stand (copy stand)
 - 64 arm of the copying stand (copy stand)
 - 65 rifle grip
 - 66 table(-top) tripod (mini tripod)
 - 67 ever-ready case
 - 68 lens case
 - 69 soft-leather lens pouch
 - 70 camera bag, of metallic construction: aluminium (*Am.* aluminum) case
 - 71 film container
 - 72 filter case
 - 73 second body
 - 74 ring flash for macro shots

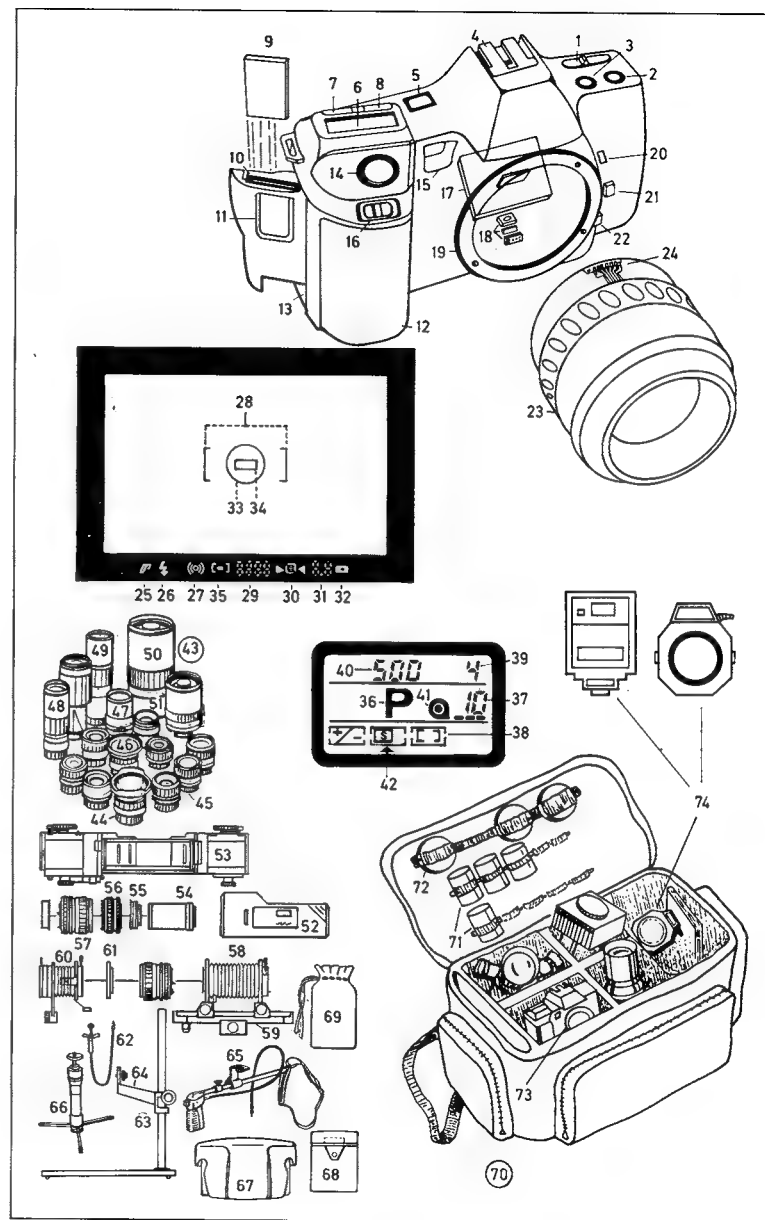

1-60 darkroom equipment

- 1 developing tank
- 2 spiral (developing spiral, tank reel)
- 3 multi-unit developing tank
- 4 multi-unit tank spiral
- 5 daylight-loading tank
- 6 loading chamber
- 7 film transport handle
- 8 developing tank thermometer
- 9 collapsible bottle for developing solution
- 10 chemical bottles for first developer, stop bath, colour developer, bleach-hardener, stabilizer
- 11 measuring cylinders
- 12 funnel
- 13 tray thermometer (dish thermometer)
- 14 film clip
- 15 wash tank (washer)
- 16 water supply pipe
- 17 water outlet pipe
- 18 laboratory timer (timer)
- 19 automatic film agitator
- 20 developing tank
- 21 darkroom lamp (safelight)
- 22 filter screen
- 23 film drier (drying cabinet)
- 24 exposure timer
- 25 developing dish (developing tray)
- 26 enlarger
- 27 baseboard
- 28 angled column
- 29 lamphouse (lamp housing)
- 30 negative carrier
- 31 bellows
- 32 lens
- 33 friction drive for fine adjustment
- 34 height adjustment (scale adjustment)
- 35 masking frame (easel)
- 36 colour (*Am. color*) analyser
- 37 colour (*Am. color*) analyser lamp
- 38 probe lead
- 39 exposure time balancing knob
- 40 colour (*Am. color*) enlarger
- 41 enlarger head

- 42 column
- 43-45 colour-mixing (*Am. color-mixing*) knob
- 43 magenta filter adjustment (minus green filter adjustment)
- 44 yellow filter adjustment (minus blue filter adjustment)
- 45 cyan filter adjustment (minus red filter adjustment)
- 46 red swing filter
- 47 print tongs
- 48 processing drum
- 49 squeegee
- 50 range (assortment) of papers
- 51 colour (*Am. color*) printing paper, a packet of photographic printing paper
- 52 colour (*Am. color*) chemicals (colour processing chemicals)
- 53 enlarging meter (enlarging photometer)
- 54 adjusting knob with paper speed scale
- 55 probe
- 56 semi-automatic thermostatically controlled developing dish
- 57 rapid print drier (heated print drier)
- 58 glazing sheet
- 59 pressure cloth
- 60 automatic processor (machine processor)

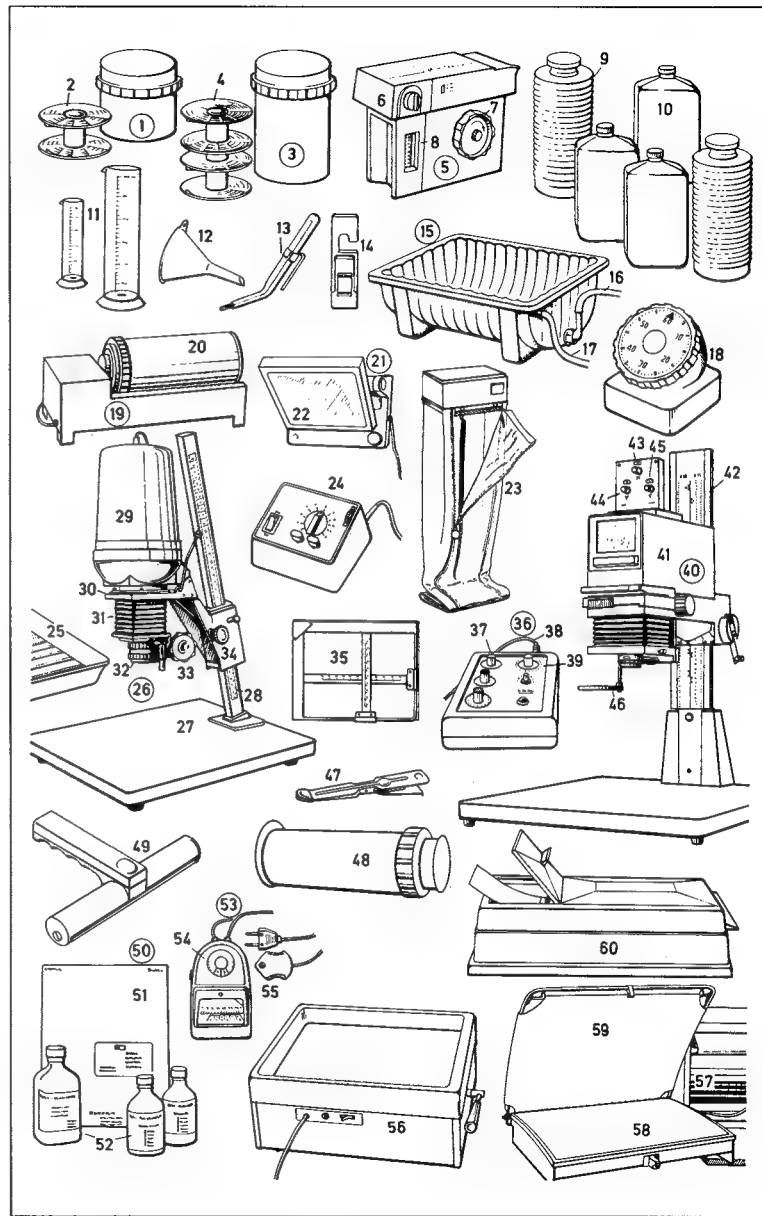

- 1 cine camera, ■ Super-8 sound camera
- 2 interchangeable zoom lens (variable focus lens, varifocal lens)
- 3 distance setting (focus setting) and manual focal length setting
- 4 aperture ring (aperture-setting ring, aperture control ring) for manual aperture setting
- 5 handgrip with battery chamber
- 6 shutter release with cable release socket
- 7 pilot tone or pulse generator socket for the sound recording equipment (with the dual film-tape system)
- 8 sound connecting cord for microphone or external sound source (in single-system recording)
- 9 remote control socket (remote control jack)
- 10 headphone socket (*sim.*: earphone socket)
- 11 autofocus override switch
- 12 filming speed selector
- 13 sound recording selector switch for automatic or manual operation
- 14 eyepiece with eyecup
- 15 diopter control ring (dioptric adjustment ring)
- 16 recording level control (audio level control, recording sensitivity selector)
- 17 manual/automatic exposure control switch
- 18 film speed setting
- 19 power zooming arrangement
- 20 automatic aperture control
- 21 sound track system
- 22 sound camera
- 23 telescopic microphone boom
- 24 microphone
- 25 microphone connecting lead (microphone connecting cord)
- 26 mixing console (mixing desk, mixer)
- 27 inputs from various sound sources
- 28 output to camera
- 29 Super-8 sound film cartridge
- 30 film gate of the cartridge
- 31 feed spool
- 32 take-up spool
- 33 recording head (sound head)
- 34 transport roller (capstan)
- 35 rubber pinch roller (capstan idler)
- 36 guide step (guide notch)
- 37 exposure meter control step
- 38 conversion filter step (colour, *Am. color*, conversion filter step)
- 39 single-8 cassette
- 40 film gate opening
- 41 unexposed film
- 42 exposed film
- 43 16 mm camera
- 44 reflex finder (through-the-lens reflex finder)
- 45 magazine
- 46-49 lens head
- 46 lens turret (turret head)
- 47 telephoto lens

- 48 wide-angle lens
- 49 normal lens (standard lens)
- 50 winding handle
- 51 compact Super-8 camera
- 52 footage counter
- 53 macro zoom lens
- 54 zooming lever
- 55 macro lens attachment (close-up lens)
- 56 macro frame (mount for small originals)
- 57 underwater housing (underwater case)
- 58 direct-vision frame finder
- 59 measuring rod
- 60 stabilizing wing
- 61 grip (handgrip)
- 62 locking bolt
- 63 control lever (operating lever)
- 64 porthole
- 65 synchronization start (sync start)
- 66 professional press-type camera
- 67 cameraman
- 68 camera assistant (sound assistant)
- 69 handclap marking sync start
- 70 dual film-tape recording using a tape recorder
- 71 pulse-generating camera
- 72 pulse cable
- 73 cassette recorder
- 74 microphone
- 75 dual film-tape reproduction
- 76 tape cassette
- 77 synchronization unit
- 78 cine projector
- 79 film feed spool
- 80 take-up reel (take-up spool), an automatic take-up reel (take-up spool)
- 81 sound projector
- 82 sound film with magnetic stripe (sound track, track)
- 83 automatic-threading button
- 84 trick button
- 85 volume control
- 86 reset button
- 87 fast and slow motion switch
- 88 forward, reverse, and still projection switch
- 89 splicer for wet splices
- 90 hinged clamping plate
- 91 film viewer (animated viewer editor)
- 92 foldaway reel arm
- 93 rewind handle (rewinder)
- 94 viewing screen
- 95 film perforator (film marker)
- 96 six-turntable film and sound cutting table (editing table, cutting bench, animated sound editor)
- 97 monitor
- 98 control buttons (control well)
- 99 film turntable
- 100 first sound turntable, e.g. for live sound
- 101 second sound turntable for post-sync sound
- 102 film and tape synchronizing head

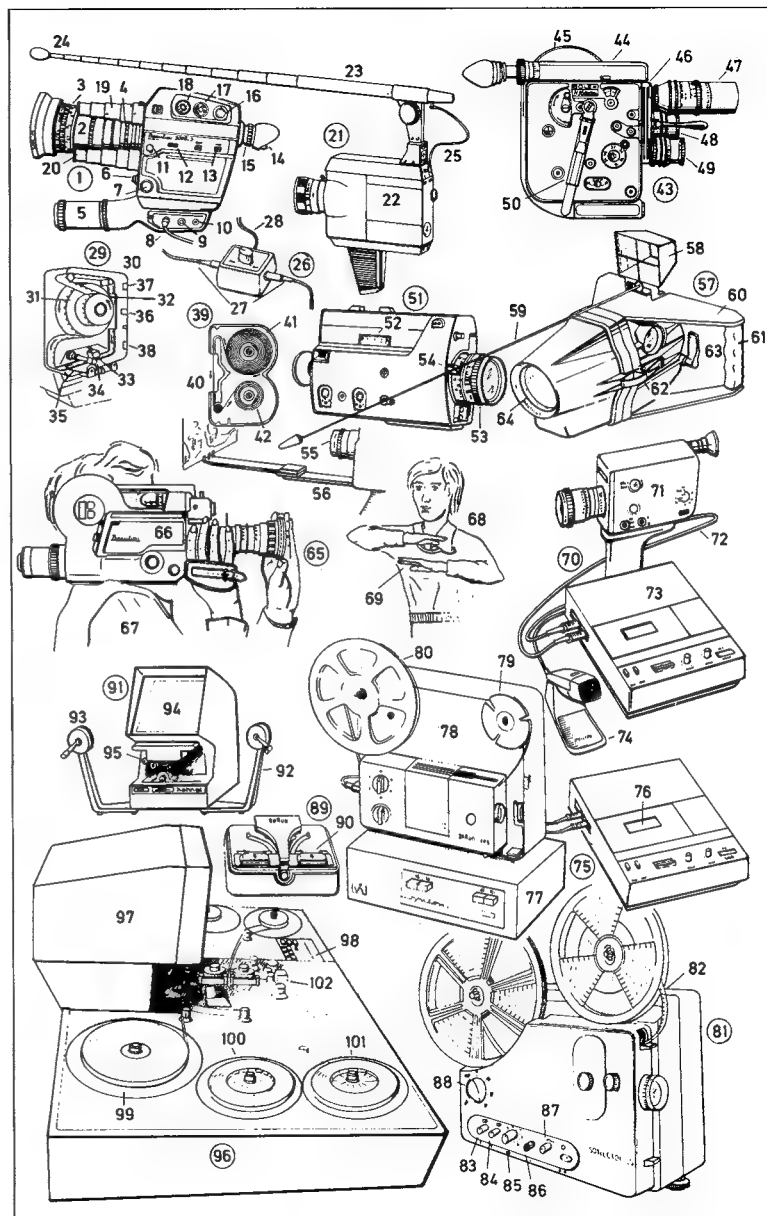

- 1-49 carcass (carcass, fabric) [house construction, carcassing]
 1 basement of tamped (rammed) concrete
 2 concrete base course
 3 cellar window (basement window)
 4 outside cellar steps
 5 utility room window
 6 utility room door
 7 ground floor (*Am.* first floor)
 8 brick wall
 9 lintel (window head)
 10 reveal
 11 jamb
 12 window ledge (window sill)
 13 reinforced concrete lintel
 14 upper floor (first floor, *Am.* second floor)
 15 hollow-block wall
 16 concrete floor
 17 work platform (working platform)
 18 bricklayer (*Am.* brickmason)
 19 bricklayer's labourer (*Am.* laborer); *also:* builder's labourer
 20 mortar trough
 21 chimney
 22 cover (boards) for the staircase
 23 scaffold pole (scaffold standard)
 24 platform railing
 25 angle brace (angle tie) in the scaffold
 26 ledger
 27 putlog (putlock)
 28 plank platform (board platform)
 29 guard board
 30 scaffolding joint with chain or lashing or whip or bond
 31 builder's hoist
 32 mixer operator
 33 concrete mixer, a gravity mixer
 34 mixing drum
 35 feeder skip
 36 concrete aggregate [sand and gravel]
 37 wheelbarrow
 38 hose (hosepipe)
 39 mortar pan (mortar trough, mortar tub)
 40 stack of bricks
 41 stacked shutter boards (lining boards)
 42 ladder
 43 bag of cement
 44 site fence, a timber fence
 45 signboard (billboard)
 46 removable gate
 47 contractors' name plates
 48 site hut (site office)
 49 building site latrine
 50-57 bricklayer's (*Am.* brickmason's) tools
 50 plumb bob (plummet)
 51 thick lead pencil
 52 trowel
 53 bricklayer's (*Am.* brickmason's) hammer (brick hammer)
 54 mallet
 55 spirit level
 56 laying-on trowel
 57 float
 58-68 masonry bonds
 58 brick (standard brick)
 59 stretching bond
 60 heading bond
 61 racking (raking) back
 62 English bond
 63 stretching course
 64 heading course
 65 English cross bond (Saint Andrew's cross bond)
 66 chimney bond
 67 first course
 68 second course
 69-82 excavation
 69 profile (*Am.* batterboard) [fixed on edge at the corner]
 70 intersection of strings
 71 plumb bob (plummet)
 72 excavation side
 73 upper edge board
 74 lower edge board
 75 foundation trench
 76 navy (*Am.* excavator)
 77 conveyor belt (conveyor)
 78 excavated earth
 79 plank roadway
 80 tree guard
 81 mechanical shovel (excavator)
 82 shovel bucket (bucket)
 83-91 plastering
 83 plasterer
 84 mortar trough
 85 screen
 86-89 ladder scaffold
 86 standard ladder
 87 boards (planks, platform)
 88 diagonal strut (diagonal brace)
 89 railing
 90 guard netting
 91 rope-pulley hoist

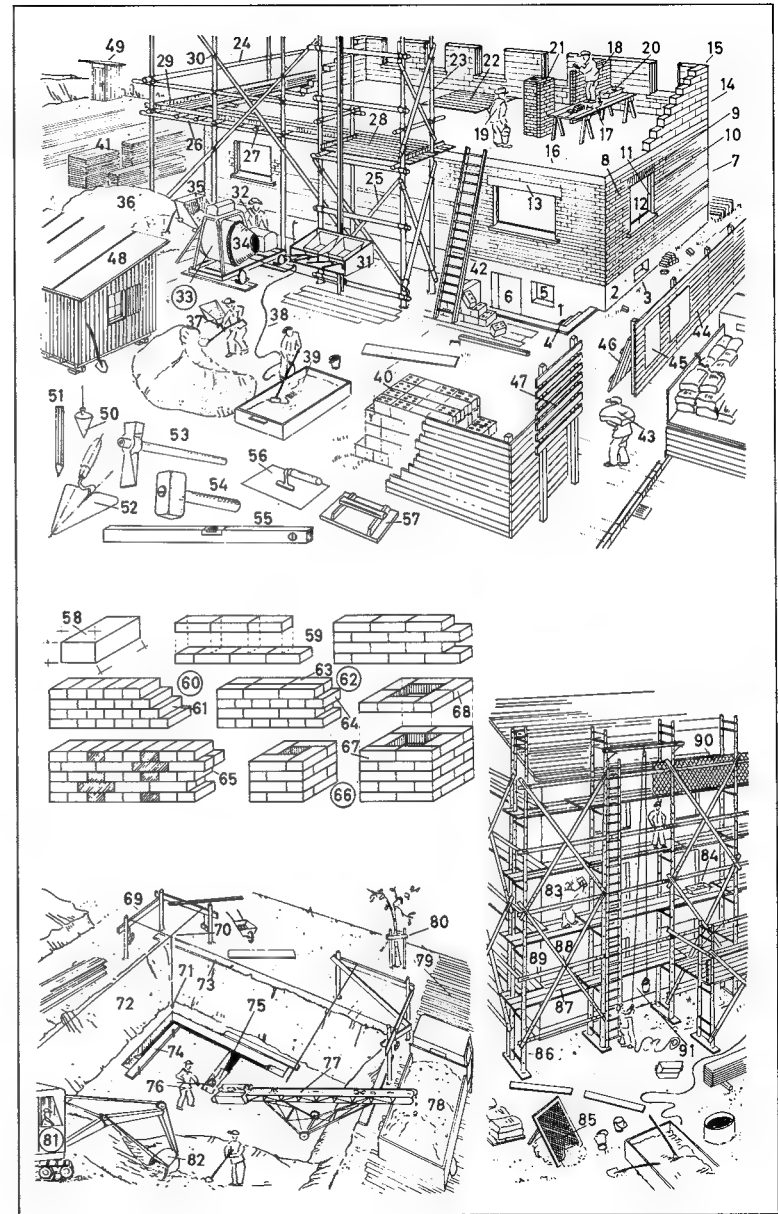

119 Building Site (Construction Site) II

1-89 reinforced concrete (ferroconcrete) construction

- 1 reinforced concrete (ferroconcrete) skeleton construction
- 2 reinforced concrete (ferroconcrete) frame
- 3 inferior purlin
- 4 concrete purlin
- 5 ceiling joist
- 6 arch (flank)
- 7 rubble concrete wall
- 8 reinforced concrete (ferroconcrete) floor
- 9 concreter (concretor), flattening out
- 10 projecting reinforcement (*Am.* connection rebars)
- 11 column box
- 12 joist shuttering
- 13 shuttering strut
- 14 diagonal bracing
- 15 wedge
- 16 board
- 17 sheet pile wall (sheet pile, sheet piling)
- 18 shutter boards (lining boards)
- 19 circular saw (buzz saw)
- 20 bending table
- 21 bar bender (steel bender)
- 22 hand steel shears
- 23 reinforcing steel (reinforcement rods)
- 24 pumice concrete hollow block
- 25 partition wall, a timber wall
- 26 concrete aggregate [gravel and sand of various grades]
- 27 crane track
- 28 tipping wagon (tipping truck)
- 29 concrete mixer
- 30 cement silo
- 31 tower crane (tower slewing crane)
- 32 bogie (*Am.* truck)
- 33 counterweight
- 34 tower
- 35 crane driver's cabin (crane driver's cage)
- 36 jib (boom)
- 37 bearer cable
- 38 concrete bucket
- 39 sleepers (*Am.* ties)
- 40 chock
- 41 ramp
- 42 wheelbarrow
- 43 safety rail
- 44 site hut
- 45 canteen
- 46 tubular steel scaffold (scaffolding)
- 47 standard
- 48 ledger tube
- 49 tie tube
- 50 shoe
- 51 diagonal brace
- 52 planking (platform)
- 53 coupling (coupler)
- 54-76 formwork (shuttering) and reinforcement**
- 54 bottom shuttering (lining)
- 55 side shutter of a purlin
- 56 cut-in bottom
- 57 cross beam
- 58 cramp iron (cramp, dog)
- 59 upright member, a standard
- 60 strap
- 61 cross piece
- 62 stop fillet
- 63 strut (brace, angle brace)
- 64 frame timber (yoke)
- 65 strap
- 66 reinforcement binding
- 67 cross strut (strut)
- 68 reinforcement
- 69 distribution steel
- 70 stirrup
- 71 projecting reinforcement (*Am.* connection rebars)
- 72 concrete (heavy concrete)
- 73 column box
- 74 bolted frame timber (bolted yoke)
- 75 nut (thumb nut)
- 76 shutter board (shuttering board)
- 77-89 tools**
- 77 bending iron
- 78 adjustable service girder
- 79 adjusting screw
- 80 round bar reinforcement
- 81 distance piece (separator, spacer)
- 82 Torsteel
- 83 concrete tamper
- 84 mould (*Am.* mold) for concrete test cubes
- 85 concreter's tongs
- 86 sheeting support
- 87 hand shears
- 88 immersion vibrator (concrete vibrator)
- 89 vibrating cylinder (vibrating head, vibrating poker)

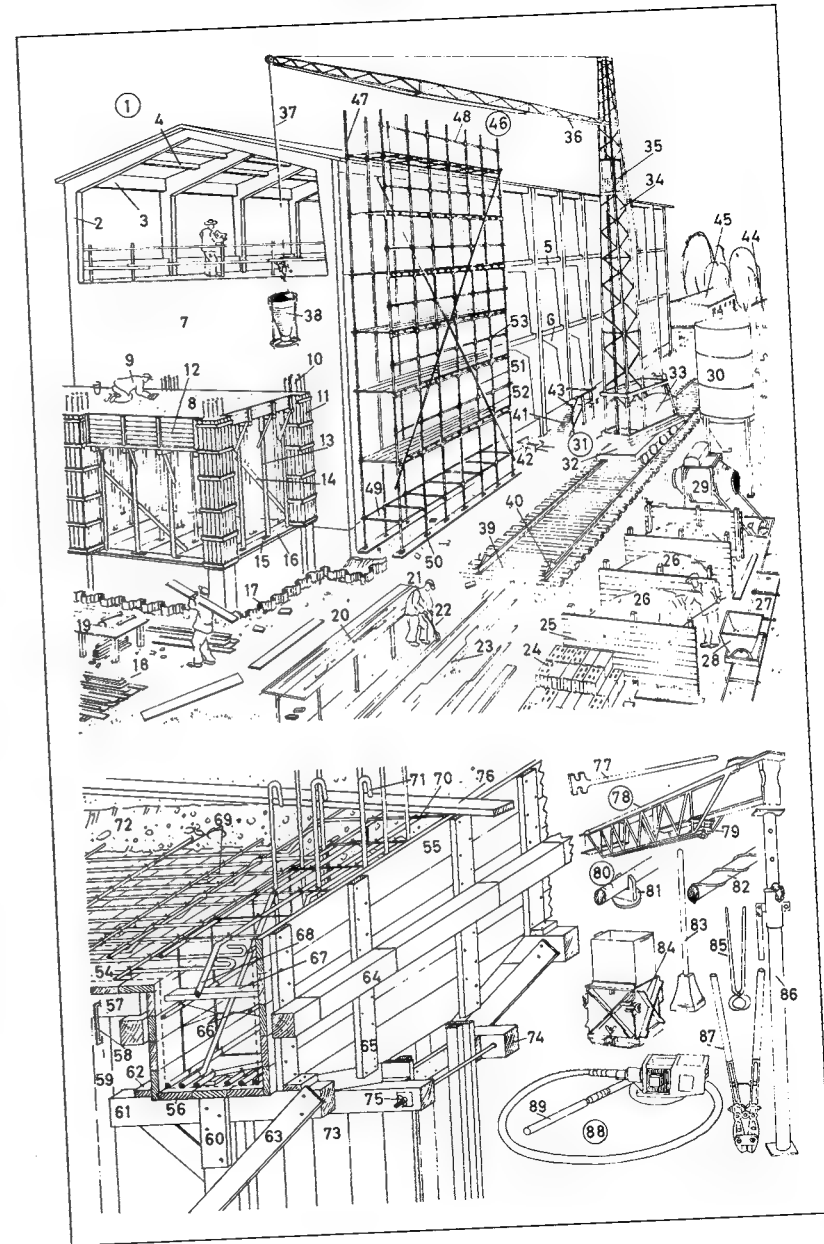

- 1-59 **carpenter's yard**
- 1 stack of boards (planks)
- 2 long timber (*Am.* lumber)
- 3 sawing shed
- 4 carpenter's workshop
- 5 workshop door
- 6 handcart
- 7 roof truss
- 8 tree [used for topping out ceremony], with wreath
- 9 timber wall
- 10 squared timber (building timber, scantlings)
- 11 drawing floor
- 12 carpenter
- 13 safety helmet
- 14 cross-cut saw, a chain saw
- 15 chain guide
- 16 saw chain
- 17 mortiser (chain cutter)
- 18 trestle (horse)
- 19 beam mounted on a trestle
- 20 set of carpenter's tools
- 21 electric drill
- 22 dowel hole
- 23 mark for the dowel hole
- 24 beams
- 25 post (stile, stud, quarter)
- 26 corner brace
- 27 brace (strut)
- 28 base course (plinth)
- 29 house wall (wall)
- 30 window opening
- 31 reveal
- 32 jamb
- 33 window ledge (window sill)
- 34 cornice
- 35 roundwood (round timber)
- 36 floorboards
- 37 hoisting rope
- 38 ceiling joist (ceiling beam, main beam)
- 39 wall joist
- 40 wall plate
- 41 trimmer (trimmer joist, *Am.* header, header joist)
- 42 dragon beam (dragon piece)
- 43 false floor (inserted floor)
- 44 floor filling of breeze, loam, etc.
- 45 fillet (cleat)
- 46 stair well (well)
- 47 chimney
- 48 framed partition (framed wall)

- 49 wall plate
- 50 girt
- 51 window jamb, a jamb
- 52 corner stile (corner strut, corner stud)
- 53 principal post
- 54 brace (strut) with skew notch
- 55 nogging piece
- 56 sill rail
- 57 window lintel (window head)
- 58 head (head rail)
- 59 filled-in panel (bay, pan)
- 60-82 **carpenter's tools**
- 60 hand saw
- 61 bucksaw
- 62 saw blade
- 63 compass saw (keyhole saw)
- 64 plane
- 65 auger (gimlet)
- 66 screw clamp (cramp, holdfast)
- 67 mallet
- 68 two-handed saw
- 69 try square
- 70 broad axe (*Am.* broadax)
- 71 chisel
- 72 mortise axe (mortice axe, *Am.* mortise ax)
- 73 axe (*Am.* ax)
- 74 carpenter's hammer
- 75 claw head (nail claw)
- 76 folding rule
- 77 carpenter's pencil
- 78 iron square
- 79 drawknife (drawshave, drawing knife)
- 80 shaving
- 81 bevel
- 82 mitre square (*Am.* miter square, miter angle)
- 83-96 **building timber**
- 83 undressed timber (*Am.* rough lumber)
- 84 heartwood (duramen)
- 85 sapwood (sap, alburnum)
- 86 bark (rind)
- 87 baulk (balk)
- 88 halved timber
- 89 wane (waney edge)
- 90 quarter baulk (balk)
- 91 plank (board)
- 92 end-grained timber
- 93 heartwood plank (heart plank)
- 94 unsquared (untrimmed) plank (board)
- 95 squared (trimmed) board
- 96 slab (offcut)

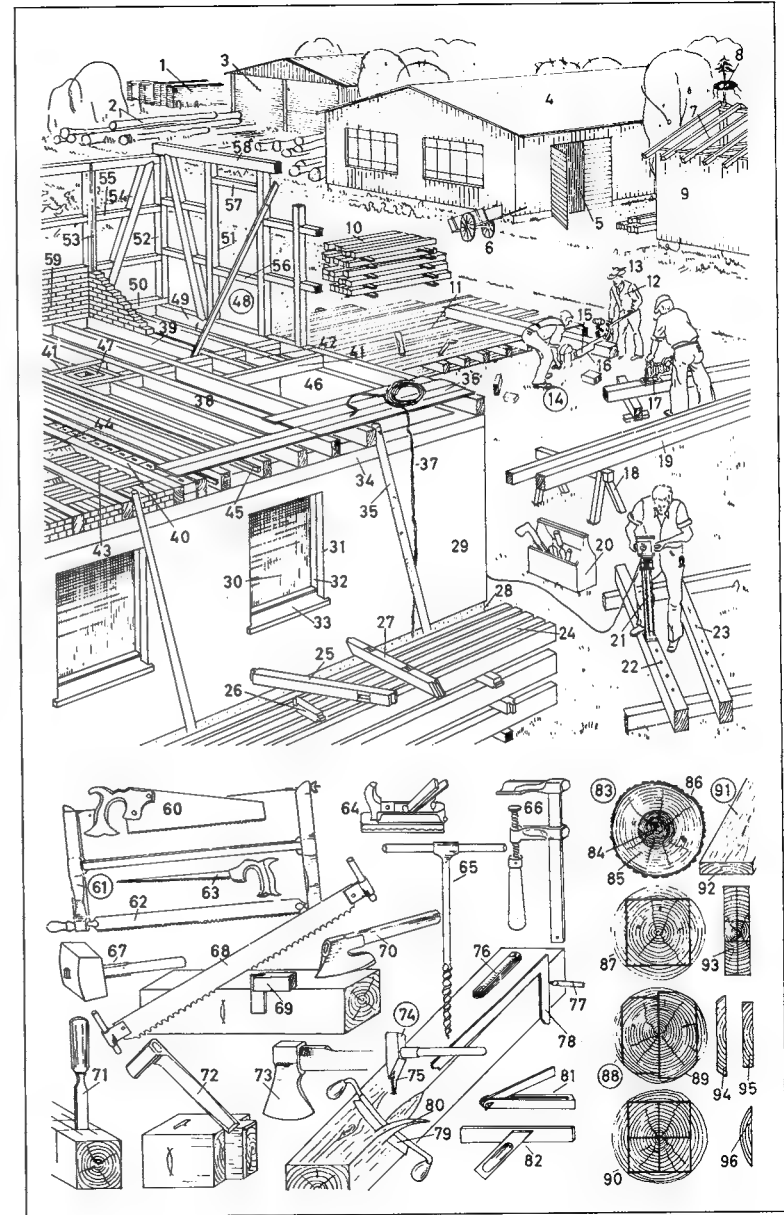

1-26 styles and parts of roofs

- 1 gable roof (saddle roof, saddleback roof)
- 2 ridge
- 3 verge
- 4 eaves
- 5 gable
- 6 dormer window (dormer)
- 7 pent roof (shed roof, lean-to roof)
- 8 skylight
- 9 fire gable
- 10 hip (hipped) roof
- 11 hip end
- 12 hip (arris)
- 13 hip (hipped) dormer window
- 14 ridge turret
- 15 valley (roof valley)
- 16 hipped-gable roof (jerkin head roof)
- 17 partial-hip (partial-hipped) end
- 18 mansard roof (*Am.* gambrel roof)
- 19 mansard dormer window
- 20 sawtooth roof
- 21 north light
- 22 broach roof
- 23 eyebrow
- 24 conical broach roof
- 25 imperial dome (imperial roof)
- 26 weather vane

27-83 roof structures of timber

- 27 rafter roof
- 28 rafter
- 29 roof beam
- 30 diagonal tie (cross tie, sprocket piece, cocking piece)
- 31 arris fillet (tilting fillet)
- 32 outer wall
- 33 beam head
- 34 collar beam roof (trussed rafter roof)
- 35 collar beam (collar)
- 36 rafter
- 37 strutted collar beam roof structure
- 38 collar beams
- 39 purlin
- 40 post (stile, stud)
- 41 brace
- 42 unstrutted (king pin) roof structure
- 43 ridge purlin
- 44 inferior purlin
- 45 rafter head (rafter end)
- 46 purlin roof with queen post and pointing sill
- 47 pointing sill
- 48 ridge beam (ridge board)

49 simple tie

- 50 double tie
- 51 purlin
- 52 purlin roof structure with queen post
- 53 tie beam
- 54 joist (ceiling joist)
- 55 principal rafter
- 56 common rafter
- 57 angle brace (angle tie)
- 58 brace (strut)
- 59 ties
- 60 hip (hipped) roof with purlin roof structure
- 61 jack rafter
- 62 hip rafter
- 63 jack rafter
- 64 valley rafter
- 65 queen truss
- 66 main beam
- 67 summer (summer beam)
- 68 queen post (truss post)
- 69 brace (strut)
- 70 collar beam (collar)
- 71 trimmer (*Am.* header)
- 72 solid-web girder
- 73 lower chord
- 74 upper chord
- 75 boarding
- 76 purlin
- 77 supporting outer wall
- 78 roof truss
- 79 lower chord
- 80 upper chord
- 81 post
- 82 brace (strut)
- 83 support
- 84-98 timber joints**
- 84 mortise (mortice) and tenon joint
- 85 forked mortise (mortice) and tenon joint
- 86 halving (halved) joint
- 87 simple scarf joint
- 88 oblique scarf joint
- 89 dovetail halving
- 90 single skew notch
- 91 double skew notch
- 92 wooden nail
- 93 pin
- 94 clout nail (clout)
- 95 wire nail
- 96 hardwood wedges
- 97 cramp iron (timber dog, dog)
- 98 bolt

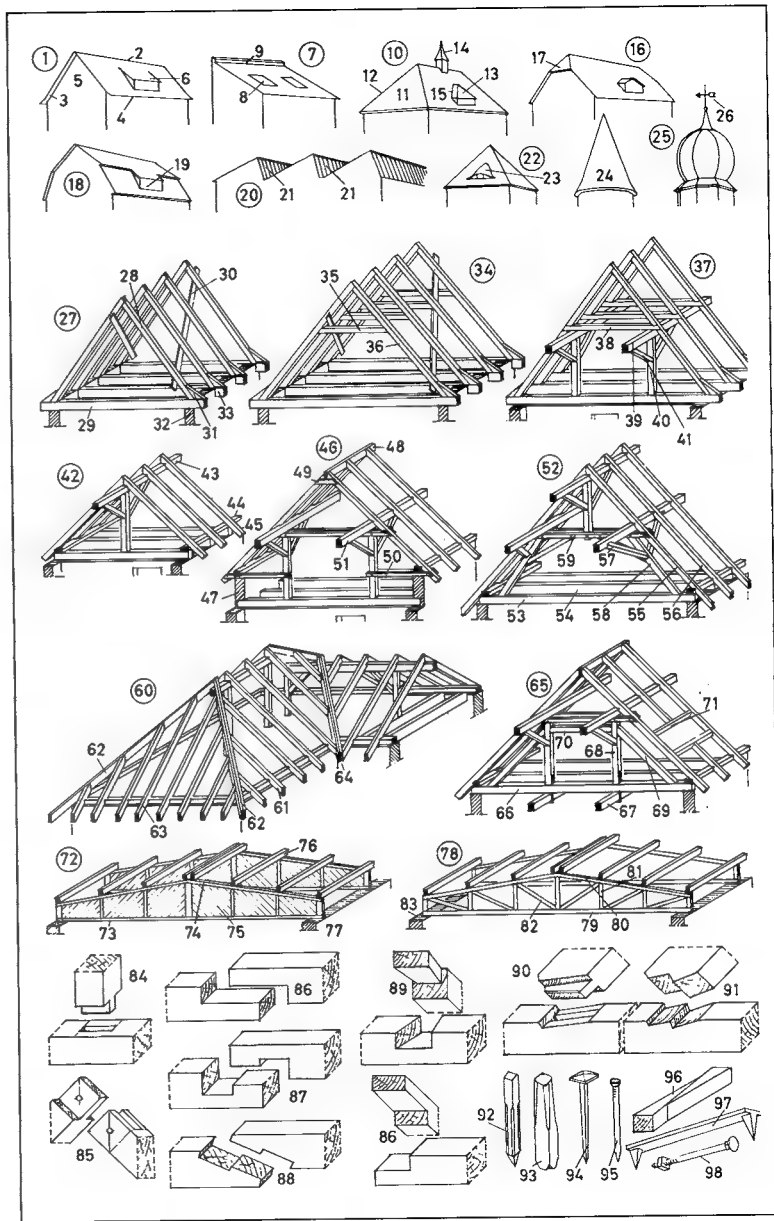

- 1 tiled roof
- 2 plain-tile double-lap roofing
- 3 ridge tile
- 4 ridge course tile
- 5 under-ridge tile
- 6 plain (plane) tile
- 7 ventilating tile
- 8 ridge tile
- 9 hip tile
- 10 hipped end
- 11 valley (roof valley)
- 12 skylight
- 13 chimney
- 14 chimney flashing, made of sheet zinc
- 15 ladder hook
- 16 snow guard bracket
- 17 battens (slating and tiling battens)
- 18 batten gauge (Am. gage)
- 19 rafter
- 20 tile hammer
- 21 lath axe (Am. ax)
- 22 hod
- 23 hod hook
- 24 opening (hatch)
- 25 gable (gable end)
- 26 toothed lath
- 27 soffit
- 28 gutter
- 29 rainwater pipe (downpipe)
- 30 swan's neck (swan-neck)
- 31 pipe clip
- 32 gutter bracket
- 33 tile cutter
- 34 scaffold
- 35 safety wall
- 36 eaves
- 37 outer wall
- 38 exterior rendering
- 39 frost-resistant brickwork
- 40 inferior purlin
- 41 rafter head (rafter end)
- 42 eaves fascia
- 43 double lath (tilting lath)
- 44 insulating boards
- 45-60 tiles and tile roofings**
- 45 split-tiled roof
- 46 plain (plane) tile
- 47 ridge course
- 48 slip
- 49 eaves course
- 50 plain-tiled roof
- 51 nib
- 52 ridge tile
- 53 pantiled roof
- 54 pantile
- 55 pointing

- 56 Spanish-tiled roof (Am. mission-tiled roof)
- 57 under tile
- 58 over tile
- 59 interlocking tile
- 60 flat interlocking tile
- 61-89 slate roof**
- 61 roof boards (roof boarding, roof sheathing)
- 62 roofing paper (sheathing paper); also: roofing felt (Am. rag felt)
- 63 cat ladder (roof ladder)
- 64 coupling hook
- 65 ridge hook
- 66 roof trestle
- 67 trestle rope
- 68 knot
- 69 ladder hook
- 70 scaffold board
- 71 slater
- 72 nail bag
- 73 slate hammer
- 74 slate nail, a galvanized wire nail
- 75 slater's shoe, a bast or hemp shoe
- 76 eaves course (eaves joint)
- 77 corner bottom slate
- 78 roof course
- 79 ridge course (ridge joint)
- 80 gable slate
- 81 tail line
- 82 valley (roof valley)
- 83 box gutter (trough gutter, parallel gutter)
- 84 slater's iron
- 85 slate
- 86 back
- 87 head
- 88 front edge
- 89 tail
- 90-103 asphalt-impregnated paper roofing and corrugated asbestos cement roofing**
- 90 asphalt-impregnated paper roof
- 91 width [parallel to the gutter]
- 92 gutter
- 93 ridge
- 94 join
- 95 width [at right angles to the gutter]
- 96 felt nail (clout nail)
- 97 corrugated asbestos cement roof
- 98 corrugated sheet
- 99 ridge capping piece
- 100 lap
- 101 wood screw
- 102 rust-proof zinc cup
- 103 lead washer

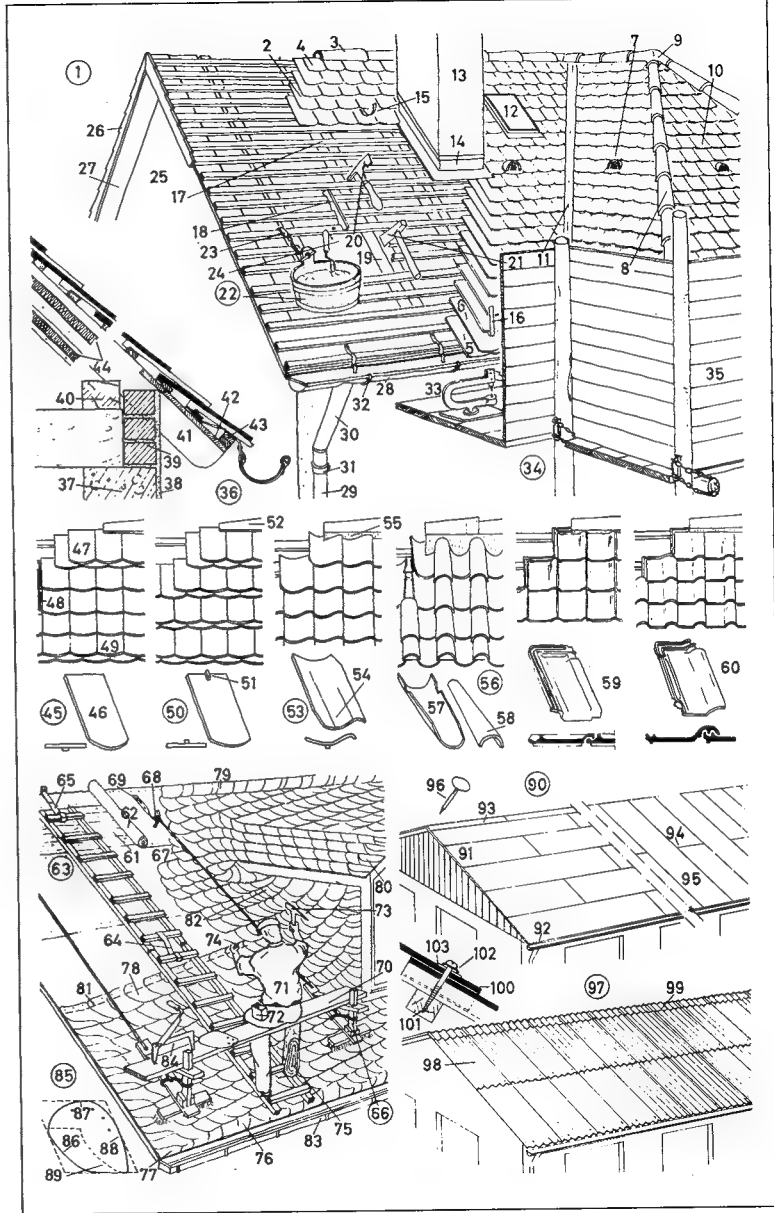

- 1 basement wall, a concrete wall
- 2 footing (foundation)
- 3 foundation base
- 4 damp course (damp-proof course)
- 5 waterproofing
- 6 rendering coat
- 7 brick paving
- 8 sand bed
- 9 ground
- 10 shuttering
- 11 peg
- 12 hardcore
- 13 oversite concrete
- 14 cement screed
- 15 brickwork base
- 16 basement stairs, solid concrete stairs
- 17 block step
- 18 curtail step (bottom step)
- 19 top step
- 20 nosing
- 21 skirting (skirting board, *Am.* mop-board, washboard, scrub board, base)
- 22 balustrade of metal bars
- 23 ground-floor (*Am.* first-floor) landing
- 24 front door
- 25 foot scraper
- 26 flagstone paving
- 27 mortar bed
- 28 concrete ceiling, a reinforced concrete slab
- 29 ground-floor (*Am.* first-floor) brick wall
- 30 ramp
- 31 wedge-shaped step
- 32 tread
- 33 riser
- 34-41 landing
- 34 landing beam
- 35 ribbed reinforced concrete floor
- 36 rib
- 37 steel-bar reinforcement
- 38 subfloor (blind floor)
- 39 level layer
- 40 finishing layer
- 41 top layer (screed)
- 42-44 dog-legged staircase, a staircase without a well

- 42 curtail step (bottom step)
- 43 newel post (newel)
- 44 outer string (*Am.* outer stringer)
- 45 wall string (*Am.* wall stringer)
- 46 staircase bolt
- 47 tread
- 48 riser
- 49 wreath piece (wreathed string)
- 50 balustrade
- 51 baluster
- 52-62 intermediate landing
- 52 wreath
- 53 handrail (guard rail)
- 54 head post
- 55 landing beam
- 56 lining board
- 57 fillet
- 58 lightweight building board
- 59 ceiling plaster
- 60 wall plaster
- 61 false ceiling
- 62 strip flooring (overlay flooring, parquet strip)
- 63 skirting board (*Am.* mopboard, washboard, scrub board, base)
- 64 beading
- 65 staircase window
- 66 main landing beam
- 67 fillet (cleat)
- 68, 69 false ceiling
- 68 false floor (inserted floor)
- 69 floor filling (plugging, pug)
- 70 laths
- 71 lathing
- 72 ceiling plaster
- 73 subfloor (blind floor)
- 74 parquet floor with tongued-and-grooved blocks
- 75 quarter-newelled (*Am.* quarter-neweled) staircase
- 76 winding staircase (spiral staircase) with open newels (open-newel staircase)
- 77 winding staircase (spiral staircase) with solid newels (solid-newel staircase)
- 78 newel (solid newel)
- 79 handrail

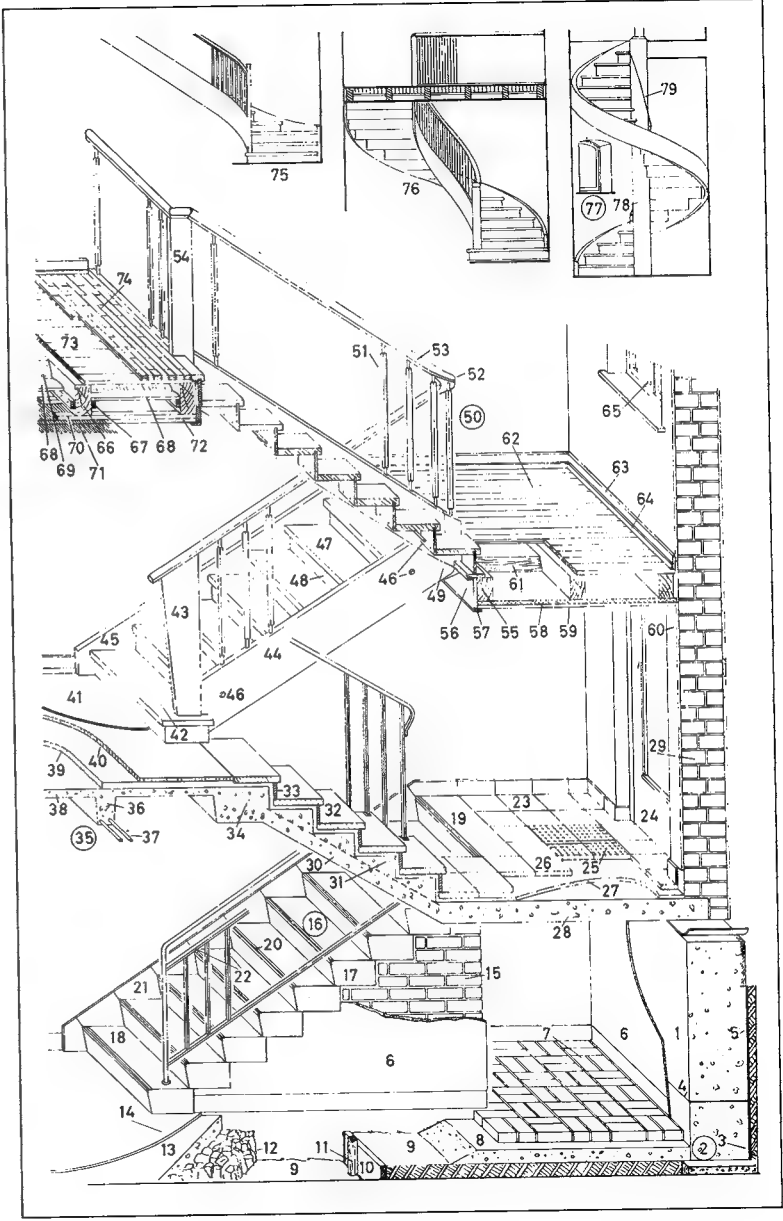

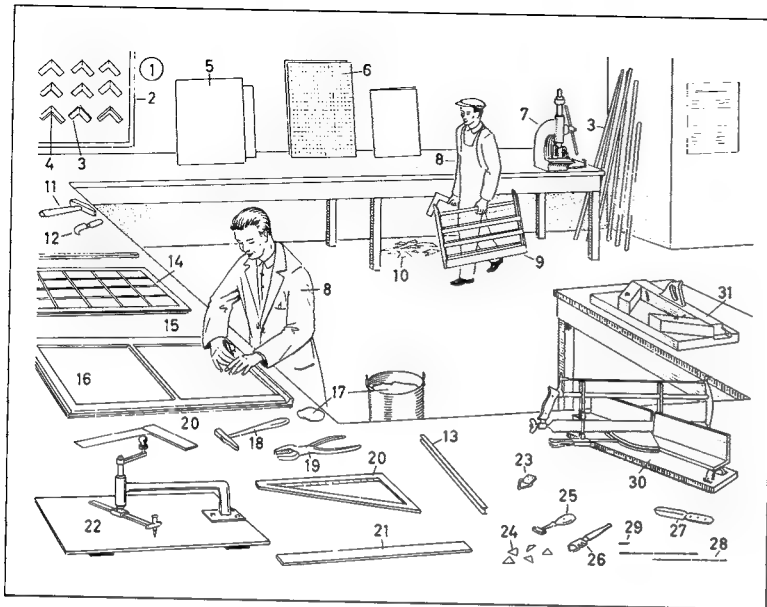

- | | |
|---|---|
| 1 glazier's workshop | 14 leaded light |
| 2 frame wood samples (frame samples) | 15 workbench |
| 3 frame wood | 16 pane of glass |
| 4 mitre joint (mitre, <i>Am.</i> miter joint, miter) | 17 putty |
| 5 sheet glass; <i>kinds:</i> window glass, frosted glass, patterned glass, crystal plate glass, thick glass, milk glass, laminated glass (safety glass, shatterproof glass) | 18 glazier's hammer |
| 6 cast glass; <i>kinds:</i> stained glass, ornamental glass, raw glass, bull's-eye glass, wired glass, line glass (lined glass) | 19 glass pliers |
| 7 mitring (<i>Am.</i> mitering) machine | 20 glazier's square |
| 8 glassworker (e.g. building glazier, glazier, decorative glass worker) | 21 glazier's rule |
| 9 glass holder | 22 glazier's beam compass |
| 10 piece of broken glass | 23 eyelet |
| 11 lead hammer | 24 glazing sprig |
| 12 lead knife | 25, 26 glass cutters |
| 13 came (lead came) | 25 diamond glass cutter |
| | 26 steel-wheel (steel) glass cutter |
| | 27 putty knife |
| | 28 pin wire |
| | 29 panel pin |
| | 30 mitre (<i>Am.</i> miter) block (mitre box) [with saw] |
| | 31 mitre (<i>Am.</i> miter) shoot (mitre board) |

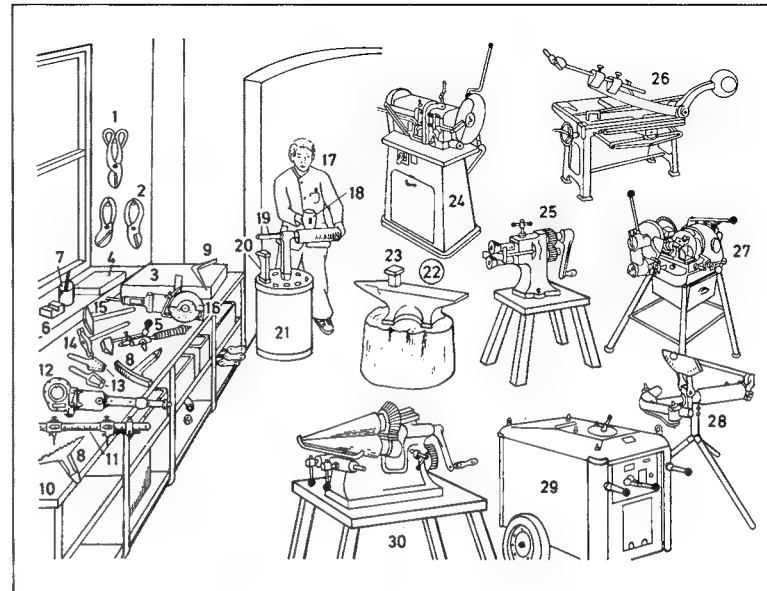

- | | |
|---|---|
| 1 metal shears (tinner's snips, <i>Am.</i> tinner's shears) | 18 mallet |
| 2 elbow snips (angle shears) | 19 mandrel |
| 3 gib | 20 socket (tinner's socket) |
| 4 lapping plate | 21 block |
| 5-7 propane soldering apparatus | 22 anvil |
| 5 propane soldering iron, a hatchet iron | 23 stake |
| 6 soldering stone, a sal-ammoniac block | 24 circular saw (buzz saw) |
| 7 soldering fluid (flux) | 25 flanging, swaging, and wiring machine |
| 8 beading iron for forming reinforcement beading | 26 sheet shears (guillotine) |
| 9 angled reamer | 27 screw-cutting machine (thread-cutting machine, die stocks) |
| 10 workbench (bench) | 28 pipe-bending machine (bending machine, pipe bender) |
| 11 beam compass (trammel, <i>Am.</i> beam trammel) | 29 welding transformer |
| 12 electric hand die | 30 bending machine (rounding machine) for shaping funnels |
| 13 hollow punch | |
| 14 chamfering hammer | |
| 15 beading swage (beading hammer) | |
| 16 abrasive-wheel cutting-off machine | |
| 17 plumber | |

- 1 gas fitter and plumber
- 2 stepladder
- 3 safety chain
- 4 stop valve
- 5 gas meter
- 6 bracket
- 7 service riser
- 8 distributing pipe
- 9 supply pipe
- 10 pipe-cutting machine
- 11 pipe repair stand
- 12-25 gas and water appliances**
- 12, 13** geyser, an instantaneous water heater
- 12 gas water heater
- 13 electric water heater
- 14 toilet cistern
- 15 float
- 16 bell
- 17 flush pipe
- 18 water inlet
- 19 flushing lever (lever)
- 20 radiator
- 21 radiator rib
- 22 two-pipe system
- 23 flow pipe
- 24 return pipe
- 25 gas heater
- 26-37 plumbing fixtures**
- 26 trap (anti-syphon trap)
- 27 mixer tap (*Am.* mixing faucet) for washbasins
- 28 hot tap
- 29 cold tap
- 30 extendible shower attachment
- 31 water tap (pillar tap) for washbasins
- 32 spindle top
- 33 shield
- 34 draw-off tap (*Am.* faucet)
- 35 supatap
- 36 swivel tap
- 37 flushing valve
- 38-52 fittings**
- 38 joint with male thread
- 39 reducing socket (reducing coupler)
- 40 elbow screw joint (elbow coupling)
- 41 reducing socket (reducing coupler) with female thread
- 42 screw joint
- 43 coupler (socket)
- 44 T-joint (T-junction joint, tee)
- 45 elbow screw joint with female thread
- 46 bend
- 47 T-joint (T-junction joint, tee) with female taper thread
- 48 ceiling joint
- 49 reducing elbow
- 50 cross
- 51 elbow joint with male thread
- 52 elbow joint
- 53-57 pipe supports**
- 53 saddle clip
- 54 spacing bracket
- 55 plug
- 56 pipe clips
- 57 two-piece spacing clip
- 58-86 plumber's tools, gas fitter's tools**
- 58 gas pliers
- 59 footprints
- 60 combination cutting pliers
- 61 water pump pliers
- 62 flat-nose pliers
- 63 nipple key
- 64 round-nose pliers
- 65 pincers
- 66 adjustable S-wrench
- 67 screw wrench
- 68 shifting spanner
- 69 screwdriver
- 70 compass saw (keyhole saw)
- 71 hacksaw frame
- 72 hand saw
- 73 soldering iron
- 74 blowlamp (blowtorch) [for soldering]
- 75 sealing tape
- 76 tin-lead solder
- 77 club hammer
- 78 hammer
- 79 spirit level
- 80 steel-leg vice (*Am.* vise)
- 81 pipe vice (*Am.* vise)
- 82 pipe-bending machine
- 83 former (template)
- 84 pipe cutter
- 85 hand die
- 86 screw-cutting machine (thread-cutting machine)

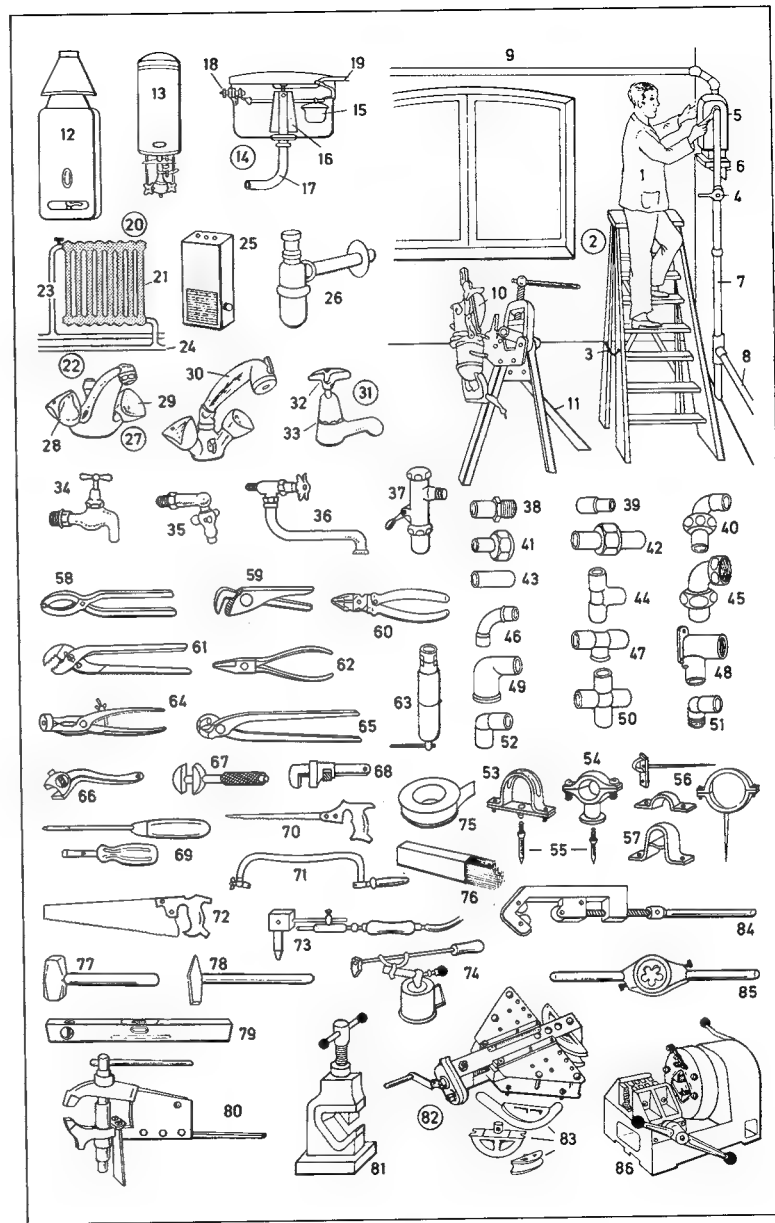

127 Electrician

- 1 electrician (electrical fitter, wireman)
- 2 bell push (doorbell) for low-voltage safety current
- 3 house telephone with call button
- 4 [flush-mounted] rocker switch
- 5 [flush-mounted] earthed socket (wall socket, plug point, *Am.* wall outlet, convenience outlet, outlet)
- 6 [surface-mounted] earthed double socket (double wall socket, double plug point, *Am.* double wall outlet, double convenience outlet, double outlet)
- 7 switched socket (switch and socket)
- 8 four-socket (four-way) adapter
- 9 earthed plug
- 10 extension lead (*Am.* extension cord)
- 11 extension plug
- 12 extension socket
- 13 surface-mounted three-pole earthed socket [for three-phase circuit] with neutral conductor
- 14 three-phase plug
- 15 electric bell (electric buzzer)
- 16 pull-switch (cord-operated wall switch)
- 17 dimmer switch [for smooth adjustment of lamp brightness]
- 18 drill-cast rotary switch
- 19 miniature circuit breaker (screw-in circuit breaker, fuse)
- 20 resetting button
- 21 set screw [for fuses and miniature circuit breakers]
- 22 underfloor mounting (underfloor sockets)
- 23 hinged floor socket for power lines and communication lines
- 24 sunken floor socket with hinged lid (snap lid)
- 25 surface-mounted socket outlet (plug point) box
- 26 pocket torch, a torch (*Am.* flashlight)
- 27 dry cell battery
- 28 contact spring

- 29 strip of thermoplastic connectors
- 30 steel draw-in wire (draw wire) with threading key, and ring attached
- 31 electricity meter cupboard
- 32 electricity meter
- 33 miniature circuit breakers (miniature circuit breaker consumer unit)
- 34 insulating tape (*Am.* friction tape)
- 35 fuse holder
- 36 circuit breaker (fuse), a fuse cartridge with fusible element
- 37 colour (*Am.* color) indicator [showing current rating]
- 38, 39 contact maker
- 40 cable clip
- 41 universal test meter (multiple meter for measuring current and voltage)
- 42 thermoplastic moisture-proof cable
- 43 copper conductor
- 44 three-core cable
- 45 electric soldering iron
- 46 screwdriver
- 47 water pump pliers
- 48 shock-resisting safety helmet
- 49 tool case
- 50 round-nose pliers
- 51 cutting pliers
- 52 junior hacksaw
- 53 combination cutting pliers
- 54 insulated handle
- 55 continuity tester
- 56 electric light bulb (general service lamp, filament lamp)
- 57 glass bulb (bulb)
- 58 coiled-coil filament
- 59 screw base
- 60 lampholder
- 61 fluorescent tube
- 62 bracket for fluorescent tubes
- 63 electrician's knife
- 64 wire strippers
- 65 bayonet fitting
- 66 three-pin socket with switch
- 67 three-pin plug
- 68 fuse carrier with fuse wire
- 69 light bulb with bayonet fitting

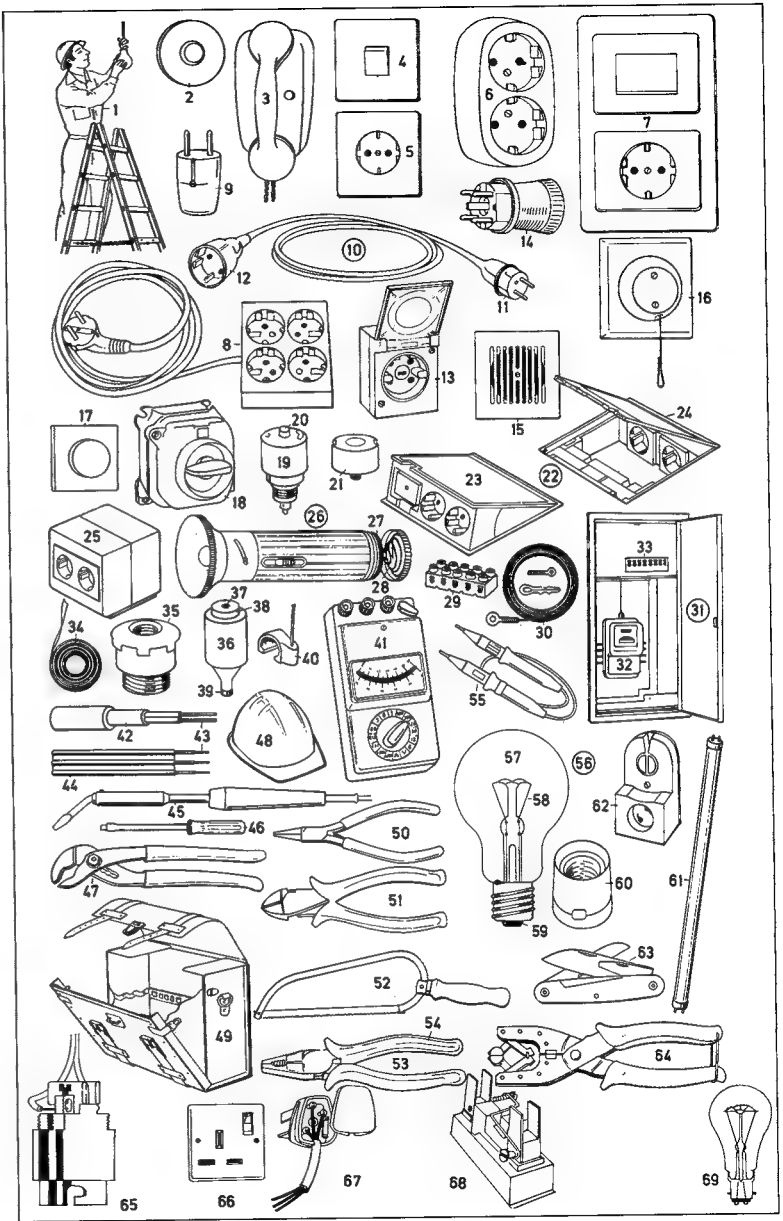

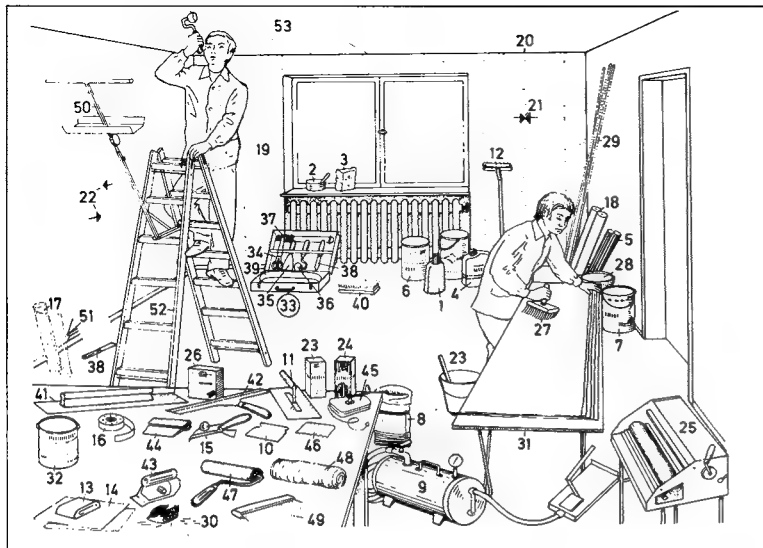
**1-17 preparation of surfaces**

- 1 wallpaper-stripping liquid (stripper)
- 2 plaster (plaster of Paris)
- 3 filler
- 4 glue size (size)
- 5 lining paper, a backing paper
- 6 primer
- 7 fluate
- 8 shredded lining paper
- 9 wallpaper-stripping machine (stripper)
- 10 scraper
- 11 smoother
- 12 perforator
- 13 sandpaper block
- 14 sandpaper
- 15 stripping knife
- 16 masking tape
- 17 strip of sheet metal [on which wallpaper is laid for cutting]
- 18-53 wallpapering (paper hanging)**
- 18 wallpaper (*kinds*: wood pulp paper, wood chip paper, fabric wallhangings, synthetic wallpaper, metallic paper, natural (e.g. wood or cork) paper, tapestry wallpaper)
- 19 length of wallpaper
- 20 butted paper edges
- 21 matching edge
- 22 non-matching edge
- 23 wallpaper paste

- 24 heavy-duty paste
- 25 pasting machine
- 26 paste [for the pasting machine]
- 27 paste brush
- 28 emulsion paste
- 29 picture rail
- 30 beading pins
- 31 pasteboard (paperhanger's bench)
- 32 gloss finish
- 33 paperhanging kit
- 34 shears (bull-nosed scissors)
- 35 filling knife
- 36 seam roller
- 37 hacking knife
- 38 knife (trimming knife)
- 39 straightedge
- 40 paperhanging brush
- 41 wallpaper-cutting board
- 42 cutter
- 43 trimmer
- 44 plastic spatula
- 45 chalked string
- 46 spreader
- 47 paper roller
- 48 flannel cloth
- 49 dry brush
- 50 ceiling paperhanger
- 51 overlap angle
- 52 paperhanger's trestles
- 53 ceiling paper

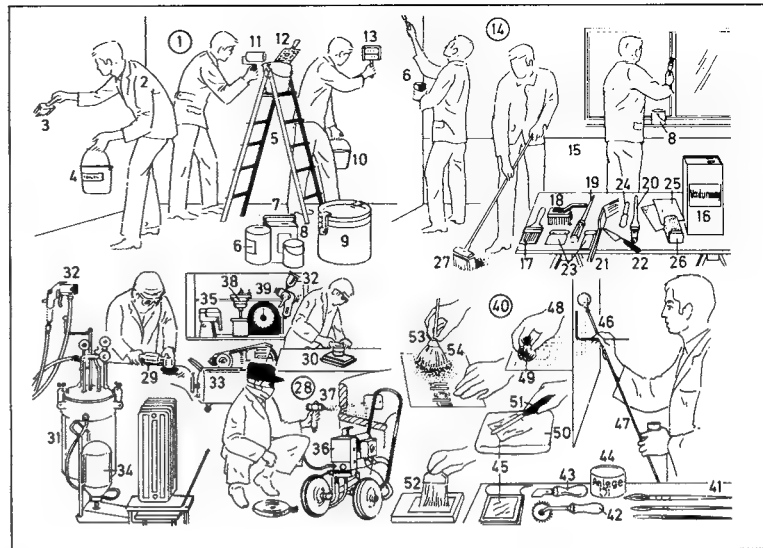
**1 painting**

- 1 painter
- 3 paintbrush
- 4 emulsion paint (emulsion)
- 5 stepladder
- 6 can (tin) of paint
- 7, 8 cans (tins) of paint
- 7 can (tin) with fixed handle
- 8 paint kettle
- 9 drum of paint
- 10 paint bucket
- 11 paint roller
- 12 grill [for removing excess paint from the roller]
- 13 stippling roller
- 14 varnishing
- 15 oil-painted dado
- 16 canister for thinner
- 17 flat brush for larger surfaces (flat wall brush)
- 18 stippler
- 19 fitch
- 20 cutting-in brush
- 21 radiator brush (flay brush)
- 22 paint scraper
- 23 scraper
- 24 putty knife
- 25 sandpaper
- 26 sandpaper block
- 27 floor brush

28 sanding and spraying

- 29 grinder
- 30 sander
- 31 pressure pot
- 32 spray gun
- 33 compressor (air compressor)
- 34 flow coating machine for flow coating radiators, etc.
- 35 hand spray
- 36 airless spray unit
- 37 airless spray gun
- 38 efflux viscometer
- 39 seconds timer
- 40 lettering and gilding**
- 41 lettering brush (signwriting brush, pencil)
- 42 tracing wheel
- 43 stencil knife
- 44 oil gold size
- 45 gold leaf
- 46 outline drawing
- 47 mahlstick
- 48 pouncing
- 49 pounce bag
- 50 gilder's cushion
- 51 gilder's knife
- 52 sizing gold leaf
- 53 filling in the letters with stipple paint
- 54 gilder's mop

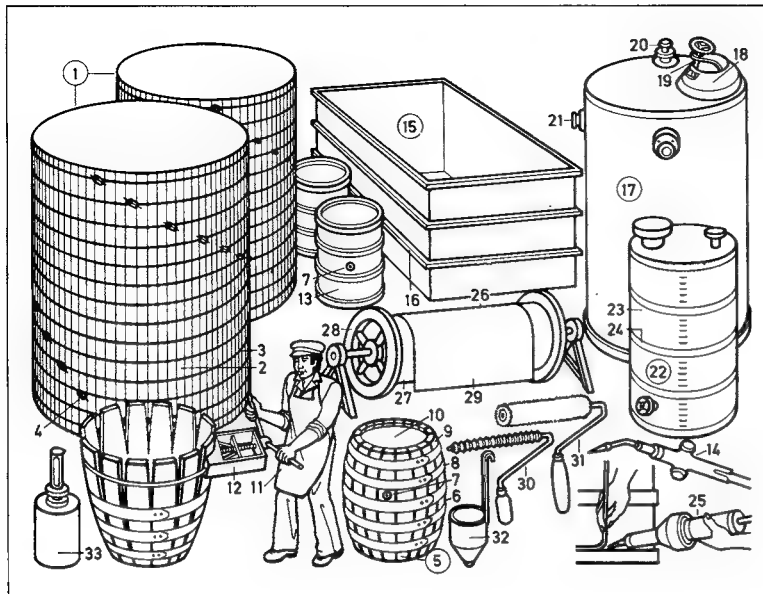

1-33 cooper's and tank construction engineer's workshops

- | | |
|--|--|
| 1 tank | 18 manhole |
| 2 circumference made of staves (staved circumference) | 19 manhole cover with handwheel |
| 3 iron rod | 20 flange mount |
| 4 turnbuckle | 21 flange-type stopcock |
| 5 barrel (cask) | 22 measuring tank |
| 6 body of barrel (of cask) | 23 shell (circumference) |
| 7 bunghole | 24 shrink ring |
| 8 band (hoop) of barrel | 25 hot-air gun |
| 9 barrel stave | 26 roller made of glass fibre (Am. glass fiber) reinforced synthetic resin |
| 10 barrelhead (heading) | 27 cylinder |
| 11 cooper | 28 flange |
| 12 trusser | 29 glass cloth |
| 13 drum | 30 grooved roller |
| 14 gas welding torch | 31 lambskin roller |
| 15 staining vat, made of thermoplastics | 32 ladle for testing viscosity |
| 16 iron reinforcing bands | 33 measuring vessel for hardener |
| 17 storage container, made of glass fibre (Am. glass fiber) reinforced polyester resin | |



1-25 furrier's workroom

- | | |
|--|-----------------------------------|
| 1 furrier | 20 lynx fur, sewn together (sewn) |
| 2 steam spray gun | 21 broadtail |
| 3 steam iron | 22 fur marker |
| 4 beating machine | 23 fur worker |
| 5 cutting machine for letting out furskins | 24 mink coat |
| 6 uncut furskin | 25 ocelot coat |
| 7 let-out strips (let-out sections) | |
| 8 fur worker | |
| 9 fur-sewing machine | |
| 10 blower for letting out | |
| 11-21 furskins | |
| 11 mink skin | |
| 12 fur side | |
| 13 leather side | |
| 14 cut furskin | |
| 15 lynx skin before letting out | |
| 16 let-out lynx skin | |
| 17 fur side | |
| 18 leather side | |
| 19 let-out mink skin | |

1-73 joiner's workshop

1-28 joiner's tools

- 1 wood rasp
- 2 wood file
- 3 compass saw (keyhole saw)
- 4 saw handle
- 5 [square-headed] mallet
- 6 try square
- 7-11 chisels
- 7 bevelled-edge chisel (chisel)
- 8 mortise (mortice) chisel
- 9 gouge
- 10 handle
- 11 framing chisel (cant chisel)
- 12 glue pot in water bath
- 13 glue pot (glue well), an insert for joiner's glue
- 14 handscrew
- 15-28 planes
- 15 smoothing plane
- 16 jack plane
- 17 toothing plane
- 18 handle (toat)
- 19 wedge
- 20 plane iron (cutter)
- 21 mouth
- 22 sole
- 23 side
- 24 stock (body)
- 25 rebate (rabbet) plane
- 26 router plane (old woman's tooth)
- 27 spokeshave
- 28 compass plane
- 29-37 woodworker's bench
- 29 foot
- 30 front vice (*Am. vise*)
- 31 vice (*Am. vise*) handle
- 32 vice (*Am. vise*) screw
- 33 jaw
- 34 bench top
- 35 well
- 36 bench stop (bench holdfast)
- 37 tail vice (*Am. vise*)
- 38 cabinet maker (joiner)
- 39 trying plane
- 40 shavings
- 41 wood screw

- 42 saw set
- 43 mitre (*Am. miter*) box
- 44 tenon saw
- 45 thicknesser (thicknessing machine)
- 46 thicknessing table with rollers
- 47 kick-back guard
- 48 chip-extractor opening
- 49 chain mortising machine (chain mortiser)
- 50 endless mortising chain
- 51 clamp (work clamp)
- 52 knot hole moulding (*Am. molding*) machine
- 53 knot hole cutter
- 54 quick-action chuck
- 55 hand lever
- 56 change-gear handle
- 57 sizing and edging machine
- 58 main switch
- 59 circular-saw (buzz saw) blade
- 60 height (rise and fall) adjustment wheel
- 61 V-way
- 62 framing table
- 63 extension arm (arm)
- 64 trimming table
- 65 fence
- 66 fence adjustment handle
- 67 clamp lever
- 68 board-sawing machine
- 69 swivel motor
- 70 board support
- 71 saw carriage
- 72 pedal for raising the transport rollers
- 73 blockboard

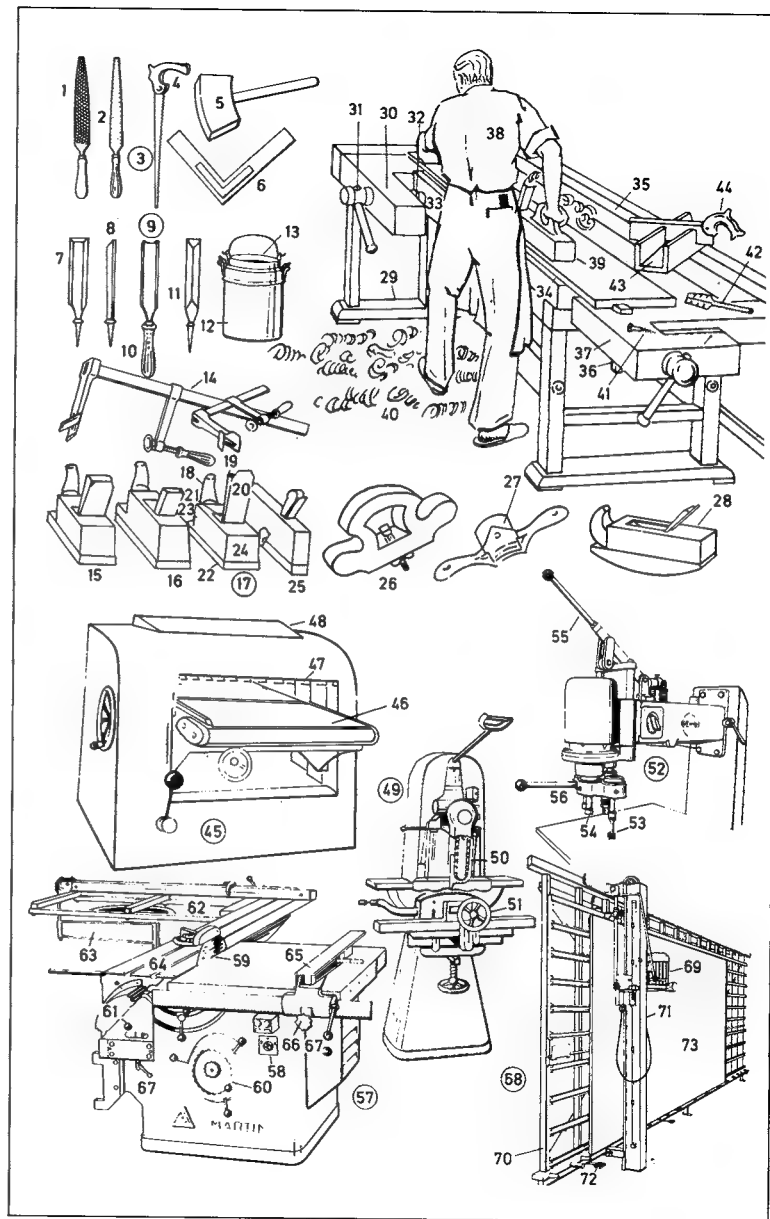

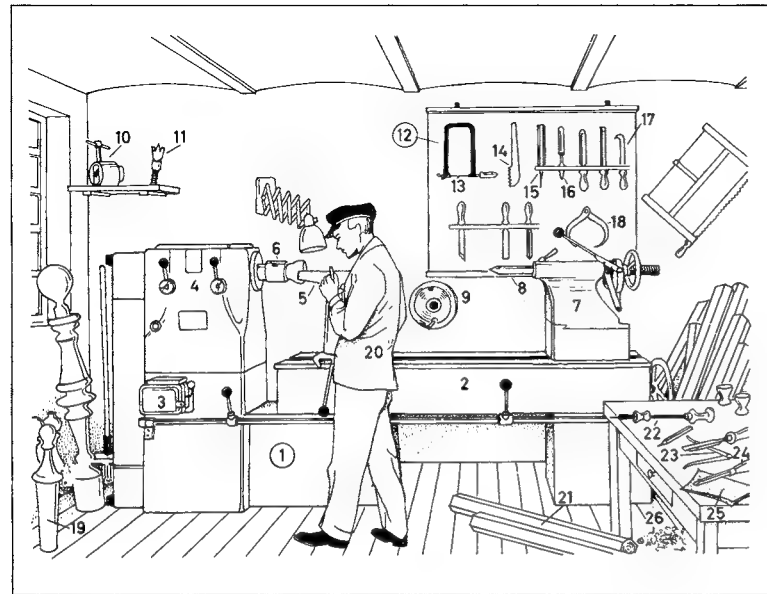
**1-26 turnery (turner's workshop)**

- 1 wood-turning lathe (lathe)
- 2 lathe bed
- 3 starting resistance (starting resistor)
- 4 gearbox
- 5 tool rest
- 6 chuck
- 7 tailstock
- 8 centre (*Am.* center)
- 9 driving plate with pin
- 10 two-jaw chuck
- 11 live centre (*Am.* center)
- 12 fretsaw
- 13 fretsaw blade
- 14, 15, 24 turning tools
- 14 thread chaser, for cutting threads in wood
- 15 gouge, for rough turning
- 16 spoon bit (shell bit)
- 17 hollowing tool
- 18 outside calliper (caliper)
- 19 turned work (turned wood)

20 master turner (turner)

- 21 [piece of] rough wood
- 22 drill
- 23 inside calliper (caliper)
- 24 parting tool
- 25 glass paper (sandpaper, emery paper)
- 26 shavings

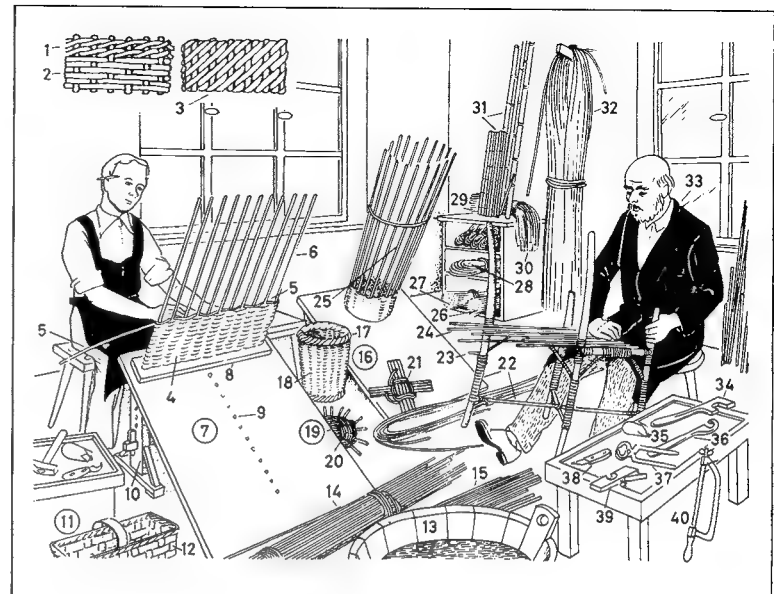
**1-40 basket making (basketry, basketwork)****1-4 weaves (strokes)**

- 1 randing
- 2 rib randing
- 3 oblique randing
- 4 randing, a piece of wickerwork (screen work)
- 5 weaver
- 6 stake
- 7 workboard: *also*: lapboard
- 8 screw block
- 9 hole for holding the block
- 10 stand
- 11 chip basket (spale basket)
- 12 chip (spale)
- 13 soaking tub
- 14 willow stakes (osier stakes)
- 15 willow rods (osier rods)
- 16 basket, a piece of wickerwork (basketwork)
- 17 border
- 18 woven side
- 19 round base

20 woven base**21 slath****22-24 covering a frame**

- 22 frame
- 23 end
- 24 rib
- 25 upsett
- 26 grass; *kinds*: esparto grass, alfalfa grass
- 27 rush (bulrush, reed mace)
- 28 reed
- 29 raffia (bast)
- 30 straw
- 31 bamboo cane
- 32 rattan (ratan) chair cane
- 33 basket maker
- 34 bending tool
- 35 cutting point (bodkin)
- 36 rapping iron
- 37 pincers
- 38 picking knife
- 39 shave
- 40 hacksaw

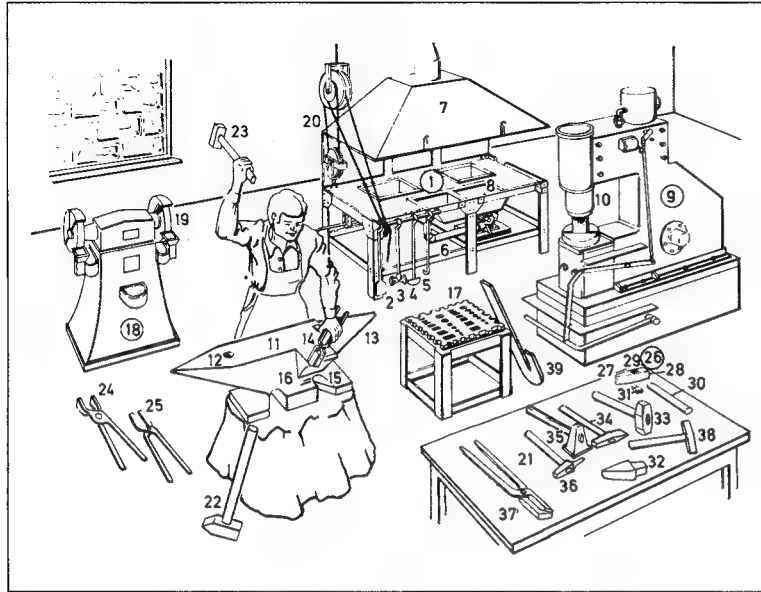
**1-8 hearth (forge) with blacksmith's fire**

- 1 hearth (forge)
- 2 shovel (slice)
- 3 swab
- 4 rake
- 5 poker
- 6 blast pipe (tue iron)
- 7 chimney (cowl, hood)
- 8 water trough (quenching trough, bosh)
- 9 power hammer
- 10 ram (tup)
- 11-16 anvil**
- 11 anvil
- 12 flat beak (beck, bick)
- 13 round beak (beck, bick)
- 14 auxiliary table
- 15 foot
- 16 upsetting block
- 17 swage block
- 18 tool-grinding machine (tool grinder)

- 19 grinding wheel
- 20 block and tackle
- 21 workbench (bench)
- 22-39 blacksmith's tools**
- 22 sledge hammer
- 23 blacksmith's hand hammer
- 24 flat tongs
- 25 round tongs
- 26 parts of the hammer
- 27 peen (pane, pein)
- 28 face
- 29 eye
- 30 haft
- 31 cotter punch
- 32 hardy (hardie)
- 33 set hammer
- 34 sett (set, sate)
- 35 flat-face hammer (flatter)
- 36 round punch
- 37 angle tongs
- 38 blacksmith's chisel (scaling hammer, chipping hammer)
- 39 moving iron (bending iron)

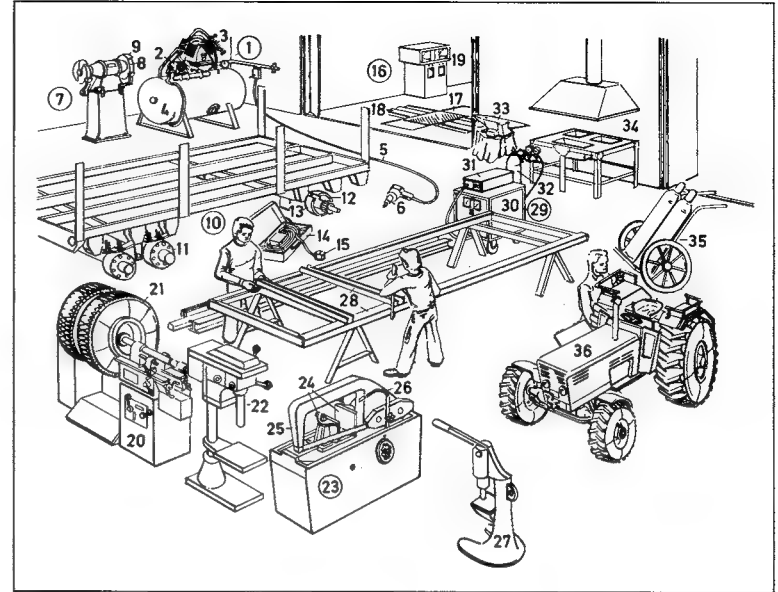

- 1 compressed-air system
- 2 electric motor
- 3 compressor
- 4 compressed-air tank
- 5 compressed-air line
- 6 percussion screwdriver
- 7 pedestal grinding machine (floor grinding machine)
- 8 grinding wheel
- 9 guard
- 10 trailer
- 11 brake drum
- 12 brake shoe
- 13 brake lining
- 14 testing kit
- 15 pressure gauge (*Am. gage*)
- 16 brake-testing equipment, a rolling road
- 17 pit
- 18 braking roller
- 19 meter (recording meter)
- 20 precision lathe for brake drums
- 21 lorry wheel
- 22 boring mill
- 23 power saw, a hacksaw (power hacksaw)
- 24 vice (*Am. vise*)
- 25 saw frame
- 26 coolant supply pipe
- 27 riveting machine
- 28 trailer frame (chassis) under construction
- 29 inert-gas welding equipment
- 30 rectifier
- 31 control unit
- 32 CO₂ cylinder
- 33 anvil
- 34 hearth (forge) with blacksmith's fire
- 35 trolley for gas cylinders
- 36 vehicle under repair, a tractor

139 Hammer Forging (Smith Forging) and Drop Forging

- 1 continuous furnace with grid hearth for annealing of round stock
- 2 discharge opening (discharge door)
- 3 gas burners
- 4 charging door
- 5 counterblow hammer
- 6 upper ram
- 7 lower ram
- 8 ram guide
- 9 hydraulic drive
- 10 column
- 11 short-stroke drop hammer
- 12 ram (tup)
- 13 upper die block
- 14 lower die block
- 15 hydraulic drive
- 16 frame
- 17 anvil
- 18 forging and sizing press
- 19 standard
- 20 table
- 21 disc (disk) clutch
- 22 compressed-air pipe
- 23 solenoid valve
- 24 air-lift gravity hammer (air-lift drop hammer)
- 25 drive motor
- 26 hammer (tup)
- 27 foot control (foot pedal)
- 28 preshaped (blocked) workpiece
- 29 hammer guide
- 30 hammer cylinder
- 31 anvil
- 32 mechanical manipulator to move the workpiece in hammer forging
- 33 dogs
- 34 counterweight
- 35 hydraulic forging press
- 36 crown
- 37 cross head
- 38 upper die block
- 39 lower die block
- 40 anvil
- 41 hydraulic piston
- 42 pillar guide
- 43 rollover device
- 44 burden chain (chain sling)
- 45 crane hook
- 46 workpiece
- 47 gas furnace (gas-fired furnace)
- 48 gas burner
- 49 charging opening
- 50 chain curtain
- 51 vertical-lift door
- 52 hot-air duct
- 53 air preheater
- 54 gas pipe
- 55 electric door-lifting mechanism
- 56 air blast

Hammer Forging (Smith Forging) and Drop Forging 139

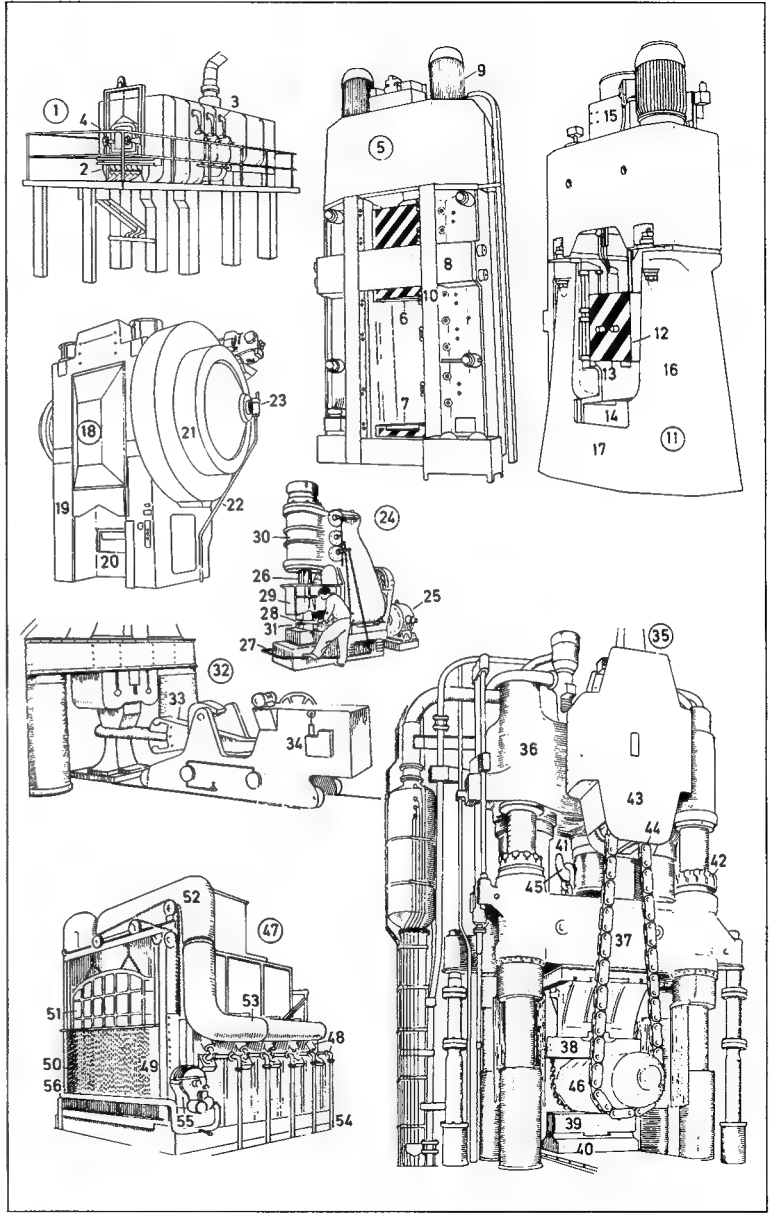

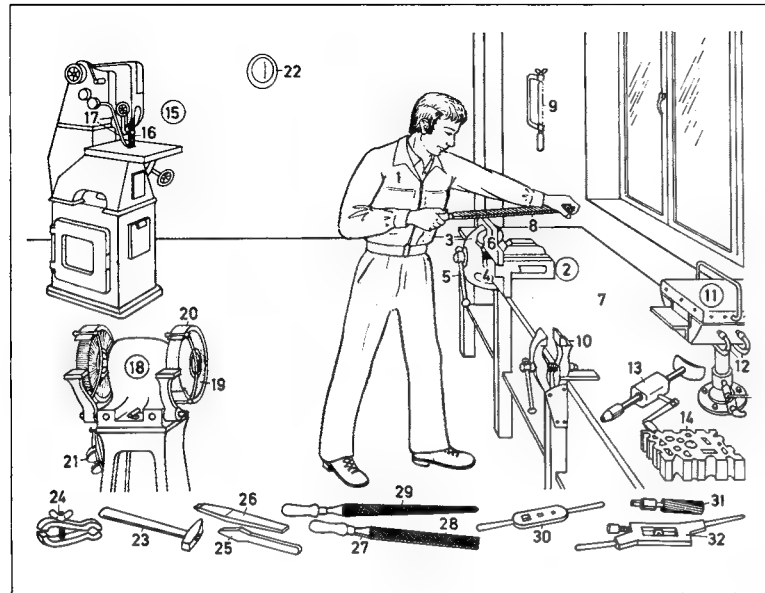

1-22 metalwork shop (mechanic's workshop, fitter's workshop, locksmith's workshop)

- 1 metalworker (*e.g.* mechanic, fitter, locksmith; *form. also:* wrought-iron craftsman)
- 2 parallel-jaw vice (*Am. vise*)
- 3 jaw
- 4 screw
- 5 handle
- 6 workpiece
- 7 workbench (bench)
- 8 files (*kinds:* rough file, smooth file, precision file)
- 9 hacksaw
- 10 leg vice (*Am. vise*), a spring vice
- 11 muffle furnace, a gas-fired furnace
- 12 gas pipe
- 13 hand brace (hand drill)
- 14 swage block
- 15 filing machine
- 16 file
- 17 compressed-air pipe

- 18 grinding machine (grinder)
- 19 grinding wheel
- 20 guard
- 21 goggles (safety glasses)
- 22 safety helmet
- 23 machinist's hammer
- 24 hand vice (*Am. vise*)
- 25 cape chisel (cross-cut chisel)
- 26 flat chisel
- 27 flat file
- 28 file cut (cut)
- 29 round file (*also:* half-round file)
- 30 tap wrench
- 31 reamer
- 32 die (die and stock)

33-35 key

- 33 stem (shank)
- 34 bow
- 35 bit

36-43 door lock, a mortise (mortice) lock

- 36 back plate
- 37 spring bolt (latch bolt)
- 38 tumbler
- 39 bolt
- 40 keyhole
- 41 bolt guide pin
- 42 tumbler spring
- 43 follower, with square hole
- 44 cylinder lock (safety lock)
- 45 cylinder (plug)
- 46 spring
- 47 pin
- 48 safety key, a flat key
- 49 lift-off hinge
- 50 hook-and-ride band
- 51 strap hinge

52 vernier calliper (caliper) gauge (*Am. gage*)

- 53 feeler gauge (*Am. gage*)
- 54 vernier depth gauge (*Am. gage*)
- 55 vernier

- 56 straightedge
- 57 square
- 58 breast drill
- 59 twist bit (twist drill)
- 60 screw tap (tap)
- 61 halves of a screw die
- 62 screwdriver
- 63 scraper (*also:* pointed triangle scraper)

- 64 centre (*Am. center*) punch
- 65 round punch
- 66 flat-nose pliers
- 67 detachable-jaw cut nippers
- 68 gas pliers
- 69 pincers

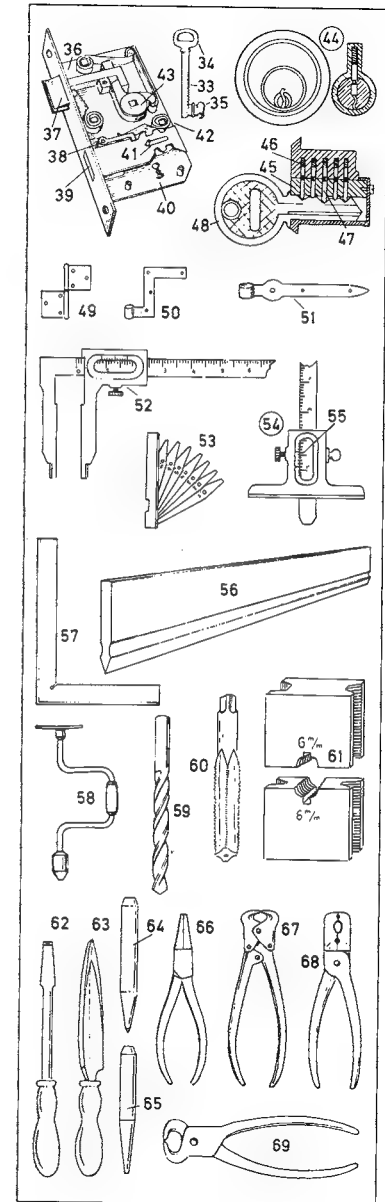

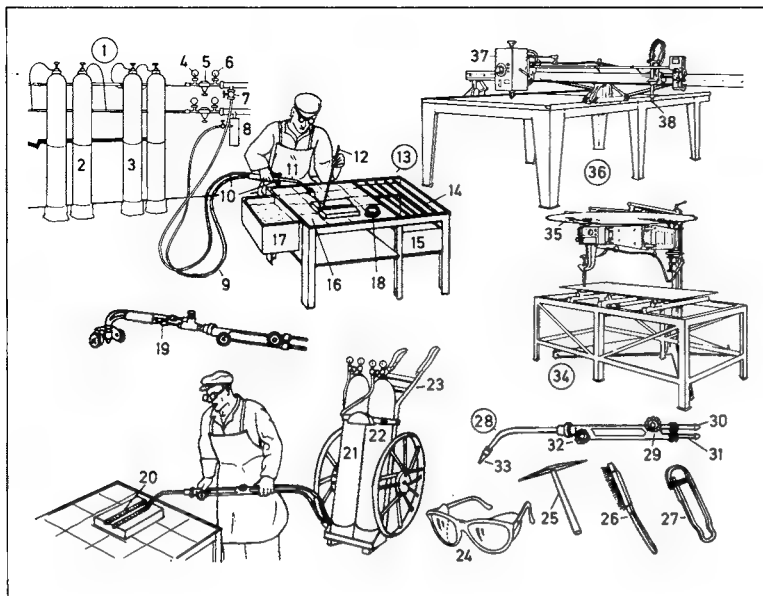

- | | |
|---|--|
| 1 gas cylinder manifold | 21 oxygen cylinder |
| 2 acetylene cylinder | 22 acetylene cylinder |
| 3 oxygen cylinder | 23 cylinder trolley |
| 4 high-pressure manometer | 24 welding goggles |
| 5 pressure-reducing valve (reducing valve, pressure regulator) | 25 chipping hammer |
| 6 low-pressure manometer | 26 wire brush |
| 7 stop valve | 27 torch lighter (blowpipe lighter) |
| 8 hydraulic back-pressure valve for low-pressure installations | 28 welding torch (blowpipe) |
| 9 gas hose | 29 oxygen control |
| 10 oxygen hose | 30 oxygen connection |
| 11 welding torch (blowpipe) | 31 gas connection (acetylene connection) |
| 12 welding rod (filler rod) | 32 gas control (acetylene control) |
| 13 welding bench | 33 welding nozzle |
| 14 grating | 34 cutting machine |
| 15 scrap box | 35 circular template |
| 16 bench covering of chamotte slabs | 36 universal cutting machine |
| 17 water tank | 37 tracing head |
| 18 welding paste (flux) | 38 cutting nozzle |
| 19 welding torch (blowpipe) with cutting attachment and guide tractor | |
| 20 workpiece | |

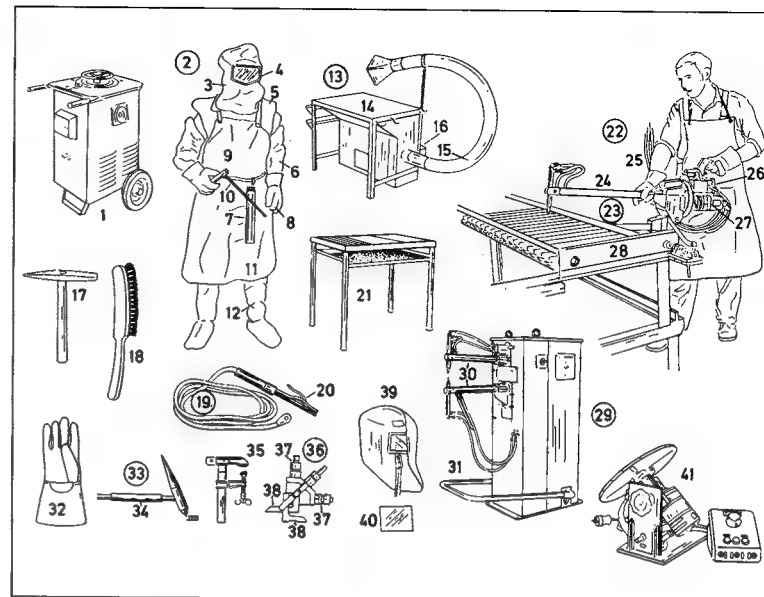

- | | |
|---|--|
| 1 welding transformer | 23 spot welding electrode holder |
| 2 arc welder | 24 electrode arm |
| 3 arc welding helmet | 25 power supply (lead) |
| 4 flip-up window | 26 electrode-pressure cylinder |
| 5 shoulder guard | 27 welding transformer |
| 6 protective sleeve | 28 workpiece |
| 7 electrode case | 29 foot-operated spot welder |
| 8 three-fingered welding glove | 30 welder electrode arms |
| 9 electrode holder | 31 foot pedal for welding pressure adjustment |
| 10 electrode | 32 five-fingered welding glove |
| 11 leather apron | 33 inert-gas torch for inert-gas welding (gas-shielded arc welding) |
| 12 shin guard | 34 inert-gas (shielding-gas) supply |
| 13 welding table with fume extraction equipment | 35 work clamp (earthing clamp) |
| 14 table top | 36 fillet gauge (Am. gage) (weld gauge) [for measuring throat thickness] |
| 15 movable extractor duct | 37 micrometer |
| 16 extractor support | 38 measuring arm |
| 17 chipping hammer | 39 arc welding helmet |
| 18 wire brush | 40 filter lens |
| 19 welding lead | 41 small turntable |
| 20 electrode holder | |
| 21 welding bench | |
| 22 spot welding | |

[material: steel, brass, aluminium (Am. aluminium), plastics, etc.; in the following, steel was chosen as an example]

- 1 angle iron (angle)
- 2 leg (flange)
- 3-7 **steel girders**
- 3 T-iron (tee-iron)
- 4 vertical leg
- 5 flange
- 6 H-girder (H-beam)
- 7 E-channel (channel iron)
- 8 round bar
- 9 square iron (Am. square stock)
- 10 flat bar
- 11 strip steel
- 12 iron wire
- 13-50 **screws and bolts**
- 13 hexagonal-head bolt
- 14 head
- 15 shank
- 16 thread
- 17 washer
- 18 hexagonal nut
- 19 split pin
- 20 rounded end
- 21 width of head (of flats)
- 22 stud
- 23 point (end)
- 24 castle nut (castellated nut)
- 25 hole for the split pin
- 26 cross-head screw, a sheet-metal screw (self-tapping screw)
- 27 hexagonal socket head screw
- 28 countersunk-head bolt
- 29 catch
- 30 locknut (locking nut)
- 31 bolt (pin)
- 32 collar-head bolt
- 33 set collar (integral collar)
- 34 spring washer (washer)
- 35 round nut, an adjusting nut
- 36 cheese-head screw, a slotted screw
- 37 tapered pin
- 38 screw slot (screw slit, screw groove)
- 39 square-head bolt
- 40 grooved pin, a cylindrical pin
- 41 T-head bolt
- 42 wing nut (fly nut, butterfly nut)
- 43 rag bolt
- 44 barb
- 45 wood screw
- 46 countersunk head
- 47 wood screw thread
- 48 grub screw
- 49 pin slot (pin slit, pin groove)
- 50 round end
- 51 nail (wire nail)
- 52 head
- 53 shank
- 54 point
- 55 roofing nail

- 56 riveting (lap riveting)
- 57-60 **rivet**
- 57 set head (swage head, die head), a rivet head
- 58 rivet shank
- 59 closing head
- 60 pitch of rivets
- 61 **shaft**
- 62 chamfer (bevel)
- 63 journal
- 64 neck
- 65 seat
- 66 keyway
- 67 conical seat (cone)
- 68 thread
- 69 **ball bearing**, an antifriction bearing
- 70 steel ball (ball)
- 71 outer race
- 72 inner race
- 73, 74 **keys**
- 73 sunk key (feather)
- 74 gib (gib-headed key)
- 75, 76 **needle roller bearing**
- 75 needle cage
- 76 needle
- 77 castle nut (castellated nut)
- 78 split pin
- 79 casing
- 80 casing cover
- 81 grease nipple (lubricating nipple)
- 82-96 **gear wheels, cog wheels**
- 82 stepped gear wheel
- 83 cog (tooth)
- 84 space between teeth
- 85 keyway (key seat, key slot)
- 86 bore
- 87 herringbone gear wheel
- 88 spoke (arm)
- 89 helical gearing (helical spur wheel)
- 90 sprocket
- 91 bevel gear wheel (bevel wheel)
- 92, 93 **spiral toothing**
- 92 pinion
- 93 crown wheel
- 94-96 **epicyclic gear (planetary gear)**
- 94 planet wheels
- 95 internal gear
- 96 sun wheel (sun gear)
- 97-107 **absorption dynamometer**
- 97 shoe brake (check brake, block brake)
- 98 brake pulley
- 99 brake shaft (brake axle)
- 100 brake block (brake shoe)
- 101 pull rod
- 102 brake magnet
- 103 brake weight
- 104 band brake
- 105 brake band
- 106 brake lining
- 107 adjusting screw, for even application of the brake

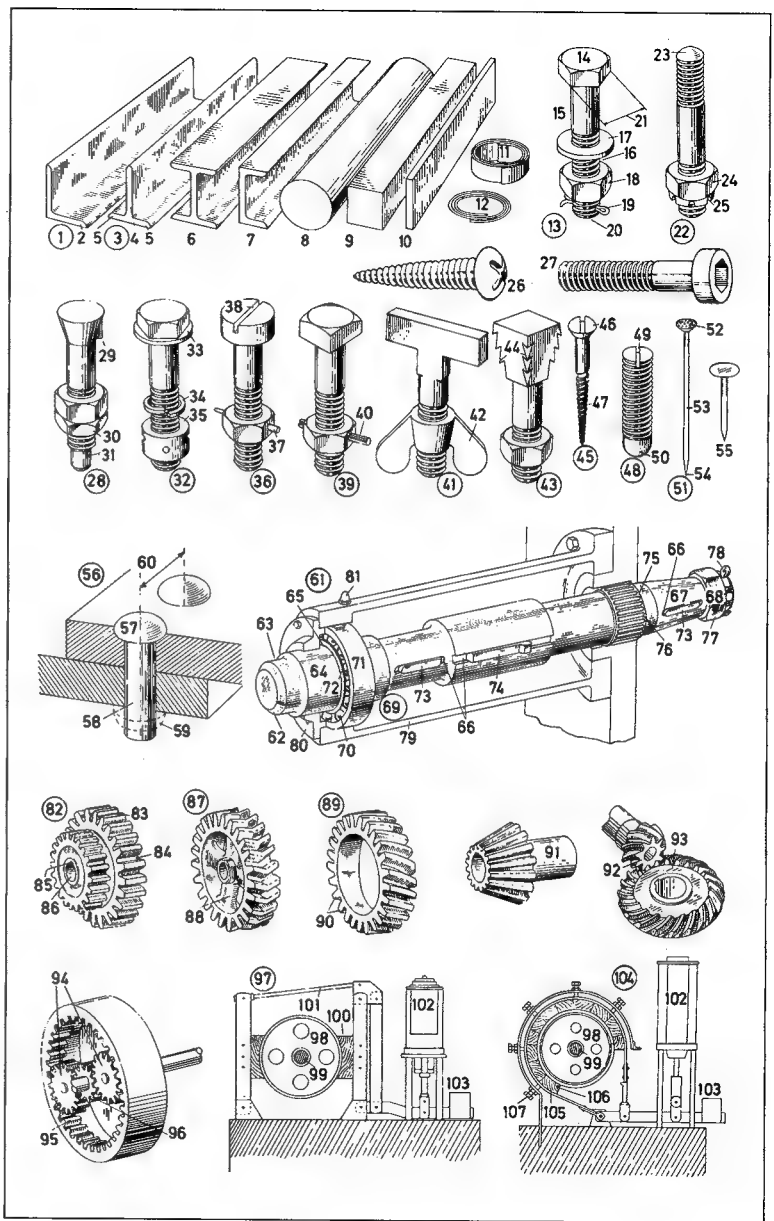

- 1-51 coal mine (colliery, pit)
- 1 pithead gear (headgear)
- 2 winding engine house
- 3 pithead frame (head frame)
- 4 pithead building
- 5 processing plant
- 6 sawmill
- 7-11 coking plant
- 7 battery of coke ovens
- 8 larry car (larry, charging car)
- 9 coking coal tower
- 10 coke-quenching tower
- 11 coke-quenching car
- 12 gasometer
- 13 power plant (power station)
- 14 water tower
- 15 cooling tower
- 16 mine fan
- 17 depot
- 18 administration building (office building, offices)
- 19 tip heap (spoil heap)
- 20 cleaning plant
- 21-51 underground workings (underground mining)
- 21 ventilation shaft
- 22 fan drift
- 23 cage-winding system with cages
- 24 main shaft
- 25 skip-winding system
- 26 winding inset
- 27 staple shaft
- 28 spiral chute
- 29 gallery along seam
- 30 lateral
- 31 cross-cut
- 32 tunnelling (*Am.* tunneling) machine
- 33-37 longwall faces
- 33 horizontal ploughed longwall face
- 34 horizontal cut longwall face
- 35 vertical pneumatic pick longwall face
- 36 diagonal ram longwall face
- 37 goaf (gob, waste)
- 38 air lock
- 39 transportation of men by cars

- 40 belt conveying
- 41 raw coal bunker
- 42 charging conveyor
- 43 transportation of supplies by monorail car
- 44 transportation of men by monorail car
- 45 transportation of supplies by mine car
- 46 drainage
- 47 sump (sink)
- 48 capping
- 49 [layer of] coal-bearing rock
- 50 coal seam
- 51 fault

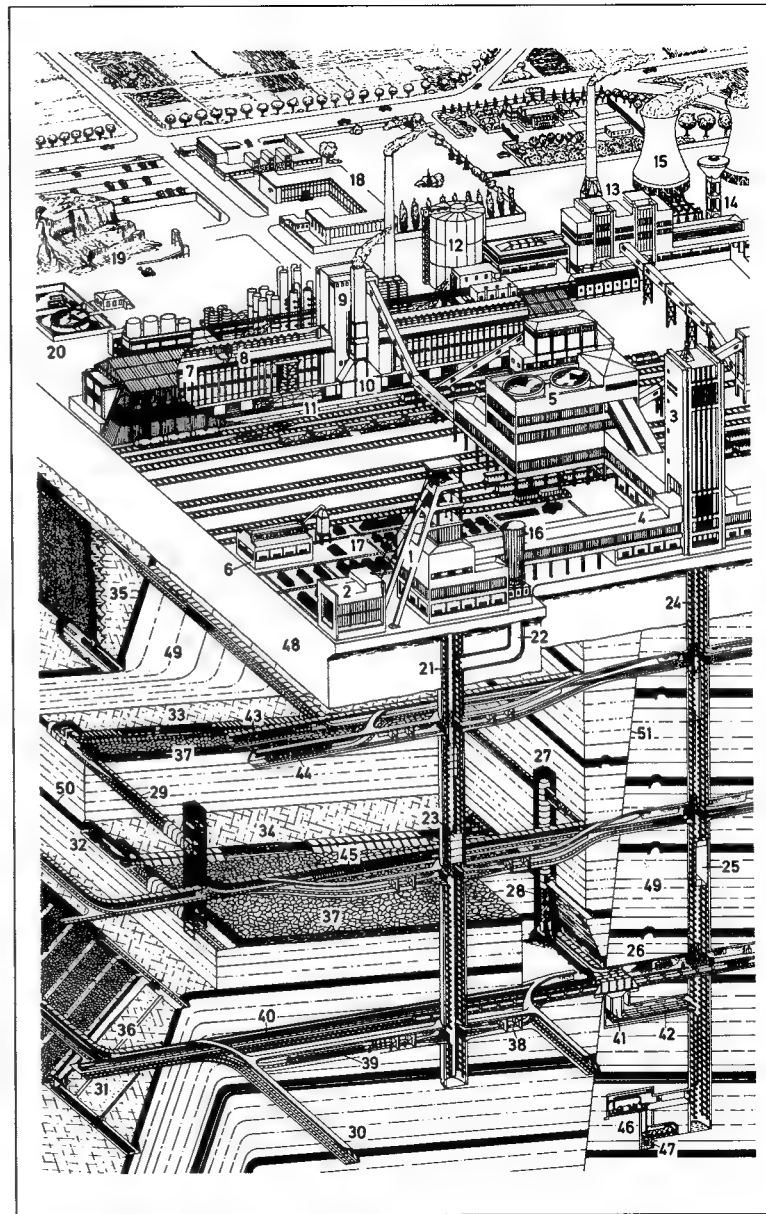

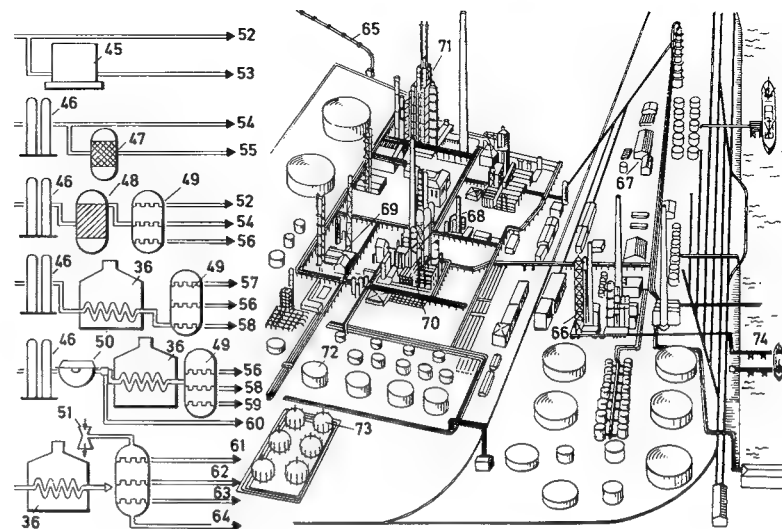
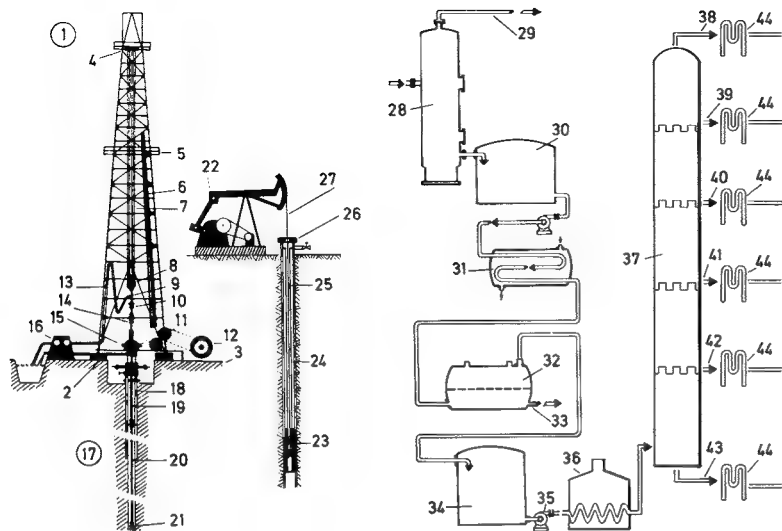
**1-21 oil drilling**

- 1 drilling rig
- 2 substructure
- 3 crown safety platform
- 4 crown blocks
- 5 working platform, an intermediate platform
- 6 drill pipes
- 7 drilling cable (drilling line)
- 8 travelling (*Am.* traveling) block
- 9 hook
- 10 [rotary] swivel
- 11 hoist
- 12 engine
- 13 standpipe and rotary hose
- 14 kelly
- 15 rotary table
- 16 slush pump (mud pump)
- 17 well
- 18 casing
- 19 drilling pipe
- 20 tubing
- 21 drilling bit; *kinds:* fishtail (blade) bit, rock (*Am.* roller) bit, core bit

22-27 oil (crude oil) production

- 22 pumping unit (pump)
- 23 plunger
- 24 tubing
- 25 sucker rods (pumping rods)
- 26 stuffing box
- 27 polish (polished) rod
- 28-35 **treatment of crude oil** [diagram]
- 28 gas separator
- 29 gas pipe (gas outlet)
- 30 wet oil tank (wash tank)
- 31 water heater
- 32 water and brine separator
- 33 salt water pipe (salt water outlet)
- 34 oil tank
- 35 trunk pipeline for oil [to the refinery or transport by tanker lorry (*Am.* tank truck), oil tanker or pipeline]

36-64 processing of crude oil [diagram]

- 36 oil furnace (pipe still)
- 37 fractionating column (distillation column) with trays
- 38 top gases (tops)

- 39 light distillation products
- 40 heavy distillation products
- 41 petroleum
- 42 gas oil component
- 43 residue
- 44 condenser (cooler)
- 45 compressor
- 46 desulphurizing (desulphurization, *Am.* desulfurizing, desulfurization) plant
- 47 reformer (hydroformer, platformer)
- 48 catalytic cracker (cat cracker)
- 49 distillation column
- 50 de-waxing (wax separation)
- 51 vacuum equipment
- 52-64 **oil products**
- 52 fuel gas
- 53 liquefied petroleum gas (liquid gas)
- 54 regular grade petrol (*Am.* gasoline)
- 55 super grade petrol (*Am.* gasoline)
- 56 diesel oil

- 57 aviation fuel
- 58 light fuel oil
- 59 heavy fuel oil
- 60 paraffin (paraffin oil, kerosene)
- 61 spindle oil
- 62 lubricating oil
- 63 cylinder oil
- 64 bitumen
- 65-74 **oil refinery**
- 65 pipeline (oil pipeline)
- 66 distillation plants
- 67 lubricating oil refinery
- 68 desulphurizing (desulphurization, *Am.* desulfurizing, desulfurization) plant
- 69 gas-separating plant
- 70 catalytic cracking plant
- 71 catalytic reformer
- 72 storage tank
- 73 spherical tank
- 74 tanker terminal

146 Offshore Drilling

1-39 drilling rig (oil rig)

1-37 drilling platform

- 1 power station
- 2 generator exhausts
- 3 revolving crane (pedestal crane)
- 4 piperack
- 5 turbine exhausts
- 6 materials store
- 7 helicopter deck (heliport deck, heliport)
- 8 elevator
- 9 production oil and gas separator
- 10 test oil and gas separators (test separators)
- 11 emergency flare stack
- 12 derrick
- 13 diesel tank
- 14 office building
- 15 cement storage tanks
- 16 drinking water tank
- 17 salt water tank
- 18 jet fuel tanks
- 19 lifeboats
- 20 elevator shaft
- 21 compressed-air reservoir
- 22 pumping station
- 23 air compressor
- 24 air lock
- 25 seawater desalination plant
- 26 inlet filters for diesel fuel
- 27 gas cooler
- 28 control panel for the separators
- 29 toilets (lavatories)
- 30 workshop
- 31 pig trap [the 'pig' is used to clean the oil pipeline]
- 32 control room
- 33 accommodation modules (accommodation)
- 34 high-pressure cementing pumps
- 35 lower deck
- 36 middle deck
- 37 top deck (main deck)
- 38 substructure
- 39 mean sea level

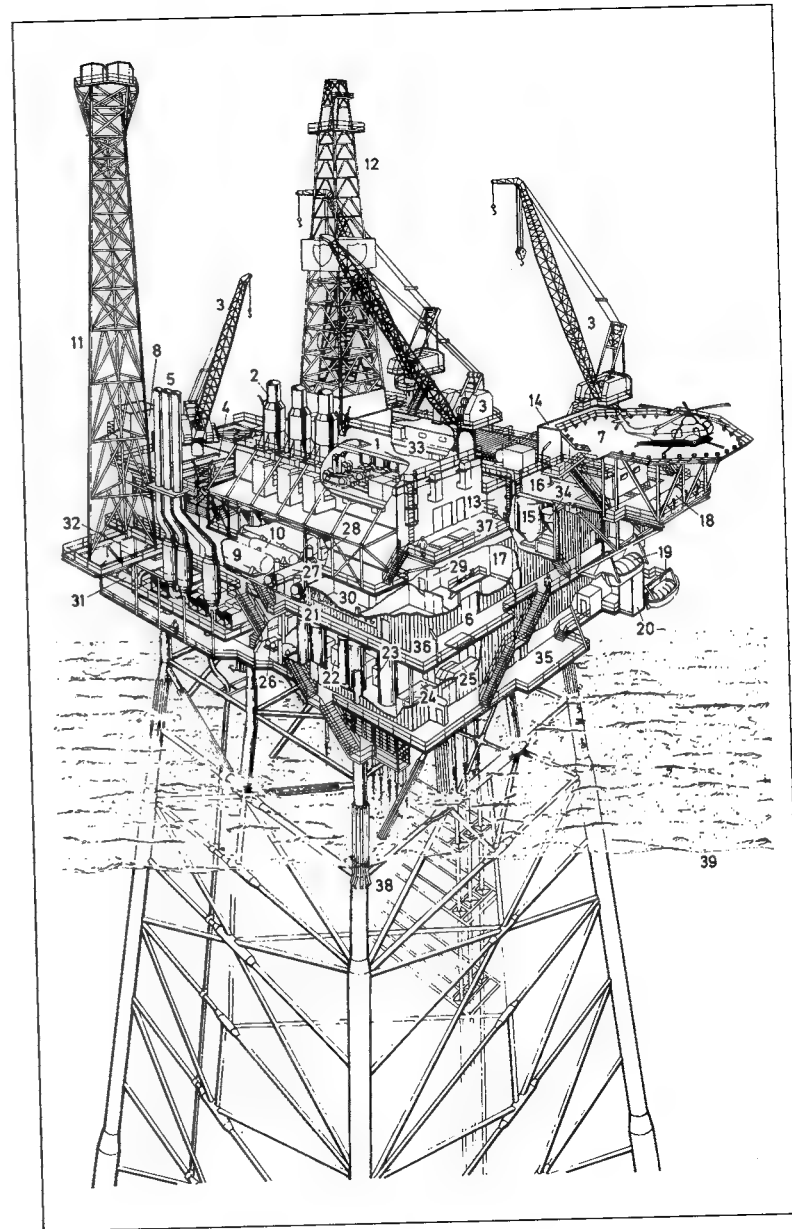

1-20 blast furnace plant

- 1 blast furnace, a shaft furnace
- 2 furnace incline (lift) for ore and flux or coke
- 3 skip hoist
- 4 charging platform
- 5 receiving hopper
- 6 bell
- 7 blast furnace shaft
- 8 smelting section
- 9 slag escape
- 10 slag ladle
- 11 pig iron (crude iron, iron) runout
- 12 pig iron (crude iron, iron) ladle
- 13 downtake
- 14 dust catcher, a dust-collecting machine
- 15 hot-blast stove
- 16 external combustion chamber
- 17 blast main
- 18 gas pipe
- 19 hot-blast pipe
- 20 tuyère

21-69 steelworks**21-30 Siemens-Martin open-hearth furnace**

- 21 pig iron (crude iron, iron) ladle
- 22 feed runner
- 23 stationary furnace
- 24 hearth
- 25 charging machine
- 26 scrap iron charging box
- 27 gas pipe
- 28 gas regenerator chamber
- 29 air feed pipe
- 30 air regenerator chamber
- 31 [bottom-pouring] steel-casting ladle with stopper
- 32 ingot mould (*Am.* mold)
- 33 steel ingot
- 34-44 pig-casting machine**
- 34 pouring end
- 35 metal runner
- 36 series (strand) of moulds (*Am.* molds)
- 37 mould (*Am.* mold)
- 38 catwalk

- 39 discharging chute
- 40 pig
- 41 travelling (*Am.* traveling) crane
- 42 top-pouring pig iron (crude iron, iron) ladle
- 43 pouring ladle lip
- 44 tilting device (tipping device, *Am.* dumping device)
- 45-50 oxygen-blowing converter (L-D converter, Linz-Donawitz converter)**
- 45 conical converter top
- 46 mantle
- 47 solid converter bottom
- 48 fireproof lining (refractory lining)
- 49 oxygen lance
- 50 tapping hole (tap hole)
- 51-54 Siemens electric low-shaft furnace**
- 51 feed
- 52 electrodes [arranged in a circle]
- 53 bustle pipe
- 54 runout
- 55-69 Thomas converter (basic Bessemer converter)**
- 55 charging position for molten pig iron
- 56 charging position for lime
- 57 blow position
- 58 discharging position
- 59 tilting device (tipping device, *Am.* dumping device)
- 60 crane-operated ladle
- 61 auxiliary crane hoist
- 62 lime bunker
- 63 downpipe
- 64 tipping car (*Am.* dump truck)
- 65 scrap iron feed
- 66 control desk
- 67 converter chimney
- 68 blast main
- 69 wind box

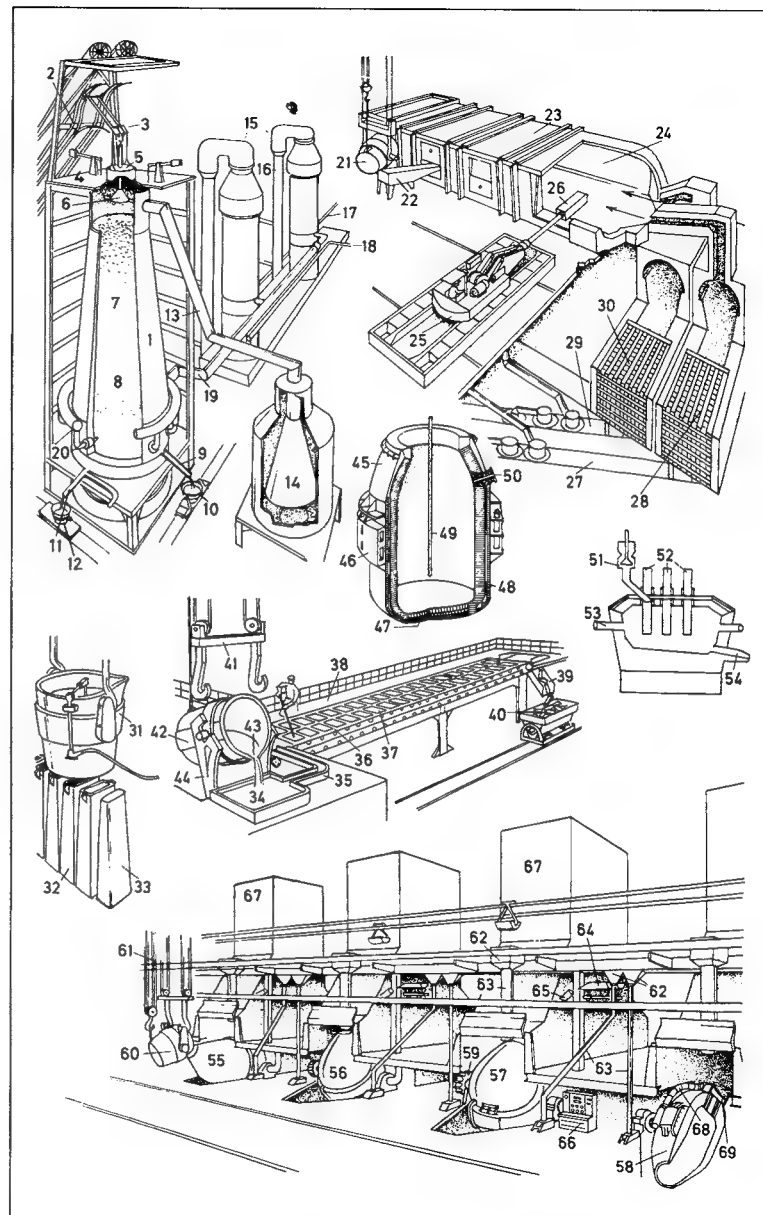

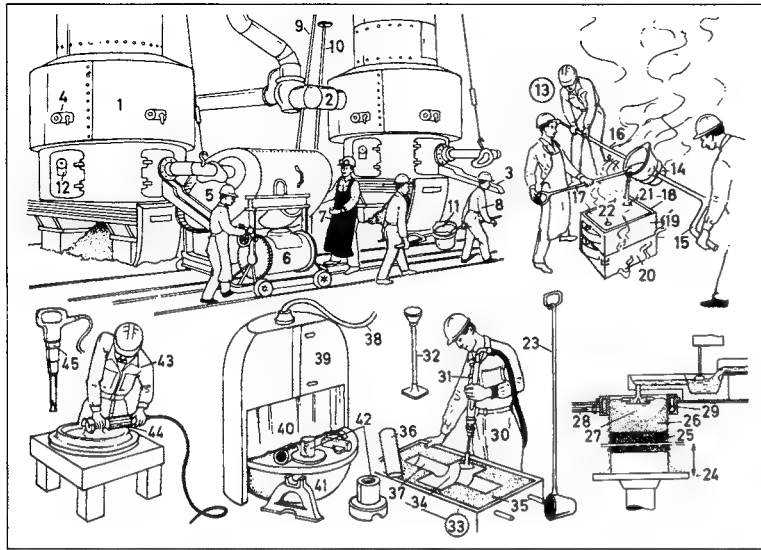
**1-45 iron foundry****1-12 melting plant**

- 1 cupola furnace (cupola), a melting furnace
- 2 blast main (blast inlet, blast pipe)
- 3 tapping spout
- 4 spyhole
- 5 tilting-type [hot-metal] receiver
- 6 mobile drum-type ladle
- 7 melter
- 8 founder (caster)
- 9 tap bar (tapping bar)
- 10 bott stick (*Am.* bot stick)
- 11 molten iron
- 12 slag spout
- 13 casting team
- 14 hand shank
- 15 double handle (crutch)
- 16 carrying bar
- 17 skimmer rod
- 18 closed moulding (*Am.* moulding) box
- 19 upper frame (cope)
- 20 lower frame (drag)
- 21 runner (runner gate, down-gate)

22 riser (riser gate)**23 hand ladle****24-29 continuous casting**

- 24 sinking pouring floor
- 25 solidifying pig
- 26 solid stage
- 27 liquid stage
- 28 water-cooling system
- 29 mould (*Am.* mold) wall
- 30-37 moulding (*Am.* molding) department (moulding shop)**
- 30 moulder (*Am.* molder)
- 31 pneumatic rammer
- 32 hand rammer
- 33 open moulding (*Am.* molding) box
- 34 pattern
- 35 moulding (*Am.* molding) sand
- 36 core
- 37 core print
- 38-45 cleaning shop (fettling shop)**
- 38 steel grit or sand delivery pipe
- 39 rotary-table shot-blasting machine
- 40 grit guard
- 41 revolving table
- 42 casting

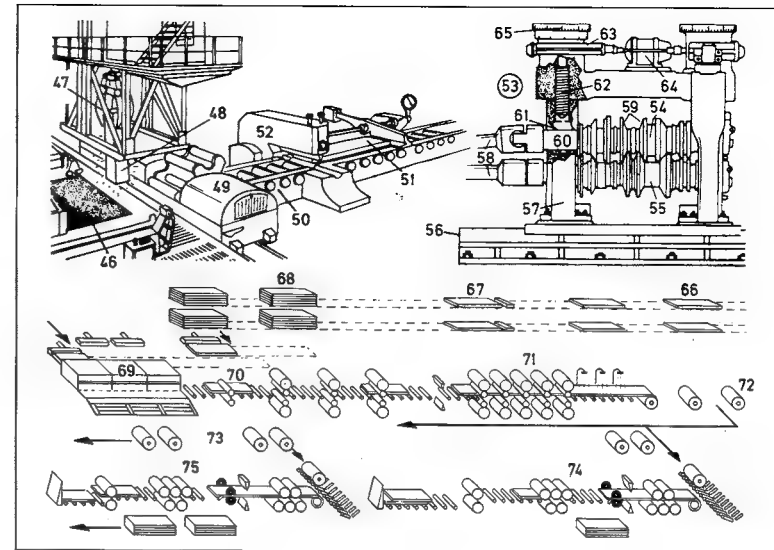
**43 fettler****44 pneumatic grinder****45 pneumatic chisel****46-75 rolling mill**

- 46 soaking pit
- 47 soaking pit crane
- 48 ingot
- 49 ingot tipper
- 50 roller table
- 51 workpiece
- 52 bloom shears
- 53 two-high mill
- 54 upper roll (upper roller)
- 55 lower roll (lower roller)
- 56-60 roll stand**
- 56 base plate
- 57 housing (frame)
- 58 coupling spindle
- 59 groove
- 60 roll bearing
- 61-65 adjusting equipment**
- 61 chock
- 62 main screw
- 63 gear

64 motor**65 indicator for rough and fine adjustment****66-75 continuous rolling mill train for the manufacture of strip [diagram]**

- 66-68 processing of semi-finished product
- 66 semi-finished product
- 67 gas cutting installation
- 68 stack of finished steel sheets
- 69 continuous reheating furnaces
- 70 blooming train
- 71 finishing train
- 72 coiler
- 73 stock of coils for sale
- 74 5 mm shearing train
- 75 10 mm shearing train

- 1 centre (*Am.* center) lathe
- 2 headstock with gear control (geared headstock)
- 3 reduction drive lever
- 4 lever for normal and coarse threads
- 5 speed change lever
- 6 leadscrew reverse-gear lever
- 7 change-gear box
- 8 feed gearbox (Norton tumbler gear)
- 9 levers for changing the feed and thread pitch
- 10 feed gear lever (tumbler lever)
- 11 switch lever for right or left hand action of main spindle
- 12 lathe foot (footpiece)
- 13 leadscrew handwheel for traversing of saddle (longitudinal movement of saddle)
- 14 tumbler reverse lever
- 15 feed screw
- 16 apron (saddle apron, carriage apron)
- 17 lever for longitudinal and transverse motion
- 18 drop (dropping) worm (feed trip, feed tripping device) for engaging feed mechanisms
- 19 lever for engaging half nut of lead-screw (lever for clasp nut engagement)
- 20 lathe spindle
- 21 tool post
- 22 top slide (tool slide, tool rest)
- 23 cross slide
- 24 bed slide
- 25 coolant supply pipe
- 26 tailstock centre (*Am.* center)
- 27 barrel (tailstock barrel)
- 28 tailstock barrel clamp lever
- 29 tailstock
- 30 tailstock barrel adjusting handwheel
- 31 lathe bed
- 32 leadscrew
- 33 feed shaft
- 34 reverse shaft for right and left hand motion and engaging and disengaging
- 35 four-jaw chuck (four-jaw independent chuck)
- 36 gripping jaw
- 37 three-jaw chuck (three-jaw self-centering, *Am.* self-centering, chuck)
- 38 turret lathe

- 39 cross slide
- 40 turret
- 41 combination toolholder (multiple turning head)
- 42 top slide
- 43 star wheel
- 44 coolant tray for collecting coolant and swarf
- 45-53 lathe tools
- 45 tool bit holder (clamp tip tool) for adjustable cutting tips
- 46 adjustable cutting tip (clamp tip) of cemented carbide or oxide ceramic shapes of adjustable oxide ceramic tips
- 47 lathe tool with cemented carbide cutting edge
- 48 tool shank
- 49 brazed cemented carbide cutting tip (cutting edge)
- 50 internal facing tool (boring tool) for corner work
- 51 general-purpose lathe tool
- 52 parting (parting-off) tool
- 53 lathe carrier
- 54 driving (driver) plate
- 56-72 measuring instruments
- 56 plug gauge (*Am.* gage)
- 57 'GO' gauging (*Am.* gaging) member (end)
- 58 'NOT GO' gauging (*Am.* gaging) member (end)
- 59 calliper (caliper, snap) gauge (*Am.* gage)
- 60 'GO' side
- 61 'NOT GO' side
- 62 micrometer
- 63 measuring scale
- 64 graduated thimble
- 65 frame
- 66 spindle (screwed spindle)
- 67 vernier calliper (caliper) gauge (*Am.* gage)
- 68 depth gauge (*Am.* gage) attachment rule
- 69 vernier scale
- 70 outside jaws
- 71 inside jaws
- 72 vernier depth gauge (*Am.* gage)

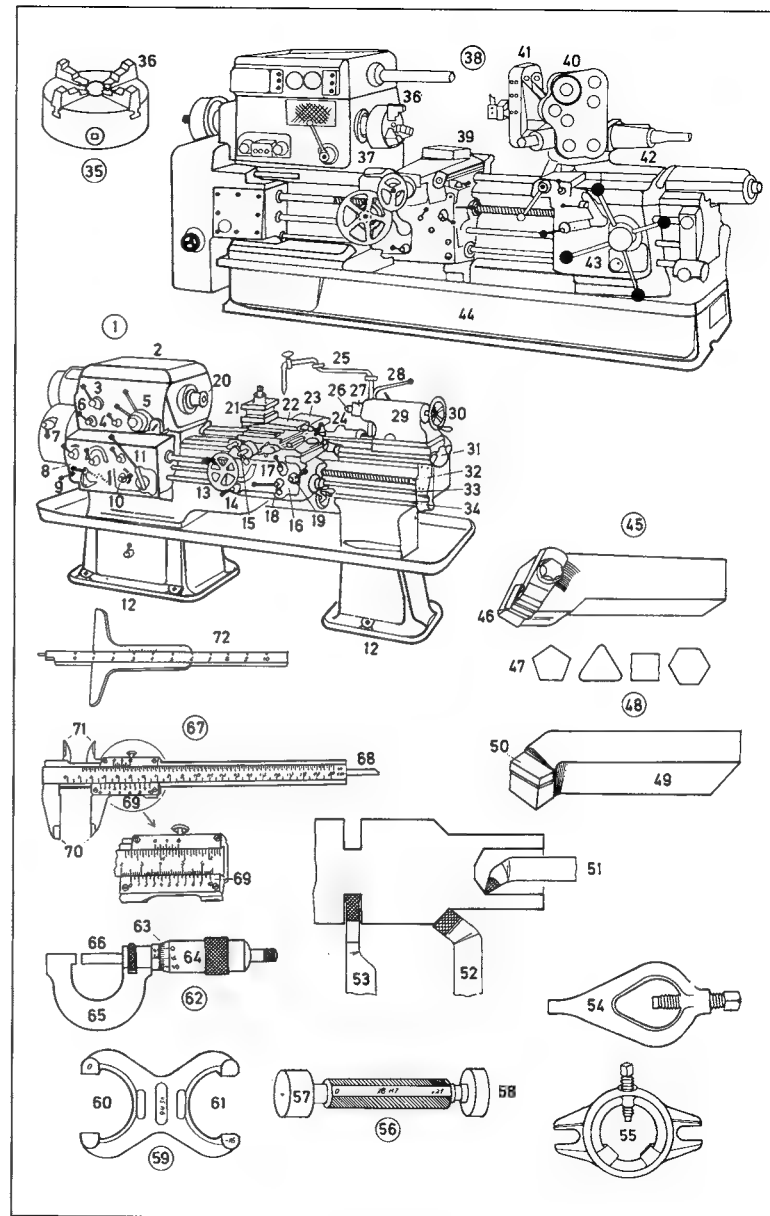

- 1 universal grinding machine
- 2 headstock
- 3 wheelhead slide
- 4 grinding wheel
- 5 tailstock
- 6 grinding machine bed
- 7 grinding machine table
- 8 two-column planing machine (two-column planer)
- 9 drive motor, a direct current motor
- 10 column
- 11 planer table
- 12 cross slide (rail)
- 13 tool box
- 14 hacksaw
- 15 clamping device
- 16 saw blade
- 17 saw frame
- 18 radial (radial-arm) drilling machine
- 19 bed (base plate)
- 20 block for workpiece
- 21 pillar
- 22 lifting motor
- 23 drill spindle
- 24 arm
- 25 universal milling machine
- 26 milling machine table
- 27 table feed drive
- 28 switch lever for spindle rotation speed
- 29 control box (control unit)
- 30 vertical milling spindle
- 31 vertical drive head
- 32 horizontal milling spindle
- 33 end support for steadying horizontal spindle
- 34 machine tap
- 35 articulated robot, an industrial robot
- 36 base plate
- 37 rotating column (base rotating axis)
- 38 shoulder joint
- 39 upper arm
- 40 elbow joint
- 41 tubular forearm

- 42 wrist joint
- 43 gripper mounting flange
- 44 gripper
- 45 fingers
- 46 upright robot (linear-axis robot, rectilinear robot)
- 47 portal robot (gantry robot)

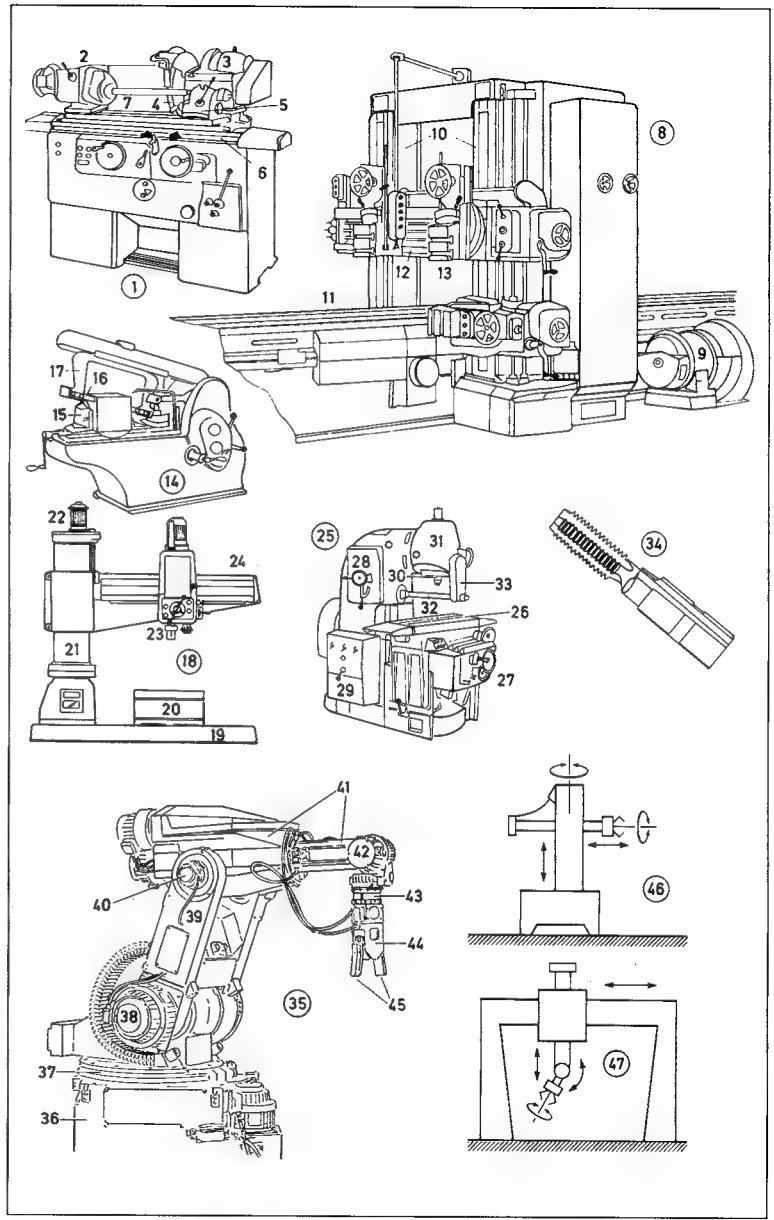

- 1 drawing board
- 2 drafting machine with parallel motion
- 3 adjustable knob
- 4 drawing head (adjustable set square)
- 5 drawing board adjustment
- 6 drawing table
- 7 set square (triangle)
- 8 triangle
- 9 T-square (tee-square)
- 10 rolled drawing
- 11 diagram
- 12 time schedule
- 13 paper stand
- 14 roll of paper
- 15 cutter
- 16 technical drawing (drawing, design)
- 17 front view (front elevation)
- 18 side view (side elevation)
- 19 plan
- 20 surface not to be machined
- 21 surface to be machined
- 22 surface to be superfinished
- 23 visible edge
- 24 hidden edge
- 25 dimension line
- 26 arrow head
- 27 section line
- 28 section A-B
- 29 hatched surface
- 30 centre (*Am.* center) line
- 31 title panel (title block)
- 32 technical data
- 33 ruler (rule)
- 34 triangular scale
- 35 erasing shield
- 36 drawing ink cartridge
- 37 holders for tubular drawing pens
- 38 set of tubular drawing pens
- 39 hygrometer
- 40 cap with indication of nib size
- 41 pencil-type eraser
- 42 eraser
- 43 erasing knife
- 44 erasing knife blade

- 45 clutch-type pencil
- 46 pencil lead (refill lead, refill, spare lead)
- 47 glass eraser
- 48 glass fibres (*Am.* fibers)
- 49 ruling pen
- 50 cross joint
- 51 index plate
- 52 compass with interchangeable attachments
- 53 compass head
- 54 needle point attachment
- 55 pencil point attachment
- 56 needle
- 57 lengthening arm (extension bar)
- 58 ruling pen attachment
- 59 pump compass (drop compass)
- 60 piston
- 61 ruling pen attachment
- 62 pencil attachment
- 63 drawing ink container
- 64 spring bow (rapid adjustment, ratchet-type) compass
- 65 spring ring hinge
- 66 spring-loaded fine adjustment for arcs
- 67 right-angle needle
- 68 tubular ink unit
- 69 stencil lettering guide (lettering stencil)
- 70 circle template
- 71 ellipse template

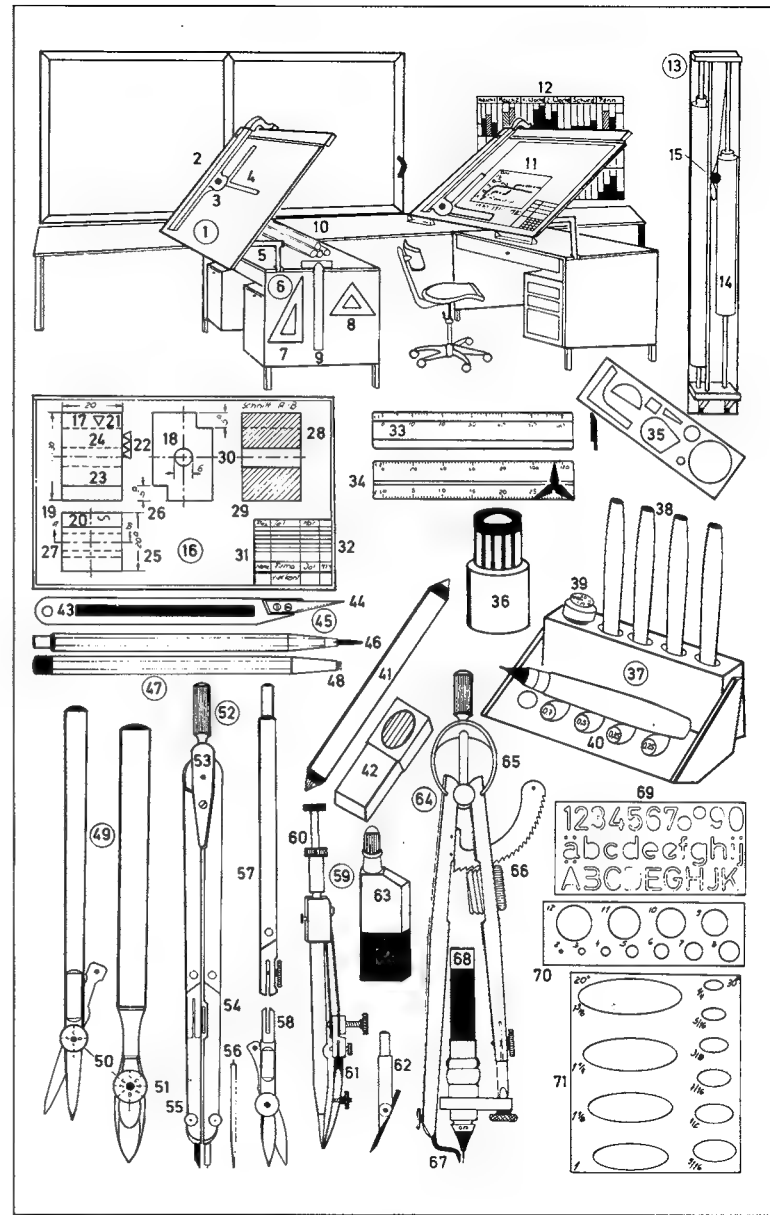

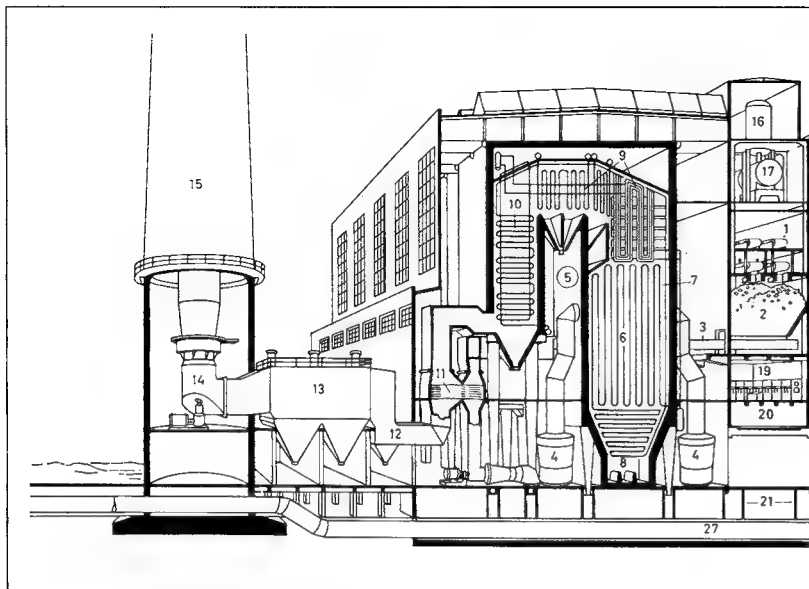

1-28 steam-generating station, an electric power plant

1-21 boiler house

1 coal conveyor

2 coal bunker

3 travelling-grate (*Am.* traveling-grate) stoker

4 coal mill

5 steam boiler, a water-tube boiler (radiant-type boiler)

6 burners

7 water pipes

8 ash pit (clinker pit)

9 superheater

10 water preheater

11 air preheater

12 gas flue

13 electrostatic precipitator

14 induced-draught (*Am.* induced-draft) fan

15 chimney (smokestack)

16 de-aerator

17 feedwater tank

18 boiler feed pump

19 control room

20 cable tunnel

21 cable vault

22 turbine house

23 steam turbine with alternator

24 surface condenser

25 low-pressure preheater

26 high-pressure preheater (economizer)

27 cooling water pipe

28 control room

29-35 outdoor substation, a substation

29 busbars

30 power transformer, a mobile (transportable) transformer

31 stay poles (guy poles)

32 high-voltage transmission line

33 high-voltage conductor

34 air-blast circuit breaker (circuit breaker)

35 surge diverter (*Am.* lightning arrester, arrester)

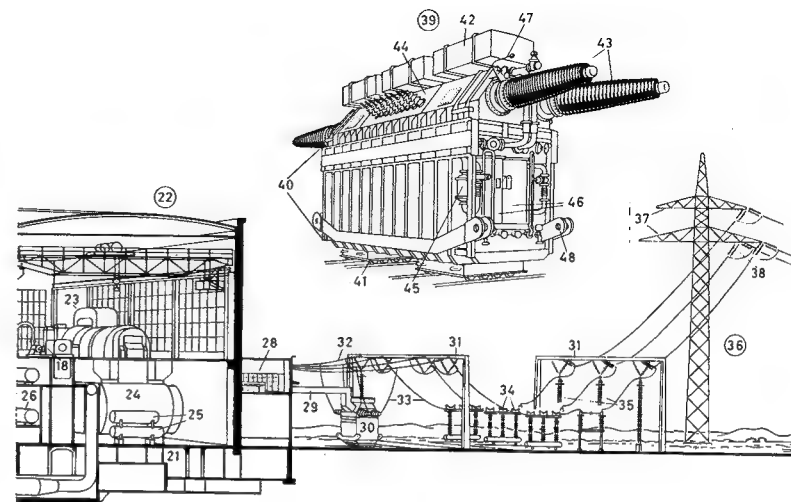

36 overhead line support, a lattice steel tower

37 cross arm (traverse)

38 strain insulator

39 **mobile (transportable) transformer** (power transformer, transformer)

40 transformer tank

41 bogie (*Am.* truck)

42 oil conservator

43 primary voltage terminal (primary voltage bushing)

44 low-voltage terminals (low-voltage bushings)

45 oil-circulating pump

46 oil cooler

47 arcing horn

48 transport lug

1-8 control room

- 1-6 **control console** (control desk)
- 1 control board (control panel) for the alternators
- 2 master switch
- 3 signal light
- 4 feeder panel
- 5 monitoring controls for the switching systems
- 6 controls
- 7 revertive signal panel
- 8 matrix mimic board
- 9-18 transformer**
- 9 oil conservator
- 10 breather
- 11 oil gauge (*Am. gage*)
- 12 feed-through terminal (feed-through insulator)
- 13 on-load tap changer
- 14 yoke
- 15 primary winding (primary)
- 16 secondary winding (secondary, low-voltage winding)
- 17 core
- 18 tap (tapping)
- 19 **transformer connection**
- 20 star connection (star network, Y-connection)
- 21 delta connection (mesh connection)
- 22 neutral point
- 23-30 **steam turbine**, a turbogenerator unit
- 23 high-pressure cylinder
- 24 medium-pressure cylinder
- 25 low-pressure cylinder
- 26 three-phase generator (generator)
- 27 hydrogen cooler
- 28 leakage steam path
- 29 jet nozzle
- 30 turbine monitoring panel with measuring instruments
- 31 automatic voltage regulator
- 32 synchro
- 33 **cable box**
- 34 conductor

- 35 feed-through terminal (feed-through insulator)
- 36 core
- 37 casing
- 38 filling compound (filler)
- 39 lead sheath
- 40 lead-in tube
- 41 cable
- 42 **high voltage cable**, for three-phase current
- 43 conductor
- 44 metallic paper (metallized paper)
- 45 tracer (tracer element)
- 46 varnished-cambric tape
- 47 lead sheath
- 48 asphalted paper
- 49 jute serving
- 50 steel tape or steel wire armour (*Am. armor*)
- 51-62 **air-blast circuit breaker**, a circuit breaker
- 51 compressed-air tank
- 52 control valve (main operating valve)
- 53 compressed-air inlet
- 54 support insulator, a hollow porcelain supporting insulator
- 55 interrupter
- 56 resistor
- 57 auxiliary contacts
- 58 current transformer
- 59 voltage transformer (potential transformer)
- 60 operating mechanism housing
- 61 arcing horn
- 62 spark gap

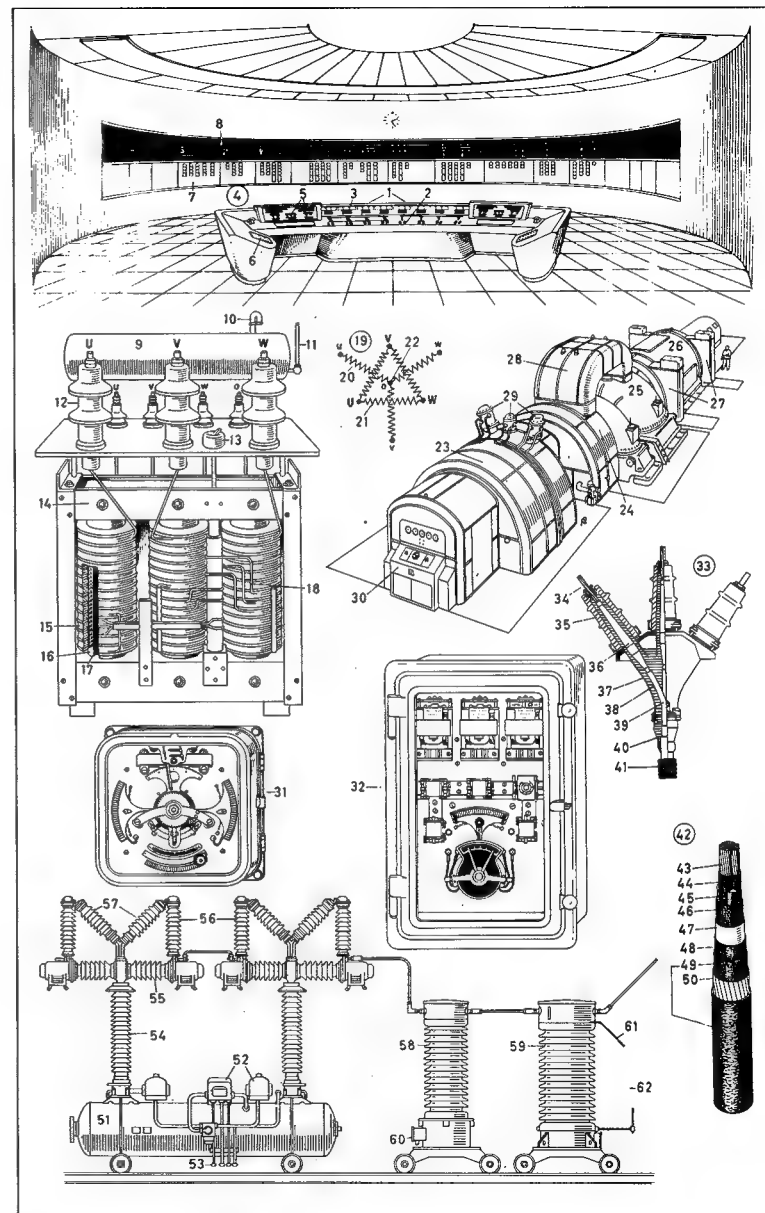

- 1 fast-breeder reactor (fast breeder) [diagram]
- 2 primary circuit (primary loop, primary sodium system)
- 3 reactor
- 4 fuel rods (fuel pins)
- 5 primary sodium pump
- 6 heat exchanger
- 7 secondary circuit (secondary loop, secondary sodium system)
- 8 secondary sodium pump
- 9 steam generator
- 10 cooling water flow circuit
- 11 steam line
- 12 feedwater line
- 13 feed pump
- 14 steam turbine
- 15 generator
- 16 transmission line
- 17 condenser
- 18 cooling water
- 19 nuclear reactor, a pressurized-water reactor (nuclear power plant, atomic power plant)
- 20 concrete shield (reactor building)
- 21 steel containment (steel shell) with air extraction vent
- 22 reactor pressure vessel
- 23 control rod drive
- 24 control rods
- 25 primary coolant pump
- 26 steam generator
- 27 fuel-handling hoists
- 28 fuel storage
- 29 coolant flow passage
- 30 feedwater line
- 31 prime steam line
- 32 manway
- 33 turbogenerator set
- 34 turbogenerator
- 35 condenser
- 36 service building
- 37 exhaust gas stack
- 38 polar crane
- 39 cooling tower, a dry cooling tower
- 40 pressurized-water system
- 41 reactor
- 42 primary circuit (primary loop)
- 43 circulation pump (recirculation pump)
- 44 heat exchanger (steam generator)

- 45 secondary circuit (secondary loop, feedwater steam circuit)
- 46 steam turbine
- 47 generator
- 48 cooling system
- 49 boiling water system [diagram]
- 50 reactor
- 51 steam and recirculation water flow paths
- 52 steam turbine
- 53 generator
- 54 circulation pump (recirculation pump)
- 55 coolant system (cooling with water from river)
- 56 radioactive waste storage in salt mine
- 57-68 geological structure of abandoned salt mine converted for disposal of radioactive waste (nuclear waste)
- 57 Lower Keuper
- 58 Upper Muschelkalk
- 59 Middle Muschelkalk
- 60 Lower Muschelkalk
- 61 Bunter downthrow
- 62 residue of leached (lixiviated) Zechstein (Upper Permian)
- 63 Aller rock salt
- 64 Leine rock salt
- 65 Stassfurt seam (potash salt seam, potash salt bed)
- 66 Stassfurt salt
- 67 grenzanhydrite
- 68 Zechstein shale
- 69 shaft
- 70 minehead buildings
- 71 storage chamber
- 72 storage of medium-active waste in salt mine
- 73 511 m level
- 74 protective screen (anti-radiation screen)
- 75 lead glass window
- 76 storage chamber
- 77 drum containing radioactive waste
- 78 television camera
- 79 charging chamber
- 80 control desk (control panel)
- 81 upward ventilator
- 82 shielded container
- 83 490 m level

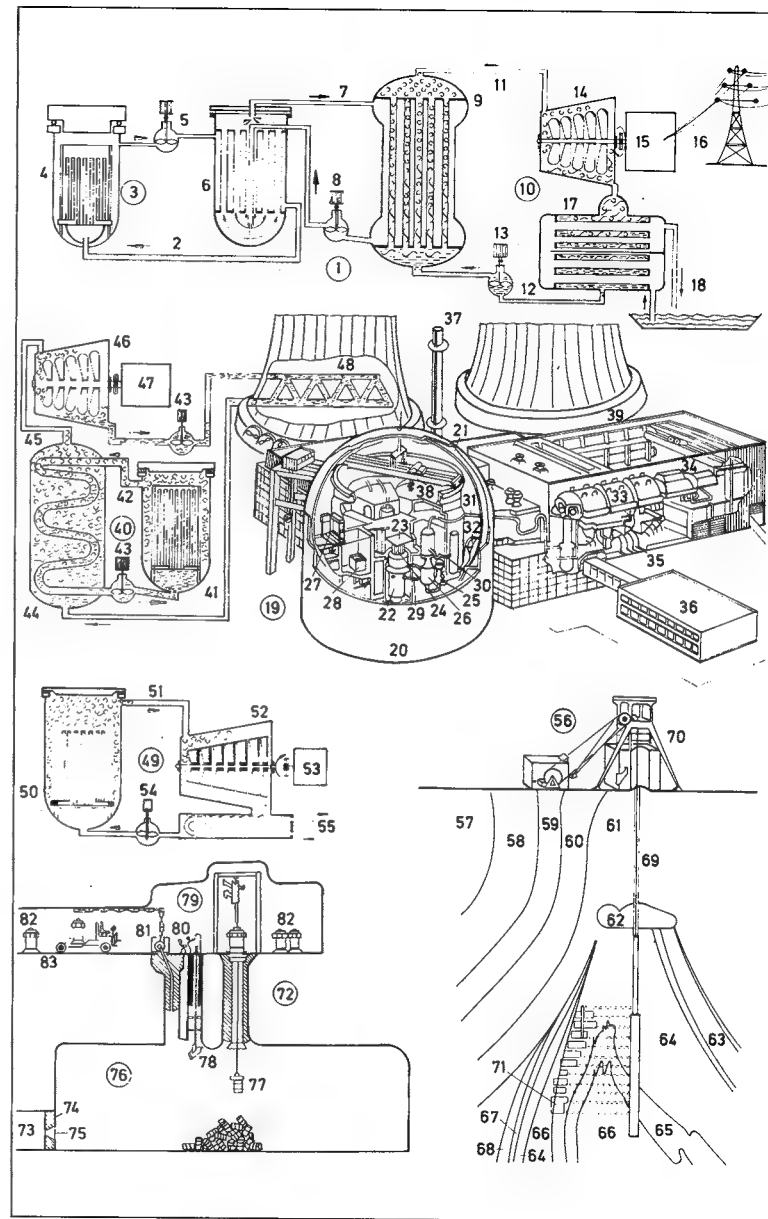

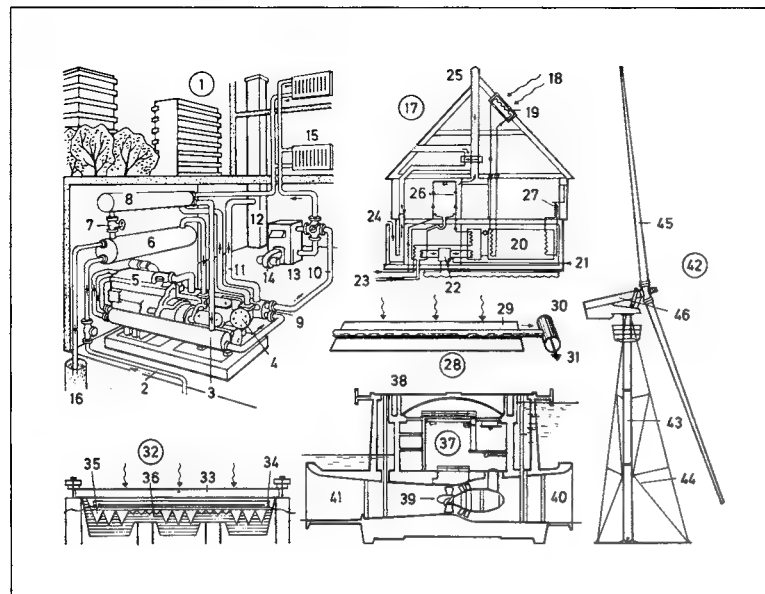

- | | |
|---|---|
| 1 heat pump system | 26 hot water supply |
| 2 source water inlet | 27 radiator heating |
| 3 cooling water heat exchanger | 28 flat plate solar collector |
| 4 compressor | 29 blackened receiver surface with asphalted aluminium (<i>Am.</i> aluminium) foil |
| 5 natural-gas or diesel engine | 30 steel tube |
| 6 evaporator | 31 heat transfer fluid |
| 7 pressure release valve | 32 flat plate solar collector, containing solar cell |
| 8 condenser | 33 glass cover |
| 9 waste-gas heat exchanger | 34 solar cell |
| 10 flow pipe | 35 air ducts |
| 11 vent pipe | 36 insulation |
| 12 chimney | 37 tidal power plant [section] |
| 13 boiler | 38 dam |
| 14 fan | 39 reversible turbine |
| 15 radiator | 40 turbine inlet for water from the sea |
| 16 sink | 41 turbine inlet for water from the basin |
| 17-36 utilization of solar energy | 42 wind power plant (wind generator aerogenerator) |
| 17 solar (solar-heated) house | 43 truss tower |
| 18 solar radiation (sunlight, insolation) collector | 44 guy wire |
| 19 radiator | 45 rotor |
| 20 hot reservoir (heat reservoir) | 46 generator with variable pitch for power regulation |
| 21 power supply | |
| 22 heat pump | |
| 23 water outlet | |
| 24 air supply | |
| 25 flue | |

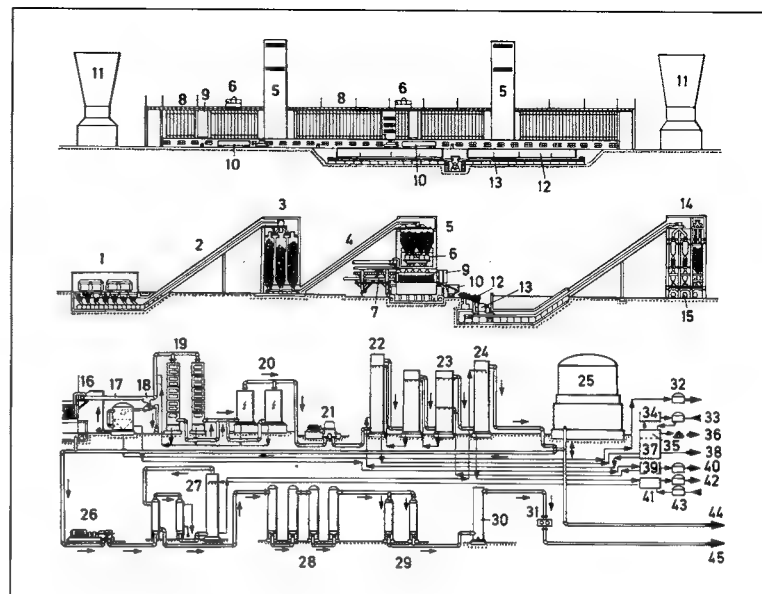

- | | |
|--|---|
| 1-15 coking plant | 24 benzene (benzol) scrubber |
| 1 dumping of coking coal | 25 gas holder |
| 2 belt conveyor | 26 gas compressor |
| 3 blending bunker | 27 debenzoling by cooler and heat exchanger |
| 4 service bunker conveyor | 28 desulphurization (<i>Am.</i> desulfurization) of pressure gas |
| 5 service bunker | 29 gas cooling |
| 6 larry car (larry, charging car) | 30 gas drying |
| 7 pusher ram | 31 gas meter |
| 8 battery of coke ovens | 32 crude tar tank |
| 9 coke guide | 33 sulphuric acid (<i>Am.</i> sulfuric acid) supply |
| 10 quenching car, with engine | 34 production of sulphuric acid (<i>Am.</i> sulfuric acid) |
| 11 quenching tower | 35 production of ammonium sulphate (<i>Am.</i> ammonium sulfate) |
| 12 coke loading bay (coke wharf) | 36 ammonium sulphate (<i>Am.</i> ammonium sulfate) |
| 13 coke wharf conveyor | 37 recovery plant for recovering the scrubbing agents |
| 14 screening of coke and breeze | 38 waste water discharge |
| 15 coke loading | 39 phenol extraction from the gas water |
| 16-45 coke-oven gas processing | 40 crude phenol tank |
| 16 discharge (release) of gas from the coke ovens | 41 production of crude benzol (crude benzene) |
| 17 gas-collecting main | 42 crude benzol (crude benzene) tank |
| 18 coal tar extraction | 43 scrubbing oil tank |
| 19 gas cooler | 44 low-pressure gas main |
| 20 electrostatic precipitator | 45 high-pressure gas main |
| 21 gas extractor | |
| 22 hydrogen sulphide (<i>Am.</i> hydrogen sulfide) scrubber (hydrogen sulphide wet collector) | |
| 23 ammonia scrubber (ammonia wet collector) | |

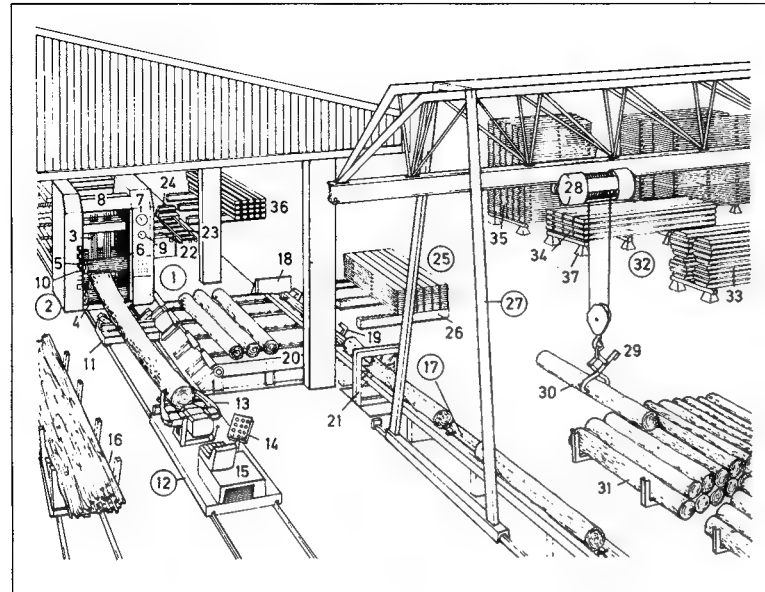

- | | |
|---|-----------------------------|
| 1 sawmill | 23 roller table |
| 2 vertical frame saw (<i>Am.</i> gang mill) | 24 undercut swing saw |
| 3 saw blades | 25 piling |
| 4 feed roller | 26 roller trestles |
| 5 guide roller | 27 gantry crane |
| 6 fluting (grooving, grooves) | 28 crane motor |
| 7 oil pressure gauge (<i>Am.</i> gage) | 29 pivoted log grips |
| 8 saw frame | 30 roundwood (round timber) |
| 9 feed indicator | 31 log dump |
| 10 log capacity scale | 32 squared timber store |
| 11 auxiliary carriage | 33 sawn logs |
| 12 carriage | 34 planks |
| 13 log grips | 35 boards (planks) |
| 14 remote control panel | 36 squared timber |
| 15 carriage motor | 37 stack bearer |
| 16 truck for splinters (splints) | |
| 17 endless log chain (<i>Am.</i> jack chain) | |
| 18 stop plate | |
| 19 log-kicker arms | |
| 20 cross conveyor | |
| 21 washer (washing machine) | |
| 22 cross chain conveyor for sawn timber | |

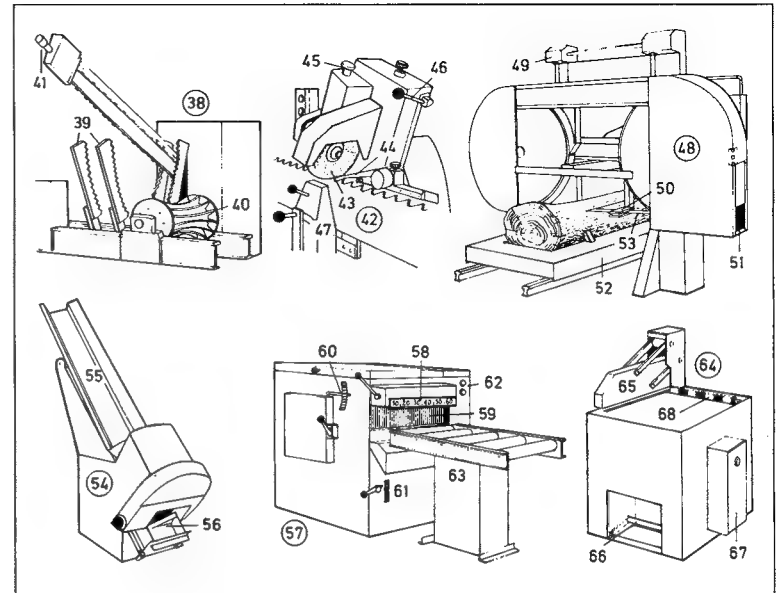

- | | |
|---|---|
| 38 automatic cross-cut chain saw | 60 height scale |
| 39 log grips | 61 in-feed scale |
| 40 feed roller | 62 indicator lamps |
| 41 chain-tensioning device | 63 feed table |
| 42 saw-sharpening machine | 64 undercut swing saw |
| 43 grinding wheel (teeth grinder) | 65 automatic hold-down with protective hood |
| 44 feed pawl | 66 foot switch |
| 45 depth adjustment for the teeth grinder | 67 distribution board (panelboard) |
| 46 lifter (lever) for the grinder chuck | 68 length stop |
| 47 holding device for the saw blade | |
| 48 horizontal bandsaw for sawing logs | |
| 49 height adjustment | |
| 50 chip remover | |
| 51 chip extractor | |
| 52 carriage | |
| 53 bandsaw blade | |
| 54 automatic blocking saw | |
| 55 feed channel | |
| 56 discharge opening | |
| 57 twin edger (double edger) | |
| 58 breadth scale (width scale) | |
| 59 kick-back guard (plates) | |

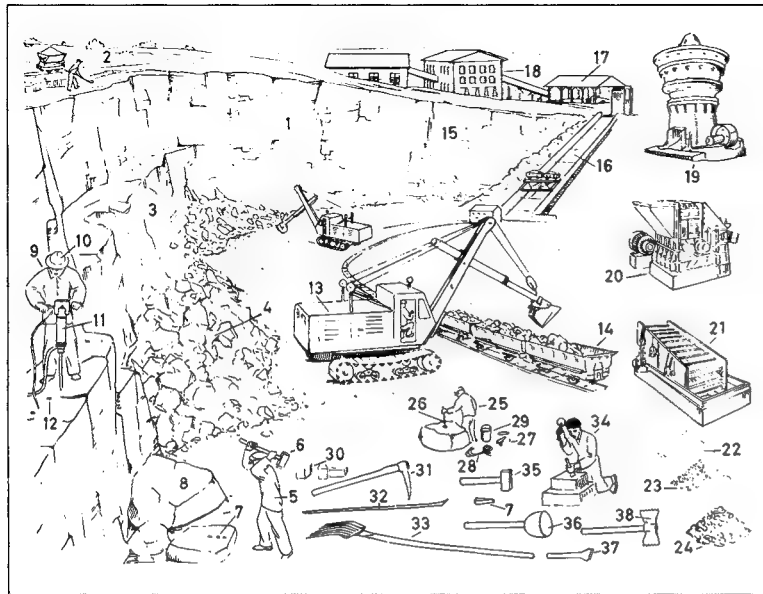

- | | |
|---|--|
| 1 quarry, an open-cast working | 22 screenings (fine dust) |
| 2 overburden | 23 stone chippings |
| 3 working face | 24 crushed stone |
| 4 loose rock pile (blasted rock) | 25 shot firer |
| 5 quarryman (quarrier), a quarry worker | 26 measuring rod |
| 6 sledge hammer | 27 blasting cartridge |
| 7 wedge | 28 fuse (blasting fuse) |
| 8 block of stone | 29 plugging sand (stemming sand) bucket |
| 9 driller | 30 dressed stone |
| 10 safety helmet | 31 pick |
| 11 hammer drill (hard-rock drill) | 32 crowbar (pinch bar) |
| 12 borehole | 33 fork |
| 13 universal excavator | 34 stonemason |
| 14 large-capacity truck | 35-38 stonemason's tools |
| 15 rock face | 35 stonemason's hammer |
| 16 inclined hoist | 36 mallet |
| 17 primary crusher | 37 drove chisel (drove, boaster, broad chisel) |
| 18 stone-crushing plant | 38 dressing axe (<i>Am. ax</i>) |
| 19 coarse rotary (gyratory) crusher; <i>sim.</i> : fine rotary (gyratory) crusher | |
| 20 hammer crusher (impact crusher) | |
| 21 vibrating screen | |

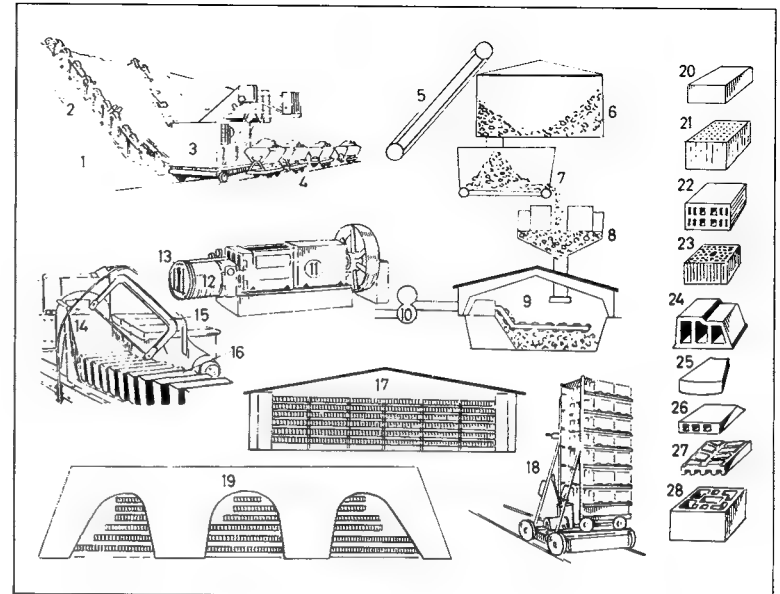

- | | |
|--|--|
| 1 clay pit | 19 circular kiln (brick kiln) |
| 2 loam, an impure clay (raw clay) | 20 solid brick (building brick) |
| 3 overburden excavator, a large-scale excavator | 21, 22 perforated bricks and hollow blocks |
| 4 narrow-gauge (<i>Am. narrow-gage</i>) track system | 23 hollow clay block with vertical perforations |
| 5 inclined hoist | 24 floor brick |
| 6 sourcing chambers | 25 compass brick (radial brick, radiating brick) |
| 7 box feeder (feeder) | 26 hollow flooring block |
| 8 edge runner mill (edge mill, pan grinding mill) | 27 paving brick |
| 9 rolling plant | 28 cellular brick [for fireplaces] (chimney brick) |
| 10 double-shaft trough mixer (mixer) | |
| 11 extrusion press (brick-pressing machine) | |
| 12 vacuum chamber | |
| 13 die | |
| 14 clay column | |
| 15 cutter (brick cutter) | |
| 16 unfired brick (green brick) | |
| 17 drying shed | |
| 18 mechanical finger car (stacker truck) | |

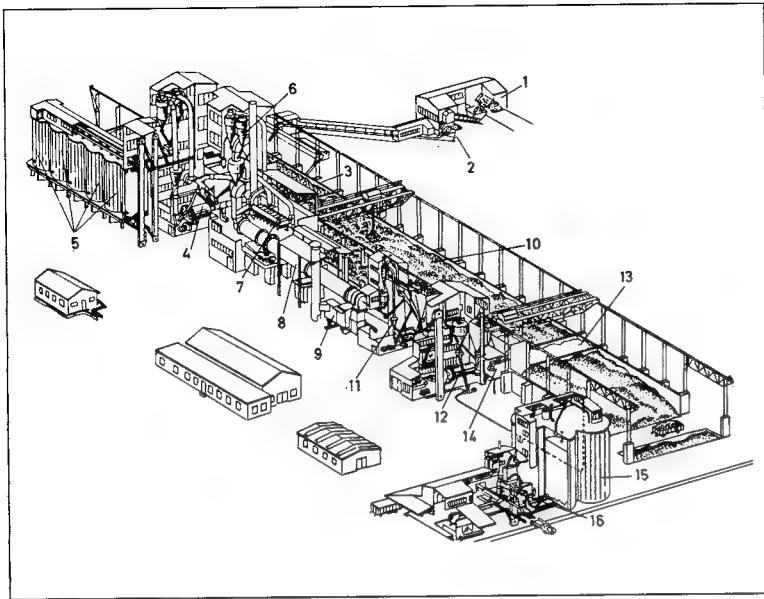

- 1 raw materials (limestone, clay and marl)
- 2 hammer crusher (hammer mill)
- 3 raw material store
- 4 raw mill for simultaneously grinding and drying the raw materials with exhaust gas from the heat exchanger
- 5 raw meal silos
- 6 heat exchanger (cyclone heat exchanger)
- 7 dust collector (an electrostatic precipitator) for the heat exchanger exhaust from the raw mill
- 8 rotary kiln
- 9 clinker cooler
- 10 clinker store
- 11 primary air blower
- 12 cement-grinding mill
- 13 gypsum store
- 14 gypsum crusher
- 15 cement silo
- 16 cement-packing plant

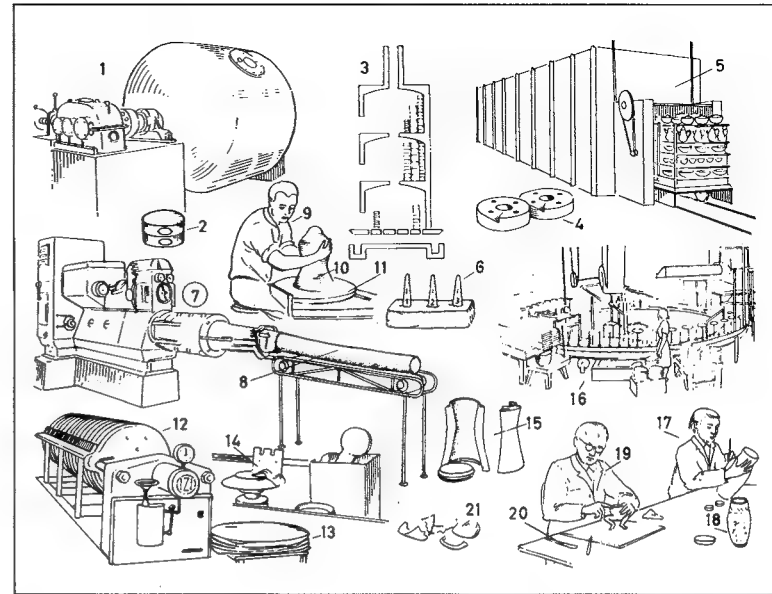

- 1 grinding cylinder (ball mill) for the preparation of the raw material in water
- 2 sample sagger (saggar, seggar), with aperture for observing the firing process
- 3 bottle kiln (beehive kiln) [diagram]
- 4 firing mould (*Am. mold*)
- 5 tunnel kiln
- 6 Seger cone (pyrometric cone, *Am. Orton cone*) for measuring high temperatures
- 7 de-airing pug mill (de-airing pug press), an extrusion press
- 8 clay column
- 9 thrower throwing a ball (bat) of clay
- 10 slug of clay
- 11 turntable; *sim.*: potter's wheel
- 12 filter press
- 13 filter cake
- 14 jiggering, with a profiling tool; *sim.*: jollyng
- 15 plaster mould (*Am. mold*) for slip casting
- 16 turntable glazing machine
- 17 porcelain painter (*china painter*)
- 18 hand-painted vase
- 19 repairer
- 20 pallet (modelling, *Am. modeling, tool*)
- 21 shards (*sherds, potsherds*)

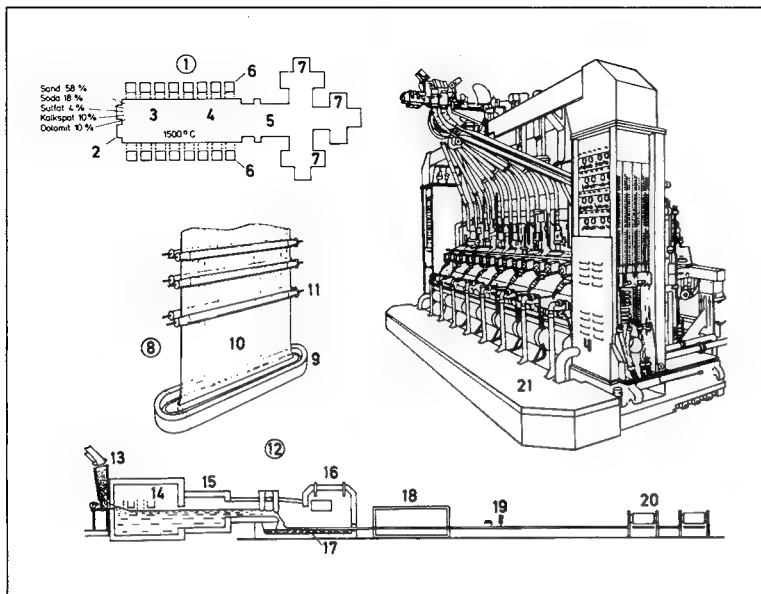

1-20 sheet glass production (flat glass production)

- 1 glass furnace (tank furnace) for the Fourcault process [diagram]
- 2 filling end, for feeding in the batch (frit)
- 3 melting bath
- 4 refining bath (fining bath)
- 5 working baths (working area)
- 6 burners
- 7 drawing machines
- 8 Fourcault glass-drawing machine
- 9 slot
- 10 glass ribbon (ribbon of glass, sheet of glass) being drawn upwards
- 11 rollers (drawing rolls)
- 12 float glass process
- 13 batch (frit) feeder (funnel)
- 14 melting bath
- 15 cooling tank
- 16 float bath in a protective inert-gas atmosphere

- 17 molten tin
- 18 annealing lehr
- 19 automatic cutter
- 20 stacking machines
- 21 IS (individual-section) machine, a bottle-making machine
- 22-37 blowing processes**
- 22 blow-and-blow process
- 23 introduction of the gob of molten glass
- 24 first blowing
- 25 suction
- 26 transfer from the parison mould (Am. mold) to the blow mould (Am. mold)
- 27 reheating
- 28 blowing (suction, final shaping)
- 29 delivery of the completed vessel
- 30 press-and-blow process
- 31 introduction of the gob of molten glass
- 32 plunger

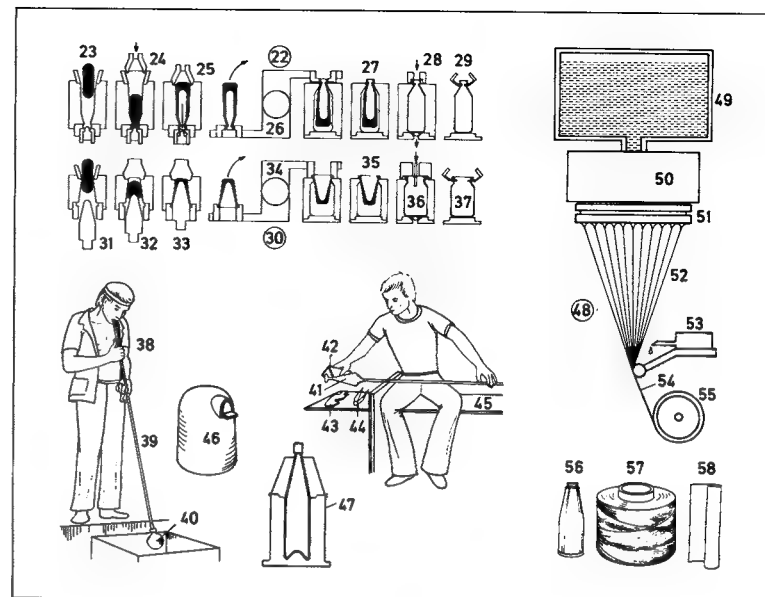

- 33 pressing
- 34 transfer from the press mould (Am. mold) to the blow mould (Am. mold)
- 35 reheating
- 36 blowing (suction, final shaping)
- 37 delivery of the completed vessel
- 38-47 glassmaking (glassblowing, glassblowing by hand, glass forming)**
- 38 glassmaker (glassblower)
- 39 blowing iron
- 40 gob
- 41 hand-blown goblet
- 42 clappers for shaping the base (foot) of the goblet
- 43 trimming tool
- 44 tongs
- 45 glassmaker's chair (gaffer's chair)
- 46 covered glasshouse pot
- 47 mould (Am. mold), into which the parison is blown

- 48-55 production of glass fibre (Am. glass fiber)**
- 48 continuous filament process
- 49 glass furnace
- 50 bushing containing molten glass
- 51 bushing tips
- 52 glass filaments
- 53 sizing
- 54 strand (thread)
- 55 spool
- 56-58 glass fibre (Am. glass fiber) products**
- 56 glass yarn (glass thread)
- 57 sleeved glass yarn (glass thread)
- 58 glass wool

1-13 supply of cotton

- 1 ripe cotton boll
- 2 full cop (cop wound with weft yarn)
- 3 compressed cotton bale
- 4 jute wrapping
- 5 steel band
- 6 identification mark of the bale
- 7 bale opener (bale breaker)
- 8 cotton-feeding brattice
- 9 cotton feed
- 10 dust extraction fan
- 11 duct to the dust-collecting chamber
- 12 drive motor
- 13 conveyor brattice
- 14 **double scutcher** (machine with two scutchers)
- 15 lap cradle
- 16 rack head
- 17 starting handle
- 18 handwheel, for raising and lowering the rack head
- 19 movable lap-turner
- 20 calender rollers
- 21 cover for the perforated cylinders
- 22 dust escape flue (dust discharge flue)
- 23 drive motors (beater drive motors)
- 24 beater driving shaft
- 25 three-blade beater (Kirschner beater)
- 26 grid [for impurities to drop]
- 27 pedal roller (pedal cylinder)
- 28 control lever for the pedal roller, a pedal lever
- 29 variable change-speed gear
- 30 cone drum box
- 31 stop and start levers for the hopper
- 32 wooden hopper delivery roller
- 33 hopper feeder
- 34 **carding machine** (card, carding engine)
- 35 card can (carding can), for receiving the coiled sliver
- 36 can holder
- 37 calender rollers
- 38 carded sliver (card sliver)

- 39 vibrating doffer comb
- 40 start-stop lever
- 41 grinding-roller bearing
- 42 doffer
- 43 cylinder
- 44 flat clearer
- 45 flats
- 46 supporting pulleys for the flats
- 47 scutcher lap (carded lap)
- 48 scutcher lap holder
- 49 drive motor with flat belt
- 50 main drive pulley (fast-and-loose drive pulley)
- 51 principle of the card (of the carding engine)
- 52 fluted feed roller
- 53 licker-in (taker-in, licker-in roller)
- 54 licker-in undercasing
- 55 cylinder undercasing
- 56 **combing machine** (comber)
- 57 drive gearbox (driving gear)
- 58 laps ready for combing
- 59 calender rollers
- 60 comber draw box
- 61 counter
- 62 coiler top
- 63 principle of the comber
- 64 lap
- 65 bottom nipper
- 66 top nipper
- 67 top comb
- 68 combing cylinder
- 69 plain part of the cylinder
- 70 needled part of the cylinder
- 71 detaching rollers
- 72 carded and combed sliver

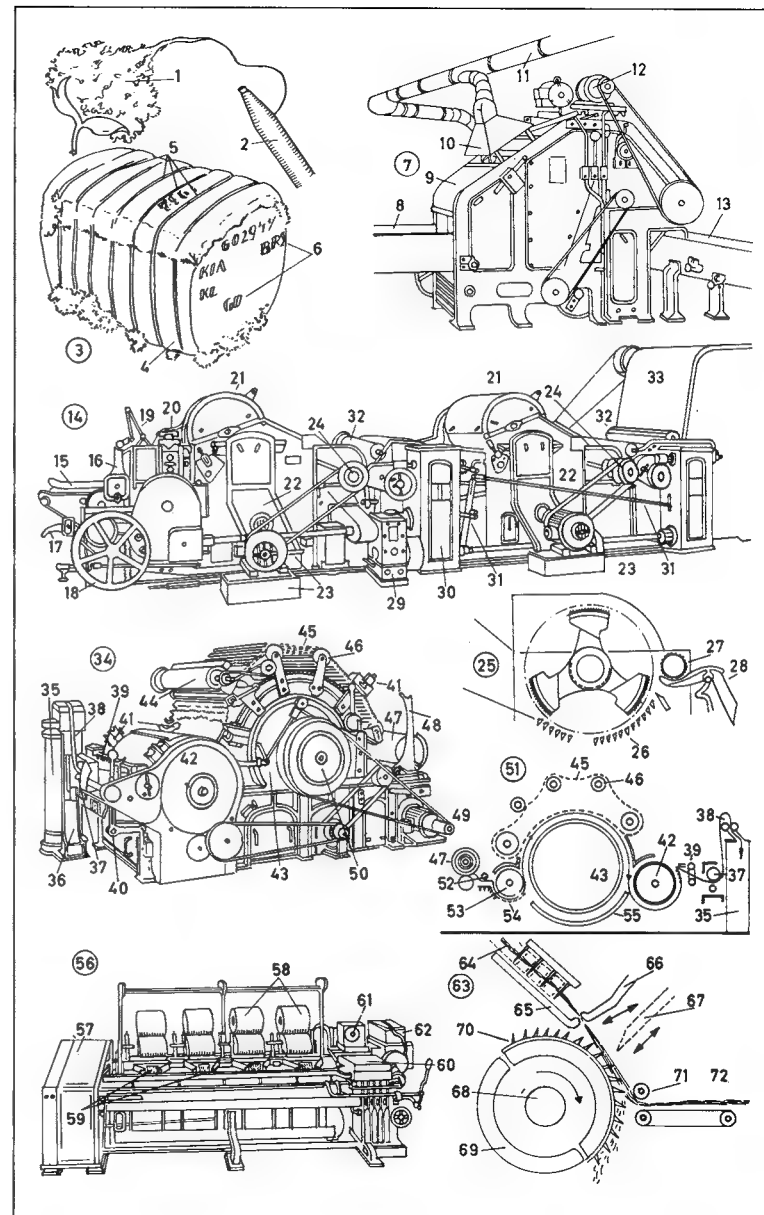

- 1 draw frame
- 2 gearbox with built-in motor
- 3 sliver cans
- 4 broken thread detector roller
- 5 doubling of the slivers
- 6 stopping handle
- 7 draw frame cover
- 8 indicator lamps (signal lights)
- 9 simple four-roller draw frame [diagram]
- 10 bottom rollers (lower rollers), fluted steel rollers
- 11 top rollers (upper rollers) covered with synthetic rubber
- 12 doubled slivers before drafting
- 13 thin sliver after drafting
- 14 high-draft system (high-draft draw frame) [diagram]
- 15 feeding-in of the sliver
- 16 leather apron (composition apron)
- 17 guide bar
- 18 light top roller (guide roller)
- 19 high-draft speed frame (fly frame, slubbing frame)
- 20 sliver cans
- 21 feeding of the slivers to the drafting rollers
- 22 drafting rollers with top clearers
- 23 roving bobbins
- 24 fly frame operator (operative)
- 25 flyer
- 26 frame end plate
- 27 intermediate yarn-forming frame
- 28 bobbin creel (creel)
- 29 roving emerging from the drafting rollers
- 30 lifter rail (separating rail)
- 31 spindle drive
- 32 stopping handle
- 33 gearbox, with built-on motor
- 34 ring frame (ring spinning frame)
- 35 three-phase motor
- 36 motor base plate (bedplate)
- 37 lifting bolt [for motor removal]
- 38 control gear for spindle speed
- 39 gearbox

- 40 change wheels for varying the spindle speed [to change the yarn count]
- 41 full creel
- 42 shafts and levers for raising and lowering the ring rail
- 43 spindles with separators
- 44 suction box connected to the front roller underclearers
- 45 standard ring spindle
- 46 spindle shaft
- 47 roller bearing
- 48 wharve (pulley)
- 49 spindle catch
- 50 spindle rail
- 51 ring and traveller (*Am. traveler*)
- 52 top of the ring tube (of the bobbin)
- 53 yarn (thread)
- 54 ring fitted into the ring rail
- 55 traveller (*Am. traveler*)
- 56 yarn wound onto the bobbin
- 57 doubling frame
- 58 creel, with cross-wound cheeses
- 59 delivery rollers
- 60 bobbins of doubled yarn

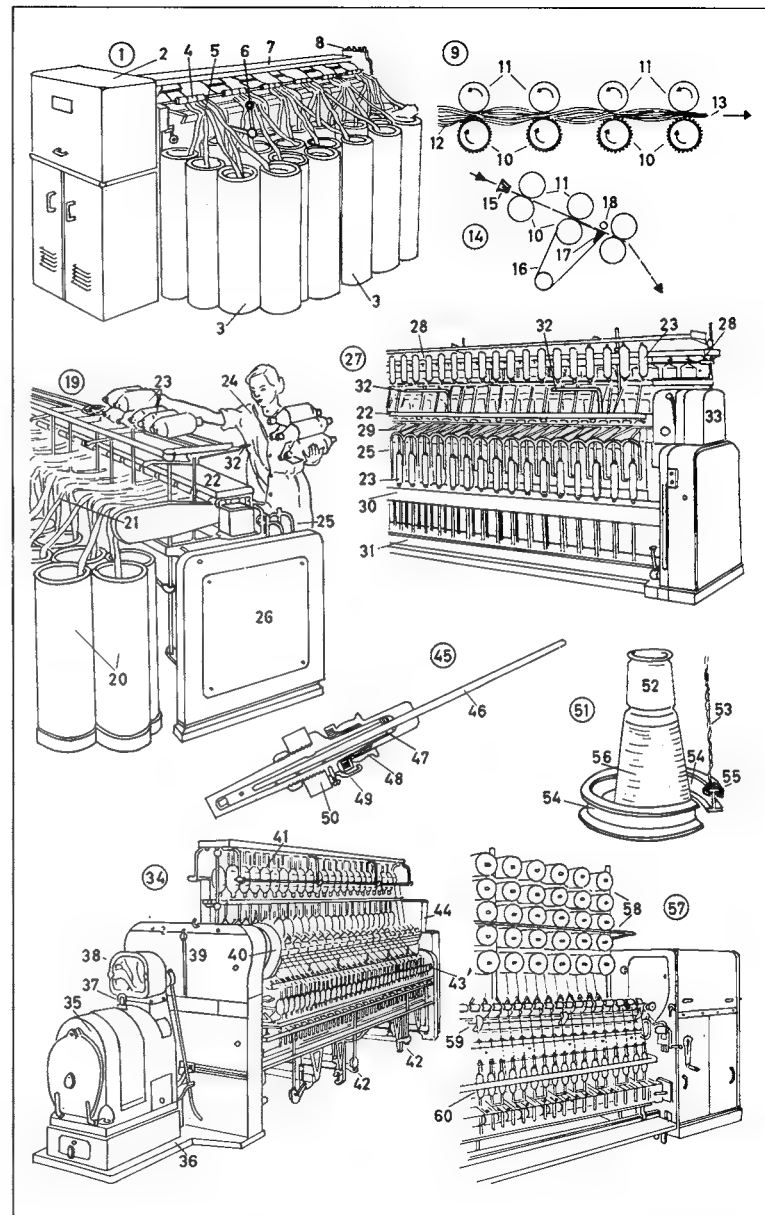

1-57 processes preparatory to weaving

- 1 cone-winding frame
- 2 travelling (*Am.* traveling) blower
- 3 guide rail, for the travelling (*Am.* traveling) blower
- 4 blowing assembly
- 5 blower aperture
- 6 superstructure for the blower rail
- 7 full-cone indicator
- 8 cross-wound cone
- 9 cone creel
- 10 grooved cylinder
- 11 guiding slot for cross-winding the threads
- 12 side frame, housing the motor
- 13 tension and slub-catching device
- 14 off-end framing with filter
- 15 yarn package, a ring tube or mule cop
- 16 yarn package container
- 17 starting and stopping lever
- 18 self-threading guide
- 19 broken thread stop motion
- 20 thread clearer
- 21 weighting disc (disk) for tensioning the thread
- 22 warping machine
- 23 fan
- 24 cross-wound cone
- 25 creel
- 26 adjustable comb
- 27 warping machine frame
- 28 yarn length recorder
- 29 warp beam
- 30 beam flange
- 31 guard rail
- 32 driving drum (driving cylinder)
- 33 belt drive
- 34 motor
- 35 release for starting the driving drum
- 36 screw for adjusting the comb setting
- 37 drop pins, for stopping the machine when a thread breaks
- 38 guide bar
- 39 drop pin rollers

- 40 indigo dyeing and sizing machine
- 41 take-off stand
- 42 warp beam
- 43 warp
- 44 wetting trough
- 45 immersion roller
- 46 squeeze roller (mangle)
- 47 dye liquor padding trough
- 48 air oxidation passage
- 49 washing trough
- 50 drying cylinders for pre-drying
- 51 tension compensator (tension equalizer)
- 52 sizing machine
- 53 drying cylinders
- 54 *for cotton: stenter; for wool: tenter*
- 55 beaming machine
- 56 sized warp beam
- 57 rollers

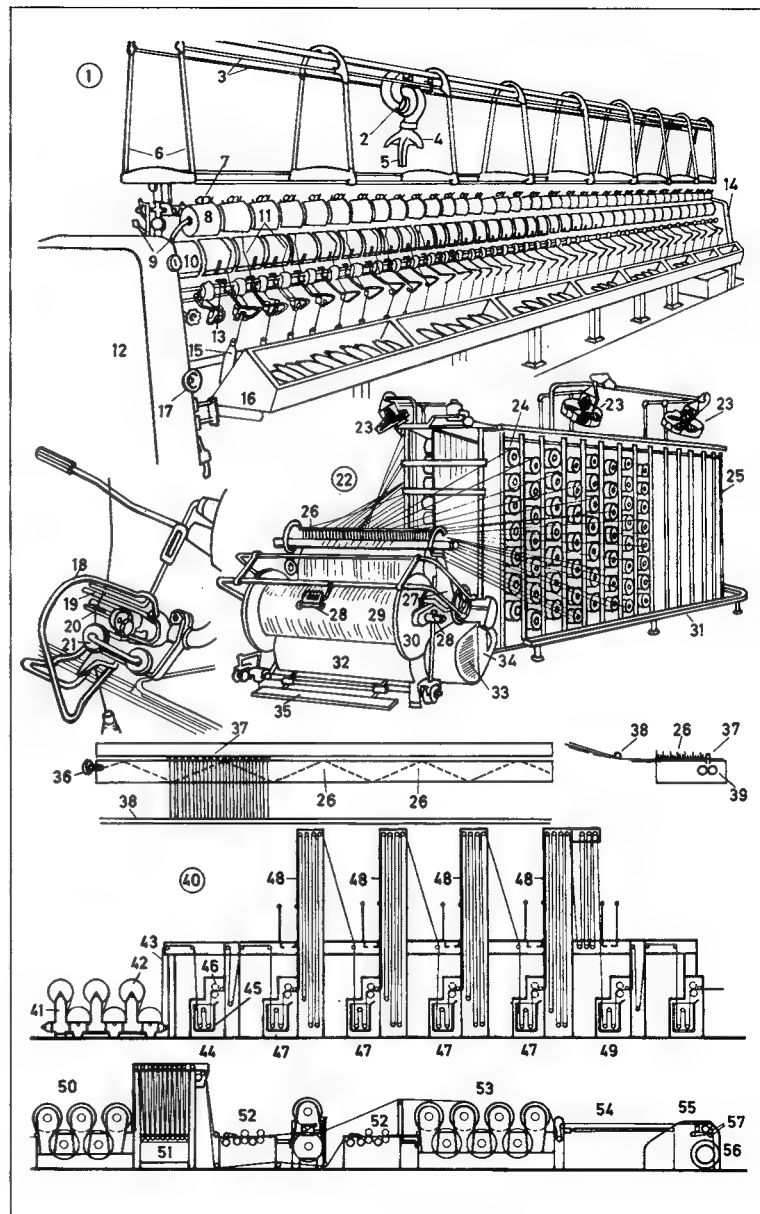

- 1 weaving machine (automatic loom)
- 2 pick counter (tachometer)
- 3 shaft (heald shaft, heald frame)
- 4 shafts (heald shafts, heald frames)
- 5 rotary battery for weft replenishment
- 6 sley (sley) cap
- 7 weft pin
- 8 starting and stopping handle
- 9 shuttle box, with shuttles
- 10 reed
- 11 selvage (selvage)
- 12 cloth (woven fabric)
- 13 temple (cloth temple)
- 14 electric weft feeler
- 15 flywheel
- 16 breast beam board
- 17 picking stick (pick stick)
- 18 electric motor
- 19 cloth take-up motion
- 20 cloth roller (fabric roller)
- 21 can for empty pirns
- 22 lug strap, for moving the picking stick
- 23 fuse box
- 24 loom framing
- 25 metal shuttle tip
- 26 shuttle
- 27 heald (heddle, wire heald, wire heddle)
- 28 eye (eyelet, heald eyelet, heddle eyelet)
- 29 eye (shuttle eye)
- 30 pirn
- 31 metal contact sleeve for the weft feeler
- 32 slot for the feeler
- 33 spring-clip pirn holder
- 34 drop wire
- 35 weaving machine (automatic loom) [side elevation]
- 36 heald shaft guiding wheels
- 37 backrest
- 38 lease rods
- 39 warp (warp thread)
- 40 shed

- 41 sley (sley)
- 42 race board
- 43 stop rod blade for the stop motion
- 44 bumper steel
- 45 bumper steel stop rod
- 46 breast beam
- 47 cloth take-up roller
- 48 warp beam
- 49 beam flange
- 50 crankshaft
- 51 crankshaft wheel
- 52 connector
- 53 sley (sley)
- 54 lam rods
- 55 camshaft wheel
- 56 camshaft (tappet shaft)
- 57 tappet (shedding tappet)
- 58 treadle lever
- 59 let-off motion
- 60 beam motion control
- 61 rope of the warp let-off motion
- 62 let-off weight lever
- 63 control weight [for the treadle]
- 64 picker with leather or bakelite pad
- 65 picking stick buffer
- 66 picking cam
- 67 picking bowl
- 68 picking stick return spring

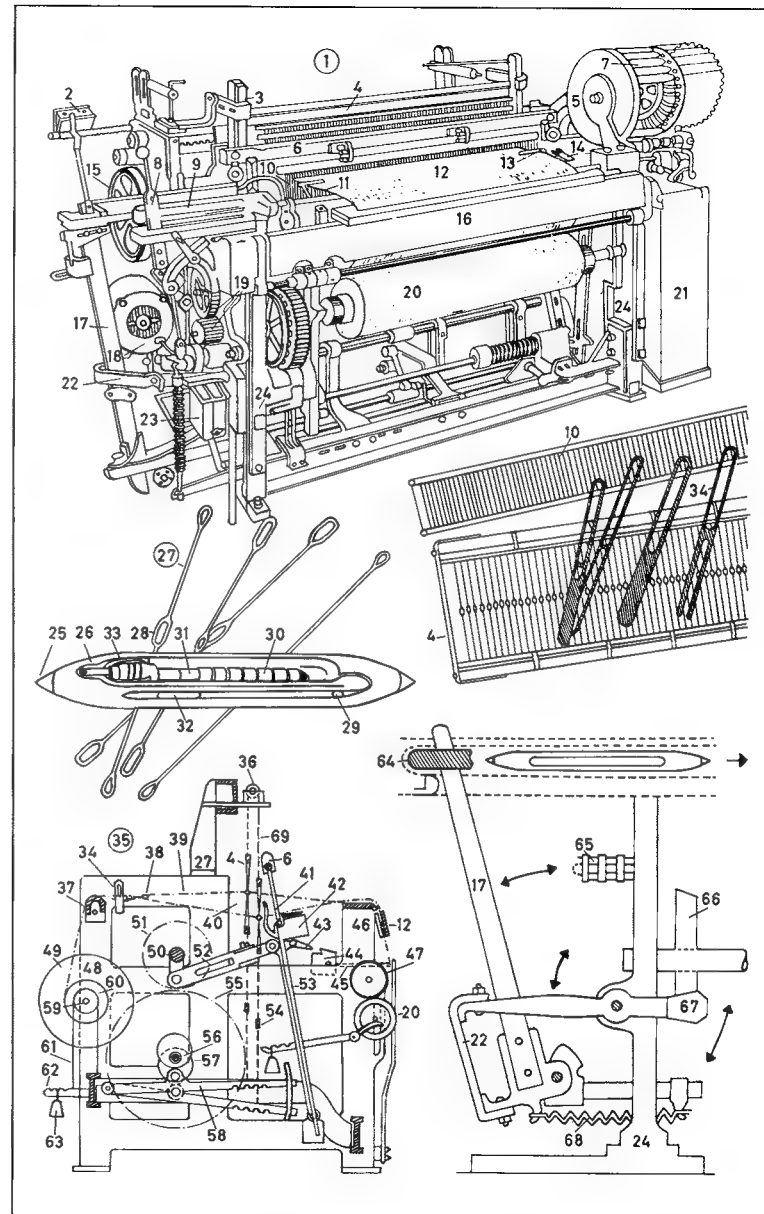

1-66 hosiery mill

- 1 circular knitting machine for the manufacture of tubular fabric
- 2 yarn guide support post (thread guide support post)
- 3 yarn guide (thread guide)
- 4 bottle bobbin
- 5 yarn-tensioning device
- 6 yarn feeder
- 7 handwheel for rotating the machine by hand
- 8 needle cylinder (cylindrical needle holder)
- 9 tubular fabric
- 10 fabric drum (fabric box, fabric container)
- 11 needle cylinder (cylindrical needle holder) [section]
- 12 latch needles arranged in a circle
- 13 cam housing
- 14 needle cams
- 15 needle trick
- 16 cylinder diameter (*also*: diameter of tubular fabric)
- 17 thread (yarn)
- 18 Cotton's patent flat knitting machine for ladies' fully-fashioned hose
- 19 pattern control chain
- 20 side frame
- 21 knitting head
- 22 starting rod
- 23 Raschel warp-knitting machine
- 24 warp (warp beam)
- 25 yarn-distributing (yarn-dividing) beam
- 26 beam flange
- 27 row of needles
- 28 needle bar
- 29 fabric (Raschel fabric) [curtain lace and net fabrics] on the fabric roll
- 30 handwheel
- 31 motor drive gear
- 32 take-down weight
- 33 frame
- 34 base plate

- 35 hand flat (flat-bed) knitting machine
- 36 thread (yarn)
- 37 return spring
- 38 support for springs
- 39 carriage
- 40 feeder-selecting device
- 41 carriage handles
- 42 scale for regulating size of stitches
- 43 course counter (tachometer)
- 44 machine control lever
- 45 carriage rail
- 46 back row of needles
- 47 front row of needles
- 48 knitted fabric
- 49 tension bar
- 50 tension weight
- 51 needle bed showing knitting action
- 52 teeth of knock-over bit
- 53 needles in parallel rows
- 54 yarn guide (thread guide)
- 55 needle bed
- 56 retaining plate for latch needles
- 57 guard cam
- 58 sinker
- 59 needle-raising cam
- 60 needle butt
- 61 latch needle
- 62 loop
- 63 pushing the needle through the fabric
- 64 yarn guide (thread guide) placing yarn in the needle hook
- 65 loop formation
- 66 casting off of loop

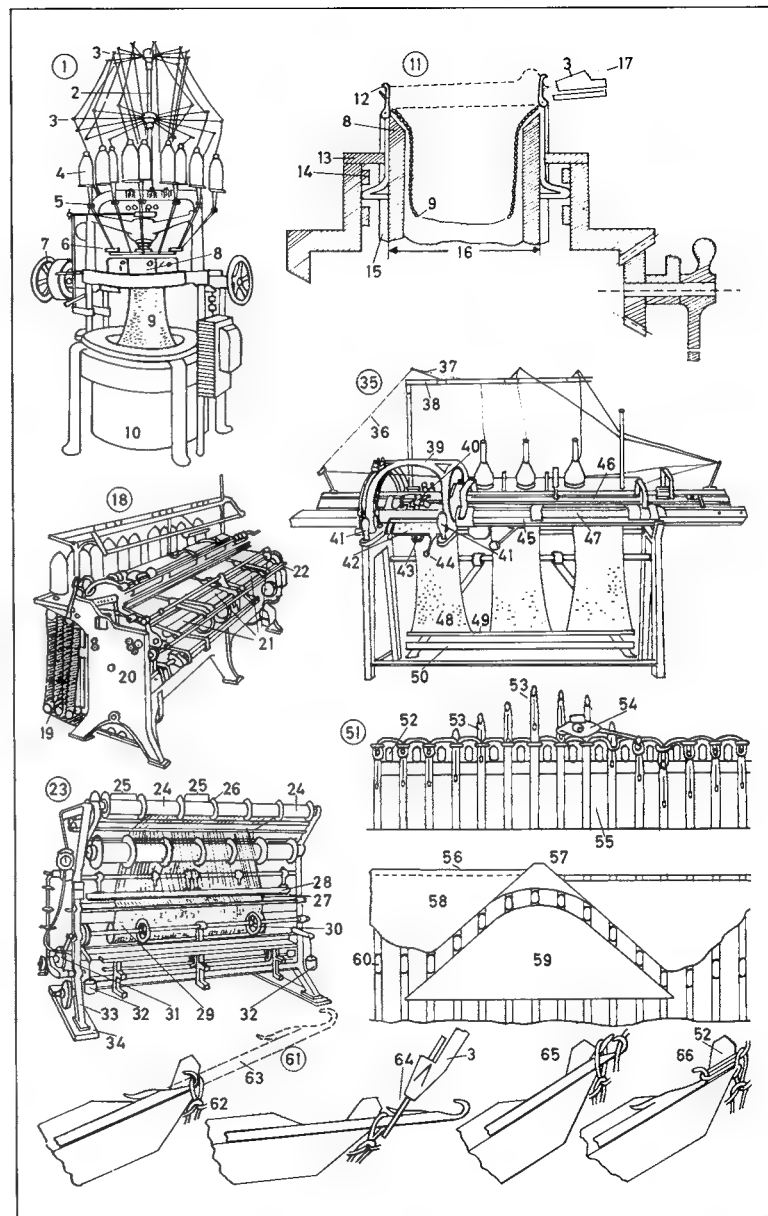

1-65 finishing

- 1 rotary milling (fulling) machine for felting the woollen (*Am.* woollen) fabric
- 2 pressure weights
- 3 top milling roller (top fulling roller)
- 4 drive wheel of bottom milling roller (bottom fulling roller)
- 5 fabric guide roller
- 6 bottom milling roller (bottom fulling roller)
- 7 draft board
- 8 open-width scouring machine for finer fabrics
- 9 fabric being drawn off the machine
- 10 drive gearbox
- 11 water inlet pipe
- 12 drawing-in roller
- 13 scroll-opening roller
- 14 pendulum-type hydro-extractor (centrifuge), for extracting liquors from the fabric
- 15 machine base
- 16 casing over suspension
- 17 outer casing containing rotating cage (rotating basket)
- 18 hydro-extractor (centrifuge) lid
- 19 stop-motion device (stopping device)
- 20 automatic starting and braking device
- 21 *for cotton:* stenter; *for wool:* tenter
- 22 air-dry fabric
- 23 operator's (operative's) platform
- 24 feeding of fabric by guides onto stenter (tenter) pins or clips
- 25 electric control panel
- 26 initial overfeed to produce shrink-resistant fabric when dried
- 27 thermometer
- 28 drying section
- 29 air outlet
- 30 plaiter (fabric-plaiting device)
- 31 wire-roller fabric-raising machine for producing raised or nap surface
- 32 drive gearbox

- 33 unraised cloth
- 34 wire-covered rollers
- 35 plaiter (cuttling device)
- 36 raised fabric
- 37 plaiting-down platform
- 38 rotary press (calendering machine), for press finishing
- 39 fabric
- 40 control buttons and control wheels
- 41 heated press bowl
- 42 rotary cloth-shearing machine
- 43 suction slot, for removing loose fibres (*Am.* fibers)
- 44 doctor blade (cutting cylinder)
- 45 protective guard
- 46 rotating brush
- 47 curved scray entry
- 48 treadle control
- 49 [non-shrinking] decatizing (decatizing) fabric-finishing machine
- 50 perforated decatizing (decatizing) cylinder
- 51 piece of fabric
- 52 cranked control handle
- 53 ten-colour (*Am.* ten-color) roller printing machine
- 54 base of the machine
- 55 drive motor
- 56 blanket [of rubber or felt]
- 57 fabric after printing (printed fabric)
- 58 electric control panel (control unit)
- 59 screen printing
- 60 mobile screen frame
- 61 squeegee
- 62 pattern stencil
- 63 screen table
- 64 fabric gummed down on table ready for printing
- 65 screen printing operator (operative)

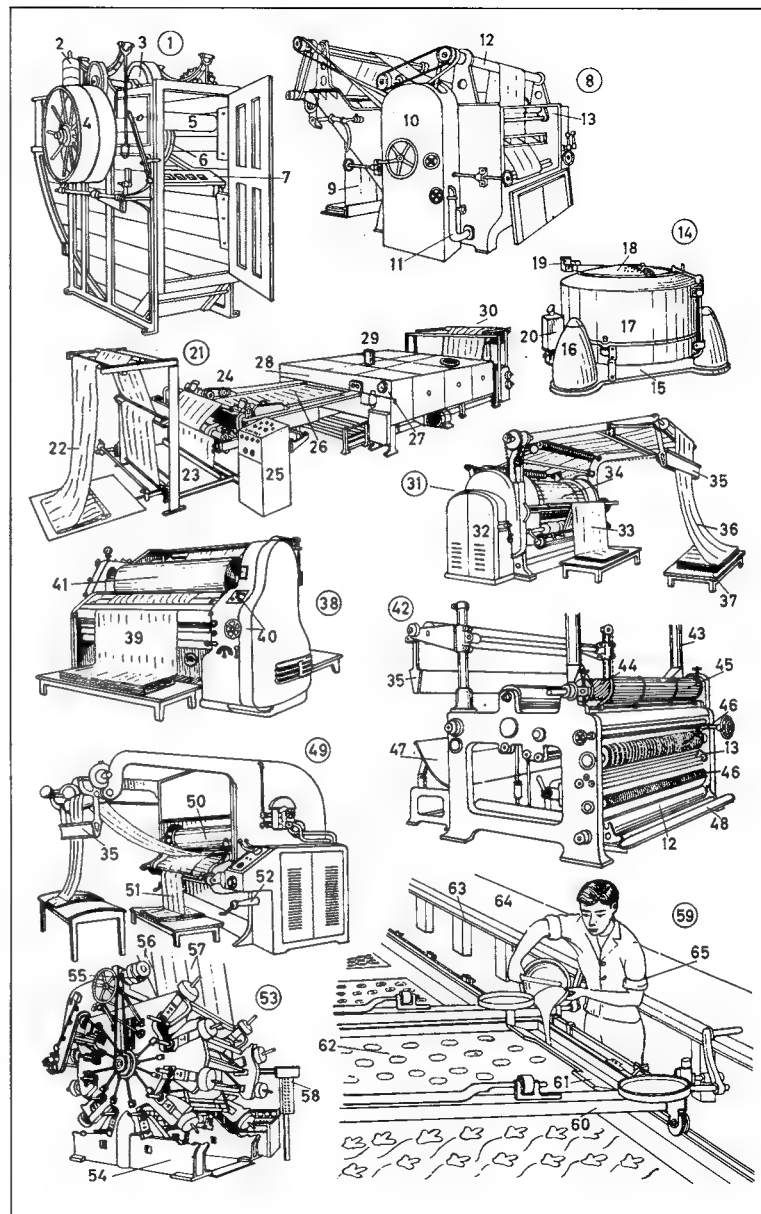

169 Synthetic (Man-made) Fibres (Am. Fibers) I

1-34 manufacture of **continuous filament and staple fibre** (Am. fiber) **viscose rayon yarns** by means of the viscose process

1-12 from raw material to viscose rayon

1 basic material [beech and spruce cellulose in form of sheets]

2 mixing cellulose sheets

3 caustic soda

4 steeping cellulose sheets in caustic soda

5 pressing out excess caustic soda

6 shredding the cellulose sheets

7 maturing (controlled oxidation) of the alkali-cellulose crumbs

8 carbon disulphide (Am. carbon disulfide)

9 conversion of alkali-cellulose into cellulose xanthate

10 dissolving the xanthate in caustic soda for the preparation of the viscose spinning solution

11 vacuum ripening tanks

12 filter presses

13-27 from viscose to viscose rayon thread

13 metering pump

14 multi-holed spinneret (spinning jet)

15 coagulating (spinning) bath for converting (coagulating) viscose (viscous solution) into solid filaments

16 Godet wheel, a glass pulley

17 Topham centrifugal pot (box) for twisting the filaments into yarn

18 viscose rayon cake

19-27 processing of the cake

19 washing

20 desulphurizing (desulphurization, Am. desulfurizing, desulfurization)

21 bleaching

22 treating of cake to give filaments softness and suppleness

23 hydro-extraction to remove surplus moisture

24 drying in heated room

25 winding yarn from cake into cone form

26 cone-winding machine

27 viscose rayon yarn on cone ready for use

28-34 from viscose spinning solution to viscose rayon staple fibre (Am. fiber)

28 filament tow

29 overhead spray washing plant

30 cutting machine for cutting filament tow to desired length

31 multiple drying machine for cut-up staple fibre (Am. fiber) layer (lap)

32 conveyor belt (conveyor)

33 baling press

34 bale of viscose rayon ready for dispatch (despatch)

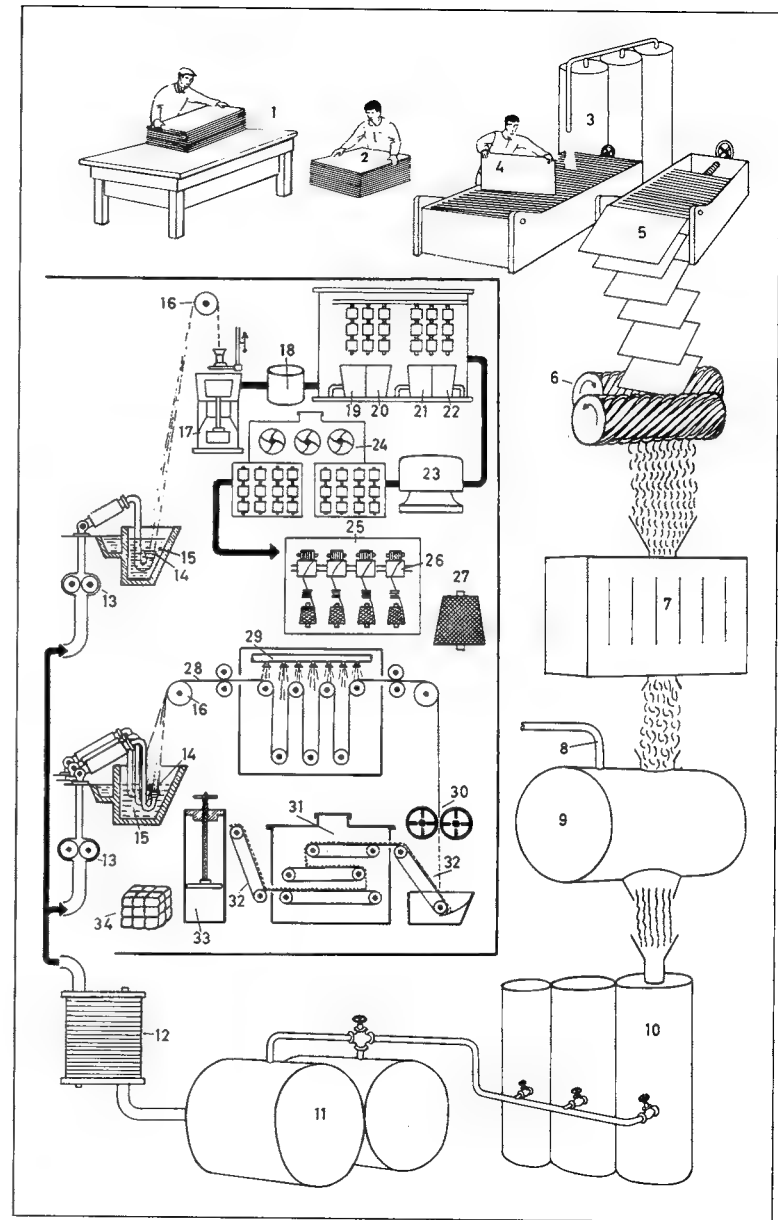

1-62 manufacture of polyamide

(nylon 6, perlon) fibres (Am. fibers)

- 1 coal [raw material for manufacture of polyamide (nylon 6, perlon) fibres (Am. fibers)]
- 2 coking plant for dry coal distillation
- 3 extraction of coal tar and phenol
- 4 gradual distillation of tar
- 5 condenser
- 6 benzene extraction and dispatch (despatch)
- 7 chlorine
- 8 benzene chlorination
- 9 monochlorobenzene (chlorobenzene)
- 10 caustic soda solution
- 11 evaporation of chlorobenzene and caustic soda
- 12 autoclave
- 13 sodium chloride (common salt), a by-product
- 14 phenol (carbolic acid)
- 15 hydrogen inlet
- 16 hydrogenation of phenol to produce raw cyclohexanol
- 17 distillation
- 18 pure cyclohexanol
- 19 oxidation (dehydrogenation)
- 20 formation of cyclohexanone (pimehinketone)
- 21 hydroxylamine inlet
- 22 formation of cyclohexanoxime
- 23 addition of sulphuric acid (Am. sulfuric acid) to effect molecular rearrangement
- 24 ammonia to neutralize sulphuric acid (Am. sulfuric acid)
- 25 formation of caprolactam oil
- 26 ammonium sulphate (Am. ammonium sulfate) solution
- 27 cooling cylinder
- 28 caprolactam
- 29 weighing apparatus
- 30 melting pot
- 31 pump
- 32 filter
- 33 polymerization in the autoclave
- 34 cooling of the polyamide
- 35 solidification of the polyamide
- 36 vertical lift (Am. elevator)
- 37 extractor for separating the polyamide from the remaining lactam oil
- 38 drier
- 39 dry polyamide chips
- 40 chip container
- 41 top of spinneret for melting the polyamide and forcing it through spinneret holes (spinning jets)
- 42 spinneret holes (spinning jets)
- 43 solidification of polyamide filaments in the cooling tower
- 44 collection of extruded filaments into thread form
- 45 preliminary stretching (preliminary drawing)
- 46 stretching (cold-drawing) of the polyamide thread to achieve high tensile strength
- 47 final stretching (final drawing)
- 48 washing of yarn packages
- 49 drying chamber
- 50 rewinding
- 51 polyamide cone
- 52 polyamide cone ready for dispatch (despatch)
- 53 mixer
- 54 polymerization under vacua
- 55 stretching (drawing)
- 56 washing
- 57 finishing of tow for spinning
- 58 drying of tow
- 59 crimping of tow
- 60 cutting of tow into normal staple lengths
- 61 polyamide staple
- 62 bale of polyamide staple

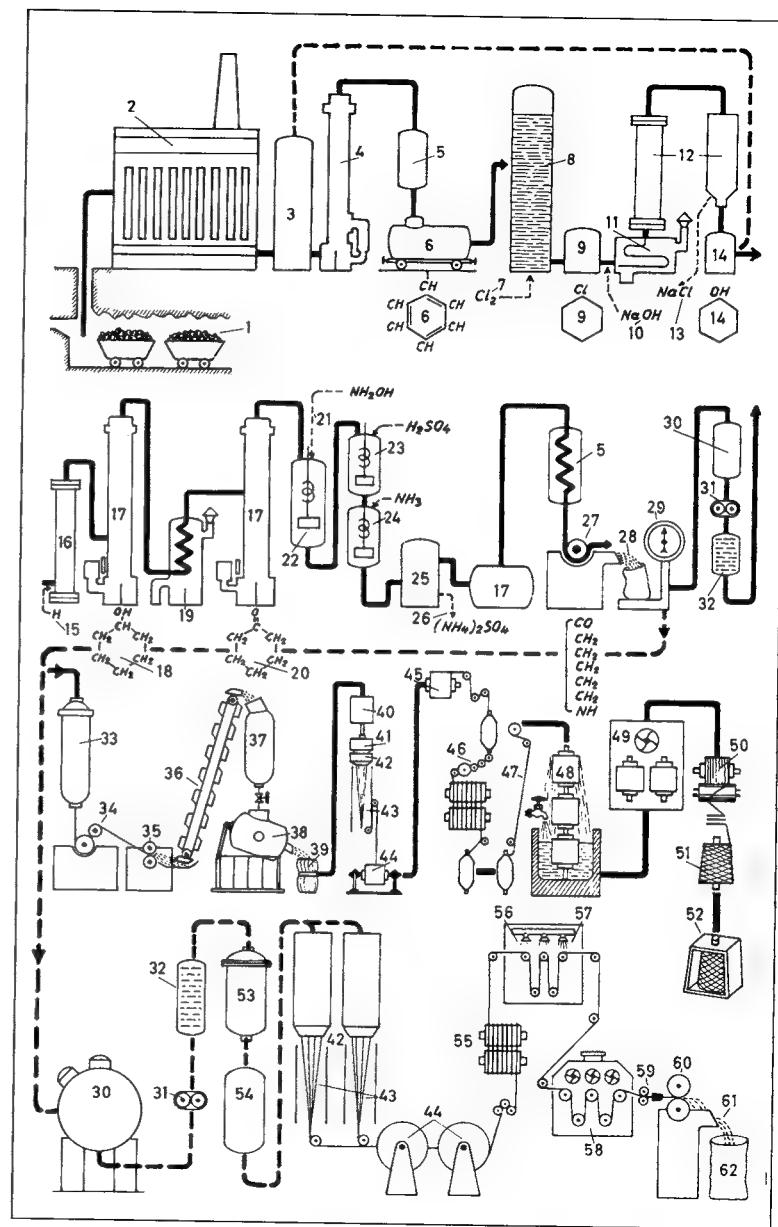

1-29 weaves [black squares: warp thread raised, weft thread lowered; white squares: weft thread raised, warp thread lowered]

- 1 plain weave (tabby weave) [weave viewed from above]
- 2 warp thread
- 3 weft thread
- 4 draft (point paper design) for plain weave
- 5 threading draft
- 6 denting draft (reed-threading draft)
- 7 raised warp thread
- 8 lowered warp thread
- 9 tie-up of shafts in pairs
- 10 treadling diagram
- 11 draft for basket weave (hopsack weave, matt weave)
- 12 pattern repeat
- 13 draft for warp rib weave
- 14 section of warp rib fabric, a section through the warp
- 15 lowered weft thread
- 16 raised weft thread
- 17 first and second warp threads [raised]
- 18 third and fourth warp threads [lowered]
- 19 draft for combined rib weave
- 20 selvedge (selvage) thread draft (additional shafts for the selvage)
- 21 draft for the fabric shafts
- 22 tie-up of selvage (selvage) shafts
- 23 tie-up of fabric shafts
- 24 selvedge (selvage) in plain weave
- 25 section through combination rib weave
- 26 thread interlacing of reversible warp-faced cord
- 27 draft (point paper design) for reversible warp-faced cord
- 28 interlacing points
- 29 weaving draft for honeycomb weave in the fabric

- 31 head
- 32 side
- 33 neck
- 34 head interlocking point
- 35 neck interlocking point
- 36 closed loop
- 37 mesh [with inlaid yarn]
- 38 diagonal floating yarn (diagonal floating thread)
- 39 loop interlocking at the head
- 40 float
- 41 loose floating yarn (loose floating thread)
- 42 course
- 43 inlaid yarn
- 44 tuck and miss stitch
- 45 pulled-up tuck stitch
- 46 staggered tuck stitch
- 47 2 x 2 tuck and miss stitch
- 48 double pulled-up tuck stitch

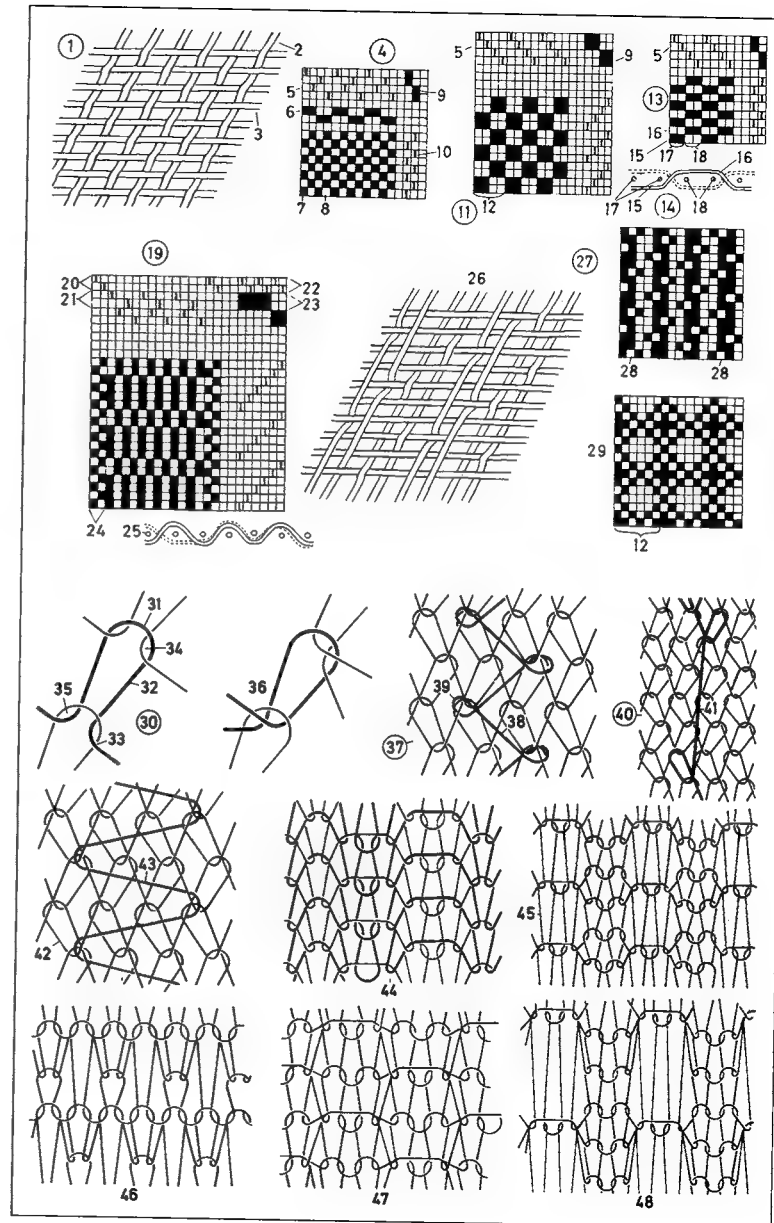

- 1-52 sulphate (*Am.* sulfate) pulp mill (kraft pulp mill) [in diagram form]
- 1 chippers with dust extractor
2 rotary screen (riffler)
3 chip packer (chip distributor)
4 blower
5 disintegrator (crusher, chip crusher)
6 dust-settling chamber
7 digester
8 liquor preheater
9 control tap
10 swing pipe
11 blow tank (diffuser)
12 blow valve
13 blow pit (diffuser)
14 turpentine separator
15 centralized separator
16 jet condenser (injection condenser)
17 storage tank for condensate
18 hot water tank
19 heat exchanger
20 filter
21 presorter
22 centrifugal screen
23 rotary sorter (rotary strainer)
24 concentrator (thickener, decker)
25 vat (chest)
26 collecting tank for backwater (low box)
27 conical refiner (cone refiner, Jordan, Jordan refiner)
28 black liquor filter
29 black liquor storage tank
30 condenser
31 separators
32 heaters (heating elements)
33 liquor pump
34 heavy liquor pump
35 mixing tank
36 salt cake storage tank (sodium sulphate storage tank)
37 dissolving tank (dissolver)
38 steam heater
39 electrostatic precipitator
40 air pump
41 storage tank for the unclarified green liquor
42 concentrator (thickener, decker)
43 green liquor preheater
44 concentrator (thickener, decker) for the weak wash liquor (wash water)
45 storage tank for the weak liquor
46 storage tank for the cooking liquor
47 agitator (stirrer)
48 concentrator (thickener, decker)
49 causticizing agitators (causticizing stirrers)
- 50 classifier
51 lime slaker
52 reconverted lime
53-65 groundwood mill (mechanical pulp mill) [diagram]
53 continuous grinder (continuous chain grinder)
54 strainer (knotter)
55 pulp water pump
56 centrifugal screen
57 screen (sorter)
58 secondary screen (secondary sorter)
59 rejects chest
60 conical refiner (cone refiner, Jordan, Jordan refiner)
61 pulp-drying machine (pulp machine)
62 concentrator (thickener, decker)
63 waste water pump (white water pump, pulp water pump)
64 steam pipe
65 water pipe
66 continuous grinder (continuous chain grinder)
67 feed chain
68 groundwood
69 reduction gear for the feed chain drive
70 stone-dressing device
71 grinding stone (grindstone, pulpstone)
72 spray pipe
73 conical refiner (cone refiner, Jordan, Jordan refiner)
74 handwheel for adjusting the clearance between the knives (blades)
75 rotating bladed cone (rotating bladed plug)
76 stationary bladed shell
77 inlet for unrefined cellulose (chemical wood pulp, chemical pulp) or groundwood pulp (mechanical pulp)
78 outlet for refined cellulose (chemical wood pulp, chemical pulp) or groundwood pulp (mechanical pulp)
79-86 stuff (stock) preparation plant [diagram]
79 conveyor belt (conveyor) for loading cellulose (chemical wood pulp, chemical pulp) or groundwood pulp (mechanical pulp)
80 pulper
81 dump chest
82 cone breaker
83 conical refiner (cone refiner, Jordan, Jordan refiner)
84 refiner
85 stuff chest (stock chest)
86 machine chest (stuff chest)

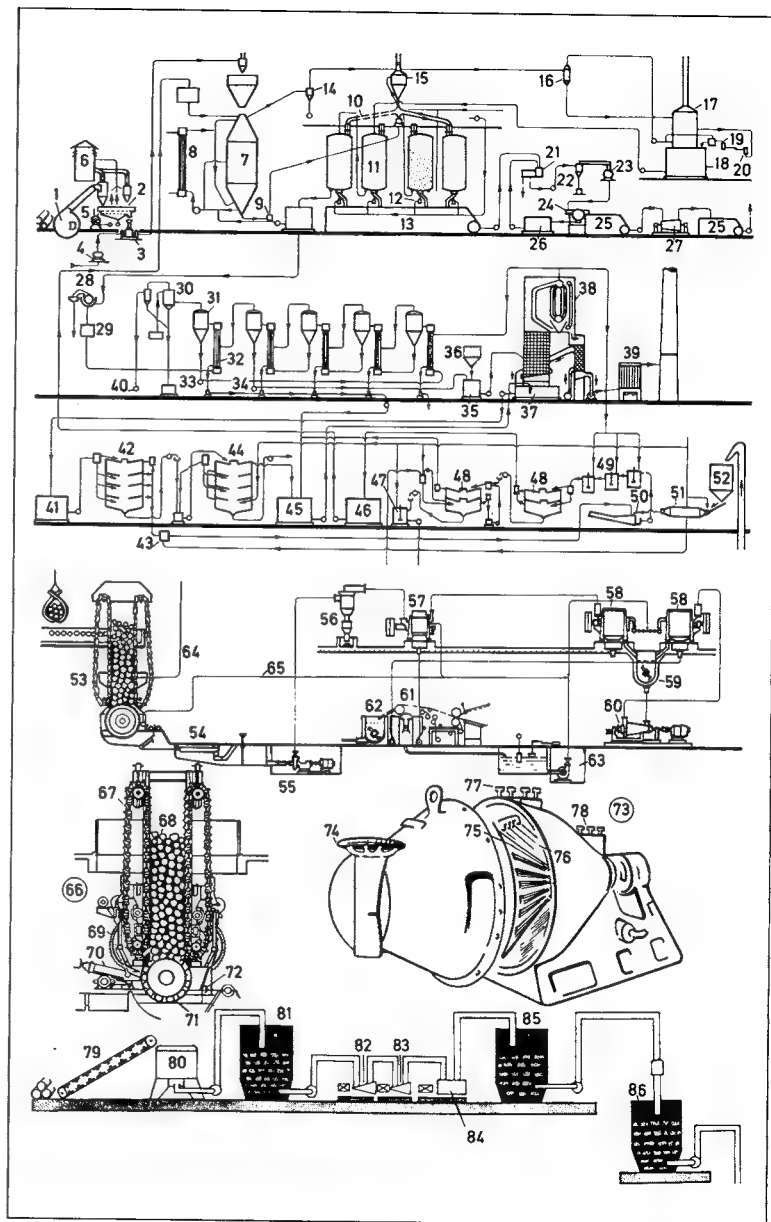

- 1 stuff chest (stock chest, machine chest), a mixing chest for stuff (stock)
- 2-10 laboratory apparatus (laboratory equipment) for analysing stuff (stock) and paper
- 2 Erlenmeyer flask
- 3 volumetric flask
- 4 measuring cylinder
- 5 Bunsen burner
- 6 tripod
- 7 petri dish
- 8 test tube rack
- 9 balance for measuring basis weight
- 10 micrometer
- 11 centrifugal cleaners ahead of the breastbox (headbox, stuff box) of a paper machine
- 12 standpipe
- 13-28 paper machine (production line) [diagram]
- 13 feed-in from the machine chest (stuff chest) with sand table (sand trap, riffler) and knotter
- 14 wire (machine wire)
- 15 vacuum box (suction box)
- 16 suction roll
- 17 first wet felt
- 18 second wet felt
- 19 first press
- 20 second press
- 21 offset press
- 22 drying cylinder (drier)
- 23 dry felt (drier felt)
- 24 size press
- 25 cooling roll
- 26 calender rolls
- 27 machine hood
- 28 delivery reel
- 29-35 blade coating machine (blade coater)
- 29 raw paper (body paper)
- 30 web
- 31 coater for the top side
- 32 infrared drier
- 33 heated drying cylinder
- 34 coater for the underside (wire side)

- 35 reel of coated paper
- 36 calender (super-calender)
- 37 hydraulic system for the press rolls
- 38 calender roll
- 39 unwind station
- 40 lift platform
- 41 rewind station (rewinder, re-reeler, reeling machine, re-reeling machine)
- 42 roll cutter
- 43 control panel
- 44 cutter
- 45 web
- 46-51 papermaking by hand
- 46 vatman
- 47 vat
- 48 mould (*Am. mold*)
- 49 coucher (couchman)
- 50 post ready for pressing
- 51 felt

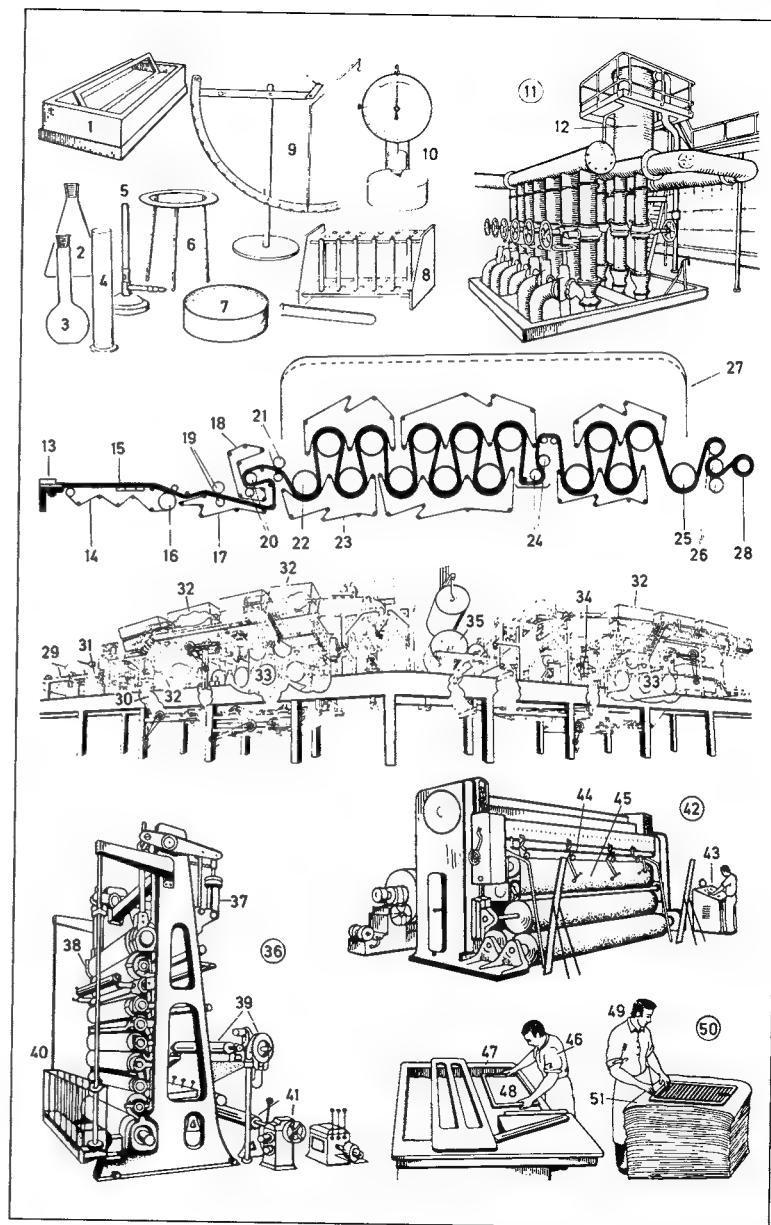

- 1 hand-setting room (hand-composing room)
- 2 composing frame
- 3 case (typecase)
- 4 case cabinet (case rack)
- 5 hand compositor (compositor, typesetter, maker-up)
- 6 manuscript (typescript)
- 7 sorts (types, type characters, characters)
- 8 rack (case) for furniture (spacing material)
- 9 standing type rack (standing matter rack)
- 10 storage shelf (shelf for storing formes, *Am.* forms)
- 11 standing type (standing matter)
- 12 galley
- 13 composing stick (setting stick)
- 14 composing rule (setting rule)
- 15 type (type matter, matter)
- 16 page cord
- 17 bodkin
- 18 tweezers
- 19 **Linotype line-composing (line-casting, slug-composing, slug-casting) machine, a multi-magazine machine**
- 20 distributing mechanism (distributor)
- 21 type magazines with matrices (matrixes)
- 22 elevator carrier for distributing the matrices (matrixes)
- 23 assembler
- 24 spacebands
- 25 casting mechanism
- 26 metal feeder
- 27 machine-set matter (cast lines, slugs)
- 28 matrices (matrixes) for hand-setting (sorts)
- 29 Linotype matrix
- 30 teeth for the distributing mechanism (distributor)
- 31 face (type face, matrix)

- 32-45 **monotype single-unit composing (typesetting) and casting machine (monotype single-unit composition caster)**
- 32 monotype standard composing (typesetting) machine (keyboard)
- 33 paper tower
- 34 paper ribbon
- 35 justifying scale
- 36 unit indicator
- 37 keyboard
- 38 compressed-air hose
- 39 monotype casting machine (monotype caster)
- 40 automatic metal feeder
- 41 pump compression spring (pump pressure spring)
- 42 matrix case (die case)
- 43 paper tower
- 44 galley with types (letters, characters, cast single types, cast single letters)
- 45 electric heater (electric heating unit)
- 46 matrix case (die case)
- 47 type matrices (matrixes) (letter matrixes)
- 48 guide block for engaging with the cross-slide guide

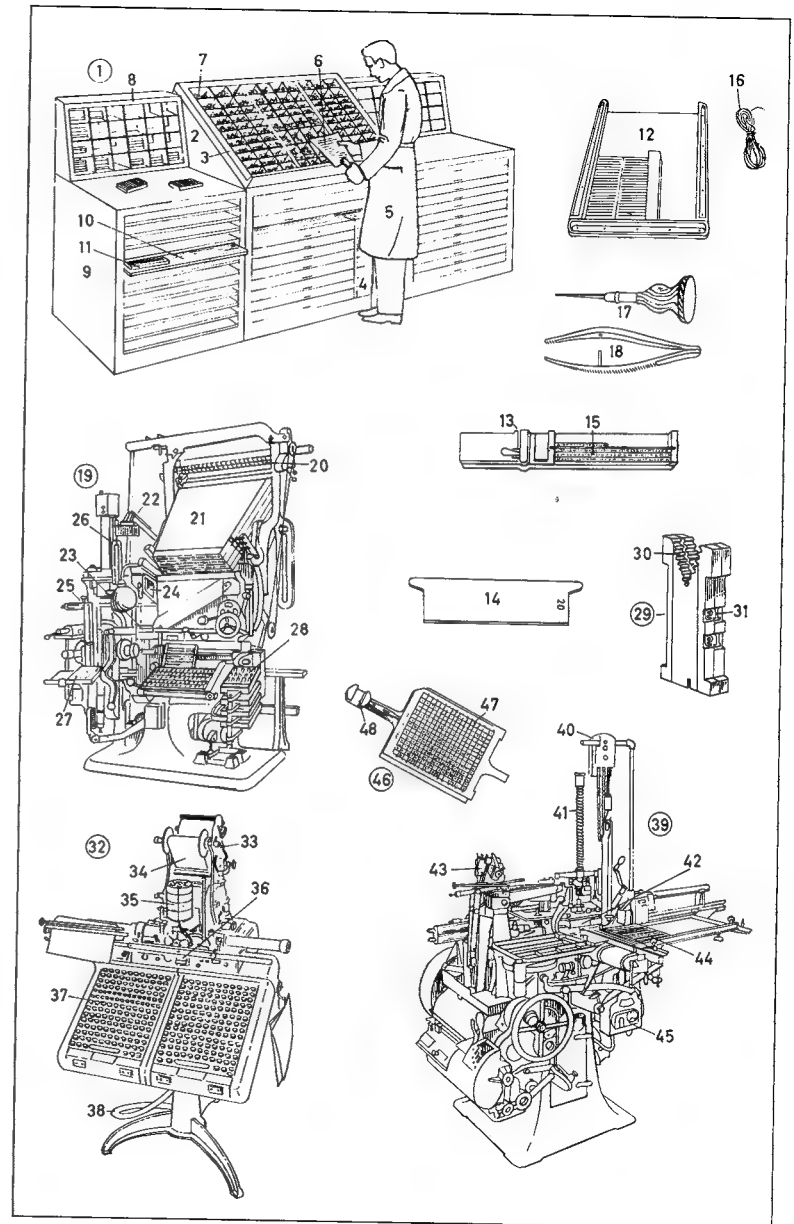

- 1-17 **composition** (type matter, type)
- 1 initial (initial letter)
- 2 bold type (bold, boldfaced type, heavy type, boldface)
- 3 semibold type (semibold)
- 4 line
- 5 space
- 6 ligature (double letter)
- 7 italic type (italics)
- 8 light face type (light face)
- 9 extra bold type (extra bold)
- 10 bold condensed type (bold condensed)
- 11 majuscule (capital letter, capital, upper case letter)
- 12 minuscule (small letter, lower case letter)
- 13 letter spacing (interspacing)
- 14 small capitals
- 15 break
- 16 indention
- 17 space
- 18 **type sizes** [one typographic point = 0.376 mm (Didot system), 0.351 mm (Pica system)]
- 19 six-to-pica (2 points)
- 20 half nonpareil (four-to-pica) (3 points)
- 21 brilliant (4 points); *sim.*: diamond (4½ points)
- 22 pearl (5 points); *sim.*: ruby (*Am. agate*) (5½ points)
- 23 nonpareil (6 points); *sim.*: minionette (6½ points)
- 24 minion (7 points)
- 25 brevier (8 points)
- 26 bourgeois (9 points)
- 27 long primer (10 points)
- 28 pica (12 points)
- 29 English (14 points)
- 30 great primer (two-line brevier, *Am. Columbian*) (16 points)
- 31 paragon (two-line primer) (20 points)
- 32-37 **typesetting** (type casting)
- 32 punch cutter
- 33 graver (burin, cutter)

- 34 magnifying glass (magnifier)
- 35 punch blank (die blank)
- 36 finished steel punch (finished steel die)
- 37 punched matrix (stamped matrix, strike, drive)
- 38 **type** (type character, character)
- 39 **head**
- 40 shoulder
- 41 counter
- 42 face (type face)
- 43 type line (bodyline)
- 44 height to paper (type height)
- 45 height of shank (height of shoulder)
- 46 body size (type size, point size)
- 47 nick
- 48 set (width)
- 49 **matrix-boring machine** (matrix-engraving machine), a special-purpose boring machine
- 50 stand
- 51 cutter (cutting head)
- 52 cutting table
- 53 pantograph carriage
- 54 V-way
- 55 pattern
- 56 pattern table
- 57 follower
- 58 pantograph
- 59 matrix clamp
- 60 cutter spindle
- 61 drive motor

1 3 9 2

Alfred John Dodsley, essayist and journalist⁴ was born in Wenlock on the 5th August 1841 and died on the 4th October 1920 in Birmingham. His father was a journeyman thatcher and as a boy Dodsley was sent to work in the fields as a bird-scarer. Having taught himself to read and write fluently — for many years the only books he possessed were a Bible and a volume of Tillotson's sermons — he went to Shrewsbury to study. Living in extreme poverty he began to write for the EAST HEREFORDSHIRE GAZETTE and a collection of his essays together with some poems on country life was published in 1868 under the title "Rural Thoughts". Among his most popular works were "The Diary of a Derbyshire Shepherd" (1872), "Rural Verses" (1879), "Leaves from a Countryman's Notebook" (1893) and "Memoirs of Nineteenth Century Shropshire", published posthumously. Dodsley also contributed many articles on country life to London papers and championed the cause of the agricultural worker during the depression of the 1880's. The latter years of his life were embittered by controversy raised by his protests against the unemployment caused by mechanised farming.

16— He was for many years president of the **Society for the Protection of the Liberties of the Farm-worker.**

18

19

20

21 N n

22 N n

23 N n

24 N n

25 N n

26 N n

27 N n

28 N n

29 N n

30 N n

31 N n

10 17

176 Typesetting Room III (Phototypesetting, Photocomposition, Photosetting)

- 1-21 phototypesetting configurations
- 1 off-line configuration
- 2, 3 data capture
- 2 terminal for keying unformatted text
- 3 text capture and correction terminal
- 4 layout terminal (page-layout terminal)
- 5 data carrier, a diskette (floppy disk)
- 6 (photo)typesetting unit (phototypesetter)
- 7 on-line configuration
- 8 make-up terminal (page make-up terminal)
- 9 central processing unit (typesetting computer)
- 10 magnetic tape unit (magnetic tape drive)
- 11 disk store
- 12 printer, a laser printer
- 13 phototypesetting machine (phototypesetter)
- 14 text capture (text-capture terminal)
- 15 typesetter (keyboarder or typographer)
- 16 screen (monitor)
- 17 floppy disk drive
- 18 computer and memory unit with central processing unit and hard disk
- 19 mouse, an input device
- 20 mouse mat
- 21 keyboard, an input device
- 22 direct-entry phototypesetter
- 23-33 desktop publishing (DTP)
- 23 diskette (floppy disk) with text, layout, and graphics programs
- 24 scanner (flat-bed scanner)
- 25 personal computer (PC) or workstation
- 26 printout (computer printout)
- 27 raster image processor (RIP)
- 28 laser phototypesetter
- 29 proof

- 30 high-resolution graphics screen, a large-format colour monitor
- 31 display window
- 32 typographic parameters
- 33 (typographic) command window
- 34 film copier
- 35-46 cathode ray tube (CRT) typesetter
- 35 scanning system
- 36 scan-generating (scanning) cathode ray tube (CRT)
- 37 lens
- 38 character grid (matrix case)
- 39 condenser lens
- 40 photomultiplier
- 41 output system
- 42 video amplifier
- 43 character-generating tube (CRT character generator)
- 44 exposure plane
- 45 matrix case
- 46 guide claw

Typesetting Room III (Phototypesetting, 176 Photocomposition, Photosetting)

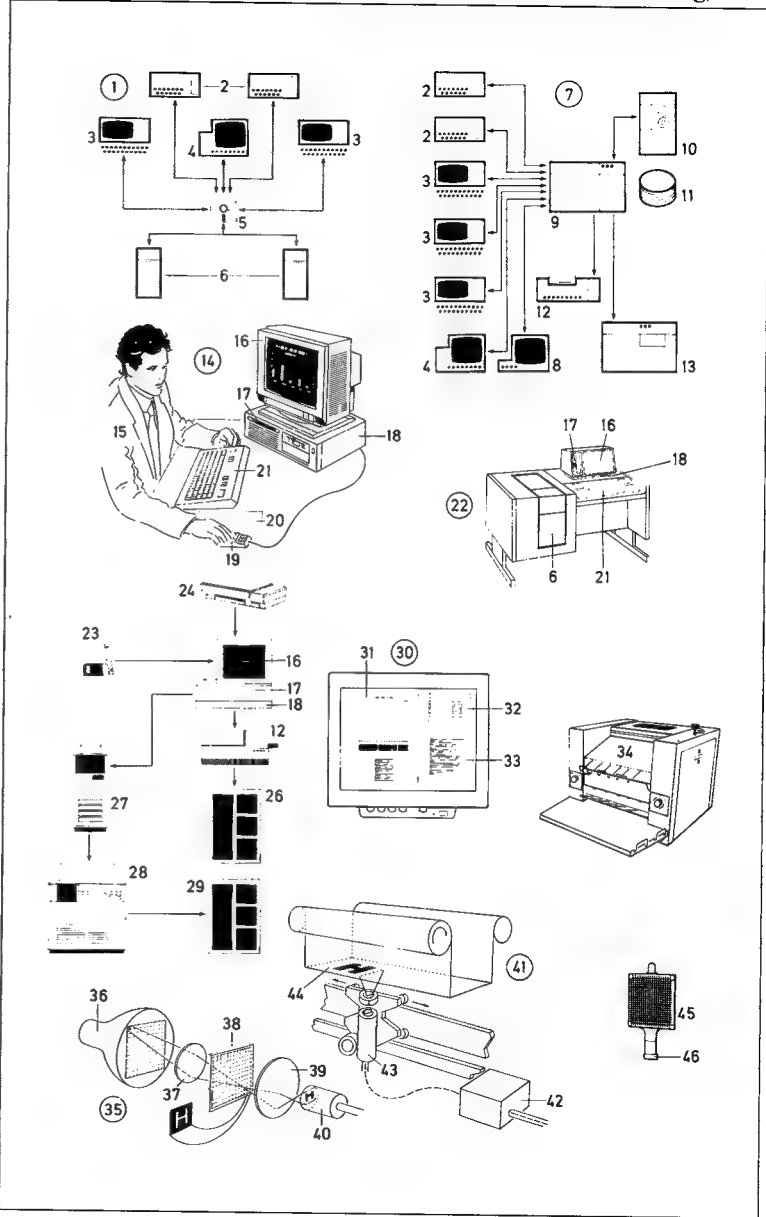

- 1 overhead process camera (overhead copying camera)
- 2 focusing screen (ground glass screen)
- 3 hinged screen holder
- 4 graticule
- 5 control console
- 6 hinged bracket-mounted control panel
- 7 percentage focusing charts
- 8 vacuum film holder
- 9 screen magazine
- 10 bellows
- 11 standard
- 12 register device
- 13 overhead gantry
- 14 copyboard
- 15 copyholder
- 16 lamp bracket
- 17 xenon lamp
- 18 copy (original)
- 19 retouching and stripping desk
- 20 illuminated screen
- 21 height and angle adjustment
- 22 copyboard
- 23 linen tester, a magnifying glass
- 24 universal process and reproduction camera
- 25 camera body
- 26 bellows
- 27 lens carrier
- 28 angled mirror
- 29 stand
- 30 copyboard
- 31 halogen lamp
- 32 vertical process camera, a compact camera
- 33 camera body
- 34 focusing screen (ground glass screen)
- 35 vacuum back
- 36 control panel
- 37 flash lamp
- 38 mirror for right-reading images
- 39 scanner (colour, *Am. color*, correction unit)
- 40 base frame

- 41 lamp compartment
- 42 xenon lamp housing
- 43 feed motors
- 44 transparency arm
- 45 scanning drum
- 46 scanning head
- 47 mask-scanning head
- 48 mask drum
- 49 recording space
- 50 daylight cassette
- 51 colour (*Am. color*) computer with control unit and selective colour correction
- 52 engraving machine
- 53 seamless engraving adjustment
- 54 drive clutch
- 55 clutch flange
- 56 drive unit
- 57 machine bed
- 58 equipment carrier
- 59 bed slide
- 60 control panel
- 61 bearing block
- 62 tailstock
- 63 scanning head
- 64 copy cylinder
- 65 centre (*Am. center*) bearing
- 66 engraving system
- 67 printing cylinder
- 68 cylinder arm
- 69 electronics (electronic) cabinet
- 70 computers
- 71 program input
- 72 automatic film processor for scanner films

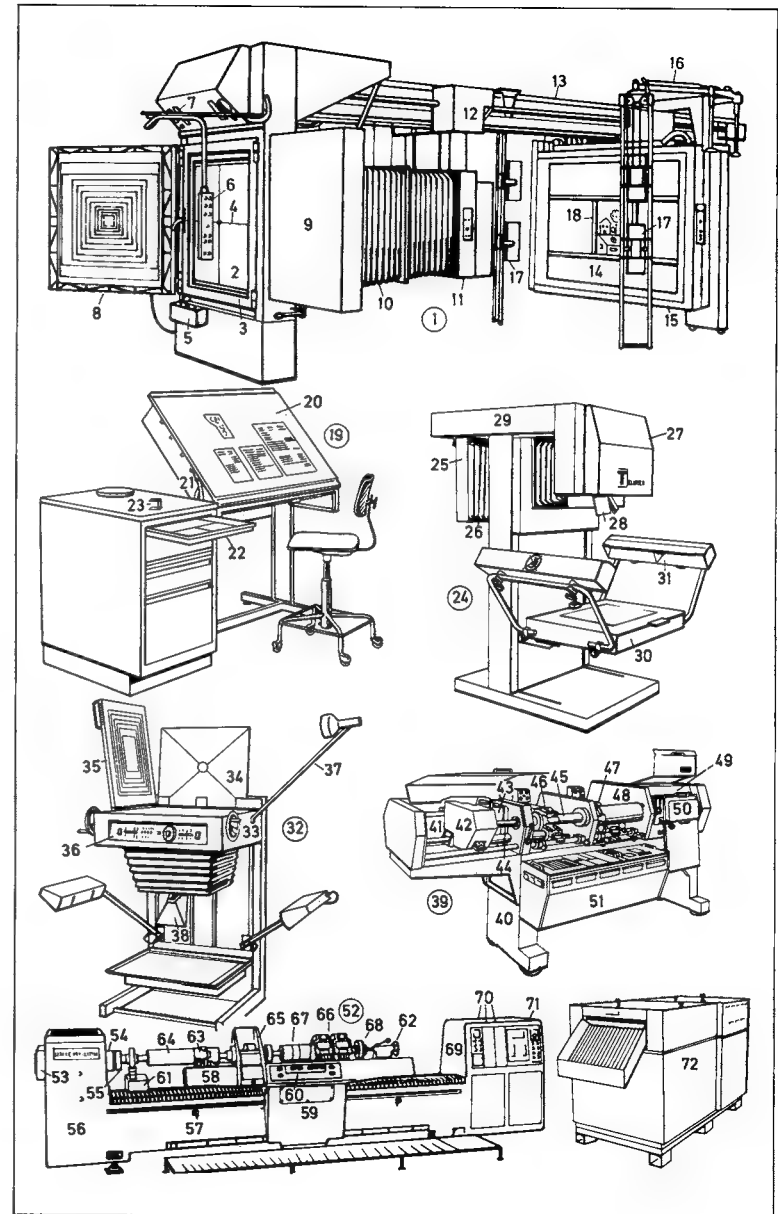

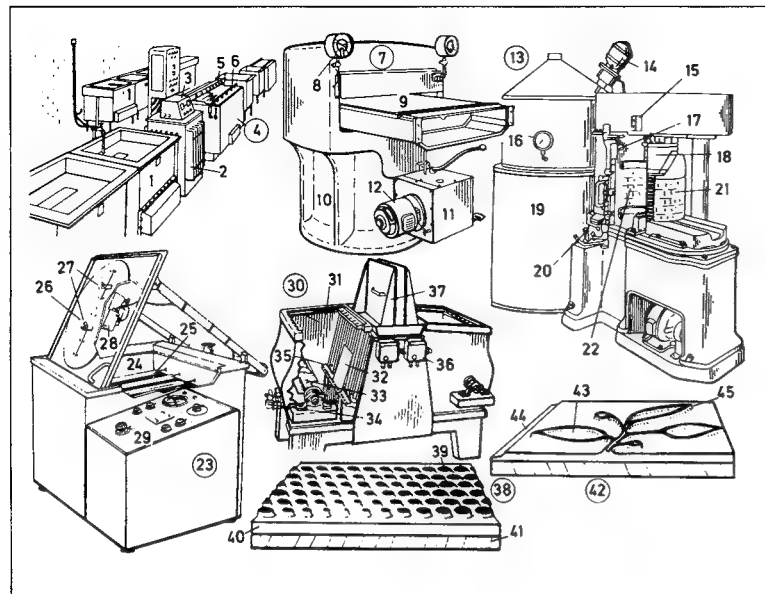
**1-6 electrotyping plant**

- 1 cleaning tank
- 2 rectifier
- 3 measuring and control unit
- 4 electroplating tank (electroplating bath, electroplating vat)
- 5 anode rod (with copper anodes)
- 6 plate rod (cathode)
- 7 **hydraulic moulding** (*Am.* molding press)
- 8 pressure gauge (*Am.* gage) (manometer)
- 9 apron
- 10 round base
- 11 hydraulic pressure pump
- 12 drive motor
- 13 **curved plate casting machine** (curved electrotype casting machine)
- 14 motor
- 15 control knobs
- 16 pyrometer
- 17 mouth piece
- 18 core
- 19 melting furnace
- 20 starting lever
- 21 cast curved plate (cast curved electrotype) for rotary printing
- 22 fixed mould (*Am.* mold)
- 23 **etching machine**

- 24 etching tank with etching solution (etchant, mordant) and filming agent (film former)
- 25 paddles
- 26 turntable
- 27 plate clamp
- 28 drive motor
- 29 control unit
- 30 **twin etching machine**
- 31 etching tank (etching bath) [in section]
- 32 photoprinted zinc plate
- 33 paddle
- 34 outlet cock (drain cock, *Am.* faucet)
- 35 plate rack
- 36 control switches
- 37 lid
- 38 **halftone photoengraving** (halftone block, halftone plate), a block (plate, printing plate)
- 39 dot (halftone dot), a printing element
- 40 etched zinc plate
- 41 block mount (block mounting, plate mount, plate mounting)
- 42 **line block** (line engraving, line etching, line plate, line cut)
- 43 non-printing, deep-etched areas
- 44 flange (bevel edge)
- 45 sidewall

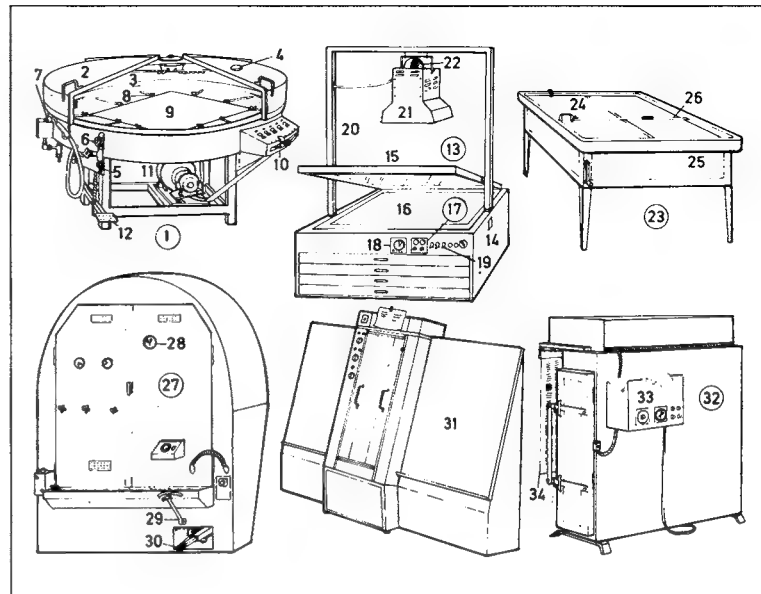

- 1 plate whirler (whirler, plate-coating machine) for coating offset plates
- 2 sliding lid
- 3 electric heater
- 4 temperature gauge (*Am.* gage)
- 5 water connection for the spray unit
- 6 spray unit
- 7 hand spray
- 8 plate clamps
- 9 zinc plate (*also:* magnesium plate, copper plate)
- 10 control panel
- 11 drive motor
- 12 brake pedal
- 13 vacuum printing frame (vacuum frame, printing-down frame)
- 14 base of the vacuum printing frame (vacuum frame, printing-down frame)
- 15 plate glass frame
- 16 coated offset plate
- 17 control panel
- 18 exposure timer
- 19 vacuum pump switches
- 20 support
- 21 point light exposure lamp, a quartz-halogen lamp
- 22 fan blower
- 23 stripping table (make-up table) for stripping films
- 24 crystal glass screen
- 25 light box
- 26 straightedge rules
- 27 vertical plate-drying cabinet
- 28 hygrometer
- 29 speed control
- 30 brake pedal
- 31 processing machine for presensitized plates
- 32 burning-in oven for glue-enamel plates (dialo plates)
- 33 control box (control unit)
- 34 diazo plate

- 1 four-colour (*Am.* four-color) rotary off-set press (rotary offset machine, web-offset press)
- 2 roll of unprinted paper (blank paper)
- 3 reel stand (carrier for the roll of unprinted paper)
- 4 forwarding rolls
- 5 side margin control (margin control, side control, side lay control)
- 6-13 inking units (inker units)
- 6, 8, 10, 12 inking units (inker units) in the upper printing unit
- 6, 7 perfecting unit (double unit) for yellow
- 7, 9, 11, 13 inking units (inker units) in the lower printing unit
- 8, 9 perfecting unit (double unit) for cyan
- 10, 11 perfecting unit (double unit) for magenta
- 12, 13 perfecting unit (double unit) for black
- 14 drier
- 15 folder (folder unit)
- 16 control desk
- 17 sheet
- 18 four-colour (*Am.* four-color) rotary off-set press (rotary offset machine, web-offset press) [diagram]
- 19 reel stand
- 20 side margin control (margin control, side control, side lay control)
- 21 inking rollers (ink rollers, inkers)
- 22 ink duct (ink fountain)
- 23 damping rollers (dampening rollers, dampers, dampeners)
- 24 blanket cylinder
- 25 plate cylinder
- 26 route of the paper (of the web)
- 27 drier
- 28 chilling rolls (cooling rollers, chill rollers)
- 29 folder (folder unit)
- 30 four-colour (*Am.* four-color) sheet-fed offset machine (offset press) [diagram]
- 31 sheet feeder (feeder)
- 32 feed table (feed board)
- 33 route of the sheets through swing-grippers to the feed drum
- 34 feed drum
- 35 impression cylinder
- 36 transfer drums (transfer cylinders)
- 37 blanket cylinder
- 38 plate cylinder
- 39 damping unit (dampening unit)
- 40 inking unit (inker unit)
- 41 printing unit
- 42 delivery cylinder

- 43 chain delivery
- 44 delivery pile
- 45 delivery unit (delivery mechanism)
- 46 single-colour (*Am.* single-color) offset press (offset machine)
- 47 pile of paper (sheets, printing paper)
- 48 sheet feeder (feeder), an automatic pile feeder
- 49 feed table (feed board)
- 50 inking rollers (ink rollers, inkers)
- 51 inking unit (inker unit)
- 52 damping rollers (dampening rollers, dampers, dampeners)
- 53 plate cylinder, a zinc plate
- 54 blanket cylinder, a steel cylinder with rubber blanket
- 55 pile delivery unit for the printed sheets
- 56 gripper bar, a chain gripper
- 57 pile of printed paper (printed sheets)
- 58 guard for the V-belt (vee-belt) drive
- 59 single-colour (*Am.* single-color) offset press (offset machine) [diagram]
- 60 inking unit (inker unit) with inking rollers (ink rollers, inkers)
- 61 damping unit (dampening unit) with damping rollers (dampening rollers, dampers, dampeners)
- 62 plate cylinder
- 63 blanket cylinder
- 64 impression cylinder
- 65 delivery cylinders with grippers
- 66 drive wheel
- 67 feed table (feed board)
- 68 sheet feeder (feeder)
- 69 pile of unprinted paper (blank paper, unprinted sheets, blank sheets)
- 70 small sheet-fed offset press
- 71 inking unit (inker unit)
- 72 suction feeder
- 73 pile feeder
- 74 instrument panel (control panel) with counter, pressure gauge (*Am.* gage), air regulator, and control switch for the sheet feeder (feeder)
- 75 flat-bed offset press (offset machine) ('Mailänder' proofing press, proof press)
- 76 inking unit (inker unit)
- 77 inking rollers (ink rollers, inkers)
- 78 bed (press bed, type bed, forme bed, *Am.* form bed)
- 79 cylinder with rubber blanket
- 80 starting and stopping lever for the printing unit
- 81 impression-setting wheel (impression-adjusting wheel)

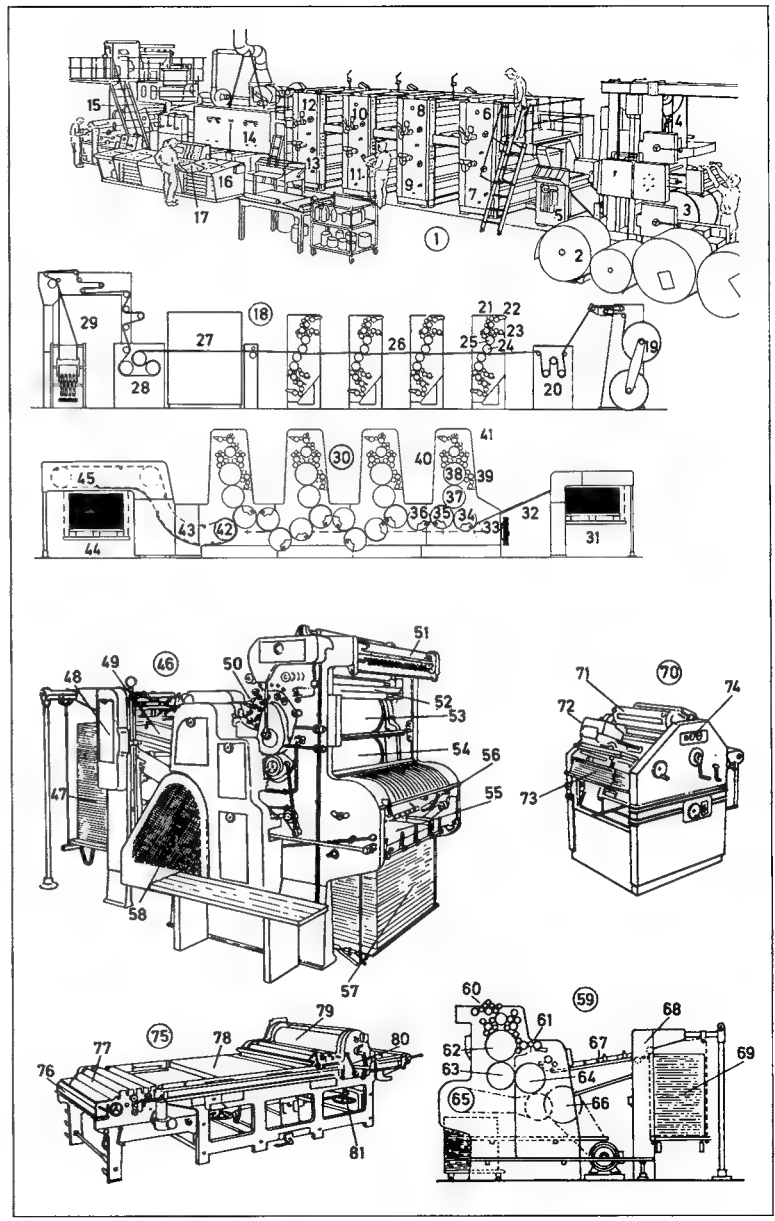

181 Letterpress Printing

1-65 presses (machines) for letterpress printing (letterpress printing machines)

1 two-revolution flat-bed cylinder press

2 impression cylinder

3 lever for raising or lowering the cylinder

4 feed table (feed board)

5 automatic sheet feeder (feeder)

[operated by vacuum and air blasts]

6 air pump for the feeder and delivery

7 inking unit (inker unit) with distributing rollers (distributor rollers, distributors) and forme rollers (*Am.* form rollers)

8 ink slab (ink plate) inking unit (inker unit)

9 delivery pile for printed paper

10 sprayer (anti set-off apparatus, anti set-off spray) for dusting the printed sheets

11 interleaving device

12 foot pedal for starting and stopping the press

13 platen press (platen machine, platen) [in section]

14 paper feed and delivery (paper feeding and delivery unit)

15 platen

16 toggle action (toggle-joint action)

17 bed (type bed, press bed, forme bed, *Am.* form bed)

18 forme rollers (*Am.* form rollers) (forme-inking, *Am.* form-inking, rollers)

19 inking unit (inker unit) for distributing the ink (printing ink)

20 stop-cylinder press (stop-cylinder machine)

21 feed table (feed board)

22 feeder mechanism (feeding apparatus, feeder)

23 pile of unprinted paper (blank paper, unprinted sheets, blank sheets)

24 guard for the sheet feeder (feeder)

25 pile of printed paper (printed sheets)

26 control mechanism

27 forme rollers (*Am.* form rollers) (forme-inking, *Am.* form-inking, rollers)

28 inking unit (inker unit)

29 [Heidelberg] platen press (platen machine, platen)

30 feed table (feed board) with pile of unprinted paper (blank paper, unprinted sheets, blank sheets)

31 delivery table

32 starting and stopping lever

33 delivery blower

34 spray gun (sprayer)

35 air pump for vacuum and air blasts

36 locked-up forme (*Am.* form)

37 type (type matter, matter)

38 chase

39 quoin

40 length of furniture

41 rotary letterpress press (rotary letterpress machine, web-fed letterpress machine) for newspapers of up to 16 pages

42 slitters for dividing the width of the web

43 web

44 impression cylinder

45 jockey roller (compensating roller, compensator, tension roller)

46 roll of paper

47 automatic brake

48 first printing unit

49 perfecting unit

50 inking unit (inker unit)

51 plate cylinder

52 second printing unit

53 former

54 tachometer with sheet counter

55 folder (folder unit)

56 folded newspaper

57 inking unit (inker unit) for the rotary press (web-fed press) [in section]

58 web

59 impression cylinder

60 plate cylinder

61 forme rollers (*Am.* form rollers) (forme-inking, *Am.* form-inking, rollers)

62 distributing rollers (distributor rollers, distributors)

63 lifter roller (ductor, ductor roller)

64 duct roller (fountain roller, ink fountain roller)

65 ink duct (ink fountain)

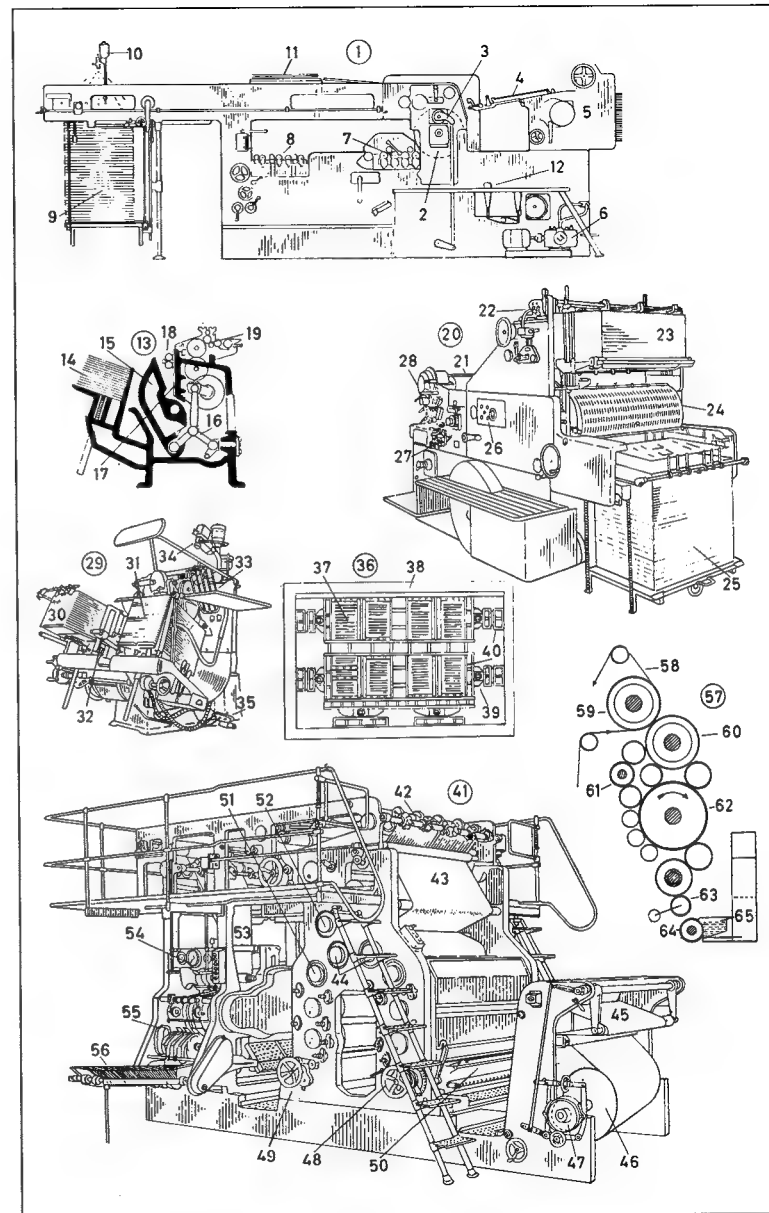

- 1 exposure of the carbon tissue (pigment paper)
- 2 vacuum frame
- 3 exposing lamp, a bank of quartz-halogen lamps
- 4 point source lamp
- 5 heat extractor
- 6 carbon tissue transfer machine (laydown machine, laying machine)
- 7 polished copper cylinder
- 8 rubber roller for pressing on the printed carbon tissue (pigment paper)
- 9 cylinder-processing machine
- 10 gravure cylinder coated with carbon tissue (pigment paper)
- 11 developing tank
- 12 staging
- 13 developed cylinder
- 14 retoucher painting out (stopping out)
- 15 etching machine
- 16 etching tank with etching solution (etchant, mordant)
- 17 printed gravure cylinder
- 18 gravure etcher
- 19 calculator dial
- 20 timer
- 21 revising (correcting) the cylinder
- 22 etched gravure cylinder
- 23 ledge
- 24 multicolour (*Am.* multicolor) rotogravure press
- 25 exhaust pipe for solvent fumes
- 26 reversible printing unit
- 27 folder (folder unit)
- 28 control desk
- 29 newspaper delivery unit
- 30 conveyor belt (conveyor)
- 31 bundled stack of newspapers

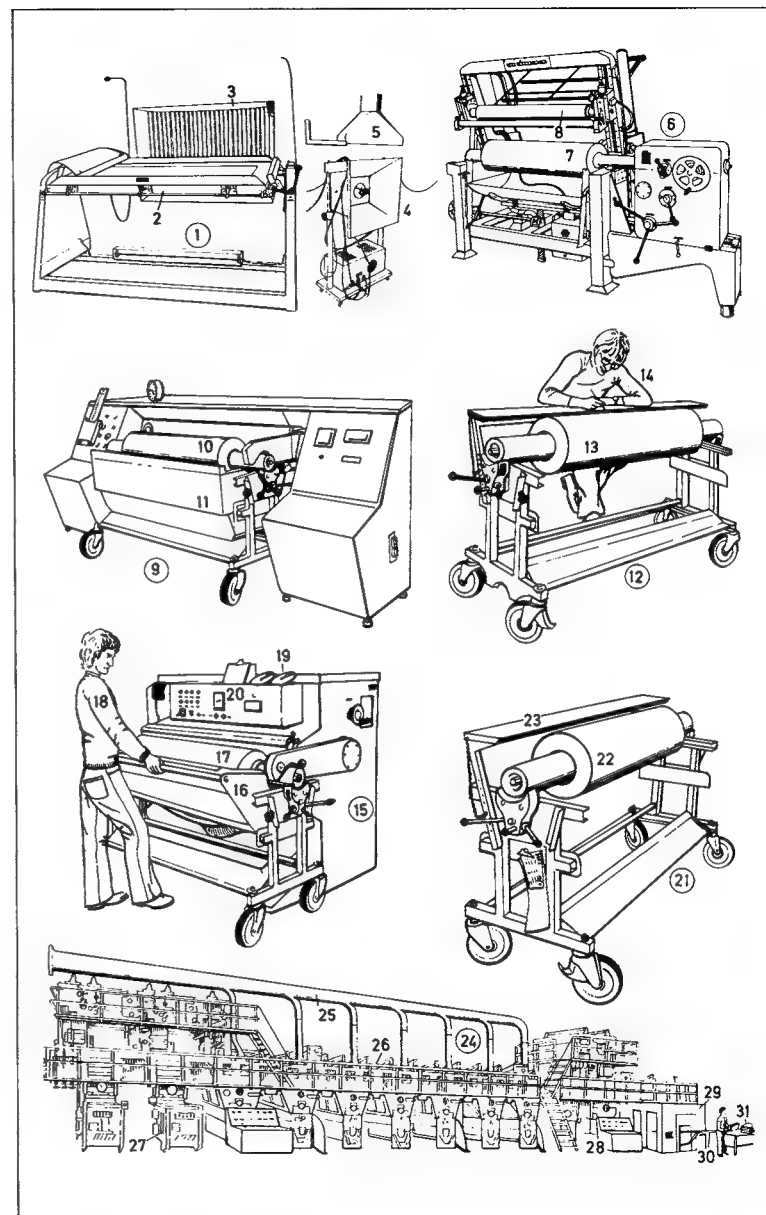

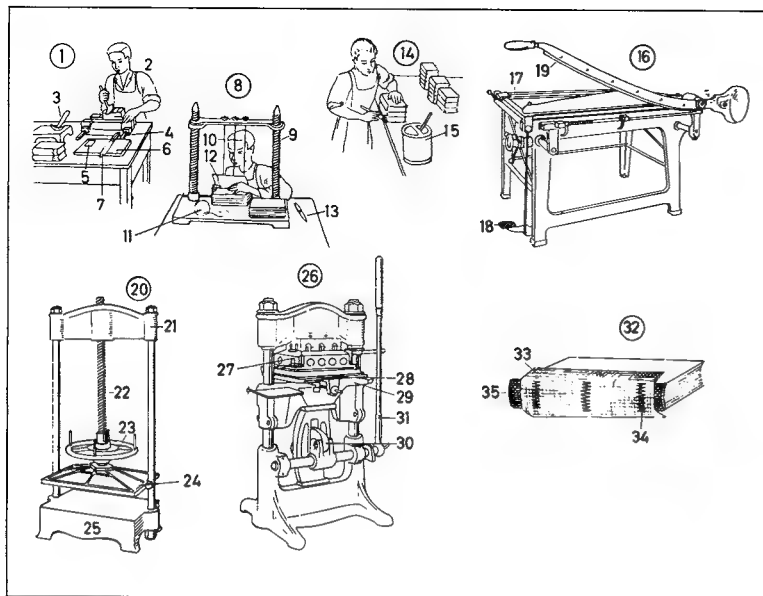

1-35 hand bookbindery (hand bindery)

- 1 gilding the spine of the book
- 2 gold finisher (gilder), a bookbinder
- 3 fillet
- 4 holding press (finishing press)
- 5 gold leaf
- 6 gold cushion
- 7 gold knife
- 8 sewing (stitching)
- 9 sewing frame
- 10 sewing cord
- 11 ball of thread (sewing thread)
- 12 section (signature)
- 13 bookbinder's knife
- 14 gluing the spine
- 15 glue pot
- 16 board cutter (guillotine)
- 17 back gauge (*Am.* gage)
- 18 clamp with foot pedal
- 19 cutting blade
- 20 standing press, a nipping press
- 21 head piece (head beam)

- 22 spindle
- 23 handwheel
- 24 platen
- 25 bed (base)
- 26 gilding (gold blocking) and embossing press, a hand-lever press; *sim.*: toggle-joint press (toggle-lever press)
- 27 heating box
- 28 sliding plate
- 29 embossing platen
- 30 toggle action (toggle-joint action)
- 31 hand lever
- 32 book sewn on gauze (mull, scrim) (book block)
- 33 gauze (mull, scrim)
- 34 sewing (stitching)
- 35 headband

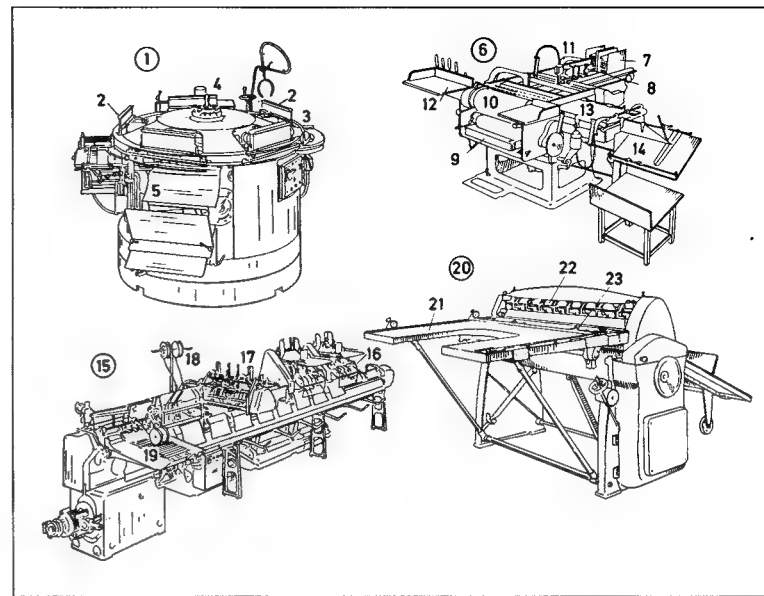

1-23 bookbinding machines

- 1 adhesive binder (perfect binder) for short runs
- 2 manual feed station
- 3 cutoff knife and roughing station
- 4 gluing mechanism
- 5 delivery (book delivery)
- 6 case maker (case-making machine)
- 7 board feed hoppers
- 8 pick-up suckers
- 9 glue tank
- 10 cover cylinder
- 11 picker head
- 12 feed table for covering materials [linen, paper, leather]
- 13 pressing mechanism
- 14 delivery table
- 15 gang stitcher (gathering and wire-stitching machine, gatherer and wire stitcher)
- 16 sheet feeder (sheet-feeding station)
- 17 folder-feeding station

- 18 stitching wire feed mechanism
- 19 delivery table
- 20 rotary board cutter (rotary board-cutting machine)
- 21 feed table with cut-out section
- 22 rotary cutter
- 23 feed guide

1-35 bookbinding machines

- 1 guillotine (guillotine cutter, automatic guillotine cutter)
- 2 control panel
- 3 clamp
- 4 back gauge (*Am. gage*)
- 5 calibrated pressure adjustment [to clamp]
- 6 illuminated cutting scale
- 7 single-hand control for the back gauge (*Am. gage*)
- 8 combined buckle and knife folding machine (combined buckle and knife folder)
- 9 feed table (feed board)
- 10 fold plates
- 11 stop for making the buckle fold
- 12 cross fold knives
- 13 belt delivery for parallel-folded signatures
- 14 third cross fold unit
- 15 delivery tray for cross-folded signatures
- 16 sewing machine (book-sewing machine)
- 17 spool holder
- 18 thread cop (thread spool)
- 19 gauze roll holder (mull roll holder, scrim roll holder)
- 20 gauze (mull, scrim)
- 21 needle cylinders with sewing needles
- 22 sewn book
- 23 delivery
- 24 reciprocating saddle
- 25 sheet feeder (feeder)
- 26 feed hopper
- 27 casing-in machine
- 28 joint and side pasting attachment
- 29 blade
- 30 preheater unit
- 31 gluing machine for whole-surface, stencil, edge, and strip gluing
- 32 glue tank
- 33 glue roller
- 34 feed table
- 35 delivery

36 book

- 37 dust jacket (dust cover, book jacket, wrapper), a publisher's wrapper
- 38 jacket flap
- 39 blurb
- 40-42 binding
- 40 cover (book cover, case)
- 41 spine (backbone, back)
- 42 tailband (footband)
- 43-47 preliminary matter (prelims, front matter)
- 43 half-title
- 44 half-title (bastard title, fly title)
- 45 title page
- 46 full title (main title)
- 47 subtitle
- 48 publisher's imprint (imprint)
- 49 fly leaf (endpaper, endleaf)
- 50 handwritten dedication
- 51 bookplate (*ex libris*)
- 52 open book
- 53 page
- 54 fold
- 55-58 margin
- 55 back margin (inside margin, gutter)
- 56 head margin (upper margin)
- 57 fore edge margin (outside margin, fore edge)
- 58 tail margin (foot margin, tail, foot)
- 59 type area
- 60 chapter heading
- 61 asterisk
- 62 footnote
- 63 page number
- 64 double-column page
- 65 column
- 66 running title (running head)
- 67 caption
- 68 marginal note (side note)
- 69 signature (signature code)
- 70 attached bookmark (attached bookmarker)
- 71 loose bookmark (loose bookmarker)

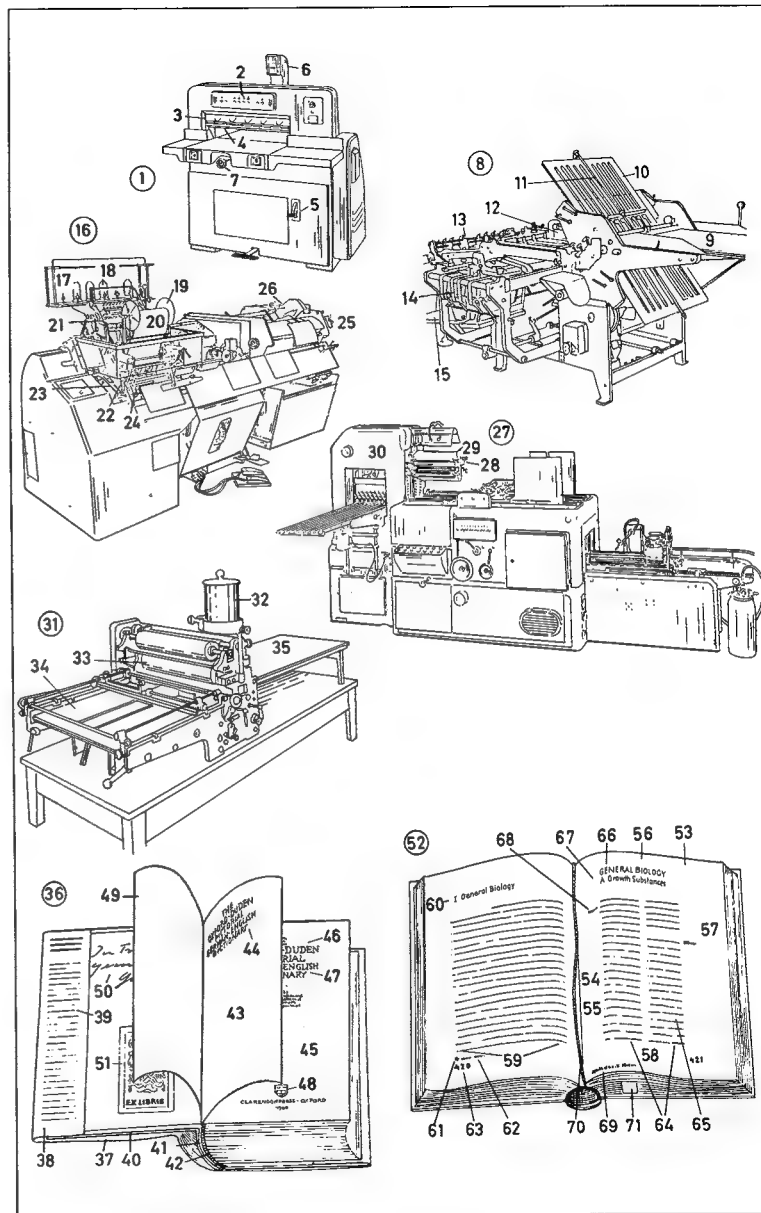

1-54 carriages (horse-drawn vehicles)

1-3, 26-39, 45, 51-54 carriages and coaches (coach wagons)

- 1 berlin
 2 wagonette; *larger*: brake (break)
 3 coupé; *sim.*: brougham
 4 front wheel
 5 coach body
 6 dashboard (splashboard)
 7 footboard
 8 coach box (box, coachman's seat, driver's seat)
 9 lamp (lantern)
 10 window
 11 door (coach door)
 12 door handle (handle)
 13 footboard (carriage step, coach step, step, footpiece)
 14 fixed top
 15 spring
 16 brake (brake block)
 17 back wheel (rear wheel)
 18 dogcart, a one-horse carriage
 19 shafts (thills, poles)
 20 lackey (lacquey, footman)
 21 livery
 22 braided (gallooned) collar
 23 braided (gallooned) coat
 24 braided (gallooned) sleeve
 25 top hat
 26 hackney carriage (hackney coach, cab, growler, *Am.* hack)
 27 stableman (groom)
 28 coach horse (carriage horse, cab horse, thill horse, thiller)
 29 hansom cab (hansom), a cabriolet, a one-horse chaise (one-horse carriage)
 30 shafts (thills, poles)
 31 reins (rein, *Am.* line)
 32 coachman (driver) with inverness
 33 covered char-a-banc (brake, break), a pleasure vehicle
 34 gig (chaise)
 35 barouche
 36 landau, a two-horse carriage; *sim.*: landaulet, landauette

- 37 omnibus (horse-drawn omnibus)
 38 phaeton
 39 Continental stagecoach (mail-coach, diligence); *also*: road coach
 40 mailcoach driver
 41 posthorn
 42 hood
 43 post horses (relay horses, relays)
 44 tilbury
 45 troika (Russian three-horse carriage)
 46 leader
 47 wheeler (wheelhorse, pole horse)
 48 English buggy
 49 American buggy
 50 tandem
 51 vis-à-vis
 52 collapsible hood (collapsible top)
 53 mailcoach (English stagecoach)
 54 covered (closed) chaise

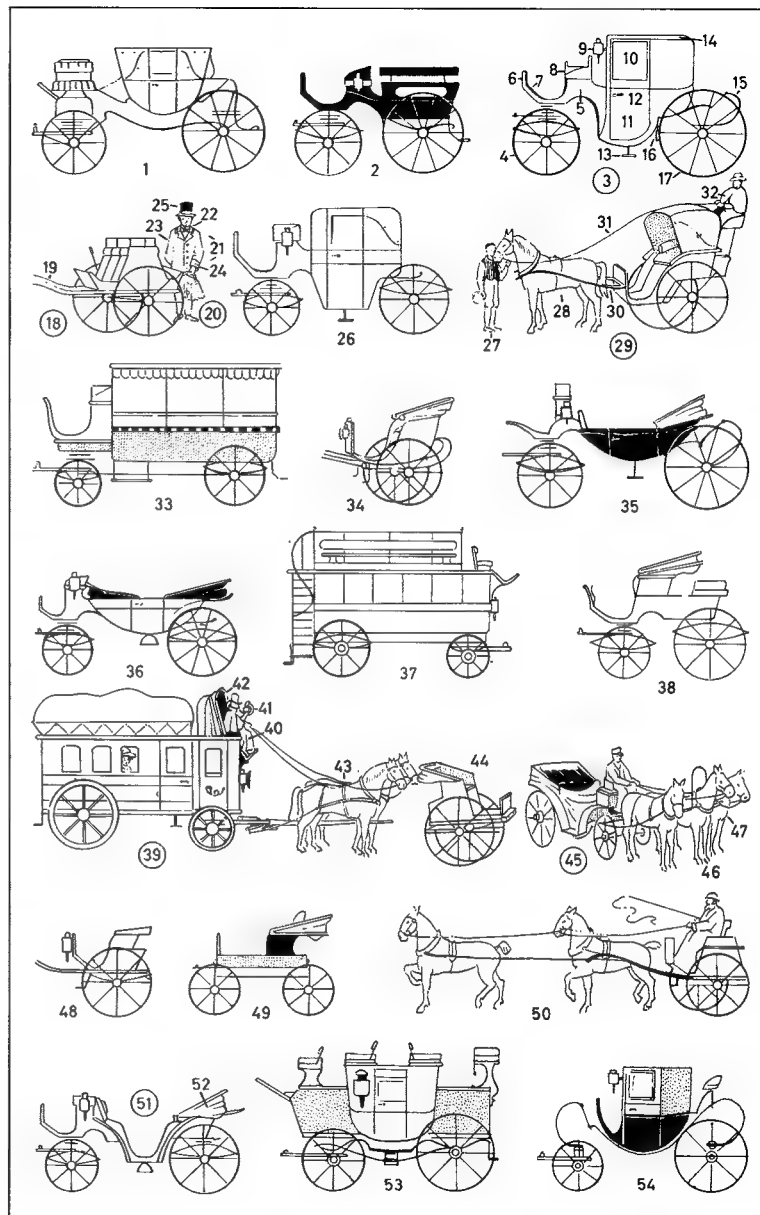

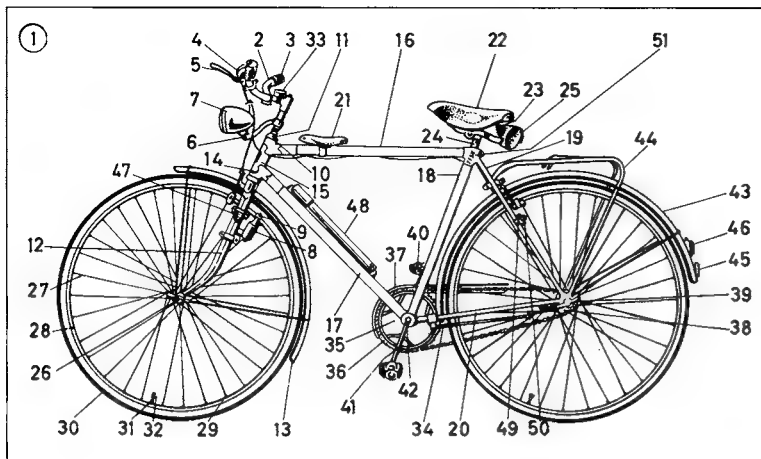

- | | |
|---|---|
| 1 bicycle (cycle, <i>coll.</i> bike, <i>Am.</i> wheel), a gent's bicycle, a touring bicycle (touring cycle, roadster) | 23 saddle springs |
| 2 handlebar (handlebars), a touring cycle handlebar | 24 seat pillar |
| 3 handlebar grip (handgrip, grip) | 25 tool bag |
| 4 bicycle bell | 26-32 wheel (front wheel) |
| 5 hand brake (front brake), a rim brake | 26 hub |
| 6 lamp bracket | 27 spoke |
| 7 headlamp (bicycle lamp) | 28 rim (wheel rim) |
| 8 dynamo | 29 spoke nipple (spoke flange, spoke end) |
| 9 pulley | 30 tyre (<i>Am.</i> tire) (pneumatic tyre, high-pressure tyre); <i>inside</i> : tube (inner tube); <i>outside</i> : tyre (outer case, cover) |
| 10-12 front forks | 31 valve, a tube valve with valve tube or a patent valve with ball |
| 10 handlebar stem | 32 valve sealing cap |
| 11 steering head | 33 bicycle speedometer with milometer |
| 12 fork blades (fork ends) | 34 kick stand (prop stand) |
| 13 front mudguard (<i>Am.</i> front fender) | 35-42 bicycle drive (chain drive) |
| 14-20 bicycle frame | 35 chain wheel |
| 14 steering tube (fork column) | 35-39 chain transmission |
| 15 head badge | 36 chain, a roller chain |
| 16 crossbar (top tube) | 37 chain guard |
| 17 down tube | 38 sprocket wheel (sprocket) |
| 18 seat tube | 39 wing nut (fly nut, butterfly nut) |
| 19 seat stays | 40 pedal |
| 20 chain stays | 41 crank |
| 21 child's seat (child carrier seat) | 42 bottom bracket bearing |
| 22 bicycle saddle | |

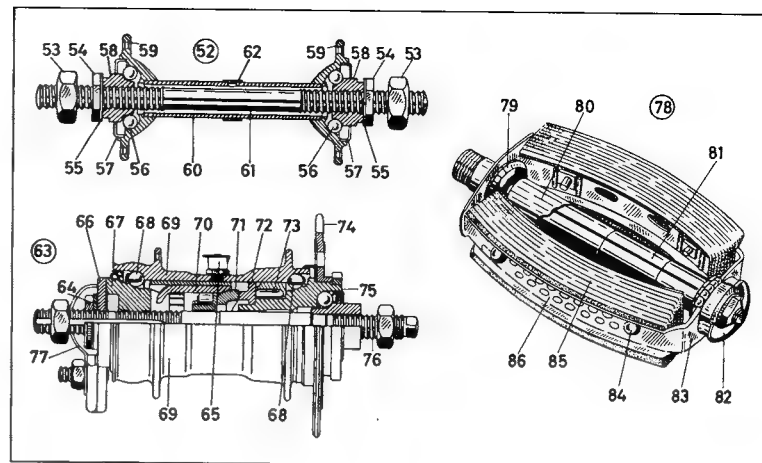

- | | |
|--|--|
| 43 rear mudguard (<i>Am.</i> rear fender) | 67 brake arm cone |
| 44 luggage carrier (carrier) | 68 bearing cup with ball bearings in ball race |
| 45 reflector | 69 hub shell (hub body, hub barrel) |
| 46 rear light (rear lamp) | 70 brake casing |
| 47 footrest | 71 brake cone |
| 48 bicycle pump | 72 driver |
| 49 bicycle lock, a wheel lock | 73 driving barrel |
| 50 patent key | 74 sprocket |
| 51 cycle serial number (factory number, frame number) | 75 thread head |
| 52 front hub (front hub assembly) | 76 axle |
| 53 wheel nut | 77 bracket |
| 54 locknut (locking nut) | 78 bicycle pedal (pedal, reflector pedal) |
| 55 washer (slotted cone adjusting washer) | 79 cup |
| 56 ball bearing | 80 spindle |
| 57 cone (adjusting cone) | 81 axle |
| 58 cone (adjusting cone) | 82 dust cap |
| 59 centre (<i>Am.</i> center) hub | 83 pedal frame |
| 60 spindle | 84 rubber stud |
| 61 axle | 85 rubber block (rubber tread) |
| 62 clip covering lubrication hole (lubricator) | 86 glass reflector |
| 63 free-wheel hub with back-pedal brake (with coaster brake) | |
| 64 safety nut | |
| 65 lubricator | |
| 66 brake arm | |

- 1 folding bicycle
- 2 hinge (*also*: locking lever)
- 3 adjustable handlebar (handlebars)
- 4 adjustable saddle
- 5 stabilizers
- 6 motor-assisted bicycle
- 7 air-cooled two-stroke engine
- 8 telescopic forks
- 9 tubular frame
- 10 fuel tank (petrol tank, *Am.* gasoline tank)
- 11 semi-rise handlebars
- 12 two-speed gear-change (gearshift)
- 13 high-back polo saddle
- 14 swinging-arm rear fork
- 15 upswept exhaust
- 16 heat shield
- 17 drive chain
- 18 crash bar (roll bar)
- 19 speedometer (*coll.* speedo)
- 20 battery-powered moped, an electrically-powered vehicle
- 21 swivel saddle
- 22 battery compartment
- 23 wire basket
- 24 touring moped (moped)
- 25 pedal crank (pedal drive, starter pedal)
- 26 single-cylinder two-stroke engine
- 27 spark-plug cap
- 28 fuel tank (petrol tank, *Am.* gasoline tank)
- 29 moped headlamp (front lamp)
- 30-35 handlebar fittings
- 30 twist grip throttle control (throttle twist grip)
- 31 twist grip (gear-change, gearshift)
- 32 clutch lever
- 33 hand brake lever
- 34 speedometer (*coll.* speedo)
- 35 rear-view mirror (mirror)
- 36 front wheel drum brake (drum brake)
- 37 Bowden cables (brake cables)
- 38 stop and tail light unit
- 39 light motorcycle with kickstarter

- 40 housing for instruments with speedometer and electronic rev counter (revolution counter)
- 41 telescopic shock absorber
- 42 twin seat
- 43 kickstarter
- 44 pillion footrest, a footrest
- 45 handlebar (handlebars)
- 46 chain guard
- 47 motor scooter (scooter)
- 48 removable side panel
- 49 tubular frame
- 50 metal fairings
- 51 prop stand (stand)
- 52 foot brake
- 53 horn (hooter)
- 54 hook for handbag or briefcase
- 55 foot gear-change control (foot gearshift control)
- 56 high-riser; *sim.*: Chopper
- 57 high-rise handlebar (handlebars)
- 58 imitation motorcycle fork
- 59 banana saddle
- 60 chrome bracket

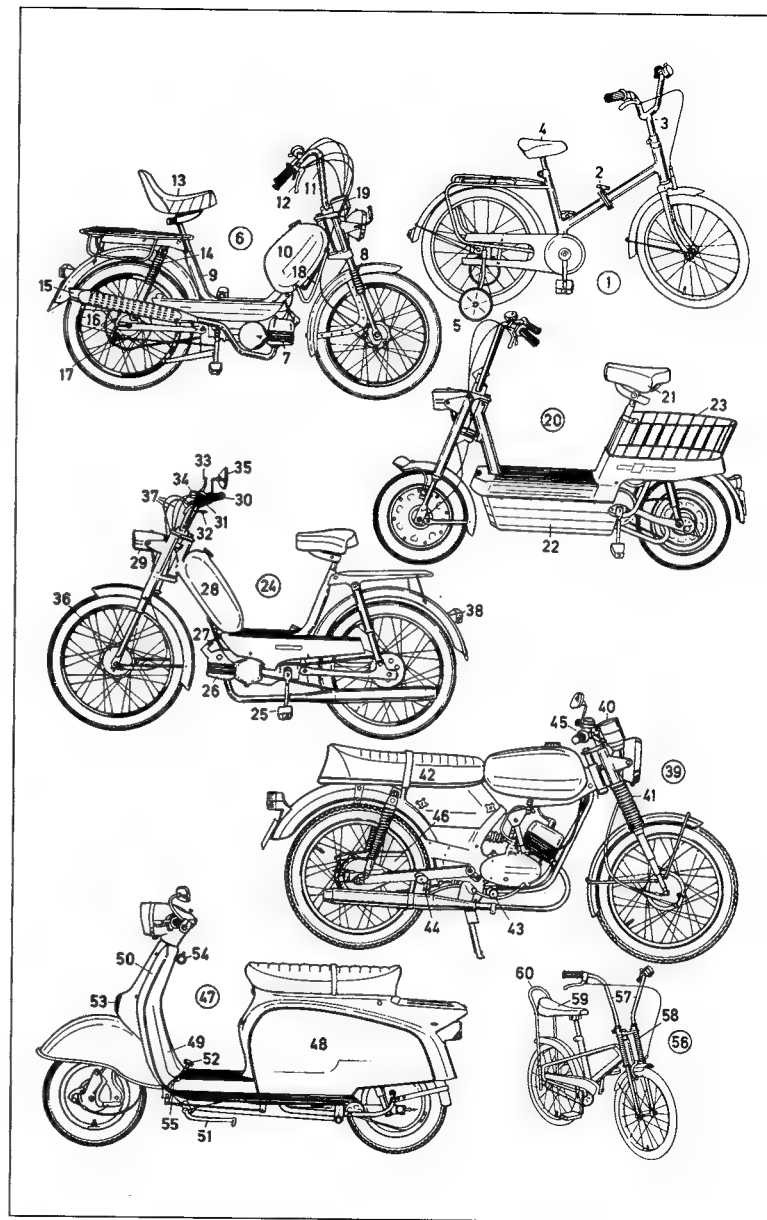

189 Motorcycle

- 1 lightweight motorcycle (light motorcycle) [50 cc]
- 2 fuel tank (petrol tank, *Am.* gasoline tank)
- 3 air-cooled single-cylinder four-stroke engine (with overhead camshaft)
- 4 carburettor (*Am.* carburetor)
- 5 intake pipe
- 6 five-speed gearbox
- 7 swinging-arm rear fork
- 8 number plate (*Am.* license plate)
- 9 stop and tail light (rear light)
- 10 headlight (headlamp)
- 11 front drum brake
- 12 brake cable (brake line), a Bowden cable
- 13 rear drum brake
- 14 racing-style twin seat
- 15 upswept exhaust
- 16 scrambling motorcycle (cross-country motorcycle) [125 cc], a light motorcycle
- 17 lightweight cradle frame
- 18 number disc (disk)
- 19 solo seat
- 20 cooling ribs
- 21 motorcycle stand
- 22 motorcycle chain
- 23 telescopic shock absorber
- 24 spokes
- 25 rim (wheel rim)
- 26 motorcycle tyre (*Am.* tire)
- 27 tyre (*Am.* tire) tread
- 28 gear-change lever (gearshift lever)
- 29 twist grip throttle control (throttle twist grip)
- 30 rear-view mirror (mirror)
- 31-58 heavy (heavyweight, large-capacity) motorcycles
- 31 heavyweight motorcycle with water-cooled engine
- 32 front disc (disk) brake
- 33 disc (disk) brake calliper (caliper)
- 34 floating axle
- 35 water cooler

- 36 fuel tank (petrol tank, *Am.* gasoline tank)
- 37 indicator (indicator light, turn indicator light)
- 38 kickstarter
- 39 water-cooled engine
- 40 speedometer
- 41 rev counter (revolution counter)
- 42 rear indicator (indicator light)
- 43 heavy (heavyweight, high-performance) machine with fairing [1000 cc]
- 44 integrated streamlining, an integrated fairing
- 45 indicator (indicator light, turn indicator light)
- 46 anti-mist windscreen (*Am.* windshield)
- 47 horizontally-opposed twin engine with cardan transmission
- 48 light alloy wheel
- 49 four-cylinder machine [400 cc]
- 50 air-cooled four-cylinder four-stroke engine
- 51 four-pipe megaphone exhaust pipe
- 52 electric starter button
- 53 sidecar machine
- 54 sidecar body
- 55 sidecar crash bar
- 56 sidelight (*Am.* sidemarker lamp)
- 57 sidecar wheel
- 58 sidecar windscreen (*Am.* windshield)

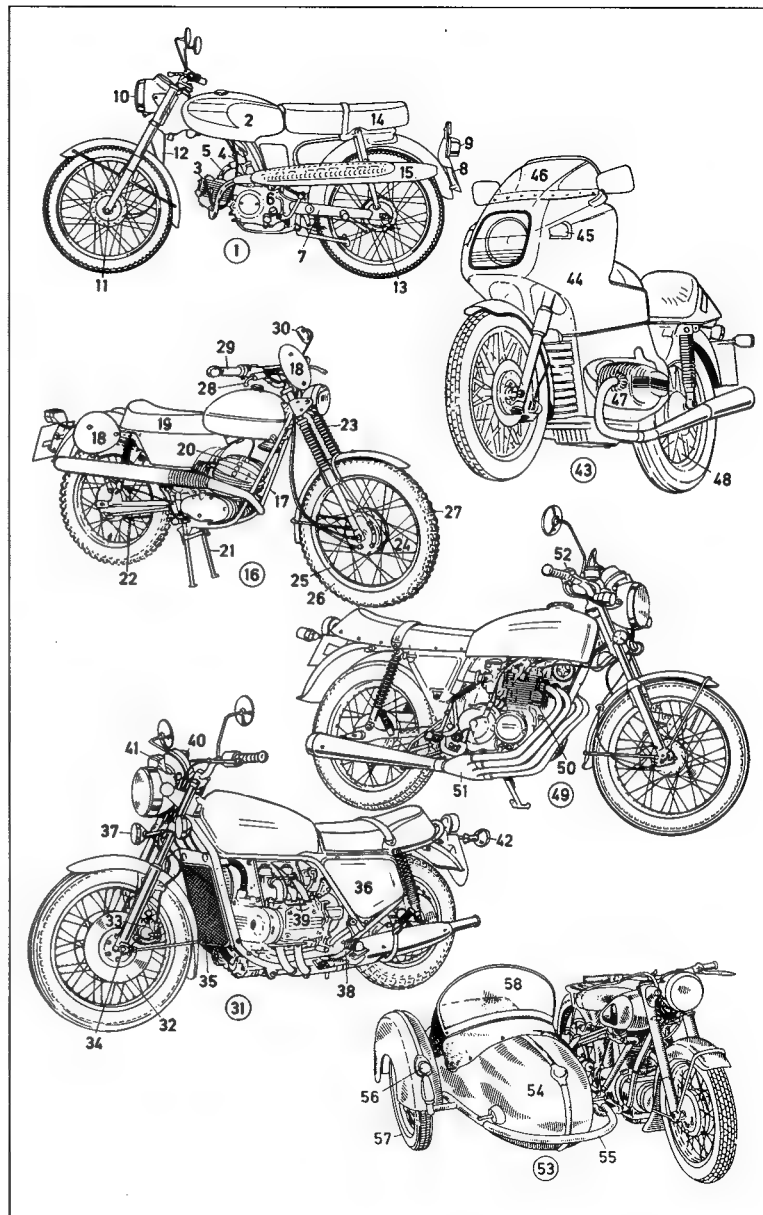

- 1 eight-cylinder V (vee) fuel-injection spark-ignition engine (Otto-cycle engine)
- 2 cross-section of spark-ignition engine (Otto-cycle internal combustion engine)
- 3 sectional view of five-cylinder in-line diesel engine
- 4 cross-section of diesel engine
- 5 two-rotor Wankel engine (rotary engine)
- 6 single-cylinder two-stroke internal combustion engine
- 7 fan
- 8 fan clutch for viscous drive
- 9 ignition distributor (distributor) with vacuum timing control
- 10 double roller chain
- 11 camshaft bearing
- 12 air-bleed duct
- 13 oil pipe for camshaft lubrication
- 14 camshaft, an overhead camshaft
- 15 venturi throat
- 16 intake silencer (absorption silencer, *Am.* absorption muffler)
- 17 fuel pressure regulator
- 18 inlet manifold
- 19 cylinder crankcase
- 20 flywheel
- 21 connecting rod (piston rod)
- 22 cover of crankshaft bearing
- 23 crankshaft
- 24 oil bleeder screw (oil drain plug)
- 25 roller chain of oil pump drive
- 26 vibration damper
- 27 distributor shaft for the ignition distributor (distributor)
- 28 oil filler neck
- 29 diaphragm spring
- 30 control linkage
- 31 fuel supply pipe (*Am.* fuel line)
- 32 fuel injector (injection nozzle)
- 33 rocker arm
- 34 rocker arm mounting
- 35 spark plug (sparking plug) with suppressor
- 36 exhaust manifold
- 37 piston with piston rings and oil scraper ring
- 38 engine mounting
- 39 dog flange (dog)

- 40 crankcase
- 41 oil sump (sump)
- 42 oil pump
- 43 oil filter
- 44 starter motor (starting motor)
- 45 cylinder head
- 46 exhaust valve
- 47 dipstick
- 48 cylinder head cover
- 49 double bushing chain
- 50 warm-up regulator
- 51 tapered needle for idling adjustment
- 52 fuel pressure pipe (fuel pressure line)
- 53 fuel leak line (drip fuel line)
- 54 injection nozzle (spray nozzle)
- 55 heater plug
- 56 thrust washer
- 57 intermediate gear shaft for the injection pump drive
- 58 injection timer unit
- 59 vacuum pump (low-pressure regulator)
- 60 cam for vacuum pump
- 61 water pump (coolant pump)
- 62 cooling water thermostat
- 63 thermo time switch
- 64 fuel hand pump
- 65 injection pump
- 66 glow plug
- 67 oil pressure limiting valve
- 68 rotor
- 69 seal
- 70 torque converter
- 71 single-plate clutch
- 72 multi-speed gearing (multi-step gearing)
- 73 port liners in the exhaust manifold for emission control
- 74 disc (disk) brake
- 75 differential gear (differential)
- 76 generator
- 77 foot gear-change control (foot gearshift control)
- 78 dry multi-plate clutch
- 79 cross-draught (*Am.* cross-draft) carburettor (*Am.* carburetor)
- 80 cooling ribs
- 81 V-belt (fan belt)

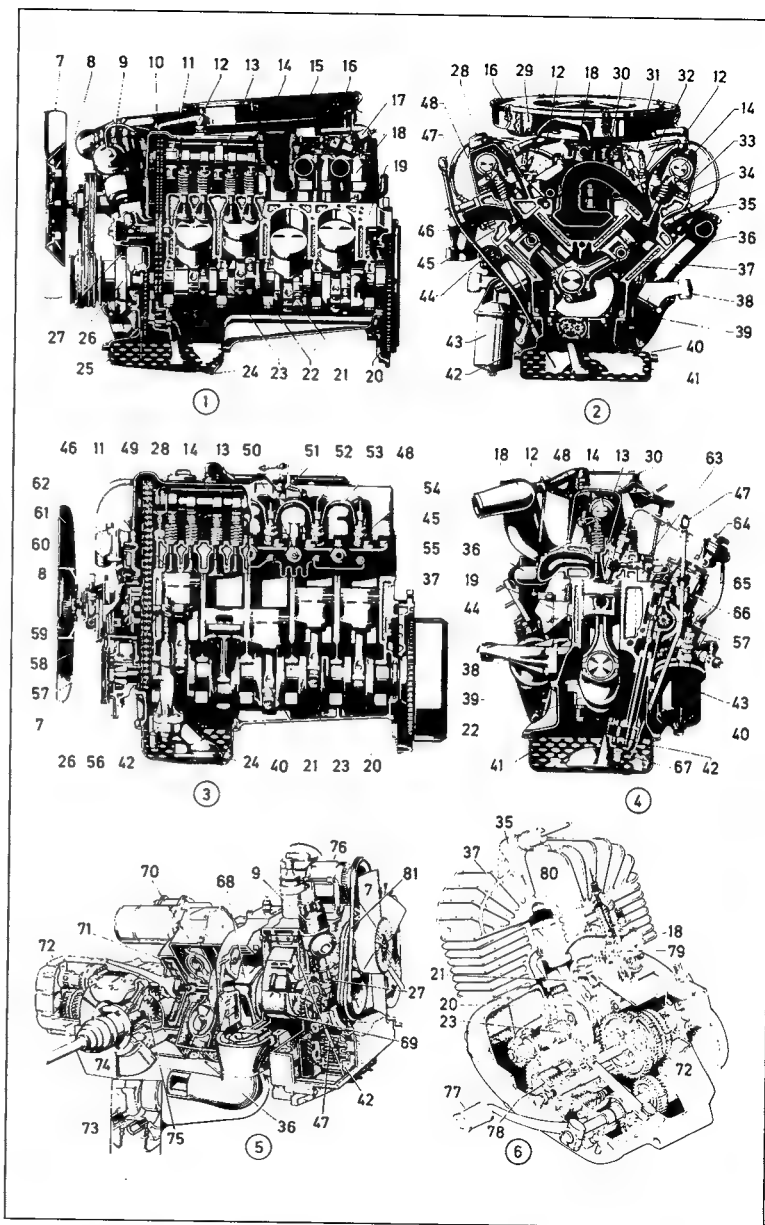

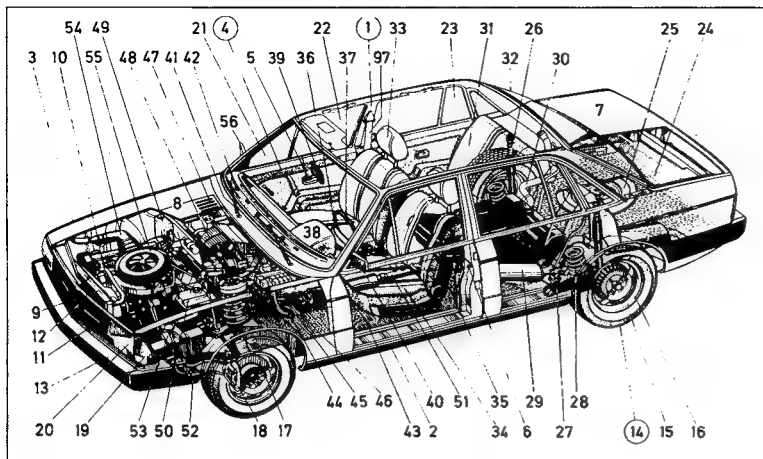

- | | |
|--|--|
| 1-56 motor car (car, Am. automobile, auto), a passenger vehicle | 24 boot (Am. trunk) |
| 1 monocoque body (unitary body) | 25 spare wheel |
| 2 chassis, the understructure of the body | 26 damper (shock absorber) |
| 3 front wing (Am. front fender) | 27 trailing arm |
| 4 car door | 28 coil spring |
| 5 door handle | 29 silencer (Am. muffler) |
| 6 door lock | 30 automatic ventilation system |
| 7 boot lid (Am. trunk lid) | 31 rear seats |
| 8 bonnet (Am. hood) | 32 rear window |
| 9 radiator | 33 adjustable headrest (head restraint) |
| 10 cooling water pipe | 34 driver's seat, a reclining seat |
| 11 radiator grill | 35 reclining backrest |
| 12 badging | 36 passenger seat |
| 13 rubber-covered front bumper (Am. front fender) | 37 steering wheel |
| 14 car wheel, a disc (disk) wheel | 38 centre (Am. center) console containing speedometer (coll. speedo), revolution counter (rev counter, tachometer), clock, fuel gauge (Am. gage), water temperature gauge, oil temperature gauge |
| 15 car tyre (Am. automobile tire) | 39 inside rear-view mirror |
| 16 rim (wheel rim) | 40 left-hand wing mirror |
| 17-18 disc (disk) brake | 41 windscreen wiper (Am. windshield wiper) |
| 17 brake disc (disk) (braking disc) | 42 defroster vents |
| 18 calliper (caliper) | 43 carpeting |
| 19 front indicator light (front turn indicator light) | 44 clutch pedal (coll. clutch) |
| 20 headlight (headlamp) with main beam (high beam), dipped beam (low beam), sidelight (side lamp, Am. sidemarker lamp) | 45 brake pedal (coll. brake) |
| 21 windscreen (Am. windshield), a panoramic windscreen | 46 accelerator pedal (coll. accelerator) |
| 22 crank-operated car window | 47 inlet vent |
| 23 quarter light (quarter vent) | 48 blower fan |
| | 49 brake fluid reservoir |

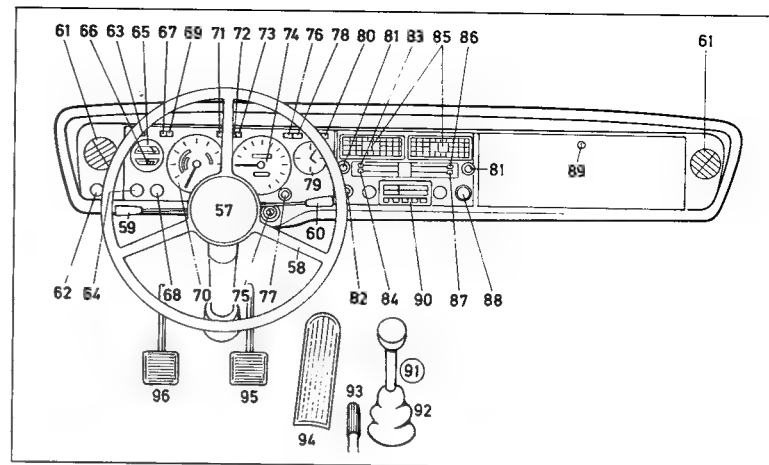

- | | |
|---|---|
| 50 battery | 76 warning lights for turn indicators and hazard flashers |
| 51 exhaust pipe | 77 switch for the courtesy light and reset button for the trip mileage recorder |
| 52 front running gear with front wheel drive | 78 ammeter |
| 53 engine mounting | 79 electric clock |
| 54 intake silencer (Am. intake muffler) | 80 warning light for heated rear window |
| 55 air filter (air cleaner) | 81 switch for the leg space ventilation |
| 56 right-hand wing mirror | 82 rear window heating switch |
| 57-90 dashboard (fascia panel) | 83 ventilation switch |
| 57 controlled-collapse steering column | 84 temperature regulator |
| 58 steering wheel spoke | 85 fresh-air inlet and control |
| 59 indicator and dimming switch | 86 fresh-air regulator |
| 60 wiper/washer switch and horn | 87 warm-air regulator |
| 61 side window blower | 88 cigar lighter |
| 62 sidelight, headlight, and parking light switch | 89 glove compartment (glove box) lock |
| 63 fog lamp warning light | 90 car radio |
| 64 fog headlamp and rear lamp switch | 91 gear lever (gearshift lever), a floor-type gear-change |
| 65 fuel gauge (Am. gage) | 92 leather gaiter |
| 66 water temperature gauge (Am. gage) | 93 hand brake lever |
| 67 warning light for rear fog lamp | 94 accelerator pedal |
| 68 hazard flasher switch | 95 brake pedal |
| 69 main beam warning light | 96 clutch pedal |
| 70 electric rev counter (revolution counter) | 97 seat belt (safety belt) |
| 71 fuel warning light | |
| 72 warning light for the hand brake and dual-circuit brake system | |
| 73 oil pressure warning light | |
| 74 speedometer (coll. speedo) with trip mileage recorder | |
| 75 starter and steering lock | |

- 1-15 carburettor** (*Am.* carburetor), a down-draught (*Am.* down-draft) carburettor
- 1 idling jet (slow-running jet)
 - 2 idling air jet (idle air bleed)
 - 3 air correction jet
 - 4 compensating airstream
 - 5 main airstream
 - 6 choke flap
 - 7 plunger
 - 8 venturi
 - 9 throttle valve (butterfly valve)
 - 10 emulsion tube
 - 11 idle mixture adjustment screw
 - 12 main jet
 - 13 fuel inlet (*Am.* gasoline inlet) (inlet manifold)
 - 14 float chamber
 - 15 float
- 16-27 pressure-feed lubricating system**
- 16 oil pump
 - 17 oil sump
 - 18 sump filter
 - 19 oil cooler
 - 20 oil filter
 - 21 main oil gallery (drilled gallery)
 - 22 crankshaft drilling (crankshaft tributary, crankshaft bleed)
 - 23 crankshaft bearing (main bearing)
 - 24 camshaft bearing
 - 25 connecting-rod bearing
 - 26 gudgeon pin (piston pin)
 - 27 bleed
- 28-47 four-speed synchromesh gearbox**
- 28 clutch pedal
 - 29 crankshaft
 - 30 drive shaft (propeller shaft)
 - 31 starting gear ring
 - 32 sliding sleeve for 3rd and 4th gear
 - 33 synchronizing cone
 - 34 helical gear wheel for 3rd gear
 - 35 sliding sleeve for 1st and 2nd gear
 - 36 helical gear wheel for 1st gear
 - 37 lay shaft
 - 38 speedometer drive
 - 39 helical gear wheel for speedometer drive
 - 40 main shaft
 - 41 gearshift rods
 - 42 selector fork for 1st and 2nd gear
 - 43 helical gear wheel for 2nd gear

- 44 selector head with reverse gear
 - 45 selector fork for 3rd and 4th gear
 - 46 gear lever (gearshift lever)
 - 47 gear-change pattern (gearshift pattern, shift pattern)
- 48-55 disc (disk) brake [assembly]**
- 48 brake disc (disk) (braking disc)
 - 49 calliper (caliper), a fixed calliper with friction pads
 - 50 servo cylinder (servo unit)
 - 51 brake shoes
 - 52 brake lining
 - 53 outlet to brake line
 - 54 wheel cylinder
 - 55 return spring
- 56-59 steering gear** (worm-and-nut steering gear)
- 56 steering column
 - 57 worm gear sector
 - 58 steering drop arm
 - 59 worm
- 60-64 water-controlled heater**
- 60 air intake
 - 61 heat exchanger (heater box)
 - 62 blower fan
 - 63 flap valve
 - 64 defroster vent
- 65-71 live axle** (rigid axle)
- 65 propeller shaft
 - 66 trailing arm
 - 67 rubber bush
 - 68 coil spring
 - 69 damper (shock absorber)
 - 70 Panhard rod
 - 71 stabilizer bar
- 72-84 MacPherson strut unit**
- 72 body-fixing plate
 - 73 upper bearing
 - 74 suspension spring
 - 75 piston rod
 - 76 suspension damper
 - 77 rim (wheel rim)
 - 78 stub axle
 - 79 steering arm
 - 80 track-rod ball-joint
 - 81 trailing link arm
 - 82 bump rubber (rubber bonding)
 - 83 lower bearing
 - 84 lower suspension arm

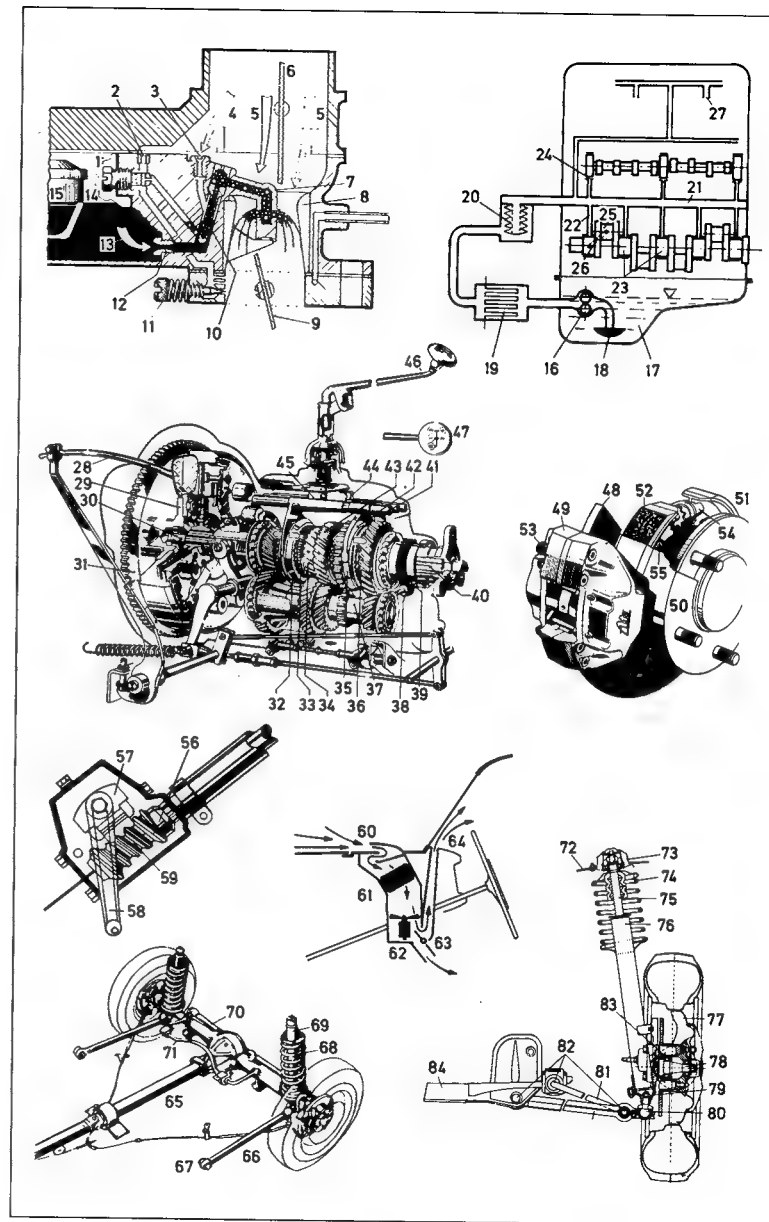

- 1-36 car models (Am. automobile models)
- 1 four-door touring saloon (Am. four-door sedan) in the upper-middle range
- 2 driver's door
- 3 rear door
- 4-10 four-door saloon (Am. four-door sedan) and four-door hatchback in the middle range
- 4 saloon (Am. sedan)
- 5 headrests (head restraints)
- 6 front seat
- 7 rear seat (back seat)
- 8 fastback saloon (Am. fastback sedan) (stubback saloon, Am. stubback sedan)
- 9 tailgate
- 10 fastback (stubback)
- 11 cross-country vehicle with all-wheel drive (four-wheel drive)
- 12 spare wheel
- 13 roll bar
- 14 cabriolet sports coupé (cabriolet sports car)
- 15 integral seat
- 16 automatic hood (Am. top) (power-operated hood, Am. top)
- 17 estate car (estate, shooting brake, Am. station wagon)
- 18 boot space (luggage compartment)
- 19 small three-door car
- 20 back (tailgate)
- 21 sill
- 22 folding back seat
- 23 boot (luggage compartment, Am. trunk)
- 24 (sliding) sunroof (steel sliding sunroof)
- 25 three-door hatchback
- 26 roadster (sports cabrio, sports cabriolet), a two-seater
- 27 hard top
- 28 sports coupé, a two-plus-two (two-seater with occasional seats)
- 29 fastback
- 30 occasional seat

- 31 low-profile tyre (Am. tire) (wide wheel)
- 32 gran turismo car (GT car)
- 33 integral bumper (Am. integral fender)
- 34 rear spoiler
- 35 back
- 36 front spoiler

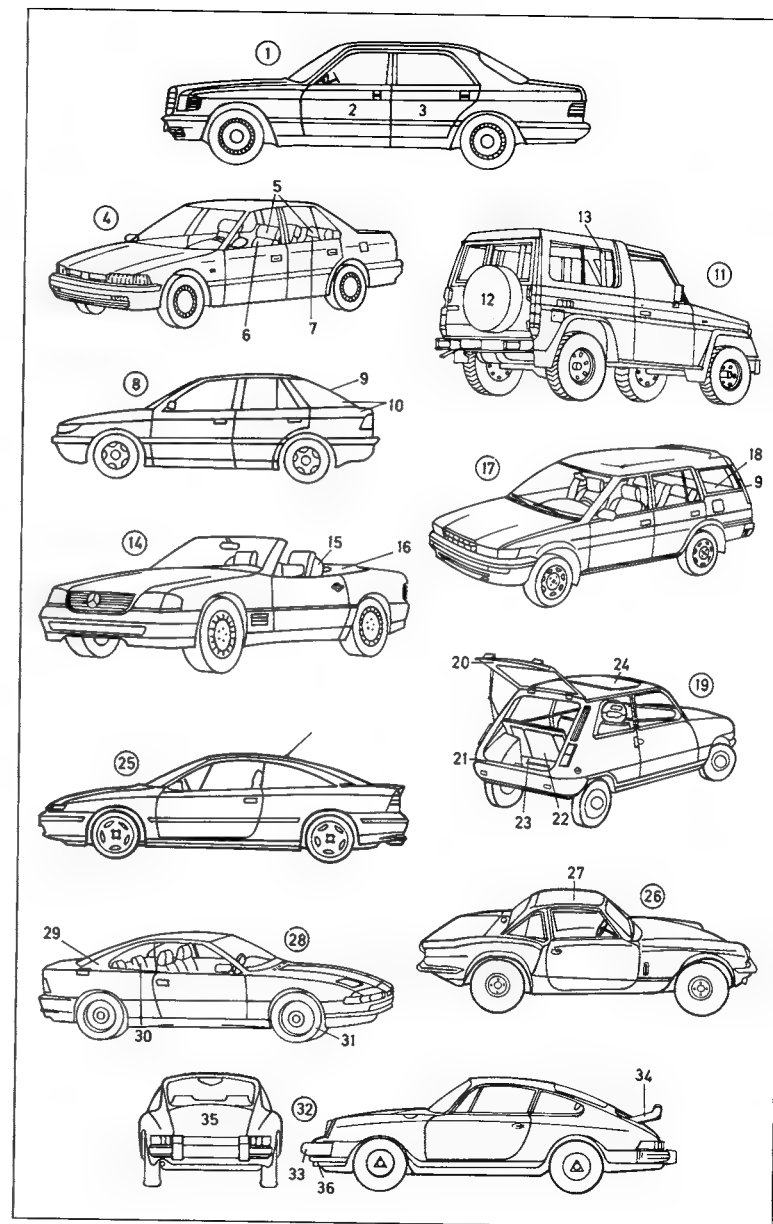

- 1 light cross-country lorry (light truck, pick-up truck) with all-wheel drive (four-wheel drive)
- 2 cab (driver's cab)
- 3 loading platform (body)
- 4 spare tyre (Am. spare tire), a cross-country tyre
- 5 light lorry (light truck, pick-up truck)
- 6 platform truck
- 7 medium van
- 8 sliding side door [for loading and unloading]
- 9 minibus
- 10 folding top (sliding roof)
- 11 rear door
- 12 hinged side door
- 13 luggage compartment
- 14 passenger seat
- 15 cab (driver's cab)
- 16 air inlet
- 17 motor coach (coach, bus)
- 18 luggage locker
- 19 hand luggage (suitcase, case)
- 20 heavy lorry (heavy truck, heavy motor truck)
- 21 tractive unit (tractor, towing vehicle)
- 22 trailer (drawbar trailer)
- 23 swop platform (body)
- 24 three-way tipper (three-way dump truck)
- 25 tipping body (dump body)
- 26 hydraulic cylinder
- 27 supported container platform
- 28 articulated vehicle, a vehicle tanker
- 29 tractive unit (tractor, towing vehicle)
- 30-33 semi-trailer (skeletal)
- 30 tank
- 31 turntable
- 32 undercarriage
- 33 spare wheel
- 34 midi bus [for short-route town operations]
- 35 outward-opening doors
- 36 double-deck bus (double-decker bus)

- 37 lower deck (lower saloon)
- 38 upper deck (upper saloon)
- 39 boarding platform
- 40 trolley bus
- 41 current collector
- 42 trolley (trolley shoe)
- 43 overhead wires
- 44 trolley bus trailer
- 45 pneumatically sprung rubber connection

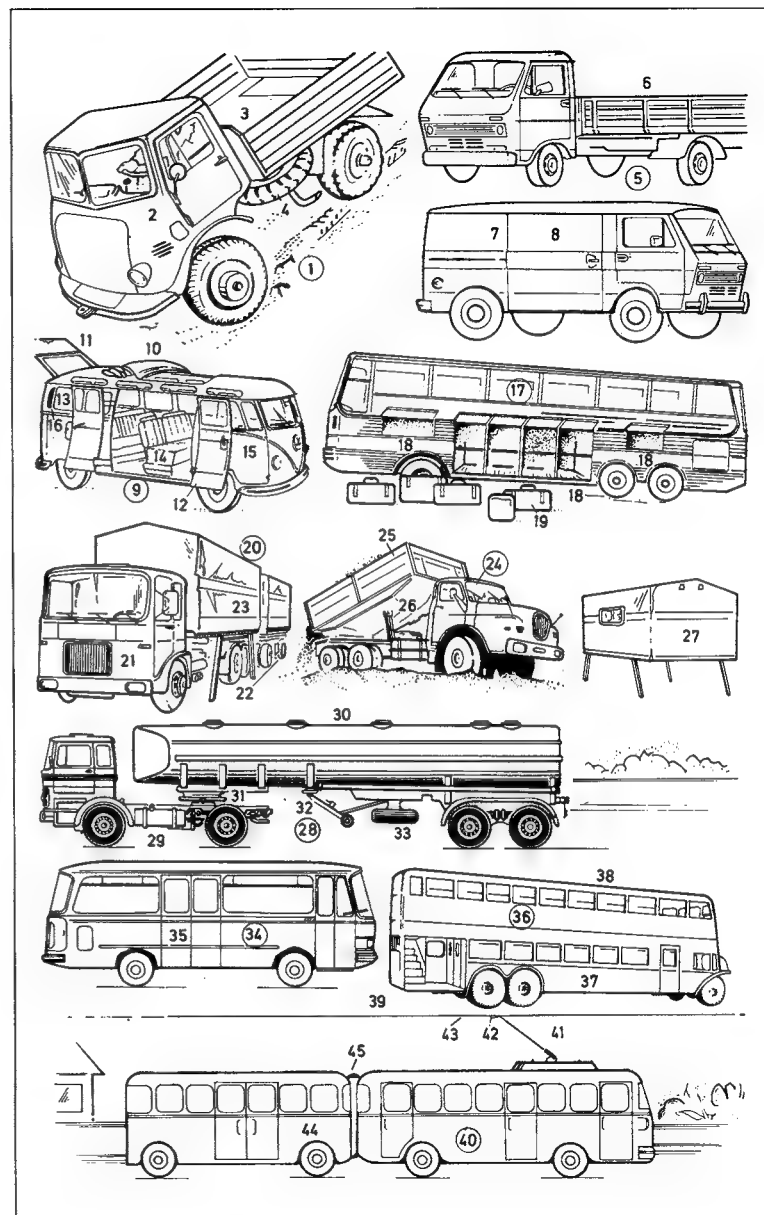

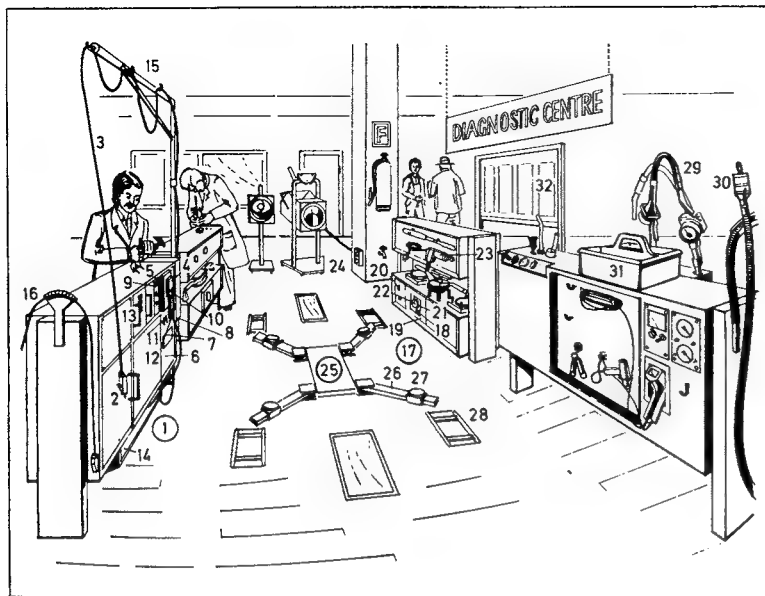

- | | |
|---|--|
| 1-55 agent's garage (distributor's garage, <i>Am.</i> specialty shop) | 18 right-hand optic plate |
| 1-23 diagnostic test bay | 19 actuating transistors |
| 1 computer | 20 projector switch |
| 2 main computer socket | 21 check light for wheel alignment, a row of photocells |
| 3 computer harness (computer cable) | 22 check light for steering alignment, a row of photocells |
| 4 switch from automatic to manual | 23 power screwdriver |
| 5 slot for program cards | 24 beam setter |
| 6 printout machine (printer) | 25 hydraulic lift |
| 7 condition report (data printout) | 26 adjustable arm of hydraulic lift |
| 8 master selector (hand control) | 27 hydraulic lift pad |
| 9 light read-out [green: OK; red: not OK] | 28 excavation |
| 10 rack for program cards | 29 pressure gauge (<i>Am.</i> gage) |
| 11 mains button | 30 grease gun |
| 12 switch for fast readout | 31 storage box for small parts |
| 13 firing sequence insert | 32 wall chart [of spare parts] |
| 14 shelf for used cards | |
| 15 cable boom | |
| 16 oil temperature sensor | |
| 17 test equipment for wheel and steering alignment | |

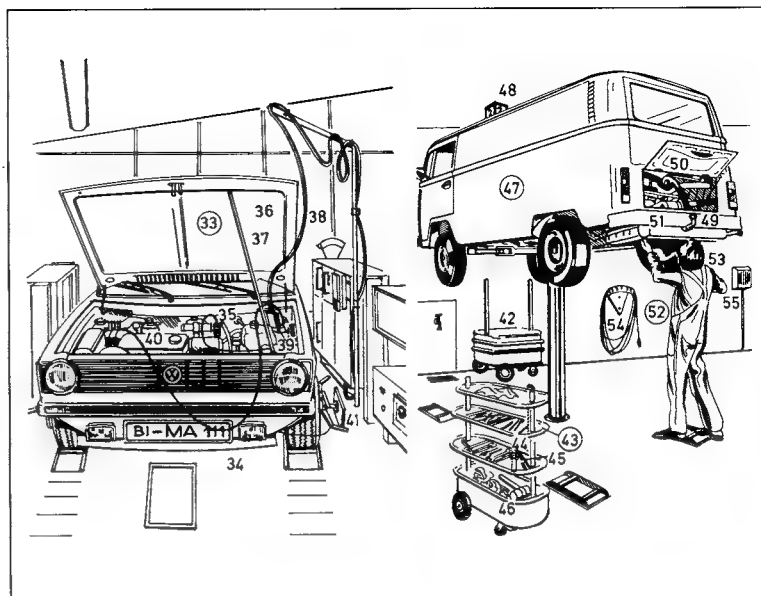

- | | |
|--|--|
| 33 automatic computer test | 48 car location number |
| 34 motor car (car, <i>Am.</i> automobile, auto), a passenger vehicle | 49 rear engine |
| 35 engine compartment | 50 tailgate |
| 36 bonnet (<i>Am.</i> hood) | 51 exhaust system |
| 37 bonnet support (<i>Am.</i> hood support) | 52 exhaust repair |
| 38 computer harness (computer cable) | 53 motor car mechanic (motor vehicle mechanic, <i>Am.</i> automotive mechanic) |
| 39 main computer socket | 54 air hose |
| 40 oil temperature sensor | 55 intercom |
| 41 wheel mirror for visual wheel and steering alignment | |
| 42 tool trolley | |
| 43 tools | |
| 44 impact wrench | |
| 45 torque wrench | |
| 46 body hammer (roughing-out hammer) | |
| 47 vehicle under repair, a minibus | |

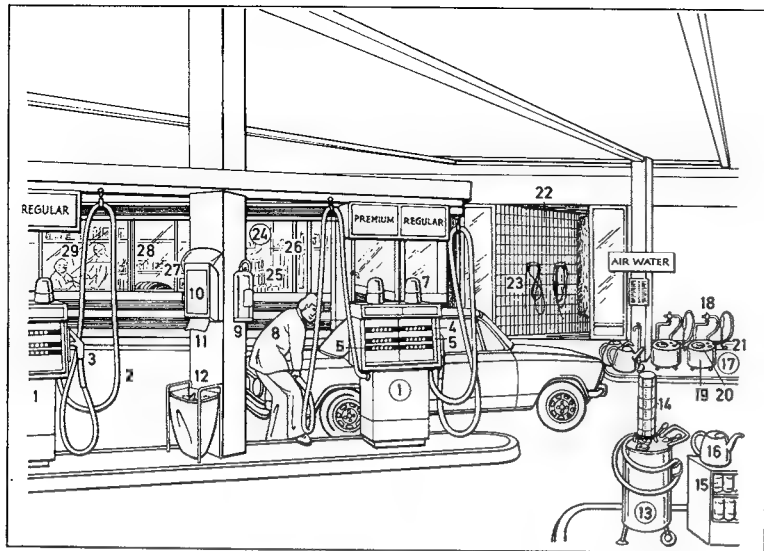

- 1-29 service station (petrol station, filling station, *Am.* gasoline station, gas station), a self-service station
- 1 petrol (*Am.* gasoline) pump (blending pump) for unleaded (lead-free) premium grade and regular petrol (*Am.* gasoline) (*sim.*: for derv)
- 2 hose (petrol pump, *Am.* gasoline pump, hose)
- 3 nozzle
- 4 cash readout
- 5 volume readout
- 6 price display
- 7 indicator light
- 8 driver using self-service petrol pump (*Am.* gasoline pump)
- 9 fire extinguisher
- 10 paper-towel dispenser
- 11 paper towel
- 12 litter receptacle
- 13 two-stroke blending pump
- 14 meter
- 15 engine oil
- 16 oil can
- 17 tyre pressure gauge (*Am.* tire pressure gage)
- 18 air hose
- 19 static air tank
- 20 pressure gauge (*Am.* gage) (manometer)
- 21 air filler neck
- 22 repair bay (repair shop)
- 23 car-wash hose, a hose (hosepipe)
- 24 accessory shop
- 25 petrol can (*Am.* gasoline can)
- 26 rain cape
- 27 car tyres (*Am.* automobile tires)
- 28 car accessories
- 29 cash desk (console)

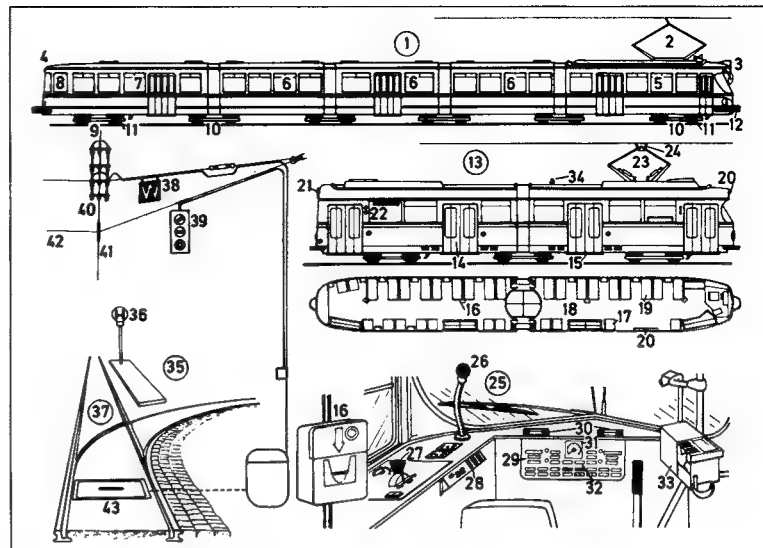

- 1 twelve-axle articulated railcar for interurban rail service
- 2 current collector
- 3 head of the railcar
- 4 rear of the railcar
- 5 carriage A containing the motor
- 6 carriage B (*also*: carriages C and D)
- 7 carriage E containing the motor
- 8 rear controller
- 9 driving bogie
- 10 carrying bogie
- 11 wheel guard
- 12 bumper (*Am.* fender)
- 13 six-axle articulated railcar ('Mannheim' type) for tram (*Am.* streetcar, trolley) and urban rail services
- 14 entrance and exit door, a double folding door
- 15 step
- 16 ticket-cancelling machine
- 17 single seat
- 18 standing room portion
- 19 double seat
- 20 route (number) and destination sign
- 21 route sign (number sign)
- 22 indicator (indicator light)
- 23 pantograph (current collector)
- 24 carbon or aluminium (*Am.* aluminum) alloy trolley shoes
- 25 driver's position
- 26 microphone
- 27 controller
- 28 radio equipment (radio communication set)
- 29 dashboard
- 30 dashboard lighting
- 31 speedometer
- 32 buttons controlling doors, windscreen wipers, internal and external lighting
- 33 ticket counter with change machine
- 34 radio antenna
- 35 tram stop (*Am.* streetcar stop, trolley stop)
- 36 tram stop sign (*Am.* streetcar stop sign, trolley stop sign)
- 37 electric change points
- 38 points signal (switch signal)
- 39 points change indicator
- 40 trolley wire contact point
- 41 trolley wire (overhead contact wire)
- 42 overhead cross wire
- 43 electric (*also*: electrohydraulic, electromechanical) points mechanism

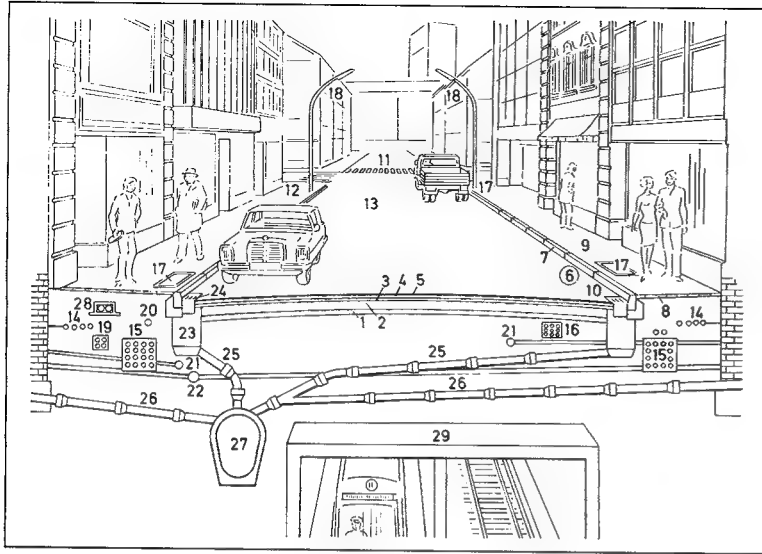

- | | |
|---|---|
| 1-5 road layers | 20 subscribers' (Am. customers') tele-
phone lines |
| 1 anti-frost layer | 21 gas main |
| 2 bituminous sub-base course | 22 water main |
| 3 base course | 23 drain |
| 4 binder course | 24 drain cover |
| 5 bituminous surface | 25 drain pipe |
| 6 kerb (curb) | 26 waste pipe |
| 7 kerbstone (curbstone) | 27 combined sewer |
| 8 paving (pavement) | 28 district heating main |
| 9 pavement (Am. sidewalk, walk-
way) | 29 underground tunnel |
| 10 gutter | |
| 11 pedestrian crossing (zebra cross-
ing, Am. crosswalk) | |
| 12 street corner | |
| 13 street | |
| 14 electricity cables | |
| 15 telephone cables | |
| 16 telephone cable pipeline | |
| 17 cable manhole with cover (with
manhole cover) | |
| 18 lamp post with lamp | |
| 19 electricity cables for technical
installations | |

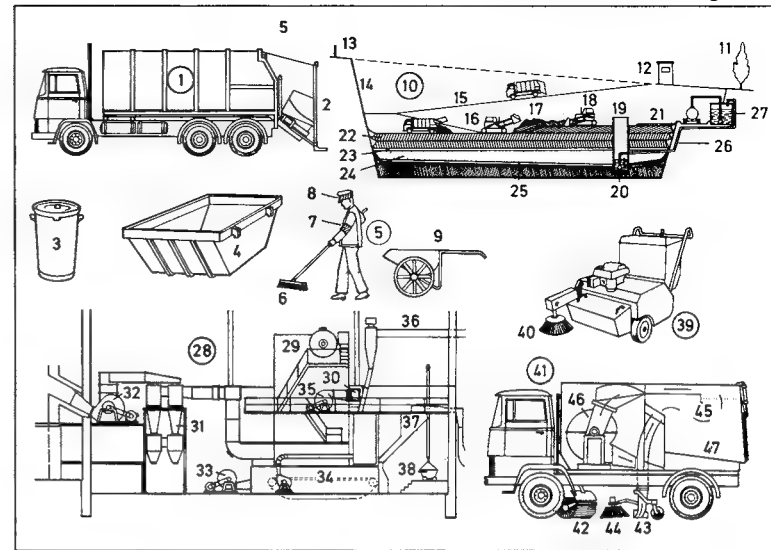

- | | |
|--|---|
| 1 refuse collection vehicle (Am. garbage
truck) | 24 morainic filter layer |
| 2 dustbin-tipping device (Am. garbage
can dumping device), a dust-free empty-
ing system | 25 drainage layer |
| 3 dustbin (Am. garbage can, trash can) | 26 drain pipe |
| 4 refuse container (Am. garbage container) | 27 water tank |
| 5 road sweeper (Am. street sweeper) | 28 refuse (Am. garbage) incineration unit |
| 6 broom | 29 furnace |
| 7 fluorescent armband | 30 oil-firing system |
| 8 cap with fluorescent band | 31 separation plant |
| 9 road sweeper's (Am. street sweeper's)
barrow | 32 extraction fan |
| 10 controlled tip (Am. sanitary landfill,
sanitary fill) | 33 low-pressure fan for the grate |
| 11 screen | 34 continuous feed grate |
| 12 weigh office | 35 fan for the oil-firing system |
| 13 fence | 36 conveyor for separately incinerated
material |
| 14 embankment | 37 coal feed conveyor |
| 15 access ramp | 38 truck for carrying fuller's earth |
| 16 bulldozer | 39 mechanical sweeper |
| 17 refuse (Am. garbage) | 40 circular broom |
| 18 bulldozer for dumping and compacting | 41 road-sweeping lorry (street-cleaning
lorry, street cleaner) |
| 19 pump shaft | 42 cylinder broom |
| 20 waste water pump | 43 suction port |
| 21 porous cover | 44 feeder broom |
| 22 compacted and decomposed refuse | 45 air flow |
| 23 gravel filter layer | 46 fan |
| | 47 dust collector |

1-54 road-building machinery

- 1 shovel (power shovel, excavator)
- 2 machine housing
- 3 caterpillar mounting (*Am.* caterpillar tractor)
- 4 digging bucket arm (dipper stick)
- 5 digging bucket (bucket)
- 6 digging bucket (bucket) teeth
- 7 tipper (dump truck), a heavy lorry (*Am.* truck)
- 8 tipping body (*Am.* dump body)
- 9 reinforcing rib
- 10 extended front
- 11 cab (driver's cab)
- 12 bulk material
- 13 concrete scraper, an aggregate scraper
- 14 skip hoist
- 15 mixing drum (mixer drum), a mixing machine
- 16 caterpillar hauling scraper
- 17 scraper blade
- 18 levelling (*Am.* leveling) blade (smoothing blade)
- 19 grader (motor grader)
- 20 scarifier (ripper, road ripper, rooter)
- 21 grader levelling (*Am.* leveling) blade (grader ploughshare, *Am.* plowshare)
- 22 blade-slewing gear (slew turntable)
- 23 light railway (narrow-gauge, *Am.* narrow-gage, railway)
- 24 light railway (narrow-gauge, *Am.* narrow-gage) diesel locomotive
- 25 trailer wagon (wagon truck, skip)
- 26 tamper (rammer) *heavier*: frog
- 27 guide rods
- 28 bulldozer
- 29 bulldozer blade
- 30 pushing frame
- 31 road-metal spreading machine (macadam spreader, stone spreader)
- 32 tamping beam
- 33 sole-plate
- 34 side stop
- 35 side of storage bin

- 36 three-wheeled roller, a road roller
- 37 roller
- 38 all-weather roof
- 39 mobile diesel-powered air compressor
- 40 oxygen cylinder
- 41 self-propelled gritter
- 42 spreading flap
- 43 surface finisher
- 44 side stop
- 45 bin
- 46 tar-spraying machine (bituminous distributor) with tar and bitumen heater
- 47 tar storage tank
- 48 fully automatic asphalt drying and mixing plant
- 49 bucket elevator (elevating conveyer)
- 50 asphalt-mixing drum (asphalt mixer drum)
- 51 filler hoist
- 52 filler opening
- 53 binder injector
- 54 mixed asphalt outlet
- 55 typical cross-section of a bituminous road
- 56 grass verge
- 57 crossfall
- 58 asphalt surface (bituminous layer, bituminous coating)
- 59 base (base course)
- 60 hardcore sub-base course (Telford base) or gravel sub-base course, an anti-frost layer
- 61 sub-drainage
- 62 perforated cement pipe
- 63 drainage ditch
- 64 soil covering

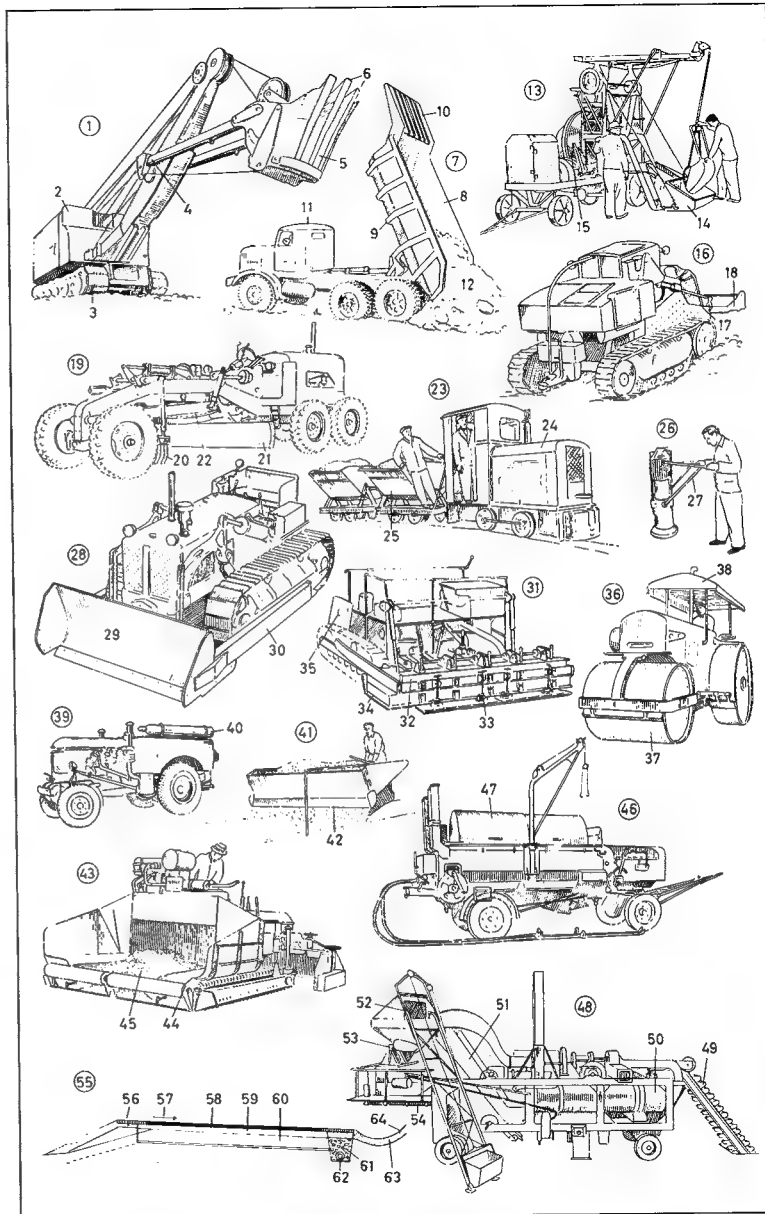

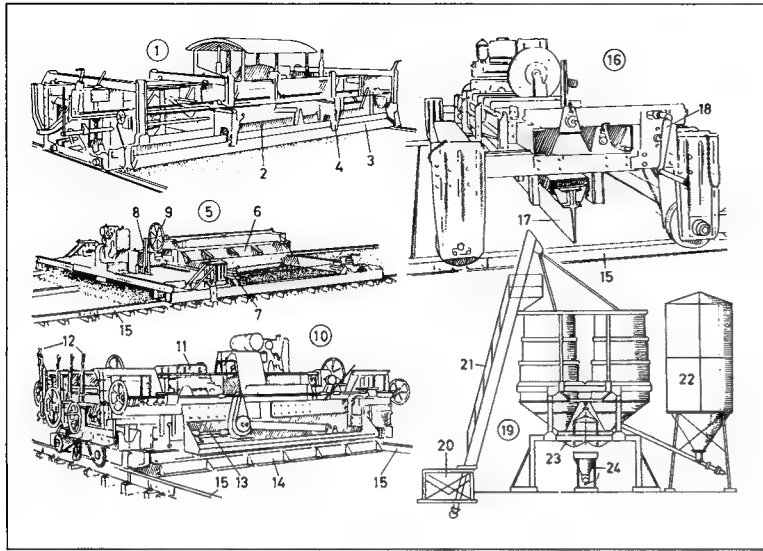

1-24 concrete road construction
(highway construction)

- 1 subgrade grader
- 2 tamping beam (consolidating beam)
- 3 levelling (*Am.* leveling) beam
- 4 roller guides for the levelling (*Am.* leveling) beam
- 5 concrete spreader
- 6 concrete spreader box
- 7 cable guides
- 8 control levers
- 9 handwheel for emptying the boxes
- 10 concrete-vibrating compactor
- 11 gearing (gears)
- 12 control levers (operating levers)
- 13 axle drive shaft to vibrators (tamper) of vibrating beam
- 14 screeding board (screeding beam)
- 15 road form
- 16 joint cutter
- 17 joint-cutting blade
- 18 crank for propelling machine

- 19 concrete-mixing plant, a stationary central mixing plant, an automatic batching and mixing plant
- 20 collecting bin
- 21 bucket elevator
- 22 cement store
- 23 concrete mixer
- 24 concrete pump hopper

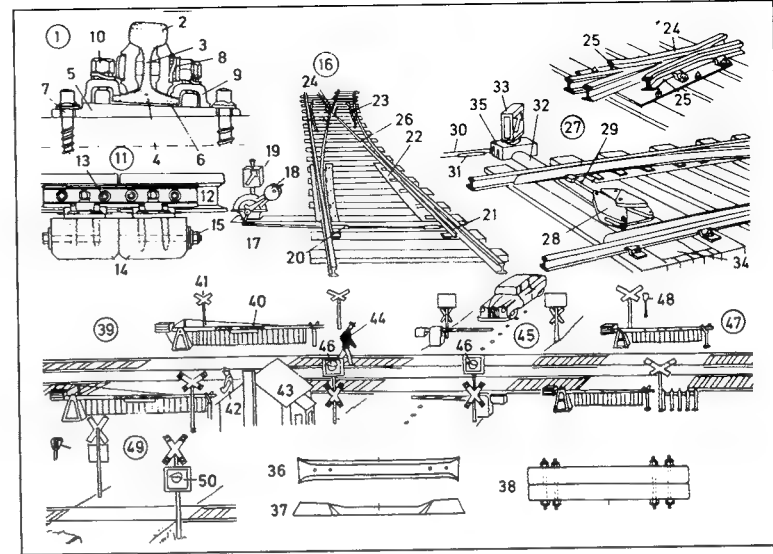

1-38 line (track)

- 1 rail
- 2 rail head
- 3 web (rail web)
- 4 rail foot (rail bottom)
- 5 sole-plate (base plate)
- 6 cushion
- 7 coach screw (coach bolt)
- 8 lock washers (spring washers)
- 9 rail clip (clip)
- 10 T-head bolt
- 11 rail joint (joint)
- 12 fishplate
- 13 fishbolt
- 14 coupled sleeper (*Am.* coupled tie, coupled crosstie)
- 15 coupling bolt
- 16 manually-operated points (manually-operated switch)
- 17 switch stand
- 18 weight
- 19 points signal (switch signal, points signal lamp, switch signal lamp)
- 20 pull rod
- 21 switch blade (switch tongue)
- 22 slide chair
- 23 check rail (guard rail)
- 24 frog
- 25 wing rail
- 26 closure rail
- 27 remote-controlled points (remote-controlled switch)

- 28 point lock (switch lock)
- 29 stretcher bar
- 30 point wire
- 31 turnbuckle
- 32 channel
- 33 electrically illuminated points signal (switch signal)
- 34 trough
- 35 points motor with protective casing
- 36 steel sleeper (*Am.* steel tie, steel crosstie)
- 37 concrete sleeper (*Am.* concrete tie, concrete crosstie)
- 38 coupled sleeper (*Am.* coupled tie, coupled crosstie)
- 39-50 level crossings (*Am.* grade crossings)
- 39 protected level crossing (*Am.* protected grade crossing)
- 40 barrier (gate)
- 41 warning cross (*Am.* crossbuck)
- 42 crossing keeper (*Am.* gateman)
- 43 crossing keeper's box (*Am.* gateman's box)
- 44 linesman (*Am.* trackwalker)
- 45 half-barrier crossing
- 46 warning light
- 47 intercom-controlled crossing; *sim.*: telephone-controlled crossing
- 48 intercom system
- 49 unprotected level crossing (*Am.* unprotected grade crossing)
- 50 warning light

(Signalling Equipment)

- 1-6 stop signals (main signals)
- 1 stop signal (main signal), a semaphore signal in 'stop' position
- 2 signal arm (semaphore arm)
- 3 electric stop signal (colour light, Am. color light, signal) at 'stop'
- 4 signal position: 'proceed at low speed'
- 5 signal position: 'proceed'
- 6 substitute signal
- 7-24 distant signals
- 7 semaphore signal at 'be prepared to stop at next signal'
- 8 supplementary semaphore arm
- 9 colour light (Am. color light) distant signal at 'be prepared to stop at next signal'
- 10 signal position: 'be prepared to proceed at low speed'
- 11 signal position: 'proceed main signal ahead'
- 12 semaphore signal with indicator plate showing a reduction in braking distance of more than 5%
- 13 triangle (triangle sign)
- 14 colour light (Am. color light) distant signal with indicator light for showing reduced braking distance
- 15 supplementary white light
- 16 distant signal indicating 'be prepared to stop at next signal' (yellow light)
- 17 second distant signal (distant signal with supplementary light, without indicator plate)
- 18 distant signal with speed indicator
- 19 distant speed indicator
- 20 distant signal with route indicator
- 21 route indicator
- 22 distant signal without supplementary arm in position: 'be prepared to stop at next signal'
- 23 distant signal without supplementary arm in 'be prepared to proceed' position
- 24 distant signal identification plate
- 25-44 supplementary signals
- 25 stop board for indicating the stopping point at a control point
- 26-29 approach signs
- 26 approach sign 100 m from distant signal
- 27 approach sign 175 m from distant signal
- 28 approach sign 250 m from distant signal
- 29 approach sign at a distance of 5% less than the braking distance on the section
- 30 chequered sign indicating stop signals (main signals) not positioned immediately to the right of or over the line (track)
- 31, 32 stop boards to indicate the stopping point of the front of the train

- 33 stop board indicating 'be prepared to stop'
- 34, 35 snow plough (Am. snowplow) signs
- 34 'raise snow plough (Am. snowplow)' sign
- 35 'lower snow plough (Am. snowplow)' sign
- 36-44 speed restriction signs
- 36-38 speed restriction sign [maximum speed $3 \times 10 = 30$ kph]
- 36 sign for day running
- 37 speed code number
- 38 illuminated sign for night running
- 39 commencement of temporary speed restriction
- 40 termination of temporary speed restriction
- 41 speed restriction sign for a section with a permanent speed restriction [maximum speed $5 \times 10 = 50$ kph]
- 42 commencement of permanent speed restriction
- 43 speed restriction warning sign [only on main lines]
- 44 speed restriction sign [only on main lines]
- 45-52 point signals (switch signals)
- 45-48 single points (single switches)
- 45 route straight ahead (main line)
- 46 [right] branch
- 47 [left] branch
- 48 branch [seen from the frog]
- 49-52 double crossover
- 49 route straight ahead from left to right
- 50 route straight ahead from right to left
- 51 turnout to the left from the left
- 52 turnout to the right from the right
- 53 manually-operated signal box (Am. signal tower, switch tower)
- 54 lever mechanism
- 55 points lever (switch lever) [blue], a lock lever
- 56 signal lever [red]
- 57 catch
- 58 route lever
- 59 block instruments
- 60 block section panel
- 61 electrically-operated signal box (Am. signal tower, switch tower)
- 62 points (switch) and signal knobs
- 63 lock indicator panel
- 64 track and signal indicator
- 65 track diagram control layout
- 66 track diagram control panel (domino panel)
- 67 push buttons
- 68 routes
- 69 intercom system

(Signalling Equipment)

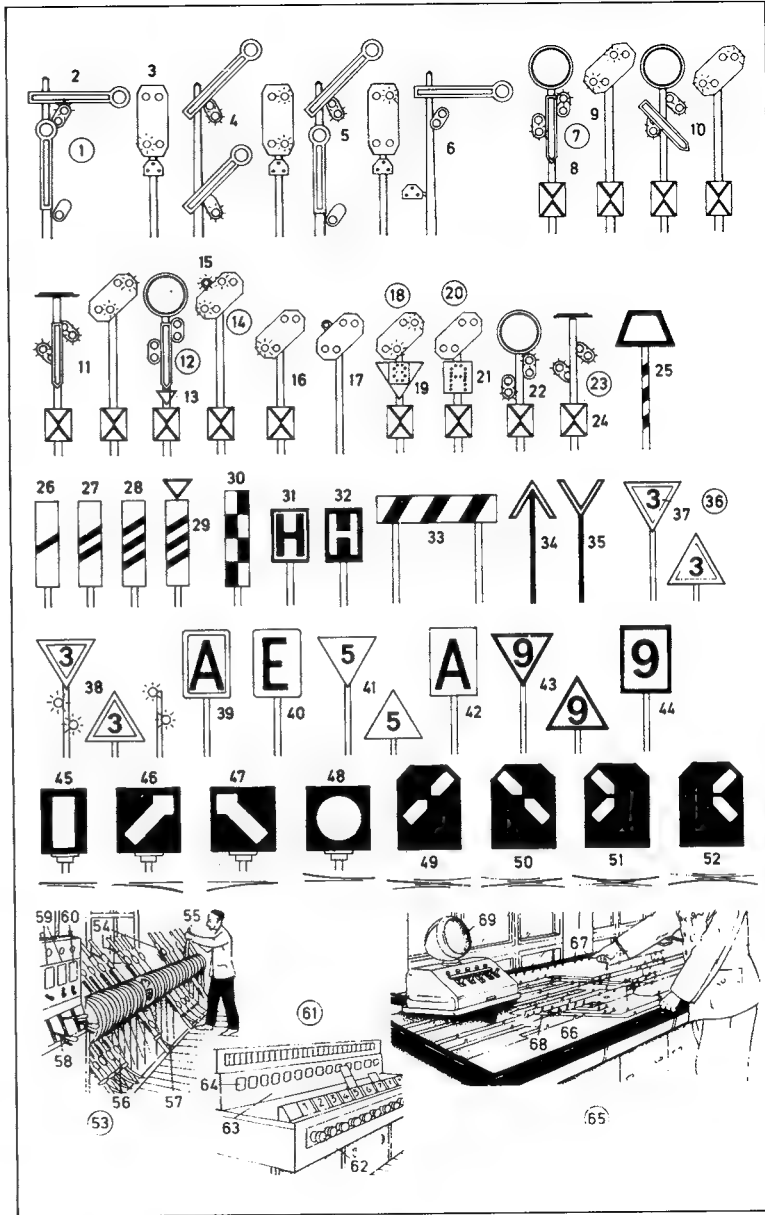

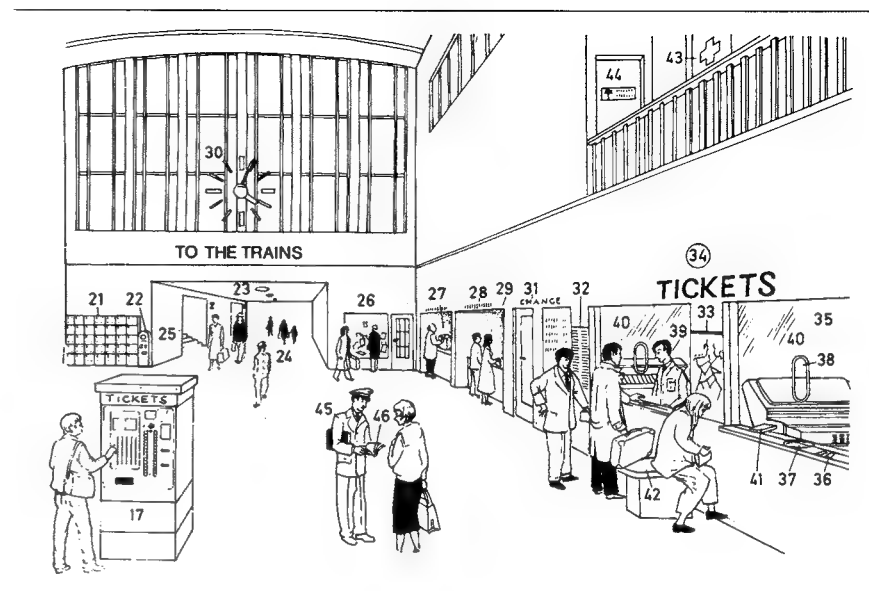
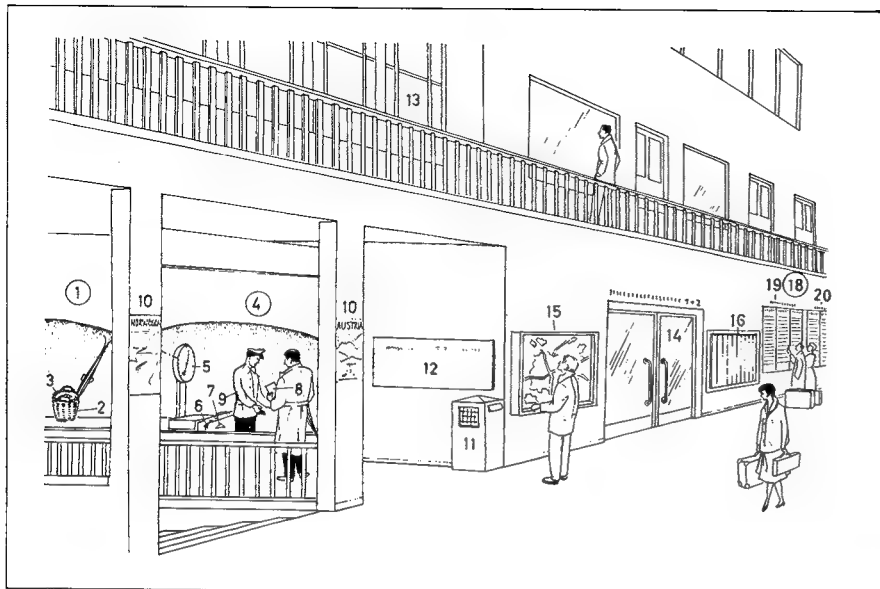

- 1 parcels office
- 2 parcels
- 3 basket [with lock]
- 4 luggage counter
- 5 platform scale with dial
- 6 suitcase (case)
- 7 luggage sticker
- 8 luggage receipt
- 9 luggage clerk
- 10 poster (advertisement)
- 11 station post box (*Am.* station mailbox)
- 12 station guide
- 13 station restaurant
- 14 waiting room
- 15 map of the town (street map)
- 16 timetable (*Am.* schedule)
- 17 ticket machine
- 18 arrivals and departures board (timetable)
- 19 arrival timetable (*Am.* arrival schedule)
- 20 departure timetable (*Am.* departure schedule)

- 21 left luggage lockers
- 22 change machine
- 23 tunnel to the platforms
- 24 passengers
- 25 steps to the platforms
- 26 station bookstall (*Am.* station bookstand)
- 27 left luggage office (left luggage)
- 28 travel centre (*Am.* center); also: accommodation bureau
- 29 information office (*Am.* information bureau)
- 30 station clock
- 31 bank branch with foreign exchange counter
- 32 indicator board showing exchange rates
- 33 railway map (*Am.* railroad map)
- 34 ticket office
- 35 ticket counter
- 36 ticket
- 37 revolving tray
- 38 grill

- 39 ticket clerk (*Am.* ticket agent)
- 40 pane of glass (window)
- 41 pocket timetable (*Am.* pocket train schedule)
- 42 luggage rest
- 43 first aid station
- 44 Travellers' (*Am.* Travelers') Aid
- 45 railway (*Am.* railroad) information clerk
- 46 official timetable (official railway guide, *Am.* train schedule)

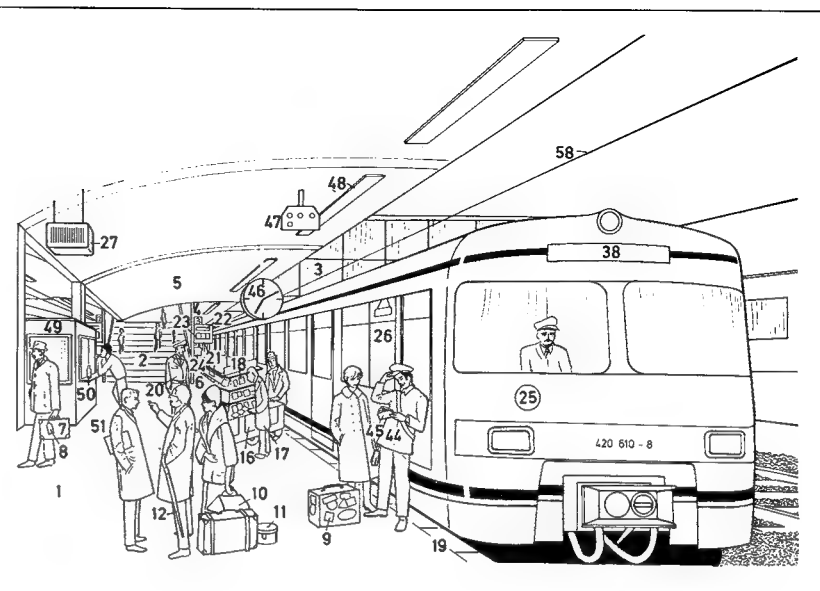
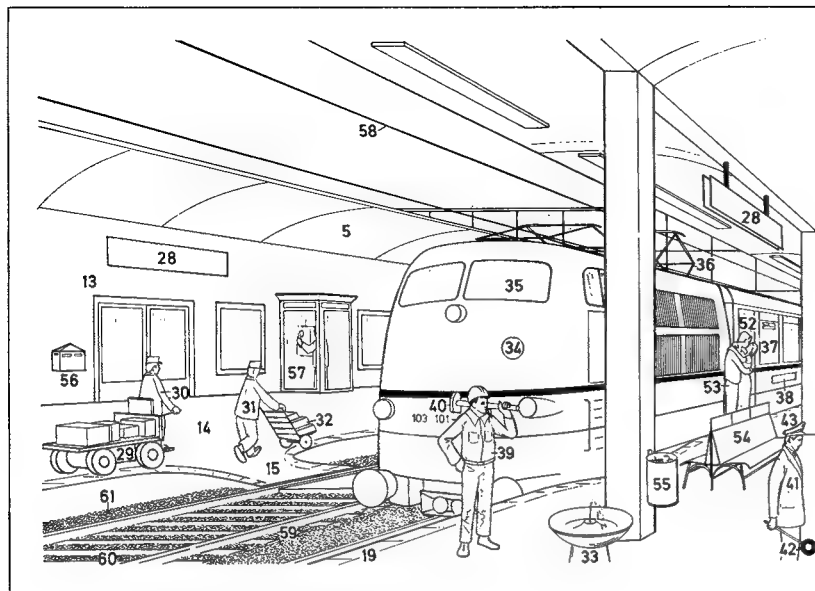

- | | | |
|---|---|---|
| 1 platform | 22 destination indicator | 43 red cap |
| 2 steps to the platform | 23 departure time indicator | 44 inspector |
| 3 bridge | 24 delay indicator | 45 pocket timetable (<i>Am.</i> pocket train schedule) |
| 4 platform number | 25 suburban train, a railcar | 46 platform clock |
| 5 platform roofing | 26 special compartment | 47 starting signal |
| 6 passengers | 27 platform loudspeaker | 48 platform lighting |
| 7-12 luggage | 28 station sign | 49 refreshment kiosk |
| 7 suitcase (case) | 29 electric trolley (electric truck) | 50 beer bottle |
| 8 luggage label | 30 loading foreman | 51 newspaper |
| 9 hotel sticker | 31 porter (<i>Am.</i> redcap) | 52 parting kiss |
| 10 travelling (<i>Am.</i> traveling) bag | 32 barrow | 53 embrace |
| 11 hat box | 33 drinking fountain | 54 platform seat |
| 12 umbrella, a walking-stick umbrella | 34 electric Eurocity express; <i>also:</i> IC express (<i>Intercity</i> express) | 55 litter bin (<i>Am.</i> trash bin) |
| 13 offices | 35 electric locomotive, an express locomotive | 56 platform post box (<i>Am.</i> platform mailbox) |
| 14 platform | 36 collector bow (sliding bow) | 57 platform telephone |
| 15 crossing | 37 secretarial compartment | 58 trolley wire (overhead contact wire) |
| 16 news trolley | 38 destination board | 59-61 track |
| 17 news vendor (<i>Am.</i> news dealer) | 39 wheel tapper | 59 rail |
| 18 reading matter for the journey | 40 wheel-tapping hammer | 60 sleeper (<i>Am.</i> tie, crosstie) |
| 19 edge of the platform | 41 station foreman | 61 ballast (bed) |
| 20 railway policeman (<i>Am.</i> railroad policeman) | 42 signal | |
| 21 destination board | | |

- 1 ramp (vehicle ramp); *sim.*: livestock ramp
- 2 electric truck
- 3 trailer
- 4 part loads (*Am.* package freight, less-than-carload freight); *in general traffic*: general goods in general consignments (in mixed consignments)
- 5 crate
- 6 goods van (*Am.* freight car)
- 7 goods shed (*Am.* freight house)
- 8 loading strip
- 9 loading dock
- 10 bale of peat
- 11 bale of linen (of linen cloth)
- 12 fastening (cord)
- 13 wicker bottle (wickered bottle, demijohn)
- 14 trolley
- 15 goods lorry (*Am.* freight truck)
- 16 forklift truck (fork truck, forklift)
- 17 loading siding
- 18 bulky goods
- 19 small railway-owned (*Am.* railroad-owned) container
- 20 showman's caravan (*sim.* circus caravan)
- 21 flat wagon (*Am.* flat freight car)
- 22 loading gauge (*Am.* gage)
- 23 bale of straw
- 24 flat wagon (*Am.* flatcar) with side stakes
- 25 fleet of lorries (*Am.* trucks)
- 26-39 goods shed (*Am.* freight house)
- 26 goods office (forwarding office, *Am.* freight office)
- 27 part-load goods (*Am.* package freight)
- 28 forwarding agent (*Am.* freight agent, shipper)
- 29 loading foreman
- 30 consignment note (waybill)
- 31 weighing machine
- 32 pallet
- 33 porter

- 34 electric cart (electric truck)
- 35 trailer
- 36 loading supervisor
- 37 goods shed door (*Am.* freight house door)
- 38 rail (slide rail)
- 39 roller
- 40 weighbridge office
- 41 weighbridge
- 42 marshalling yard (*Am.* classification yard, switch yard)
- 43 shunting engine (shunting locomotive, shunter, *Am.* switch engine, switcher)
- 44 marshalling yard signal box (*Am.* classification yard switch tower)
- 45 yardmaster
- 46 hump
- 47 sorting siding (classification siding, classification track)
- 48 rail brake (retarder)
- 49 slipper brake (slipper)
- 50 storage siding (siding)
- 51 buffer (buffers, *Am.* bumper)
- 52 wagon load (*Am.* carload)
- 53 warehouse
- 54 container station
- 55 gantry crane
- 56 lifting gear (hoisting gear)
- 57 container
- 58 container wagon (*Am.* container car)
- 59 semi-trailer

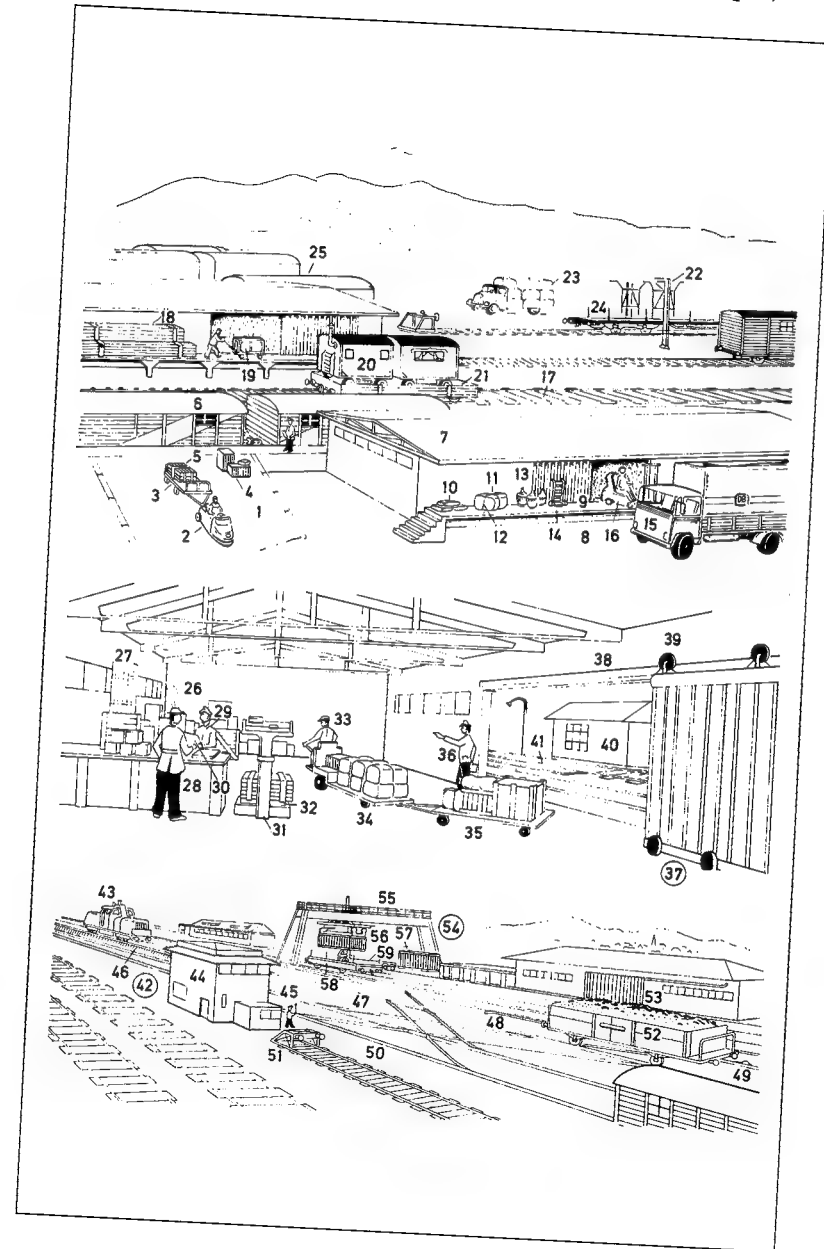

1-21 express train coach (express train carriage, express train car, corridor compartment coach), a passenger coach

- 1 side elevation (side view)
- 2 coach body
- 3 underframe (frame)
- 4 bogie (truck) with steel and rubber suspension and shock absorbers
- 5 battery containers (battery boxes)
- 6 steam and electric heat exchanger for the heating system
- 7 sliding window
- 8 rubber connecting seal
- 9 ventilator

10-21 plan

- 10 second-class section
- 11 corridor
- 12 folding seat (tip-up seat)
- 13 passenger compartment (compartment)
- 14 compartment door
- 15 washroom
- 16 toilet (lavatory, WC)
- 17 first-class section
- 18 swing door
- 19 sliding connecting door
- 20 door
- 21 vestibule

22-32 dining car (restaurant car, diner)

- 22-25 side elevation (side view)
- 22 door
- 23 loading door
- 24 current collector for supplying power during stops
- 25 battery boxes (battery containers)

26-32 plan

- 26 staff washroom
- 27 storage cupboard
- 28 washing-up area
- 29 kitchen
- 30 electric oven with eight hotplates
- 31 counter
- 32 dining compartment
- 33 dining car kitchen
- 34 chef (head cook)
- 35 kitchen cabinet
- 36 sleeping car (sleeper)
- 37 side elevation (side view)
- 38-42 plan**
- 38 two-seat twin-berth compartment (two-seat two-berth compartment, *Am. bedroom*)

- 39 folding doors
- 40 washstand
- 41 office
- 42 toilet (lavatory, WC)
- 43 express train compartment
- 44 upholstered reclining seat
- 45 armrest
- 46 ashtray in the armrest
- 47 adjustable headrest
- 48 antimacassar
- 49 mirror
- 50 coat hook
- 51 luggage rack
- 52 compartment window
- 53 fold-away table (pull-down table)
- 54 heating regulator
- 55 litter receptacle
- 56 curtain
- 57 footrest
- 58 corner seat
- 59 open car
- 60 side elevation (side view)
- 61-72 plan**
- 61 open carriage
- 62 row of single seats
- 63 row of double seats
- 64 reclining seat
- 65 seat upholstery
- 66 backrest
- 67 headrest
- 68 down-filled headrest cushion with nylon cover
- 69 armrest with ashtray
- 70 cloakroom
- 71 luggage compartment
- 72 toilet (lavatory, WC)
- 73 buffet car (quick-service buffet car), a self-service restaurant car
- 74 side elevation (side view)
- 75 current collector for supplying power during stops
- 76 plan
- 77 dining compartment
- 78-79 buffet** (buffet compartment)
- 78 customer area
- 79 serving area
- 80 kitchen
- 81 staff compartment
- 82 staff toilet (staff lavatory, staff WC)
- 83 food compartments
- 84 plates
- 85 cutlery
- 86 till (cash register)

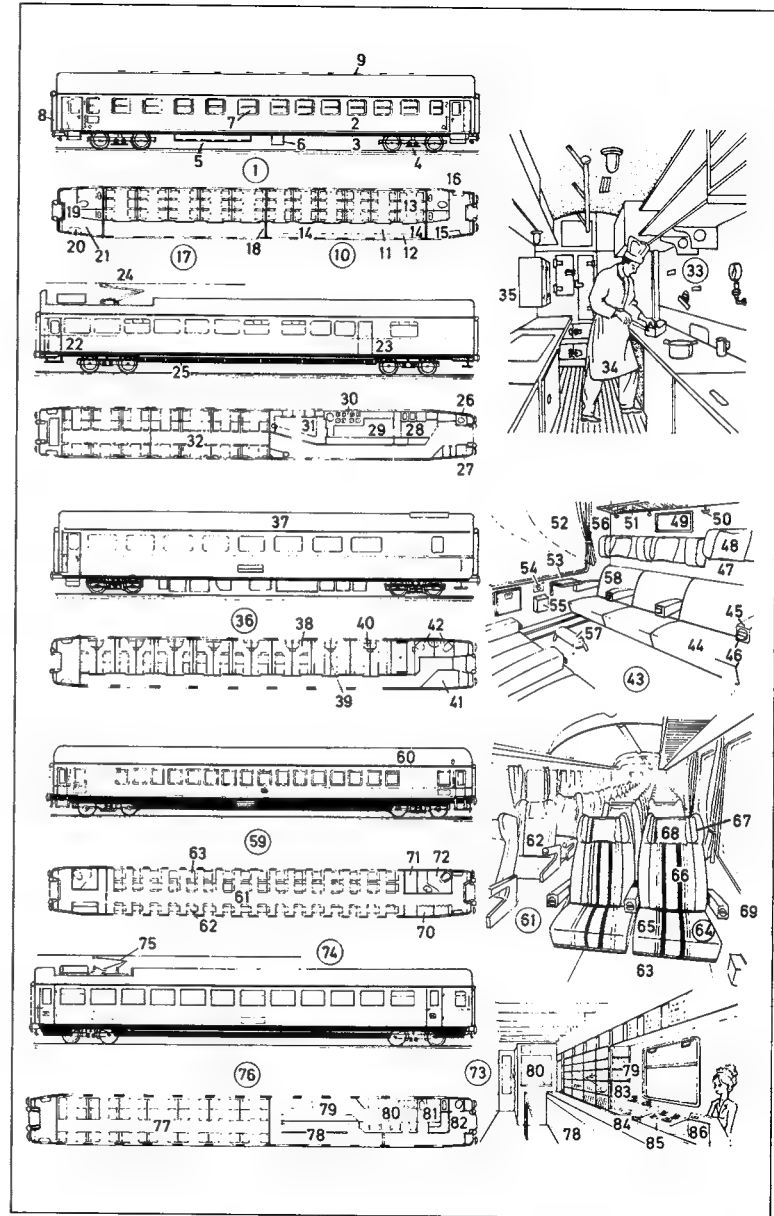

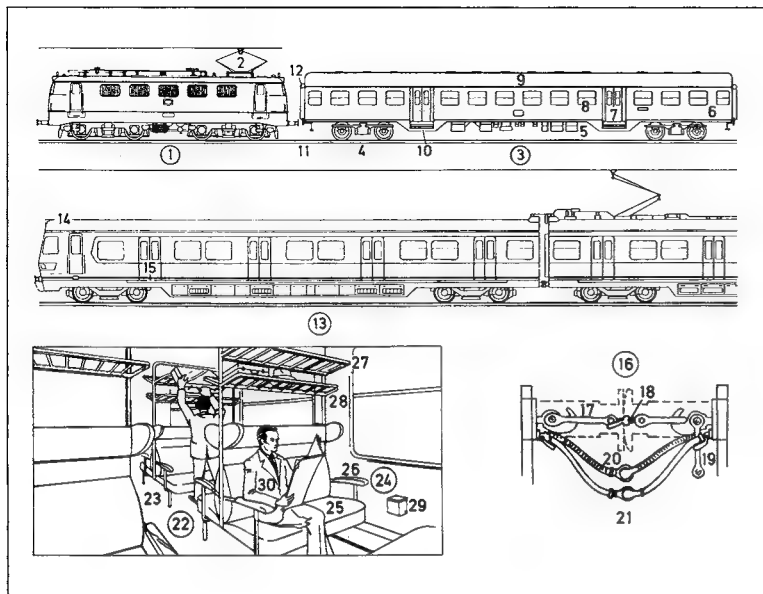
**1-30 local train service****1-12 local train** (short-distance train)

- 1 electric locomotive
- 2 current collector
- 3 four-axled coach (four-axled car) for short-distance routes, a passenger coach (passenger car)
- 4 bogie (truck) [with disc (disk) brakes]
- 5 underframe (frame)
- 6 coach body with metal panelling (*Am.* paneling)
- 7 double folding doors
- 8 compartment window
- 9 open carriage
- 10 entrance
- 11 connecting corridor
- 12 rubber connecting seal
- 13 light railcar, a short-distance railcar
- 14 cab (driver's cab, *Am.* engineer's cab)
- 15 carriage door

16 connecting hoses and coupling

- 17 coupling link
- 18 tensioning device (coupling screw with tensioning lever)
- 19 unlinked coupling
- 20 heating coupling hose (steam coupling hose)
- 21 coupling hose (connecting hose) for the compressed-air braking system
- 22 second-class section
- 23 central gangway
- 24 compartment
- 25 upholstered seat
- 26 armrest
- 27 luggage rack
- 28 hat and light luggage rack
- 29 ashtray
- 30 passenger

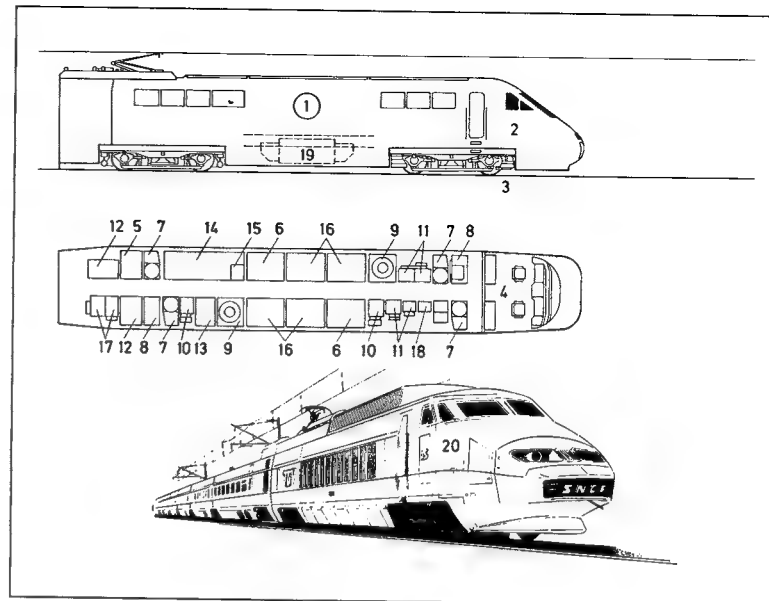
**1-19 Intercity Express**

- 1 German Federal Railway trainset
- 2 driving unit (power car)
- 3 driving bogie with traction motors
- 4 cab (driver's cab, *Am.* engineer's cab)
- 5 power supply (traction current filter)
- 6 contactors (converters, inductance)
- 7 traction motor blower
- 8 inductance protection (converter)
- 9 oil-cooling plant
- 10 converter for the auxiliaries
- 11 electronics
- 12 control current equipment
- 13 auxiliaries (switchgear)
- 14 pneumatic equipment
- 15 air-conditioning plant
- 16 main current converters
- 17 measuring equipment (diagnosis)
- 18 continuous automatic train-running control
- 19 transformer

- 20 TGV (Train à Grande Vitesse) of the Société Nationale des Chemins de Fer Français (SNCF)

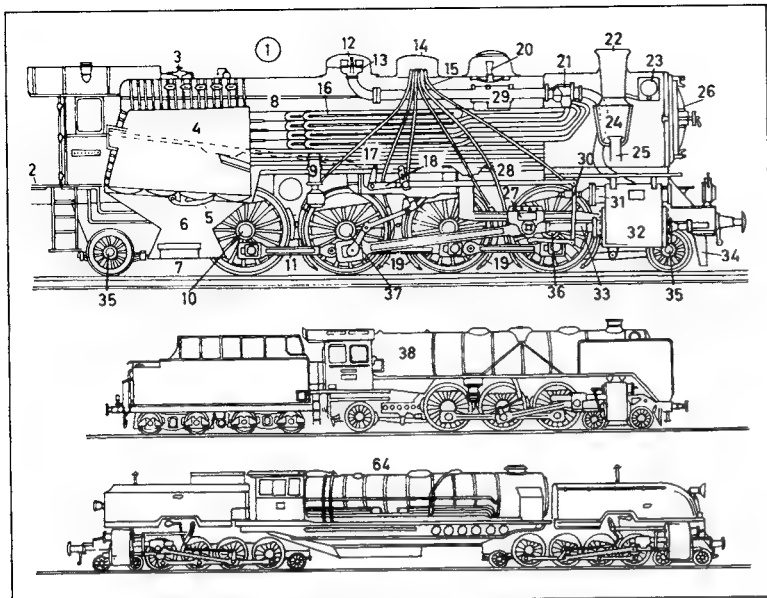
**1-69 steam locomotives****2-37 locomotive boiler and driving gear**

- 2 tender platform with coupling
- 3 safety valve for excess boiler pressure
- 4 firebox
- 5 drop grate
- 6 ashpan with damper doors
- 7 bottom door of the ashpan
- 8 smoke tubes (flue tubes)
- 9 feed pump
- 10 axle bearing
- 11 coupling rod
- 12 steam dome
- 13 regulator valve (regulator main valve)
- 14 sand dome
- 15 sand pipes (sand tubes)
- 16 boiler (boiler barrel)
- 17 fire tubes or steam tubes
- 18 reversing gear (steam reversing gear)
- 19 sand pipes

- 20 feed valve
- 21 steam collector
- 22 chimney (smokestack, smoke outlet and waste steam exhaust)
- 23 feedwater preheater (feedwater heater, economizer)
- 24 spark arrester
- 25 blast pipe
- 26 smokebox door
- 27 cross head
- 28 mud drum
- 29 top feedwater tray
- 30 combination lever
- 31 steam chest
- 32 cylinder
- 33 piston rod with stuffing box (packing box)
- 34 guard iron (rail guard, *Am. pilot, cowcatcher*)
- 35 carrying axle (running axle, dead axle)
- 36 coupled axle
- 37 driving axle
- 38 express locomotive with tender

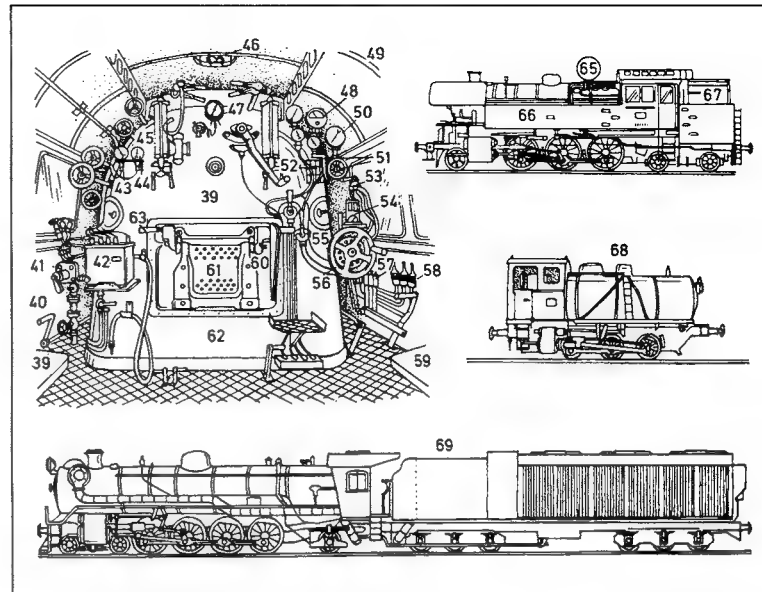

- 39-63 cab (driver's cab, *Am. engineer's cab*)
- 39 fireman's seat
- 40 drop grate lever
- 41 line steam injector
- 42 automatic lubricant pump (automatic lubricator)
- 43 preheater pressure gauge (*Am. gage*)
- 44 carriage heating pressure gauge (*Am. gage*)
- 45 water gauge (*Am. gage*)
- 46 light
- 47 boiler pressure gauge (*Am. gage*)
- 48 distant-reading temperature gauge (*Am. gage*)
- 49 cab (driver's cab, *Am. engineer's cab*)
- 50 brake pressure gauge (*Am. gage*)
- 51 whistle valve handle
- 52 driver's timetable (*Am. engineer's schedule*)
- 53 driver's brake valve (*Am. engineer's brake valve*)

- 54 speed recorder (tachograph)
- 55 sanding valve
- 56 reversing wheel
- 57 emergency brake valve
- 58 release valve
- 59 driver's seat (*Am. engineer's seat*)
- 60 firehole shield
- 61 firehole door
- 62 vertical boiler
- 63 firedoor handle handgrip
- 64 articulated locomotive (Garratt locomotive)
- 65 tank locomotive
- 66 water tank
- 67 fuel tender
- 68 steam storage locomotive (fireless locomotive)
- 69 condensing locomotive (locomotive with condensing tender)

- 1 electric locomotive
- 2 current collector
- 3 main switch
- 4 high-tension transformer
- 5 roof cable
- 6 traction motor
- 7 inductive train control system
- 8 main air reservoir
- 9 whistle
- 10-18 plan of locomotive**
- 10 transformer with tap changer
- 11 oil cooler with blower
- 12 oil-circulating pump
- 13 tap changer driving mechanism
- 14 air compressor
- 15 traction motor blower
- 16 terminal box
- 17 capacitors for auxiliary motors
- 18 commutator cover
- 19 cab (driver's cab, *Am.* engineer's cab)
- 20 controller handwheel
- 21 dead man's handle
- 22 driver's brake valve (*Am.* engineer's brake valve)
- 23 ancillary brake valve (auxiliary brake valve)
- 24 pressure gauge (*Am.* gage)
- 25 bypass switch for the dead man's handle
- 26 tractive effort indicator
- 27 train heating voltage indicator
- 28 contact wire voltage indicator (overhead wire voltage indicator)
- 29 high-tension voltage indicator
- 30 on/off switch for the current collector
- 31 main switch
- 32 sander switch (sander control)
- 33 anti-skid brake switch
- 34 visual display for the ancillary systems
- 35 speedometer
- 36 running step indicator
- 37 clock
- 38 controls for the inductive train control system

- 39 cab heating switch
- 40 whistle lever
- 41 **contact wire maintenance vehicle** (overhead wire maintenance vehicle), a diesel railcar
- 42 work platform (working platform)
- 43 ladder
- 44-54 mechanical equipment of the contact wire maintenance vehicle**
- 44 air compressor
- 45 blower oil pump
- 46 generator
- 47 diesel engine
- 48 injection pump
- 49 silencer (*Am.* muffler)
- 50 change-speed gear
- 51 cardan shaft
- 52 wheel flange lubricator
- 53 reversing gear
- 54 torque converter bearing
- 55 **accumulator railcar** (battery railcar)
- 56 battery box (battery container)
- 57 cab (driver's cab, *Am.* engineer's cab)
- 58 second-class seating arrangement
- 59 toilet (lavatory, WC)
- 60 **fast electric multiple-unit train**
- 61 front railcar
- 62 driving trailer car

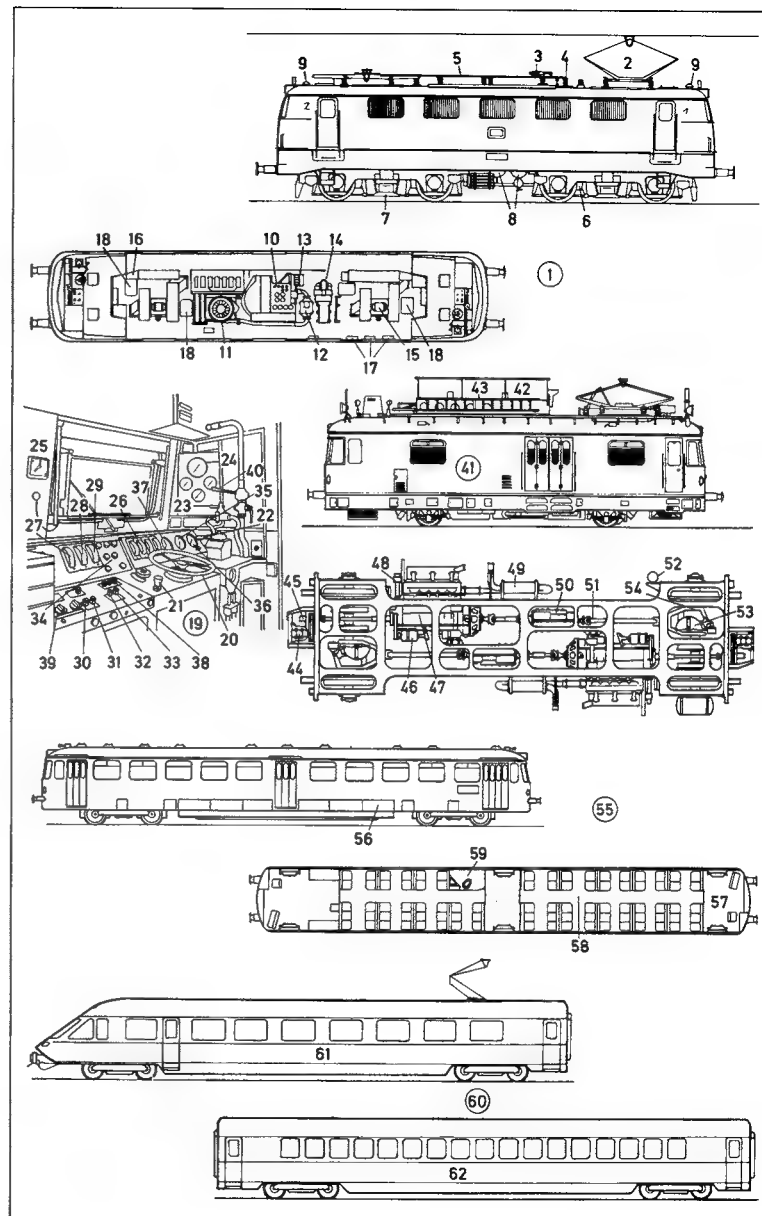

1-84 diesel locomotives

- 1 diesel-hydraulic locomotive, a mainline locomotive (diesel locomotive) for medium passenger and goods service (freight service)
- 2 bogie (truck)
- 3 wheel and axle set
- 4 main fuel tank
- 5 cab (driver's cab, *Am.* engineer's cab) of a diesel locomotive
- 6 main air pressure gauge (*Am.* gage)
- 7 brake cylinder pressure gauge (*Am.* gage)
- 8 main air reservoir pressure gauge (*Am.* gage)
- 9 speedometer
- 10 auxiliary brake
- 11 driver's brake valve (*Am.* engineer's brake valve)
- 12 controller handwheel
- 13 dead man's handle
- 14 inductive train control system
- 15 signal lights
- 16 clock
- 17 voltage meter for the train heating system
- 18 current meter for the train heating system
- 19 engine oil temperature gauge (*Am.* gage)
- 20 transmission oil temperature gauge (*Am.* gage)
- 21 cooling water temperature gauge (*Am.* gage)
- 22 revolution counter (rev counter, tachometer)
- 23 radio telephone
- 24 diesel-hydraulic locomotive [plan and elevation]
- 25 diesel engine
- 26 cooling unit
- 27 fluid transmission
- 28 wheel and axle drive
- 29 cardan shaft
- 30 starter motor
- 31 instrument panel
- 32 driver's control desk (*Am.* engineer's control desk)
- 33 hand brake
- 34 air compressor with electric motor
- 35 equipment locker
- 36 heat exchanger for transmission oil
- 37 engine room ventilator
- 38 magnet for the inductive train control system
- 39 train heating generator

- 40 casing of the train heating system transformer
- 41 preheater
- 42 exhaust silencer (*Am.* exhaust muffler)
- 43 auxiliary heat exchanger for the transmission oil
- 44 hydraulic brake
- 45 tool box
- 46 starter battery
- 47 diesel-hydraulic locomotive for light and medium shunting service
- 48 exhaust silencer (*Am.* exhaust muffler)
- 49 bell and whistle
- 50 yard radio
- 51-67 elevation of locomotive
- 51 diesel engine with supercharged turbine
- 52 fluid transmission
- 53 output gear box
- 54 radiator
- 55 heat exchanger for the engine lubricating oil
- 56 fuel tank
- 57 main air reservoir
- 58 air compressor
- 59 sand boxes
- 60 reserve fuel tank
- 61 auxiliary air reservoir
- 62 hydrostatic fan drive
- 63 seat with clothes compartment
- 64 hand brake wheel
- 65 cooling water
- 66 ballast
- 67 engine and transmission control wheel
- 68 small diesel locomotive for shunting service
- 69 exhaust casing
- 70 horn
- 71 main air reservoir
- 72 air compressor
- 73 eight-cylinder diesel engine
- 74 Voith transmission with reversing gear
- 75 heating oil tank (fuel oil tank)
- 76 sand box
- 77 cooling unit
- 78 header tank for the cooling water
- 79 oil bath air cleaner (oil bath air filter)
- 80 hand brake wheel
- 81 control wheel
- 82 coupling
- 83 cardan shaft
- 84 louvred shutter

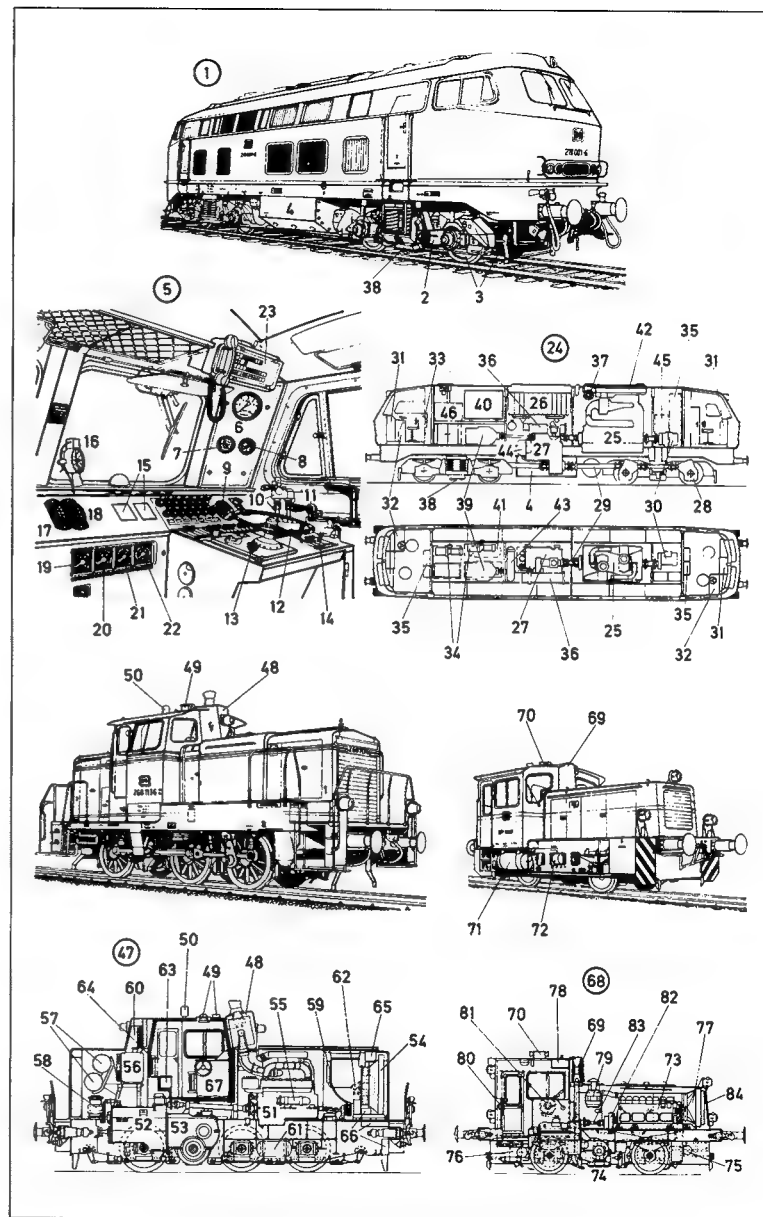

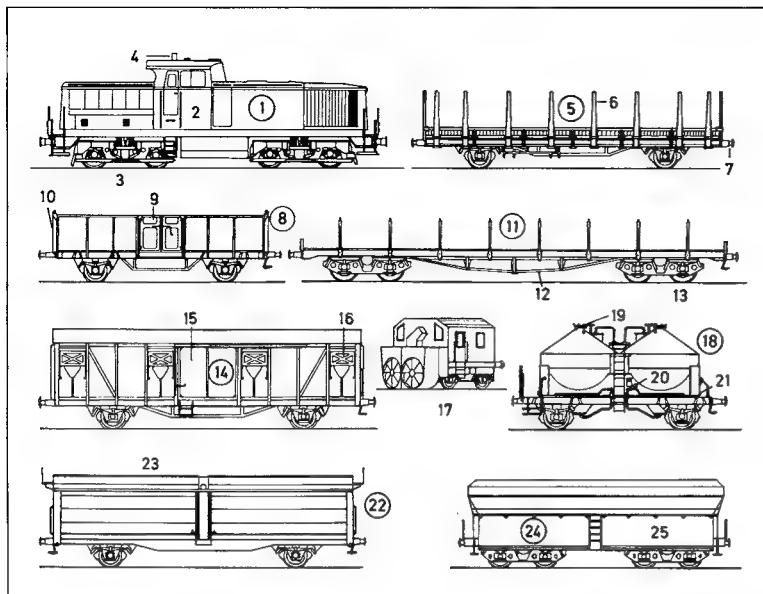

- | | |
|---|--|
| 1 diesel-hydraulic locomotive | 17 snow blower (rotary snow plough, <i>Am.</i> snowplow), a track-clearing vehicle |
| 2 cab (driver's cab, <i>Am.</i> engineer's cab) | 18 wagon (<i>Am.</i> car) with pneumatic discharge |
| 3 wheel and axle set | 19 filler hole |
| 4 aerial for the yard radio | 20 compressed-air supply |
| 5 standard flat wagon (<i>Am.</i> standard flatcar) | 21 discharge connection valve |
| 6 hinged steel stanchion (stanchion) | 22 goods van (<i>Am.</i> boxcar) with sliding roof |
| 7 buffers | 23 roof opening |
| 8 standard open goods wagon (<i>Am.</i> standard open freight car) | 24 bogie open self-discharge wagon (<i>Am.</i> bogie open self-discharge freight car) |
| 9 revolving side doors | 25 discharge flap (discharge door) |
| 10 hinged front | |
| 11 standard flat wagon (<i>Am.</i> standard flatcar) with bogies | |
| 12 sole bar reinforcement | |
| 13 bogie (truck) | |
| 14 covered goods van (covered goods wagon, <i>Am.</i> boxcar) | |
| 15 sliding door | |
| 16 ventilation flap | |

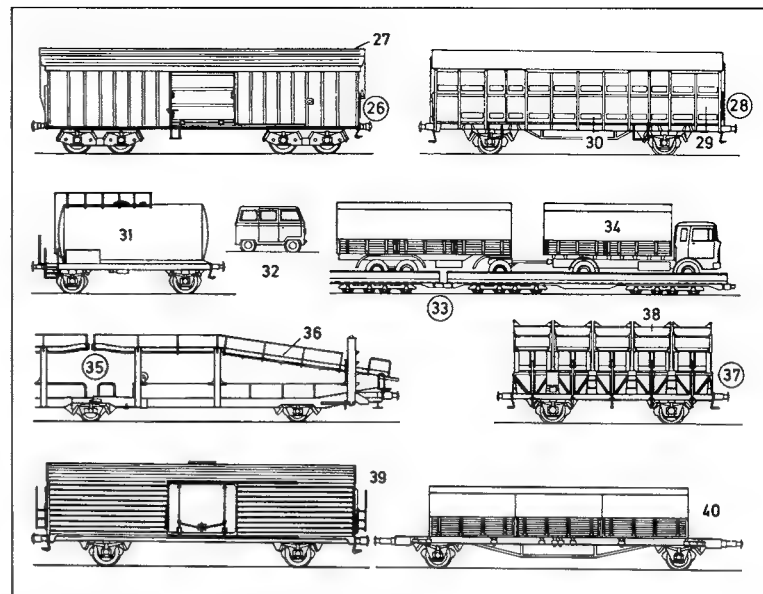

- | | |
|---|--|
| 26 bogie wagon with swivelling (<i>Am.</i> swiveling) roof | 40 interchangeable bodies for flat wagons (<i>Am.</i> flatcars) |
| 27 swivelling (<i>Am.</i> swiveling) roof | |
| 28 large-capacity wagon (<i>Am.</i> large-capacity car) for small livestock | |
| 29 sidewall with ventilation flaps (slatted wall) | |
| 30 ventilation flap | |
| 31 tank wagon (<i>Am.</i> tank car) | |
| 32 track inspection railcar | |
| 33 open special wagons (<i>Am.</i> open special freight cars) | |
| 34 lorry (<i>Am.</i> truck) with trailer | |
| 35 two-tier car carrier (double-deck car carrier) | |
| 36 hinged upper deck | |
| 37 tipper wagon (<i>Am.</i> dump car) with skips | |
| 38 skip | |
| 39 general-purpose refrigerator wagon (refrigerator van, <i>Am.</i> refrigerator car) | |

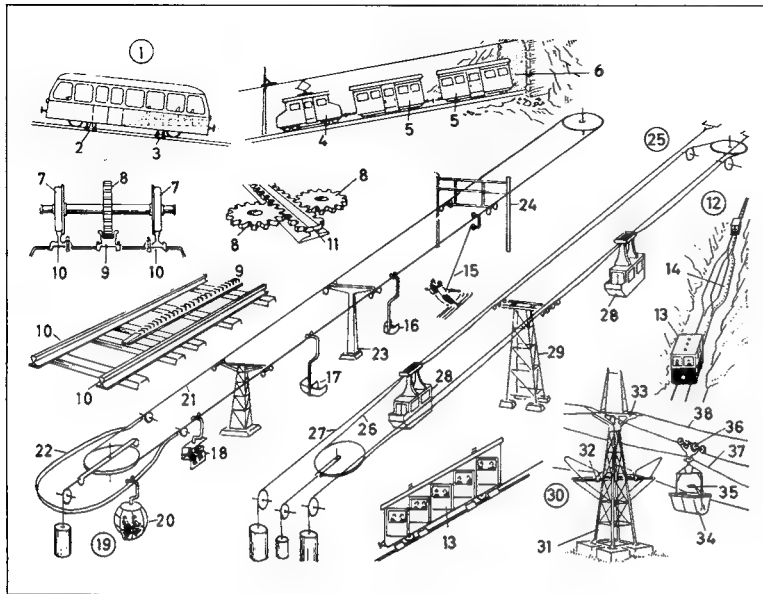
**1-14 mountain railways (Am. mountain railroads)**

- 1 adhesion railcar
- 2 drive
- 3 emergency brake
- 4, 5 rack mountain railway (rack-and-pinion railway, cog railway, Am. cog railroad, rack railroad)
- 4 electric rack railway locomotive (Am. electric rack railroad locomotive)
- 5 rack railway coach (rack railway trailer, Am. rack railroad car)
- 6 tunnel
- 7-11 rack railways (rack-and-pinion railways, Am. rack railroads) [systems]
- 7 running wheel (carrying wheel)
- 8 driving pinion
- 9 rack [with teeth machined on top edge]
- 10 rail
- 11 rack [with teeth on both outer edges]
- 12 funicular railway (funicular, cable railway)
- 13 funicular railway car
- 14 haulage cable

15-38 cableways (ropeways, cable suspension lines)

- 15-24 single-cable ropeways (single-cable suspension lines), endless cableways, endless ropeways
- 15 drag lift

16-18 chair lift

- 16 lift chair, a single chair
- 17 double lift chair, a two-seater chair
- 18 double chair (two-seater chair) with coupling

19 gondola cableway, an endless cableway

- 20 gondola (cabin)
- 21 endless cable, a suspension (supporting) and haulage cable

22 U-rail

- 22 U-rail
- 23 single-pylon support
- 24 gantry support
- 25 double-cable ropeway (double-cable suspension line), a suspension line with balancing cabins

26 haulage cable

- 26 haulage cable
- 27 suspension cable (supporting cable)
- 28 cabin
- 29 intermediate support
- 30 cableway (ropeway, suspension line), a double-cable ropeway (double-cable suspension line)
- 31 pylon
- 32 haulage cable roller
- 33 cable guide rail (suspension cable bearing)
- 34 skip, a tipping bucket (Am. dumping bucket)
- 35 stop
- 36 pulley cradle
- 37 haulage cable

- 38 suspension cable (supporting cable)
- 39 valley station (lower station)
- 40 tension weight shaft
- 41 tension weight for the suspension cable (supporting cable)
- 42 tension weight for the haulage cable
- 43 tension cable pulley
- 44 suspension cable (supporting cable)
- 45 haulage cable
- 46 balance cable (lower cable)
- 47 auxiliary cable (emergency cable)
- 48 auxiliary-cable tensioning mechanism (emergency-cable tensioning mechanism)
- 49 haulage cable rollers
- 50 spring buffer (Am. spring bumper)
- 51 valley station platform (lower station platform)
- 52 cabin (cableway gondola, ropeway gondola, suspension line gondola), a large-capacity cabin
- 53 pulley cradle
- 54 suspension gear
- 55 stabilizer
- 56 guide rail
- 57 top station (upper station)
- 58 suspension cable guide (supporting cable guide)
- 59 suspension cable anchorage (supporting cable anchorage)
- 60 haulage cable rollers
- 61 haulage cable guide wheel
- 62 haulage cable driving pulley
- 63 main drive
- 64 standby drive
- 65 control room
- 66 cabin pulley cradle
- 67 main pulley cradle
- 68 double cradle
- 69 two-wheel cradle
- 70 running wheels
- 71 suspension cable brake (supporting cable brake), an emergency brake in case of haulage cable failure
- 72 suspension gear bolt
- 73 haulage cable sleeve
- 74 balance cable sleeve (lower cable sleeve)
- 75 derailment guard
- 76 cable supports (ropeway supports, suspension line supports, intermediate supports)
- 77 pylon, a framework support
- 78 tubular steel pylon, a tubular steel support
- 79 suspension cable guide rail (supporting cable guide rail, support guide rail)
- 80 support truss, a frame for work on the cable
- 81 base of the support

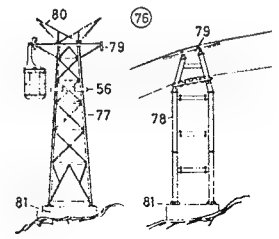
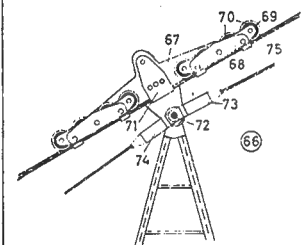
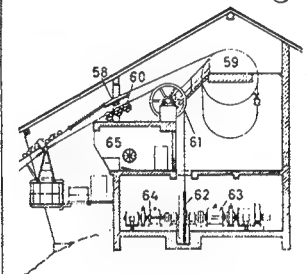
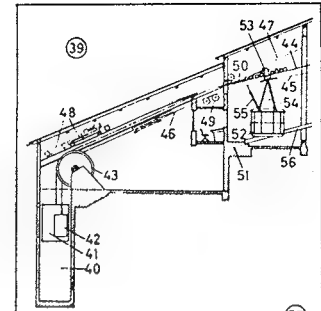

- 1 cross-section of a bridge
- 2 orthotropic roadway (orthotropic deck)
- 3 truss (bracing)
- 4 diagonal brace (diagonal strut)
- 5 hollow tubular section
- 6 deck slab
- 7 solid-web girder bridge (beam bridge)
- 8 road surface
- 9 top flange
- 10 bottom flange
- 11 fixed bearing
- 12 movable bearing
- 13 clear span
- 14 span
- 15 rope bridge (primitive suspension bridge)
- 16 carrying rope
- 17 suspension rope
- 18 woven deck (woven decking)
- 19 stone arch bridge, a solid bridge
- 20 arch
- 21 pier
- 22 statue
- 23 trussed arch bridge
- 24 truss element
- 25 trussed arch
- 26 arch span
- 27 abutment (end pier)
- 28 spandrel-braced arch bridge
- 29 abutment (abutment pier)
- 30 bridge strut
- 31 crown
- 32 covered bridge of the Middle Ages (the *Ponte Vecchio* in Florence)
- 33 goldsmiths' shops
- 34 steel lattice bridge
- 35 counterbrace (crossbrace, diagonal member)
- 36 vertical member
- 37 truss joint
- 38 portal frame
- 39 suspension bridge
- 40 suspension cable
- 41 suspender (hanger)
- 42 tower
- 43 suspension cable anchorage
- 44 tied beam [with roadway]
- 45 abutment
- 46 cable-stayed bridge
- 47 inclined tension cable
- 48 inclined cable anchorage
- 49 reinforced concrete bridge
- 50 reinforced concrete arch
- 51 inclined cable system (multiple cable system)
- 52 flat bridge, a plate girder bridge
- 53 stiffener
- 54 pier
- 55 bridge bearing
- 56 cutwater
- 57 straits bridge, a bridge built of precast elements
- 58 precast construction unit
- 59 viaduct
- 60 valley bottom
- 61 reinforced concrete pier
- 62 scaffolding
- 63 lattice swing bridge
- 64 turntable
- 65 pivot pier
- 66 pivoting half (pivoting section, pivoting span, movable half) of bridge
- 67 flat swing bridge
- 68 middle section
- 69 pivot
- 70 parapet (handrailing)

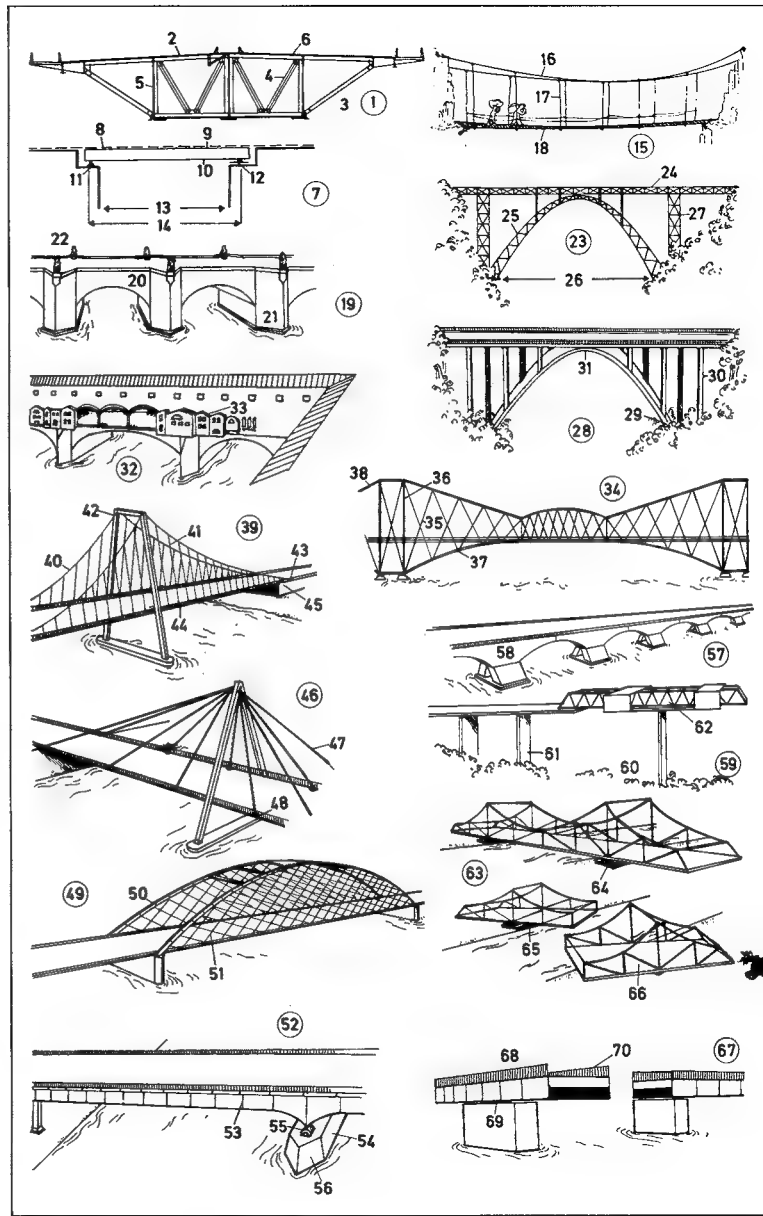

- 1 cable ferry (also: chain ferry), a passenger ferry
- 2 ferry rope (ferry cable)
- 3 river branch (river arm)
- 4 river island (river islet)
- 5 collapsed section of riverbank, flood damage
- 6 motor ferry
- 7 ferry landing stage (motorboat landing stage)
- 8 pile foundations
- 9 current (flow, course)
- 10 flying ferry (river ferry), a car ferry
- 11 ferry boat
- 12 buoy (float)
- 13 anchorage
- 14 harbour (*Am.* harbor) for laying up river craft
- 15 ferry boat (punt)
- 16 pole (punt pole, quant pole)
- 17 ferryman
- 18 blind river branch (blind river arm)
- 19 groyne (*Am.* groin)
- 20 groyne (*Am.* groin) head
- 21 fairway (navigable part of river)
- 22 train of barges
- 23 river tug
- 24 tow rope (tow line, towing hawser)
- 25 barge (freight barge, cargo barge, lighter)
- 26 bargeman (bargee, lighterman)
- 27 towing (hauling, haulage)
- 28 towing mast
- 29 towing engine
- 30 towing track; *form.*: tow path (towing path)
- 31 river after river training
- 32 dike (dyke, main dike, flood wall, winter dike)
- 33 drainage ditch
- 34 dike (dyke) drainage sluice
- 35 wing wall
- 36 outfall
- 37 drain (infiltration drain)
- 38 berm (berme)
- 39 top of dike (dyke)
- 40 dike (dyke) batter (dike slope)
- 41 flood bed (inundation area)
- 42 flood containment area
- 43 current meter
- 44 kilometre (*Am.* kilometer) sign
- 45 dikereeve's (dykereeve's) house (dikereeve's cottage); also: ferryman's house (cottage)
- 46 dikereeve (dykereeve)
- 47 dike (dyke) ramp
- 48 summer dike (summer dyke)
- 49 levee (embankment)
- 50 sandbags
- 51-55 bank protection (bank stabilization, revetment)
 - 51 riprap
 - 52 alluvial deposit (sand deposit)
 - 53 fascine (bundle of wooden sticks)
 - 54 wicker fences
 - 55 stone pitching
- 56 floating dredging machine (dredger, a multi-bucket ladder dredge)
 - 57 bucket elevator chain
 - 58 dredging bucket
- 59 suction dredger (hydraulic dredger) with trailing suction pipe or barge sucker
 - 60 centrifugal pump
 - 61 back scouring valve
 - 62 suction pump, a jet pump with scouring nozzles

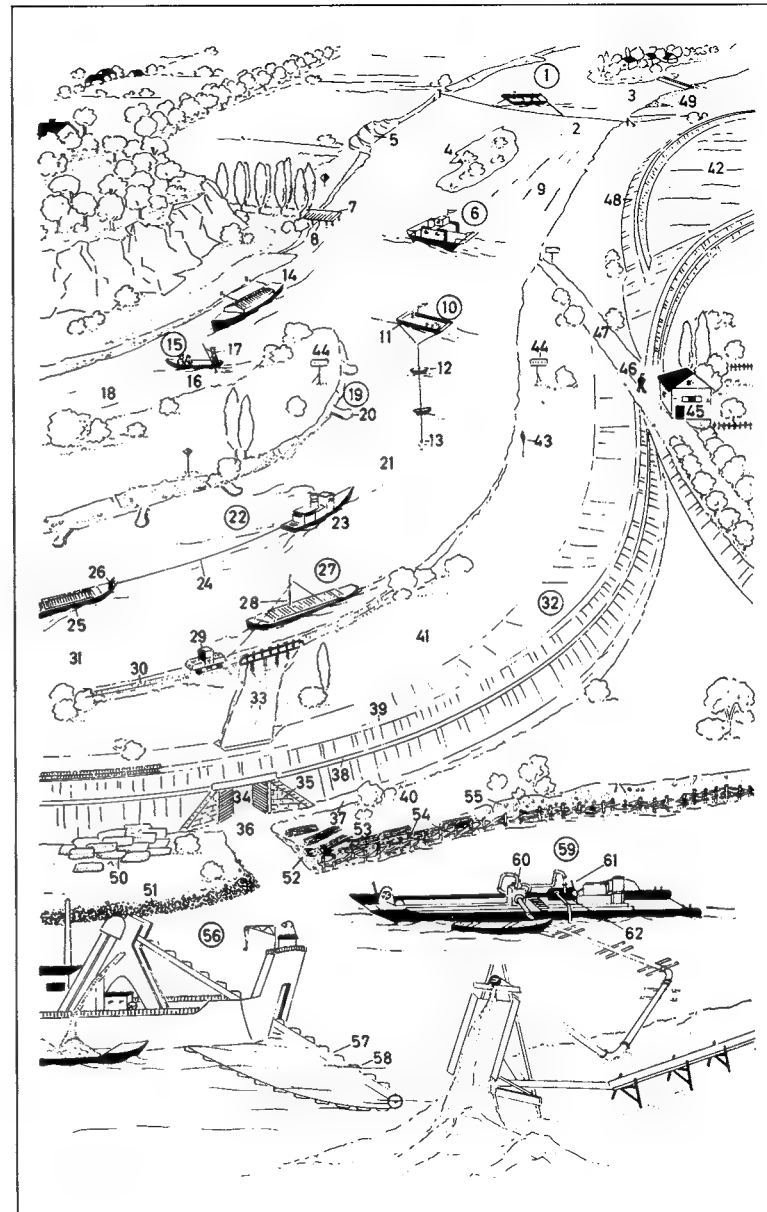

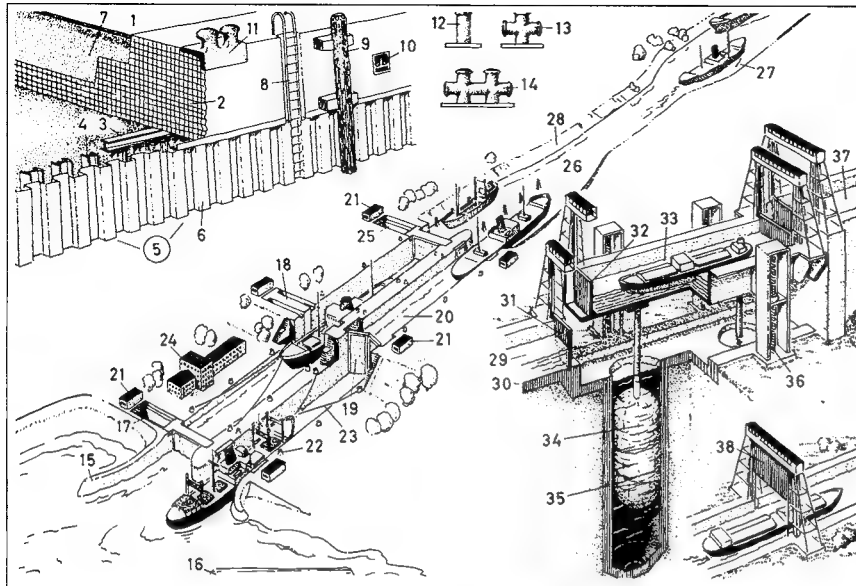

- 1-14 quay wall**
 1 road surface
 2 body of wall
 3 steel sleeper
 4 steel pile
 5 sheet pile wall (sheet pile bulkhead, sheet piling)
 6 box pile
 7 backfilling (filling)
 8 ladder
 9 fender (fender pile)
 10 recessed bollard
 11 double bollard
 12 bollard
 13 cross-shaped bollard (cross-shaped mooring bitt)
 14 double cross-shaped bollard (double cross-shaped mooring bitt)
- 15-28 canal**
 15, 16 canal entrance
 15 mole
 16 breakwater
 17-25 staircase of locks
 17 lower level
 18 lock gate, a sliding gate
 19 mitre (*Am.* miter) gate
- 20 lock (lock chamber)**
 21 power house
 22 warping capstan (hauling capstan), a capstan
 23 warp
 24 offices (e.g. canal administration, river police, customs)
 25 upper level (head)
 26 lock approach
 27 lay-by
 28 bank slope
- 29-38 boat lift (*Am.* boat elevator)**
 29 lower pound (lower reach)
 30 canal bed
 31 pound lock gate, a vertical gate
 32 lock gate
 33 boat tank (caisson)
 34 float
 35 float shaft
 36 lifting spindle
 37 upper pound (upper reach)
 38 vertical gate

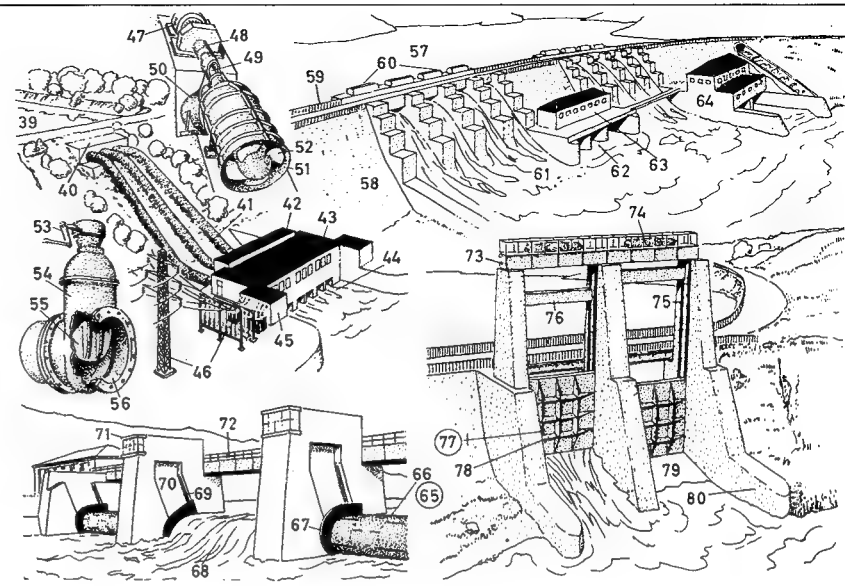

- 39-46 pumping plant and reservoir**
 39 forebay
 40 surge tank
 41 pressure pipeline
 42 valve house (valve control house)
 43 turbine house (pumping station)
 44 discharge structure (outlet structure)
 45 control station
 46 transformer station
- 47-52 axial-flow pump (propeller pump)**
 47 drive motor
 48 gear
 49 drive shaft
 50 pressure pipe
 51 suction head
 52 impeller wheel
- 53-56 sluice valve (sluice gate)**
 53 crank drive
 54 valve housing
 55 sliding valve (sliding gate)
 56 discharge opening
- 57-64 dam (barrage)**
 57 reservoir (storage reservoir, impounding reservoir, impounded reservoir)
 58 masonry dam
 59 crest of dam
- 60 spillway (overflow spillway)**
 61 stilling basin (stilling box, stilling pool)
 62 scouring tunnel (outlet tunnel, waste water outlet)
 63 valve house (valve control house)
 64 power station
- 65-72 rolling dam (weir), a barrage; other system: shutter weir**
 65 roller, a barrier
 66 roller top
 67 flange
 68 submersible roller
 69 rack track
 70 recess
 71 hoisting gear cabin
 72 service bridge (walkway)
- 73-80 sluice dam**
 73 hoisting gear bridge
 74 hoisting gear (winding gear)
 75 guide groove
 76 counterweight (counterpoise)
 77 sluice gate (floodgate)
 78 reinforcing rib
 79 dam sill (weir sill)
 80 wing wall

- 1-6 Germanic rowing boat** [ca. AD 400]; the Nydam boat
1 stern post
2 steersman
3 oarsman
4 stem post (stem)
5 oar, for rowing
6 rudder (steering oar), a side rudder, for steering
7 dugout, a hollowed-out tree trunk
8 paddle
9-12 trireme, a Roman warship
9 ram
10 forecastle (fo'c'sle)
11 grapple (grapnel, grappling iron), for fastening the enemy ship alongside
12 three banks (tiers) of oars
13-17 Viking ship (longship, dragon ship) [Norse]
13 helm (tiller)
14 awning crutch with carved horses' heads
15 awning
16 dragon figurehead
17 shield
18-26 cog (Hansa cog, Hansa ship)
18 anchor cable (anchor rope, anchor hawser)
19 forecastle (fo'c'sle)
20 bowsprit
21 furled (brailed-up) square sail
22 town banner (city banner)
23 aftercastle (sterncastle)
24 rudder, a stem rudder
25 elliptical stern (round stern)
26 wooden fender
27-43 caravel (carvel) ['Santa Maria' 1492]
27 admiral's cabin
28 spanker boom
29 mizzen (mizen, mutton spanker, lateen spanker), a lateen sail
30 lateen yard
31 mizzen (mizen) mast
32 lashing

- 33** mainsail (main course), a square sail
34 bonnet, a removable strip of canvas
35 bowline
36 bunt line (martinet)
37 main yard
38 main topsail
39 main topsail yard
40 mainmast
41 foresail (fore course)
42 foremast
43 spritsail
44-50 galley [15th to 18th century], a slave galley
44 lantern
45 cabin
46 central gangway
47 slave driver with whip
48 galley slaves
49 covered platform in the forepart of the ship
50 gun
51-60 ship of the line (line-of-battle ship) [18th to 19th century], a three-decker
51 jib boom
52 fore topgallant sail
53 main topgallant sail
54 mizzen (mizen) topgallant sail
55-57 gilded stern
55 upper stern
56 stern gallery
57 quarter gallery, a projecting balcony with ornamental portholes
58 lower stern
59 gunports for broadside fire
60 gunport shutter

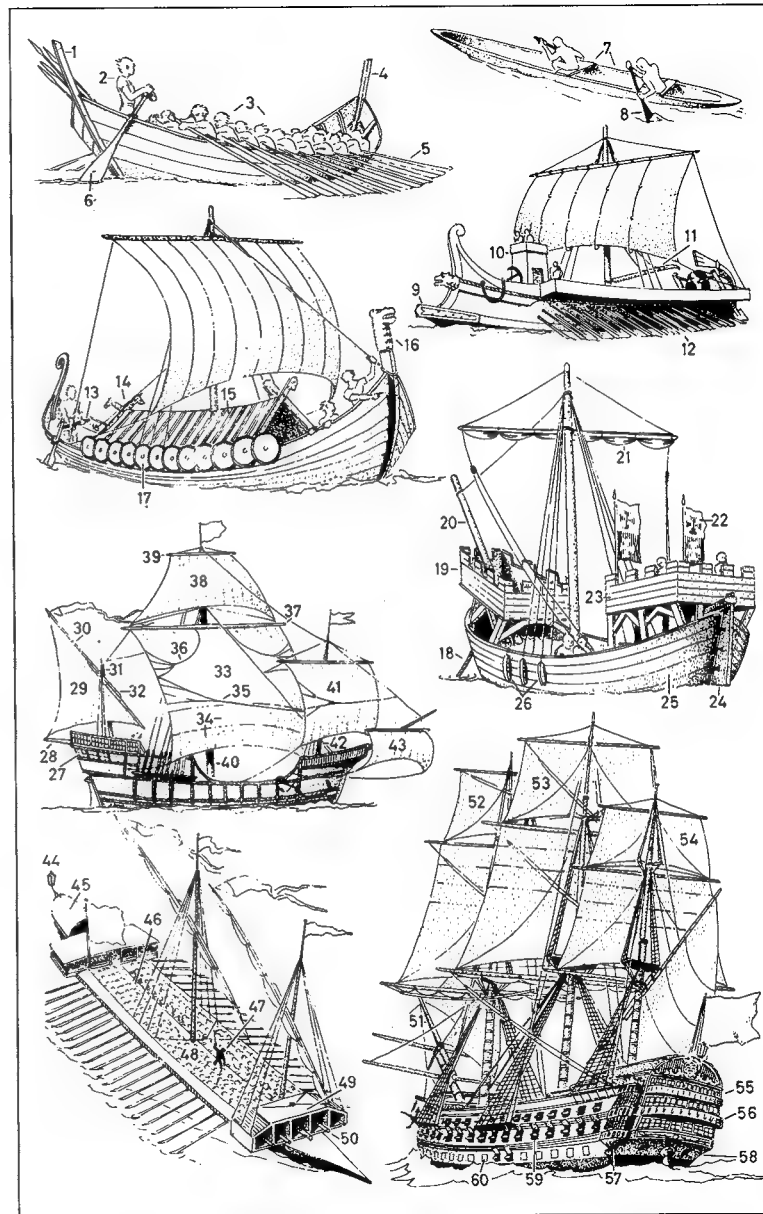

219 Sailing Ship I

1-72 rigging (rig, tackle) and sails of a bark (barque)**1-9 masts**

1 bowsprit with jib boom

2-4 foremast

2 lower foremast

3 fore topmast

4 fore topgallant mast

5-7 mainmast

5 lower mainmast

6 main topmast

7 main topgallant mast

8, 9 mizzen (mizen) mast

8 lower mizzen (lower mizen)

9 mizzen (mizen) topmast

10-19 standing rigging

10 forestay, mizzen (mizen) stay, mainstay

11 fore topmast stay, main topmast stay, mizzen (mizen) topmast stay

12 fore topgallant stay, mizzen (mizen) topgallant stay, main topgallant stay

13 fore royal stay (main royal stay)

14 jib stay

15 bobstay

16 shrouds

17 fore topmast rigging (main topmast rigging, mizzen (mizen) topmast rigging)

18 fore topgallant rigging (main topgallant rigging)

19 backstays

20-31 fore-and-aft sails

20 fore topmast staysail

21 inner jib

22 outer jib

23 flying jib

24 main topmast staysail

25 main topgallant staysail

26 main royal staysail

27 mizzen (mizen) staysail

28 mizzen (mizen) topmast staysail

29 mizzen (mizen) topgallant staysail

30 mizzen (mizen, spanker, driver)

31 gaff topsail

32-45 spars

32 foreyard

33 lower fore topsail yard

34 upper fore topsail yard

35 lower fore topgallant yard

36 upper fore topgallant yard

37 fore royal yard

38 main yard

39 lower main topsail yard

40 upper main topsail yard

41 lower main topgallant yard

42 upper main topgallant yard

43 main royal yard

44 spanker boom

45 spanker gaff

46 footrope

47 lifts

48 spanker boom topping lift

49 spanker peak halyard

50 foretop

51 fore topmast crosstrees

52 maintop

53 main topmast crosstrees

54 mizzen (mizen) top

55-66 square sails

55 foresail (fore course)

56 lower fore topsail

57 upper fore topsail

58 lower fore topgallant sail

59 upper fore topgallant sail

60 fore royal

61 mainsail (main course)

62 lower main topsail

63 upper main topsail

64 lower main topgallant sail

65 upper main topgallant sail

66 main royal sail

67-71 running rigging

67 braces

68 sheets

69 spanker sheet

70 spanker vangs

71 bunt line

72 reef

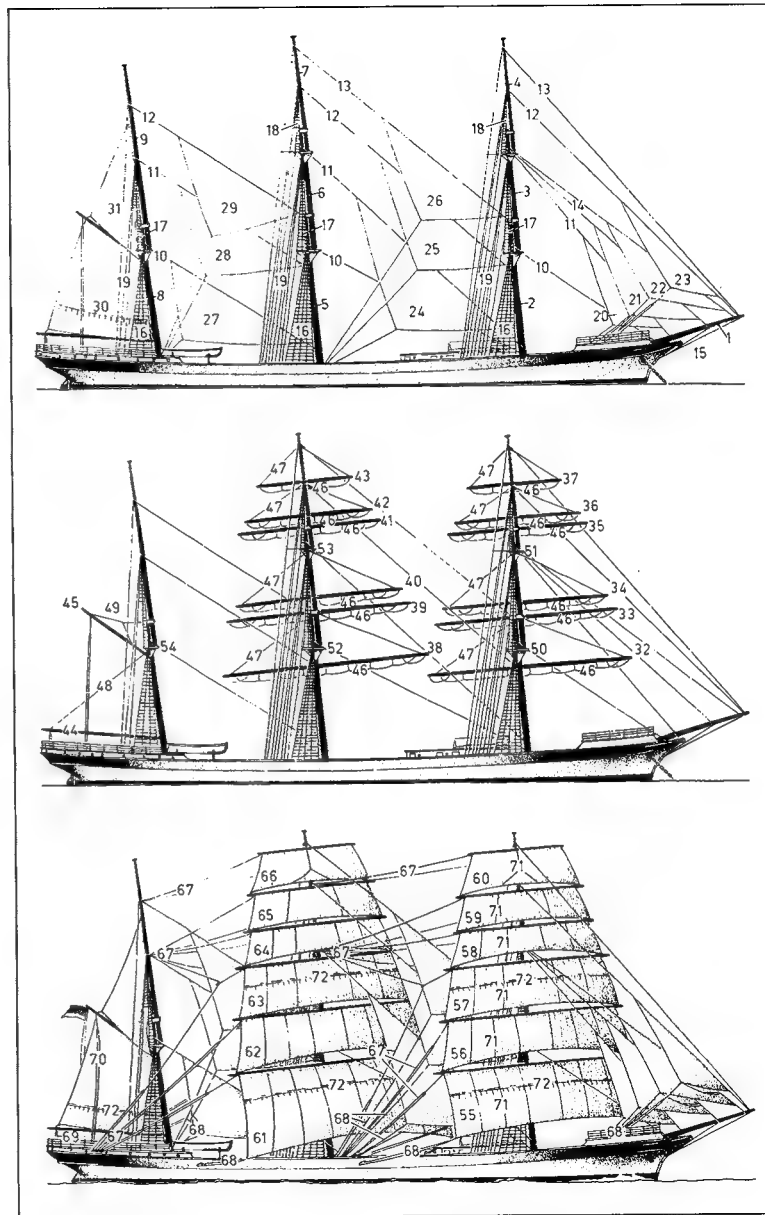

1-5 sail shapes

- 1 gaffsail (*small*: trysail, spencer)
 2 jib
 3 lateen sail
 4 lugsail
 5 spritsail

6-8 single-masted sailing boats (*Am.* sailboats)

- 6 tjalk
 7 leeboard
 8 cutter

9, 10 mizzen (mizen) masted sailing boats (*Am.* sailboats)

- 9 ketch-rigged sailing barge
 10 yawl

11-17 two-masted sailing boats (*Am.* sailboats)**11-13 topsail schooner**

- 11 mainsail
 12 boom foresail
 13 square foresail
 14 brigantine
 15 half-rigged mast with fore-and-aft sails

16 full-rigged mast with square sails**17 brig****18-27 three-masted sailing vessels** (three-masters)

- 18 three-masted schooner
 19 three-masted topsail schooner
 20 bark (barque) schooner
 21-23 bark (barque) [cf. illustration of rigging and sails in plate 219]

21 foremast**22 mainmast****23 mizzen (mizen) mast****24-27 full-rigged ship**

- 24 mizzen (mizen) mast
 25 crossjack yard (crojack yard)
 26 crossjack (crojack)
 27 ports

28-31 four-masted sailing ships (four-masters)

- 28 four-masted schooner
 29 four-masted bark (barque)
 30 mizzen (mizen) mast
 31 four-masted full-rigged ship

32-34 five-masted bark (barque)

- 32 skysail
 33 middle mast
 34 mizzen (mizen) mast

35-37 development of sailing ships over 400 years

- 35 five-masted full-rigged ship 'Preussen' 1902-10
 36 English clipper ship 'Spindrift' 1867
 37 caravel (carvel) 'Santa Maria' 1492

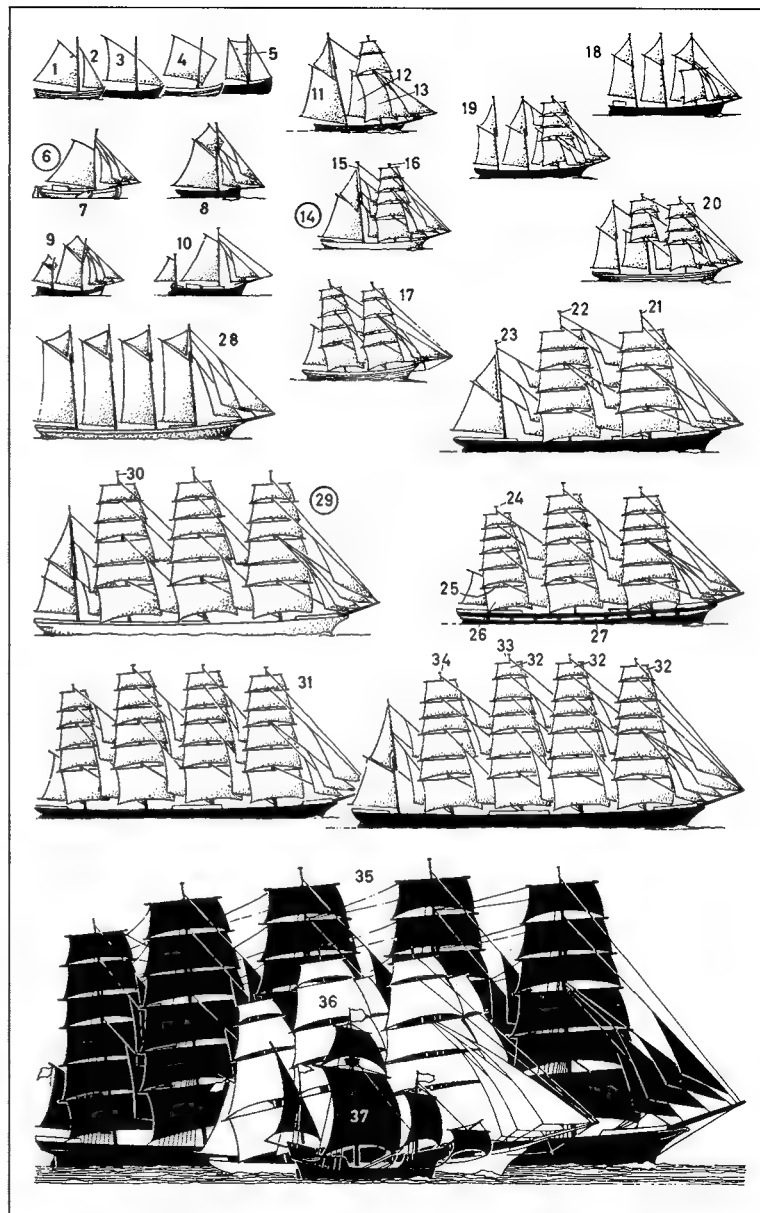

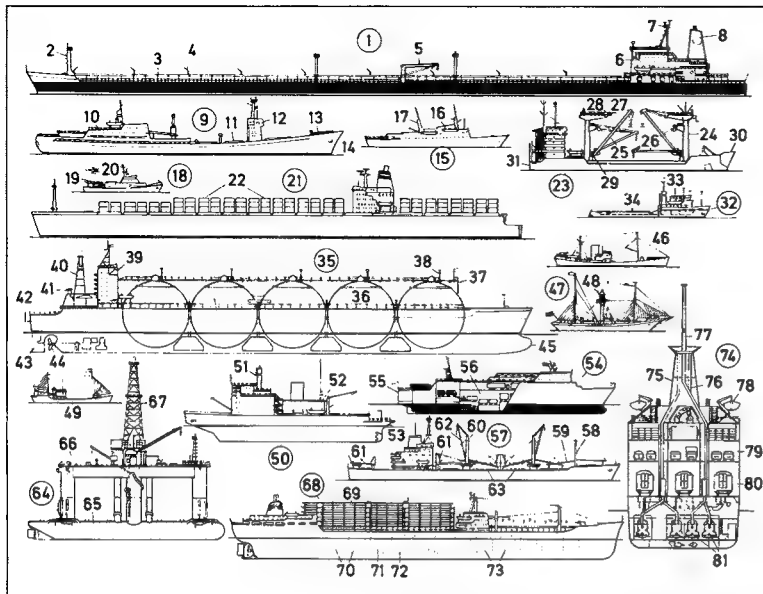

- | | | |
|---|---|--|
| 1 ULCC (ultra-large crude carrier) of the 'all-aft' type | 24-29 cargo gear (cargo-handling gear) | 47 lightship (light vessel) |
| 2 foremast | 24 bipod mast | 48 lantern (characteristic light) |
| 3 catwalk with pipes | 25 jumbo derrick boom (heavy-lift derrick boom) | 49 smack |
| 4 fire gun (fire nozzle) | 26 derrick boom (cargo boom) | 50 ice breaker |
| 5 deck crane | 27 tackle | 51 steaming light mast |
| 6 deckhouse with bridge | 28 block | 52 helicopter hangar |
| 7 aft signal (signalling) and radar mast | 29 thrust bearing | 53 stern towing point, for gripping the bow of ships in tow |
| 8 funnel | 30 bow doors | 54 roll-on-roll-off (ro-ro) trailer ferry |
| 9 nuclear research ship 'Otto Hahn', a bulk carrier | 31 stern loading door | 55 stern port (stern opening) with ramp |
| 10 aft superstructure (engine room) | 32 offshore drilling rig supply vessel | 56 heavy vehicle lifts (<i>Am.</i> heavy vehicle elevators) |
| 11 cargo hatchway for bulk goods (bulk cargoes) | 33 compact superstructure loading deck (working deck) | 57 multi-purpose freighter |
| 12 bridge | 34 liquefied-gas tanker | 58 ventilator-type samson (sampson) post (ventilator-type king post) |
| 13 forecastle (fo'c'sle) | 35 navigational television receiver mast | 59 derrick boom (cargo boom, cargo gear, cargo-handling gear) |
| 14 stem | 36 vent mast | 60 derrick mast |
| 15 seaside pleasure boat | 37 deckhouse | 61 deck crane |
| 16 dummy funnel | 38 funnel | 62 jumbo derrick boom (heavy-lift derrick boom) |
| 17 exhaust mast | 39 ventilator | 63 cargo hatchway |
| 18 rescue cruiser | 40 transom stern (transom) (working deck) | 64 semisubmersible drilling vessel |
| 19 helicopter platform | 41 rudder blade (rudder) | 65 floating vessel with |
| 20 rescue helicopter | 42 ship's propeller (ship's screw) | |
| 21 all-container ship | 43 bulbous bow | |
| 22 containers stowed on deck | 44 steam trawler | |
| 23 cargo ship | | |

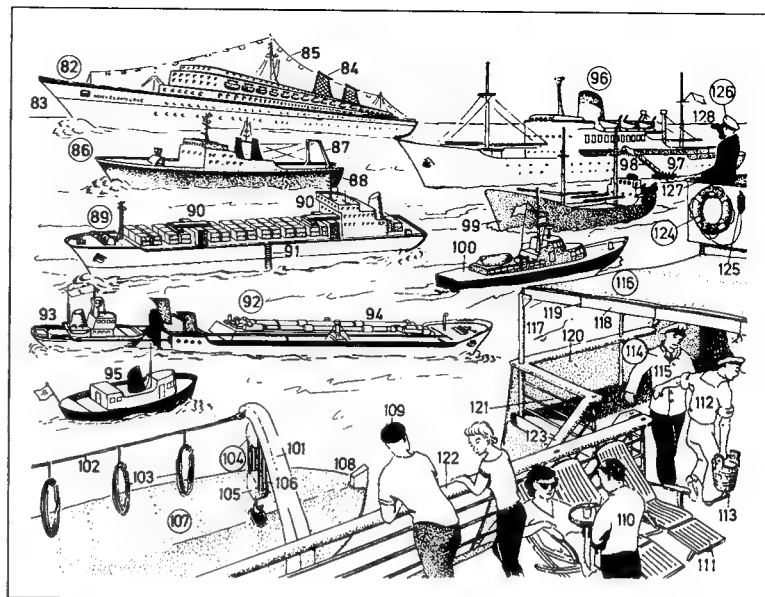

- | | | |
|--|---|---|
| 66 drilling platform | 88 stern ramp | boat) covered with tarpaulin |
| 67 derrick | 89 container ship | 108 stem |
| 68 cattleship (cattle vessel) | 90 loading bridge (loading platform) | 109 passenger |
| 69 superstructure for transporting livestock | 91 sea ladder (jacob's ladder, rope ladder) | 110 steward |
| 70 fresh water tanks | 92 barge and push tug assembly | 111 deck-chair |
| 71 fuel tank | 93 push tug | 112 dock hand |
| 72 dung tank | 94 tug-pushed dumb barge (tug-pushed lighter) | 113 deck bucket |
| 73 fodder tanks | 95 pilot boat | 114 boatswain (bo's'n, bo'sun, bosun) |
| 74 train ferry [cross section] | 96 combined cargo and passenger liner | 115 tunic |
| 75 funnel | 97 passengers disembarking by boat | 116 awning |
| 76 exhaust pipes | 98 accommodation ladder | 117 stanchion |
| 77 mast | 99 coaster (coasting vessel) | 118 ridge rope (jackstay) |
| 78 ship's lifeboat hanging at the davit | 100 customs or police launch | 119 lashing |
| 79 car deck | 101-128 excursion steamer (pleasure steamer) | 120 bulwark |
| 80 main deck (train deck) | 101-106 lifeboat launching gear | 121 guard rail |
| 81 main engines | 101 davit | 122 handrail (top rail) |
| 82 passenger liner (liner, ocean liner) | 102 wire rope span | 123 companion ladder (companionway) |
| 83 stem | 103 lifeline | 124 lifebelt (lifebuoy) |
| 84 funnel with lattice casing | 104 tackle | 125 lifebuoy light (lifebelt light, signal light) |
| 85 flag dressing (rainbow dressing, string of flags extending over mast-heads, e.g., on the maiden voyage) | 105 block | 126 officer of the watch (watchkeeper) |
| 86 trawler , a factory ship | 106 fall | 127 reefer (<i>Am.</i> pea jacket) |
| 87 gallows | 107 ship's lifeboat (ship's | 128 binoculars |

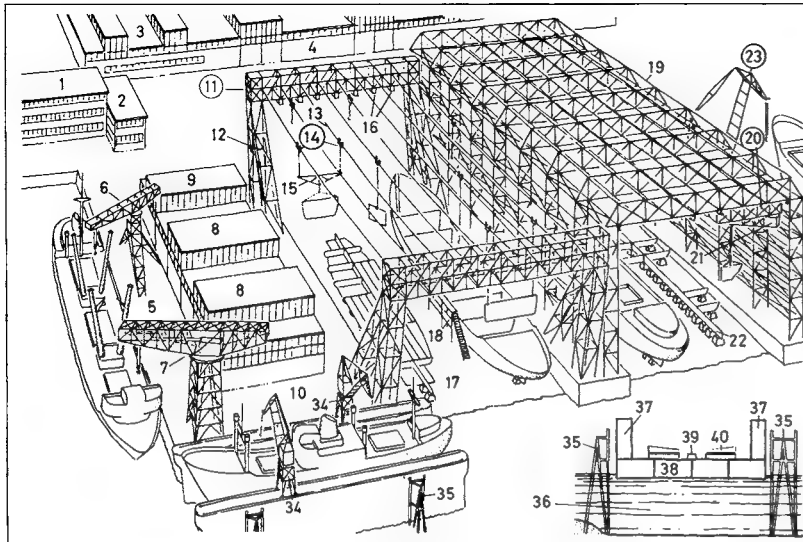

1-43 shipyard (shipbuilding yard, dock-yard, *Am.* navy yard)

- 1 administrative offices
- 2 ship-drawing office
- 3, 4 shipbuilding sheds
- 5 mould (*Am.* mold) loft
- 4 erection shop
- 5-9 fitting-out quay
- 5 quay
- 6 tripod crane
- 7 hammer-headed crane
- 8 engineering workshop
- 9 boiler shop
- 10 repair quay
- 11-26 slipways (slips, building berths, building slips, stocks)
- 11-18 cable crane berth, a slipway (building berth)
- 11 slipway portal
- 12 bridge support
- 13 crane cable
- 14 crab (jenny)
- 15 cross piece
- 16 crane driver's cabin (crane driver's cage)
- 17 slipway floor
- 18 staging, a scaffold
- 19-21 frame slipway

- 19 slipway frame
- 20 overhead travelling (*Am.* traveling) crane (gantry crane)
- 21 slewing crab
- 22 keel in position
- 23 luffing jib crane, a slipway crane
- 24 crane rails (crane track)
- 25 gantry crane
- 26 gantry (bridge)
- 27 trestles (supports)
- 28 crab (jenny)
- 29 hull frames in position
- 30 ship under construction
- 31-33 dry dock
- 31 dock floor (dock bottom)
- 32 dock gates (caisson)
- 33 pumping station (power house)
- 34-43 floating dock (pontoon dock)
- 34 dock crane (dockside crane), a jib crane
- 35 fender pile
- 36-43 working of docks
- 36 dock basin
- 37, 38 dock structure
- 37 side tank (side wall)
- 38 bottom tank (bottom pontoon)
- 39 keel block
- 40 bilge block (bilge shore, side support)

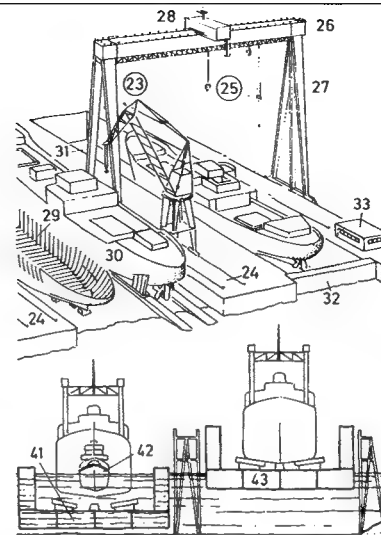

41-43 docking a ship

- 41 flooded floating dock
- 42 tug towing the ship
- 43 emptied (pumped-out) dock
- 44-61 structural parts of the ship
- 44-56 longitudinal structure
- 44-49 shell (shell plating, skin)
- 44 sheer strake
- 45 side strake
- 46 bilge strake
- 47 bilge keel
- 48 bottom plating
- 49 flat plate keel (keel plate)
- 50 stringer (side stringer)
- 51 tank margin plate
- 52 longitudinal side girder
- 53 centre (*Am.* center) plate girder (centre girder, kelson, keelson, vertical keel)
- 54 tank top plating (tank top, inner bottom plating)
- 55 centre (*Am.* center) strake
- 56 deck plating
- 57 deck beam
- 58 frame (rib)
- 59 floor plate
- 60 cellular double bottom
- 61 hold pillar (pillar)

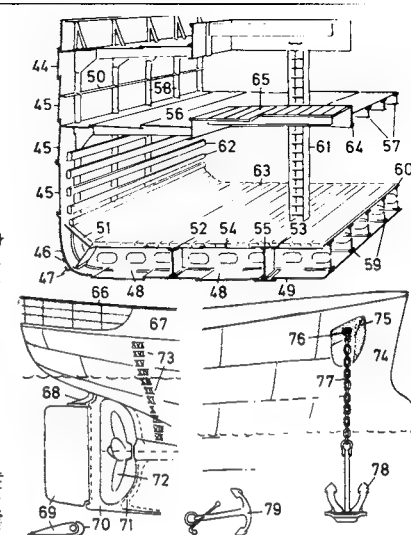

- 62, 63 dunnage
- 62 side battens (side ceiling, spar ceiling)
- 63 ceiling (floor ceiling)
- 64, 65 hatchway
- 64 hatch coaming
- 65 hatch cover (hatchboard)
- 66-72 stern
- 66 guard rail
- 67 bulwark
- 68 rudder stock
- 69, 70 Oertz rudder
- 69 rudder blade (rudder)
- 70, 71 stern frame
- 70 rudder post
- 71 propeller post (screw post)
- 72 ship's propeller (ship's screw)
- 73 draught (draft) marks
- 74-79 bow
- 74 stem, a bulbous stem (bulbous bow)
- 75 hawse
- 76 hawse pipe
- 77 anchor cable (chain cable)
- 78 stockless anchor (patent anchor)
- 79 stocked anchor

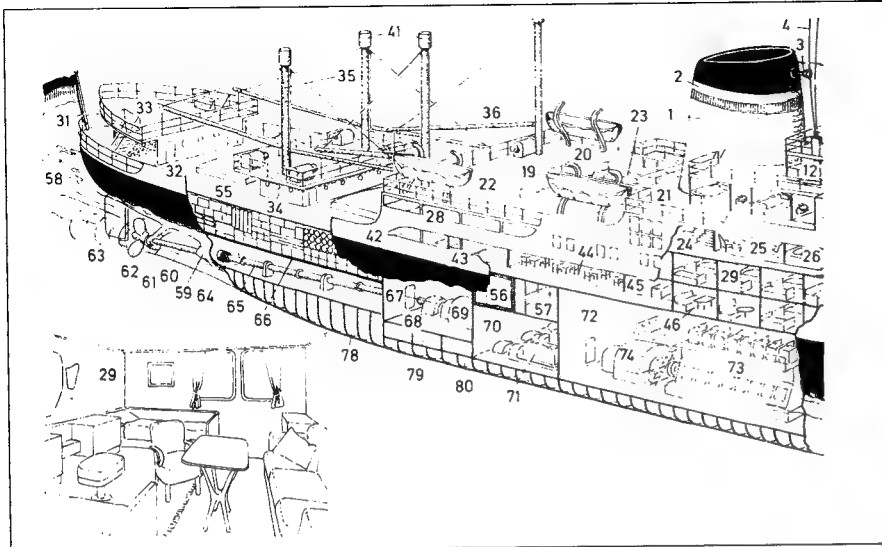

1-71 combined cargo and passenger ship [of the older type]

- 1 funnel
- 2 funnel marking
- 3 siren (fog horn)
- 4-11 compass platform** (compass bridge, compass flat, monkey bridge)
- 4 antenna lead-in (antenna down-lead)
- 5 radio direction finder (RDF) antenna (direction finder antenna, rotatable loop antenna, aural null loop antenna)
- 6 magnetic compass (mariner's compass)
- 7 morse lamp (signalling, *Am.* signalling, lamp)
- 8 radar antenna (radar scanner)
- 9 code flag signal
- 10 code flag halyards
- 11 triatic stay (signal stay)
- 12-18 bridge deck** (bridge)
- 12 radio room
- 13 captain's cabin
- 14 navigating bridge
- 15 starboard sidelight [green; port sidelight red]
- 16 wing of bridge
- 17 shelter (weather cloth, dodger)
- 18 wheelhouse
- 19-21 boat deck**
- 19 ship's lifeboat
- 20 davit
- 21 officer's cabin
- 22-27 promenade deck**
- 22 sun deck (lido deck)
- 23 swimming pool
- 24 companion ladder (companionway)
- 25 library (ship's library)
- 26 lounge
- 27 promenade
- 28-30 A-deck**
- 28 semi-enclosed deck space
- 29 double-berth cabin, a cabin
- 30 de luxe cabin
- 31 ensign staff
- 32-47 B-deck** (main deck)
- 32 after deck
- 33 poop
- 34 deckhouse
- 35 samson (sampson) post (king post)
- 36 derrick boom (cargo boom)
- 37 crosstrees (spreader)
- 38 crow's nest
- 39 topmast
- 40 forward steaming light

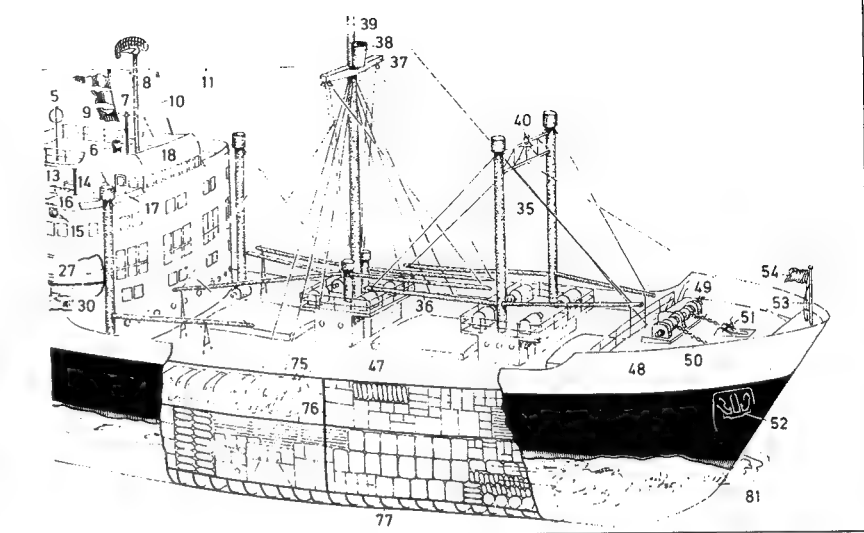

- 41 ventilator lead
- 42 galley (caboose, cookroom, ship's kitchen)
- 43 ship's pantry
- 44 dining room
- 45 purser's office
- 46 single-berth cabin
- 47 foredeck
- 48 forecastle (fo'c'sle)
- 49-51 ground tackle**
- 49 windlass
- 50 anchor cable (chain cable)
- 51 compressor (chain compressor)
- 52 anchor
- 53 jackstaff
- 54 jack
- 55 after holds
- 56 cold storage room (insulated hold)
- 57 store room
- 58 wake
- 59 shell bossing (shaft bossing)
- 60 tail shaft (tail end shaft)
- 61 shaft strut (strut, spectacle frame, propeller strut, propeller bracket)
- 62 three-blade ship's propeller (ship's screw)
- 63 rudder blade (rudder)
- 64 stuffing box
- 65 propeller shaft
- 66 shaft alley (shaft tunnel)
- 67 thrust block
- 68-74 diesel-electric drive**
- 68 electric engine room
- 69 electric motor
- 70 auxiliary engine room
- 71 auxiliary engines
- 72 main engine room
- 73 main engine, a diesel engine
- 74 generator
- 75 forward holds
- 76 tween deck
- 77 cargo
- 78 ballast tank (deep tank) for water ballast
- 79 fresh water tank
- 80 fuel tank
- 81 bow wave

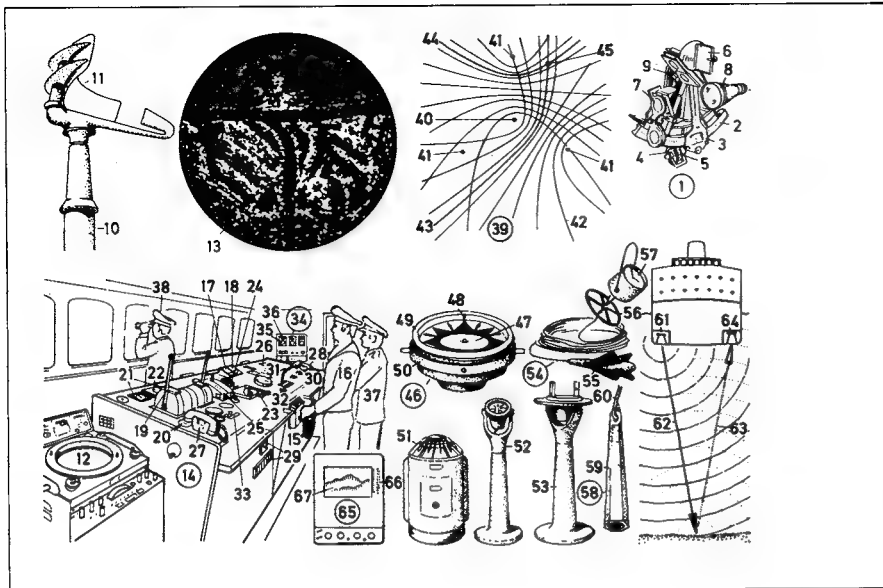

- | | | |
|--|--|--|
| 1 sextant | 21 main engine revolution indicator | 37 navigating officer |
| 2 graduated arc | 22 ship's speedometer (log) | 38 captain |
| 3 index bar (index arm) | 23 control switch for bow thruster (bow-maneuvring, <i>Am.</i> maneuvering, propeller) | 39 Decca navigation system |
| 4 decimal micrometer | 24 echo recorder (depth recorder, echograph) | 40 master station |
| 5 vernier | 25 engine telegraph (engine order telegraph) | 41 slave station |
| 6 index mirror | 26 controls for the anti-rolling system (for the stabilizers) | 42 null hyperbola |
| 7 horizon glass (horizon mirror) | 27 local-battery telephone | 43 hyperbolic position line 1 |
| 8 telescope | 28 shipping traffic radio telephone | 44 hyperbolic position line 2 |
| 9 grip (handgrip) | 29 navigation light indicator panel (running light indicator panel) | 45 position (fix, ship fix) |
| 10-13 radar equipment (radar apparatus) | 30 microphone for ship's address system | 46-53 compasses |
| 10 radar pedestal | 31 gyro compass (gyroscopic compass), a compass repeater | 46 liquid compass (fluid compass, spirit compass, wet compass), a magnetic compass |
| 11 revolving radar reflector | 32 control button for the ship's siren (ship's fog horn) | 47 compass card |
| 12 radar display unit (radar screen) | 33 main engine overload indicator | 48 lubber's line (lubber's mark, lubber's point) |
| 13 radar image (radar picture) | 34 Decca position-finder (Decca Navigator) | 49 compass bowl |
| 14-38 wheelhouse | 35 rough focusing indicator | 50 gimbal ring |
| 14 steering and control position | 36 fine focusing indicator | 51-53 gyro compass (gyroscopic compass, gyro compass unit) |
| 15 ship's wheel for controlling the rudder mechanism | | 51 master compass (master gyro compass) |
| 16 helmsman (<i>Am.</i> wheelman) | | 52 compass repeater (gyro repeater) |
| 17 rudder angle indicator | | 53 compass repeater with pelorus |
| 18 automatic pilot (autopilot) | | 54 patent log (screw log, mechanical log, towing log, taffrail log, speedometer) |
| 19 control lever for the variable-pitch propeller (reversible propeller, feathering propeller, feathering screw) | | 55 rotator |
| 20 propeller pitch indicator | | 56 governor |

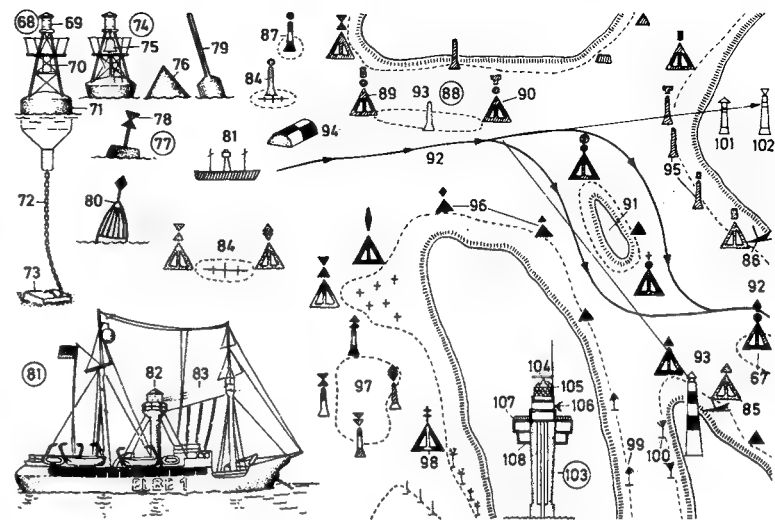

- | | | |
|---|--|---|
| 57 log clock | 77 can buoy | 96 starboard hand buoys (starboard hand marks) [black] |
| 58-67 leads | 78 topmark | 97 shoals (shallows, shallow water, <i>Am.</i> flats) outside the fairway |
| 58 hand lead | 79 spar buoy | 98 middle of the fairway (mid-channel) |
| 59 lead (lead sinker) | 80 topmark buoy | 99 starboard markers [inverted broom] |
| 60 leadline | 81 lightship (light vessel) | 100 port markers [upward-pointing broom] |
| 61-67 echo sounder (echo sounding machine) | 82 lantern mast (lantern tower) | 101, 102 range lights (leading lights) |
| 61 sound transmitter | 83 beam of light | 101 lower range light (lower leading light) |
| 62 sound wave (sound impulse) | 84-102 fairway markings (channel markings) | 102 higher range light (higher leading light) |
| 63 echo (sound echo, echo signal) | 84 wreck [green buoys] | 103 lighthouse |
| 64 echo receiver (hydrophone) | 85 wreck to starboard | 104 radar antenna (radar scanner) |
| 65 echograph (echo sounding machine recorder) | 86 wreck to port | 105 lantern (characteristic light) |
| 66 depth scale | 87 shoals (shallows, shallow water, <i>Am.</i> flats) | 106 radio direction finder (RDF) antenna |
| 67 echogram (depth recording, depth reading) | 88 middle ground to port division (bifurcation) [beginning of the middle ground; topmark: red cylinder above red ball] | 107 machinery and observation platform (machinery and observation deck) |
| 68-108 sea marks (floating navigational marks) for buoyage and lighting systems | 89 convergence (confluence) [end of the middle ground; topmark: red St. Antony's cross above red ball] | 108 living quarters |
| 68-83 fairway marks (channel marks) | 90 middle ground to port division | |
| 68 light and whistle buoy | 91 middle ground to port division | |
| 69 light (warning light) | 92 main fairway (main navigable channel) | |
| 70 whistle | 93 secondary fairway (secondary navigable channel) | |
| 71 buoy | 94 can buoy | |
| 72 mooring chain | 95 port hand buoys (port hand marks) [red] | |
| 73 sinker (mooring sinker) | | |
| 74 light and bell buoy | | |
| 75 bell | | |
| 76 conical buoy | | |

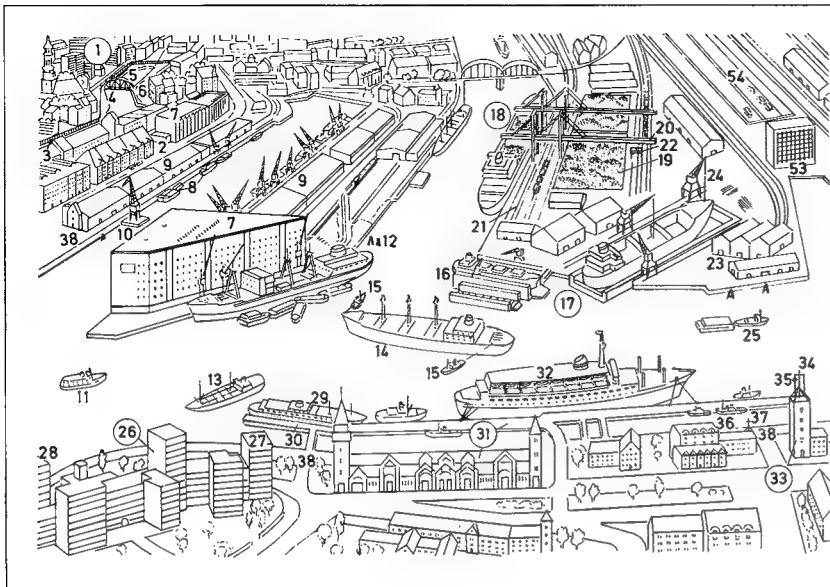

- | | |
|--|---|
| 1 dock area | 18 coal wharf |
| 2 free port (foreign trade zone) | 19 coal bunker |
| 3 free zone frontier (free zone enclosure) | 20 transporter loading bridge |
| 4 customs barrier | 21 quayside railway |
| 5 customs entrance | 22 weighing bunker |
| 6 port custom house | 23 warehouse |
| 7 entrepôt | 24 quayside crane |
| 8 barge (dumb barge, lighter) | 25 launch and lighter |
| 9 break-bulk cargo transit shed (general cargo transit shed, package cargo transit shed) | 26 port hospital |
| 10 floating crane | 27 quarantine wing |
| 11 harbour (Am. harbor) ferry (ferry-boat) | 28 Institute of Tropical Medicine |
| 12 fender (dolphin) | 29 excursion steamer (pleasure steamer) |
| 13 bunkering boat | 30 jetty |
| 14 break-bulk carrier (general cargo ship) | 31 passenger terminal |
| 15 tug | 32 liner (passenger liner, ocean liner) |
| 16 floating dock (pontoon dock) | 33 meteorological office, a weather station |
| 17 dry dock | 34 signal mast (signalling mast) |
| | 35 storm signal |
| | 36 port administration offices |
| | 37 tide level indicator |
| | 38 quayside road (quayside roadway) |

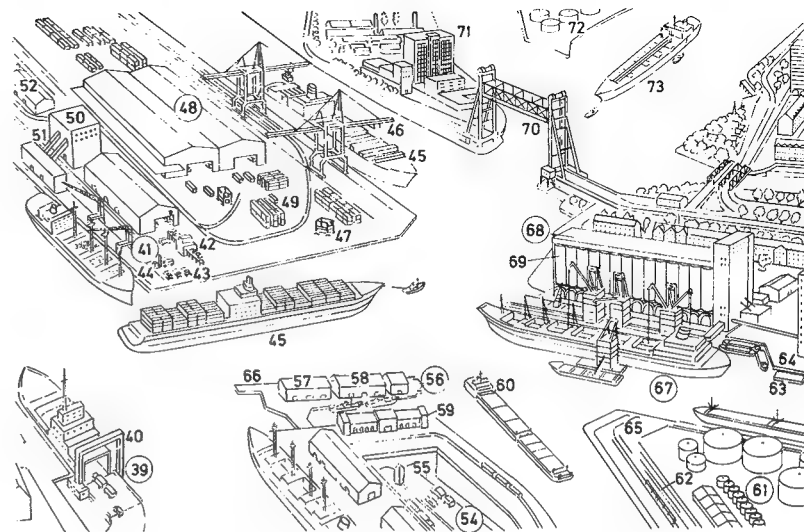

- | | |
|---|------------------------------------|
| 39 roll-on roll-off (ro-ro) system (roll-on roll-off operation) | 57 fish market |
| 40 gantry | 58 auction room |
| 41 truck-to-truck system (truck-to-truck operation) | 59 fish-canning factory |
| 42 foil-wrapped unit loads | 60 push tow |
| 43 pallets | 61 tank farm |
| 44 forklift truck (fork truck, forklift) | 62 railway siding |
| 45 container ship | 63 landing pontoon (landing stage) |
| 46 transporter container-loading bridge | 64 quay |
| 47 container carrier truck | 65 breakwater (mole) |
| 48 container terminal (container berth) | 66 pier (jetty), a quay extension |
| 49 unit load | 67 bulk carrier |
| 50 cold store | 68 silo |
| 51 conveyor belt (conveyor) | 69 silo cylinder |
| 52 fruit storage shed (fruit warehouse) | 70 lift bridge |
| 53 office building | 71 industrial plant |
| 54 urban motorway (Am. freeway) | 72 storage tanks |
| 55 harbour (Am. harbor) tunnels | 73 tanker |
| 56 fish dock | |

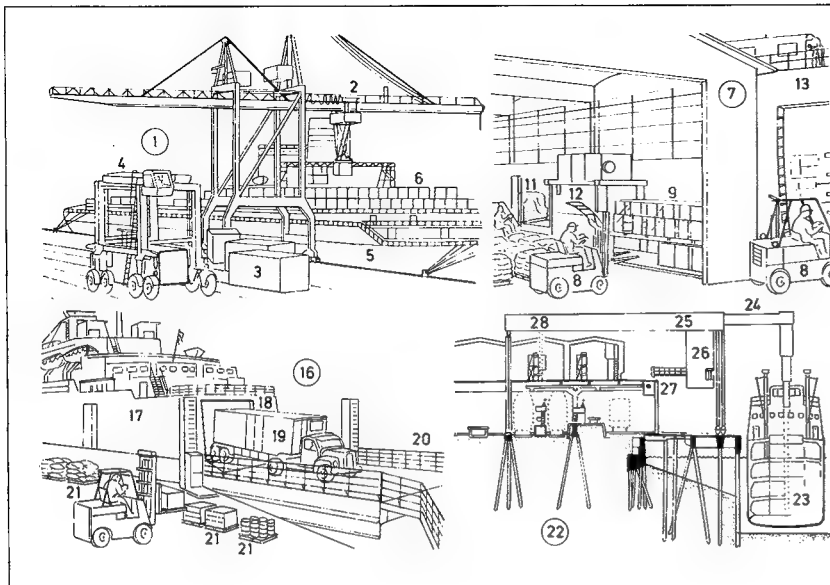

- | | |
|--|---|
| 1 container terminal (container berth), ■ modern cargo-handling berth | 17 roll-on roll-off ship (ro-ro-ship) |
| 2 transporter container-loading bridge (loading bridge); <i>sim.</i> : transtainer crane (transtainer) | 18 stern port (stern opening) |
| 3 container | 19 driven load, a lorry (<i>Am.</i> truck) |
| 4 truck (carrier) | 20 ro-ro depot |
| 5 all-container ship | 21 unitized load (unitized package) |
| 6 containers stowed on deck | 22 banana-handling terminal [section] |
| 7 truck-to-truck handling (horizontal cargo handling with pallets) | 23 seaward tumbler |
| 8 forklift truck (fork truck, forklift) | 24 jib |
| 9 unitized foil-wrapped load (unit load) | 25 elevator bridge |
| 10 flat pallet, a standard pallet | 26 chain sling |
| 11 unitized break-bulk cargo | 27 lighting station |
| 12 heat sealing machine | 28 shore-side tumbler for loading trains and lorries (<i>Am.</i> trucks) |
| 13 break-bulk carrier (general cargo ship) | |
| 14 cargo hatchway | |
| 15 receiving truck on board ship | |
| 16 multi-purpose terminal | |

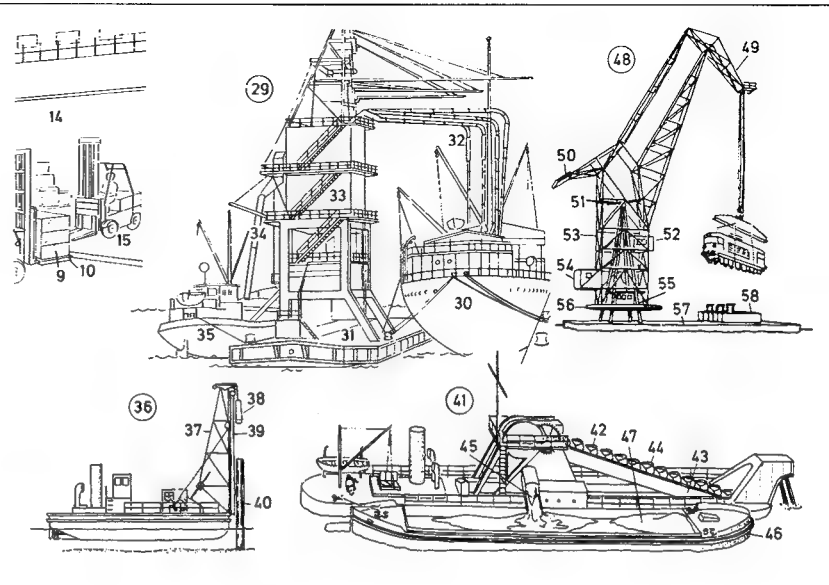

- | | |
|---------------------------------|---|
| 29 bulk cargo handling | 52 crane driver's cabin (crane driver's cage) |
| 30 bulk carrier | 53 crane framework |
| 31 floating bulk-cargo elevator | 54 winch house |
| 32 suction pipes | 55 control platform |
| 33 receiver | 56 turntable |
| 34 delivery pipe | 57 pontoon, a pram |
| 35 bulk transporter barge | 58 engine superstructure (engine mounting) |
| 36 floating pile driver | |
| 37 pile driver frame | |
| 38 pile hammer | |
| 39 driving guide rail | |
| 40 pile | |
| 41 bucket dredger, a dredger | |
| 42 bucket chain | |
| 43 bucket ladder | |
| 44 dredger bucket | |
| 45 chute | |
| 46 hopper barge | |
| 47 spoil | |
| 48 floating crane | |
| 49 jib (boom) | |
| 50 counterweight (counterpoise) | |
| 51 adjusting spindle | |

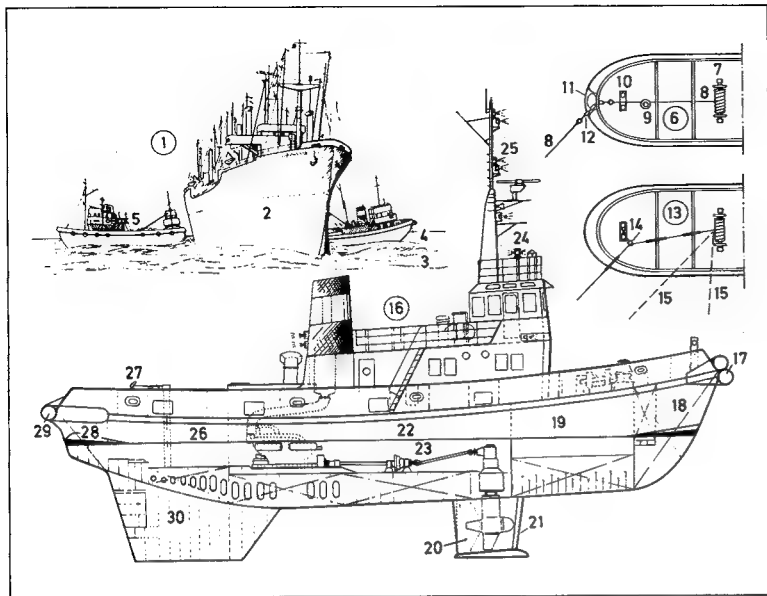

- | | |
|---|---|
| 1 salvaging (salving) of a ship run aground | 18 forepeak |
| 2 ship run aground (damaged vessel) | 19 living quarters |
| 3 sandbank; <i>also</i> : quicksand | 20 Schottel propeller |
| 4 open sea | 21 Kort vent |
| 5 tug (salvage tug) | 22 engine and propeller room |
| 6-15 towing gear | 23 clutch coupling |
| 6 towing gear for towing at sea | 24 compass platform (compass bridge, compass flat, monkey bridge) |
| 7 towing winch (towing machine, towing engine) | 25 fire-fighting equipment |
| 8 tow rope (tow line, towing hawser) | 26 stowage |
| 9 tow rope guide | 27 tow hook |
| 10 cross-shaped bollard | 28 afterpeak |
| 11 hawse hole | 29 stern fender |
| 12 anchor cable (chain cable) | 30 main manoeuvring (<i>Am.</i> manoeuvring) keel |
| 13 towing gear for work in harbours (<i>Am.</i> harbors) | |
| 14 guest rope | |
| 15 position of the tow rope (tow line, towing hawser) | |
| 16 tug (salvage tug) [vertical elevation] | |
| 17 bow fender (pudding fender) | |

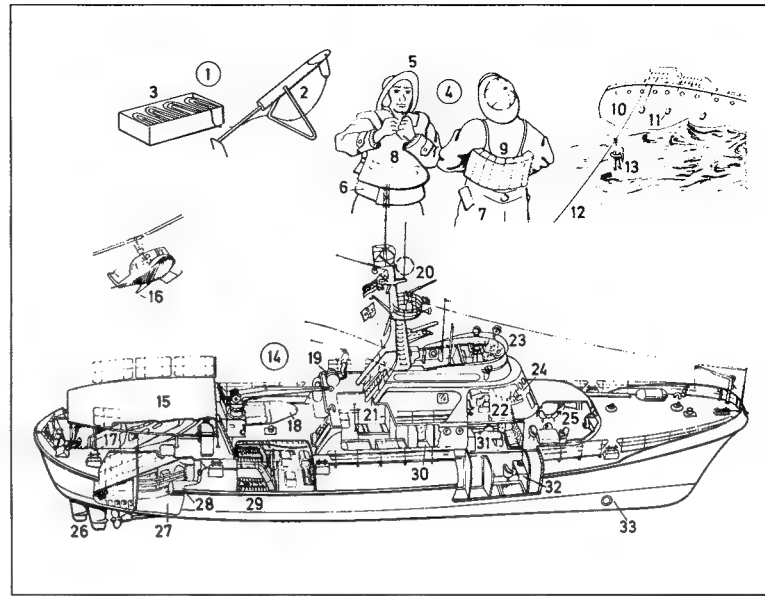

- | | |
|--|---|
| 1 rocket apparatus (rocket gun, line-throwing gun) | 21 hospital unit with operating cabin and exposure bath |
| 2 life rocket (rocket) | 22 navigating bridge |
| 3 rocket line (whip line) | 23 upper tier of navigating bridge |
| 4 oilskins | 24 lower tier of navigating bridge |
| 5 sou'wester (southwester) | 25 messroom |
| 6 oilskin jacket | 26 rudders and propeller (screw) |
| 7 oilskin coat | 27 stowage |
| 8 inflatable life jacket | 28 foam can |
| 9 cork life jacket (cork life preserver) | 29 side engines |
| 10 stranded ship (damaged vessel) | 30 shower |
| 11 oil bag, for trickling oil on the water surface | 31 coxswain's cabin |
| 12 lifeline | 32 crew member's single-berth cabin |
| 13 breeches buoy | 33 bow propeller |
| 14 rescue cruiser | |
| 15 helicopter landing deck | |
| 16 rescue helicopter | |
| 17 daughter boat | |
| 18 inflatable boat (inflatable dinghy) | |
| 19 life raft | |
| 20 fire-fighting equipment for fires at sea | |

1-14 wing configurations

- 1 high-wing monoplane (high-wing plane)
- 2 span (wing span)
- 3 shoulder-wing monoplane (shoulder-wing plane)
- 4 midwing monoplane (midwing plane)
- 5 low-wing monoplane (low-wing plane)
- 6 triplane
- 7 upper wing
- 8 middle wing (central wing)
- 9 lower wing
- 10 biplane
- 11 strut
- 12 cross bracing wires
- 13 sesquiplane
- 14 low-wing monoplane (low-wing plane) with cranked wings (inverted gull wings)

15-22 wing shapes

- 15 elliptical wing
- 16 rectangular wing
- 17 tapered wing
- 18 crescent wing
- 19 delta wing
- 20 swept-back wing with semi-positive sweepback
- 21 swept-back wing with positive sweepback
- 22 ogival wing (ogee wing)

23-36 tail shapes (tail unit shapes, empennage shapes)

- 23 normal tail (normal tail unit)
- 24, 25 vertical tail (vertical stabilizer and rudder)
- 24 vertical stabilizer (vertical fin, tail fin)
- 25 rudder
- 26, 27 horizontal tail
- 26 tailplane (horizontal stabilizer)
- 27 elevator
- 28 cruciform tail (cruciform tail unit)
- 29 T-tail (T-tail unit)
- 30 lobe

- 31 V-tail (vee-tail, butterfly tail)
- 32 double tail unit (twin tail unit)
- 33 end plate
- 34 double tail unit (twin tail unit) of a twin-boom aircraft
- 35 raised horizontal tail with double booms
- 36 triple tail unit
- 37 system of flaps
- 38 extensible slat
- 39 spoiler
- 40 double-slotted Fowler flap
- 41 outer aileron (low-speed aileron)
- 42 inner spoiler (landing flap, lift dump)
- 43 inner aileron (all-speed aileron)
- 44 brake flap (air brake)
- 45 basic profile
- 46-48 plain flaps (simple flaps)
- 46 normal flap
- 47 slotted flap
- 48 double-slotted flap
- 49, 50 split flaps
- 49 plain split flap (simple split flap)
- 50 zap flap
- 51 extending flap
- 52 Fowler flap
- 53 slat
- 54 profiled leading-edge flap (droop flap)
- 55 Krüger flap

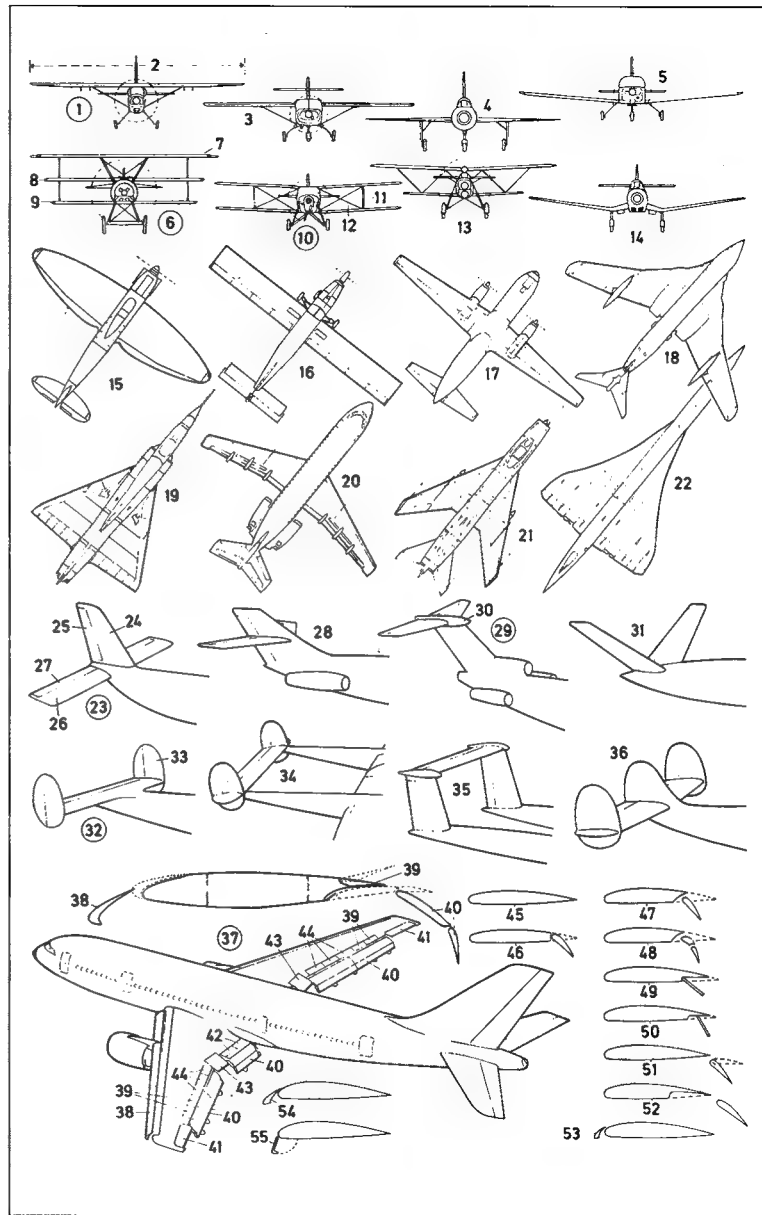

230 Aircraft II

1-31 cockpit of a single-engine (single-engined) racing and passenger aircraft (racing and passenger plane)

- 1 instrument panel
- 2 air-speed (*Am.* airspeed) indicator
- 3 artificial horizon (gyro horizon)
- 4 altimeter
- 5 radio compass (automatic direction finder)
- 6 magnetic compass
- 7 boost gauge (*Am.* gage)
- 8 tachometer (rev counter, revolution counter)
- 9 cylinder temperature gauge (*Am.* gage)
- 10 accelerometer
- 11 chronometer
- 12 turn indicator with ball
- 13 directional gyro
- 14 vertical speed indicator (rate-of-climb indicator, variometer)
- 15 VOR radio direction finder [*VOR: very high frequency omnidirectional range*]
- 16 left tank fuel gauge (*Am.* gage)
- 17 right tank fuel gauge (*Am.* gage)
- 18 ammeter
- 19 fuel pressure gauge (*Am.* gage)
- 20 oil pressure gauge (*Am.* gage)
- 21 oil temperature gauge (*Am.* gage)
- 22 radio and radio navigation equipment
- 23 map light
- 24 wheel (control column, control stick) for operating the ailerons and elevators
- 25 co-pilot's wheel
- 26 switches
- 27 rudder pedals
- 28 co-pilot's rudder pedals
- 29 microphone for the radio
- 30 throttle lever (throttle control)
- 31 mixture control

32-66 single-engine (single-engined) racing and passenger aircraft (racing and passenger plane)

- 32 propeller (airscrew)
- 33 spinner
- 34 flat four engine
- 35 cockpit

- 36 pilot's seat
 - 37 co-pilot's seat
 - 38 passenger seats
 - 39 hood (canopy, cockpit hood, cockpit canopy)
 - 40 steerable nose wheel
 - 41 main undercarriage unit (main landing gear unit)
 - 42 step
 - 43 wing
 - 44 right navigation light (right position light)
 - 45 spar
 - 46 rib
 - 47 stringer (longitudinal reinforcing member)
 - 48 fuel tank
 - 49 landing light
 - 50 left navigation light (left position light)
 - 51 electrostatic conductor
 - 52 aileron
 - 53 landing flap
 - 54 fuselage (body)
 - 55 frame (former)
 - 56 chord
 - 57 stringer (longitudinal reinforcing member)
 - 58 vertical tail (vertical stabilizer and rudder)
 - 59 vertical stabilizer (vertical fin, tail fin)
 - 60 rudder
 - 61 horizontal tail
 - 62 tailplane (horizontal stabilizer)
 - 63 elevator
 - 64 warning light (anticollision light)
 - 65 dipole antenna
 - 66 long-wire antenna (long-conductor antenna)
- 67-72 principal manoeuvres (*Am.* manoeuvres) of the aircraft (aeroplane, plane, *Am.* airplane)**
- 67 pitching
 - 68 lateral axis
 - 69 yawing
 - 70 vertical axis (normal axis)
 - 71 rolling
 - 72 longitudinal axis

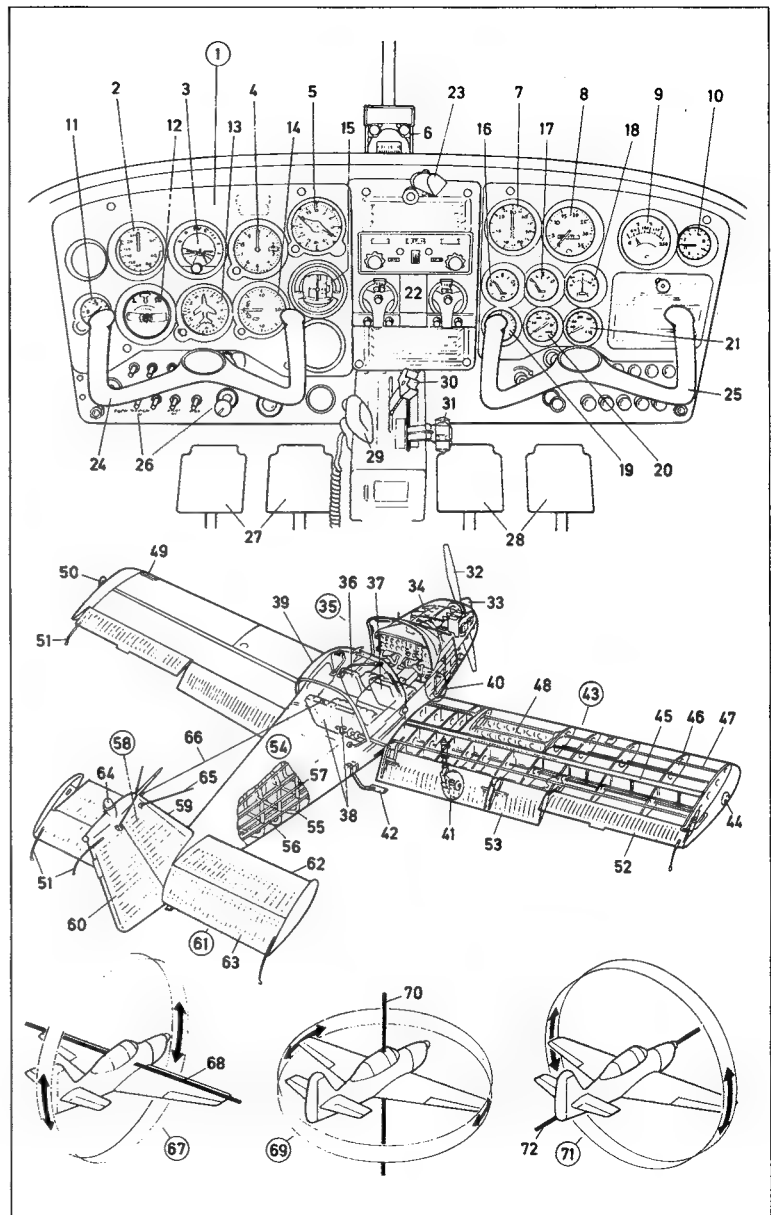

231 Aircraft III

1-33 types of aircraft (aeroplanes, planes, *Am.* airplanes)

1-6 propeller-driven aircraft (aeroplanes, planes, *Am.* airplanes)

1 single-engine (single-engined) racing and passenger aircraft (racing and passenger plane), a low-wing monoplane (low-wing plane)

2 single-engine (single-engined) passenger aircraft, a high-wing monoplane (high-wing plane)

3 twin-engine (twin-engined) business and passenger aircraft (business and passenger plane)

4 short/medium haul airliner, a turboprop plane (turbopropeller plane, propeller-turbine plane)

5 turboprop engine (turbopropeller engine)

6 vertical stabilizer (vertical fin, tail fin)

7-33 jet planes (jet aeroplanes, jets, *Am.* jet airplanes)

7 twin-jet business and passenger aircraft (business and passenger plane)

8 fence

9 wing-tip tank (tip tank)

10 rear engine

11 twin-jet short/medium haul airliner

12 tri-jet medium haul airliner

13 four-jet long haul airliner

14 wide-body long haul airliner (jumbo jet)

15 supersonic airliner [*Concorde*]

16 droop nose

17 twin-jet wide-body airliner for short/medium haul routes (airbus)

18 radar nose (radome, radar dome) with weather radar antenna

19 cockpit

20 galley

21 cargo hold (hold, underfloor hold)

22 passenger cabin with passenger seats

23 retractable nose undercarriage unit (retractable nose landing gear unit)

24 nose undercarriage flap (nose gear flap)

25 centre (*Am.* center) passenger door

26 engine pod with engine (turbojet engine, jet turbine engine, jet engine, jet turbine)

27 electrostatic conductors

28 retractable main undercarriage unit (retractable main landing gear unit)

29 side window

30 rear passenger door

31 toilet (lavatory, WC)

32 pressure bulkhead

33 auxiliary engine (auxiliary gas turbine) for the generator unit

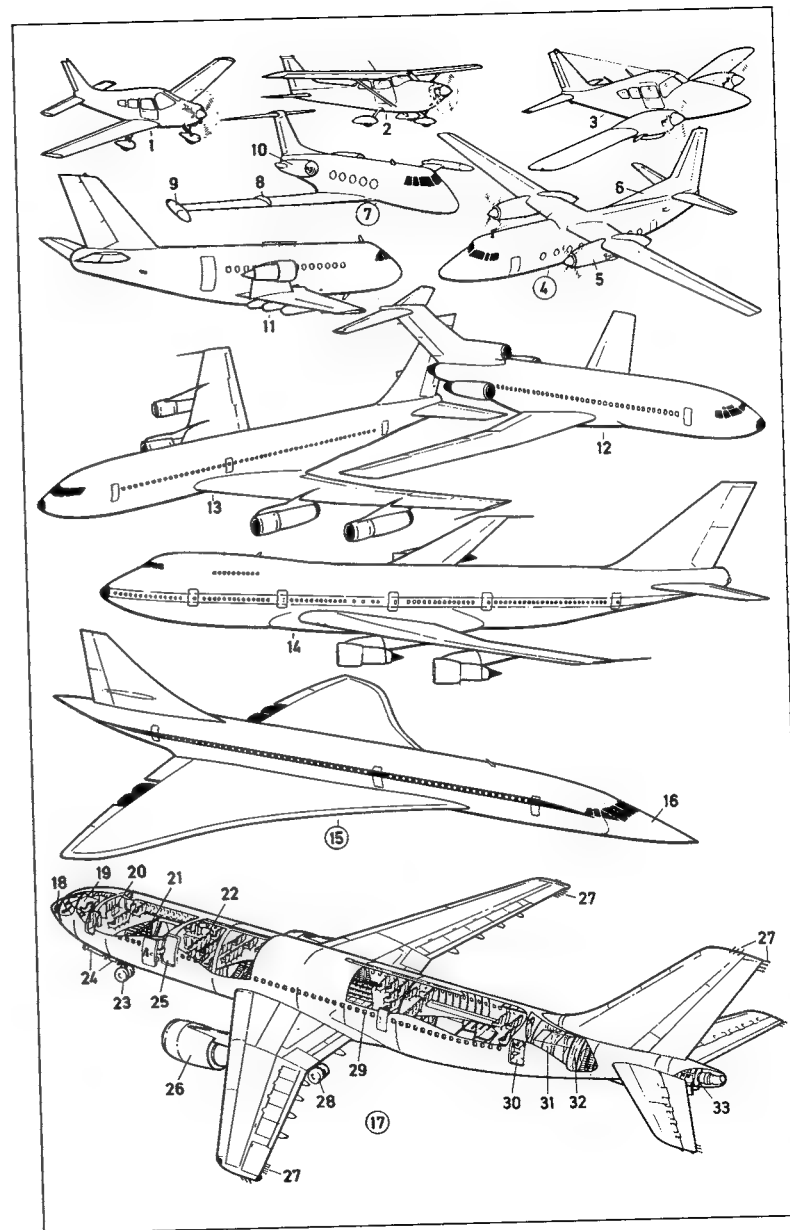

- 1 flying boat, a seaplane
 2 hull
 3 stub wing (sea wing)
 4 tail bracing wires
 5 floatplane (float seaplane), a seaplane
 6 float
 7 vertical stabilizer (vertical fin, tail fin)
 8 amphibian (amphibian flying boat)
 9 hull
 10 retractable undercarriage (retractable landing gear)
11-25 helicopters
 11 light multirole helicopter
 12, 13 main rotor
 12 rotary wing (rotor blade)
 13 rotor head
 14 tail rotor (anti-torque rotor)
 15 landing skids
 16 flying crane
 17 turbine engines
 18 lifting undercarriage
 19 lifting platform
 20 reserve tank
 21 transport helicopter
 22 rotors in tandem
 23 rotor pylon
 24 turbine engine
 25 tail loading gate
26-32 V/STOL aircraft (vertical/short take-off and landing aircraft)
 26 tilt-wing aircraft, a VTOL aircraft (vertical take-off and landing aircraft)
 27 tilt wing in vertical position
 28 contrarotating tail propellers
 29 gyrodyne
 30 turboprop engine (turbopropeller engine)
 31 convertiplane
 32 tilting rotor in vertical position
33-60 aircraft engines (aero engines)
 33-50 jet engines (turbojet engines, jet turbine engines, jet turbines)
 33 front fan-jet

- 34 fan
 35 low-pressure compressor
 36 high-pressure compressor
 37 combustion chamber
 38 fan-jet turbine
 39 nozzle (propelling nozzle, propulsion nozzle)
 40 turbines
 41 bypass duct
 42 aft fan-jet
 43 fan
 44 bypass duct
 45 nozzle (propelling nozzle, propulsion nozzle)
 46 bypass engine
 47 turbines
 48 mixer
 49 nozzle (propelling nozzle, propulsion nozzle)
 50 secondary air flow (bypass air flow)
 51 turboprop engine (turbopropeller engine), a twin-shaft engine
 52 annular air intake
 53 high-pressure turbine
 54 low-pressure turbine
 55 nozzle (propelling nozzle, propulsion nozzle)
 56 shaft
 57 intermediate shaft
 58 gear shaft
 59 reduction gear
 60 propeller shaft

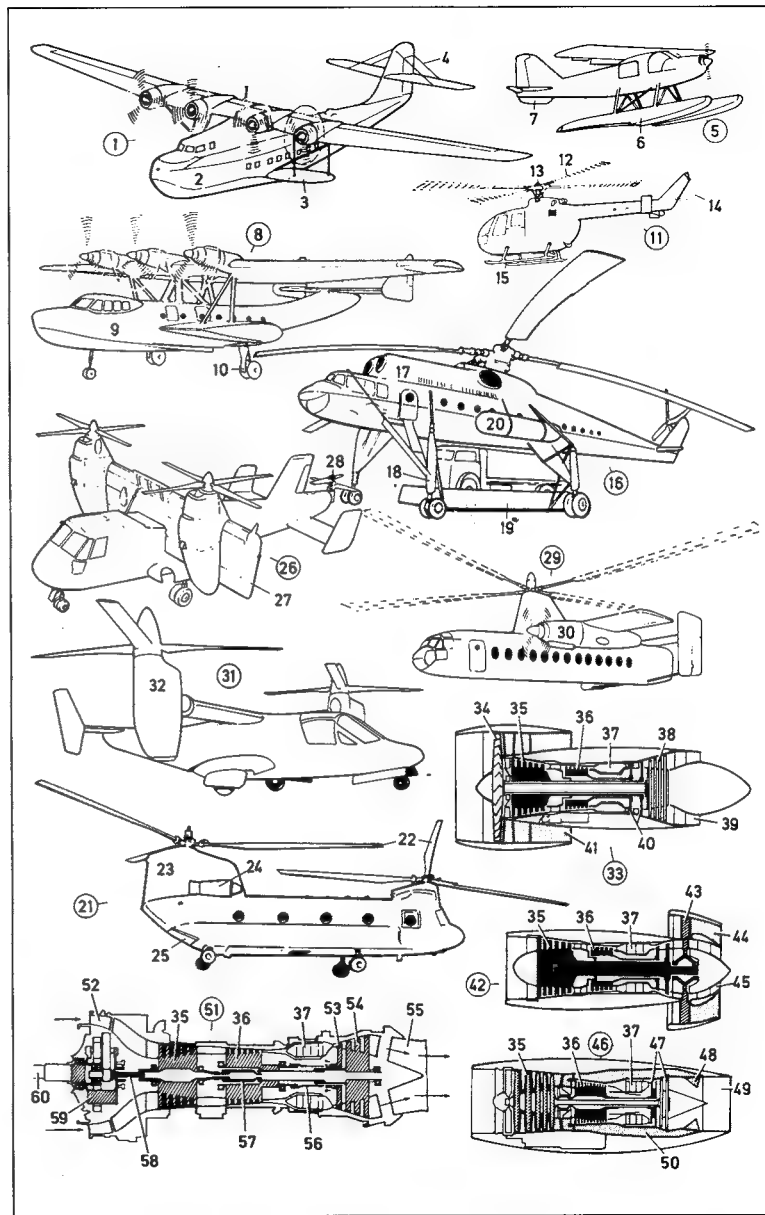

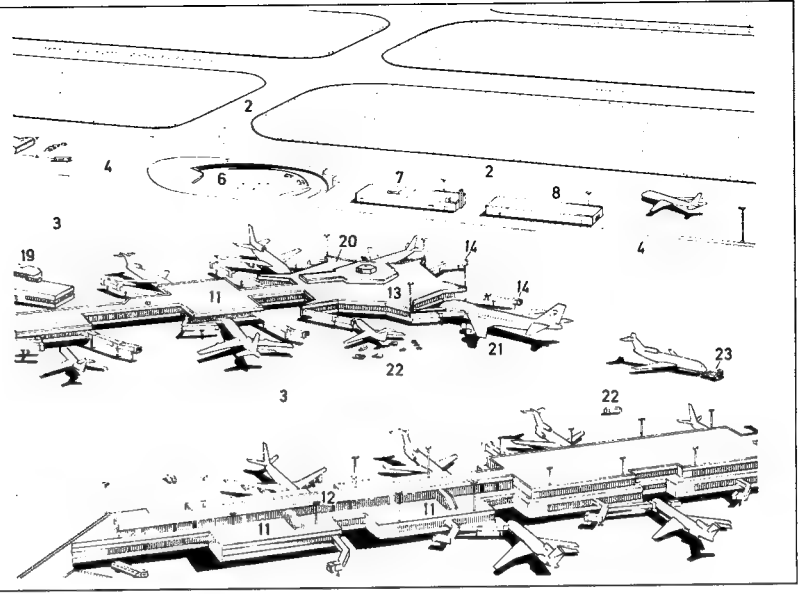
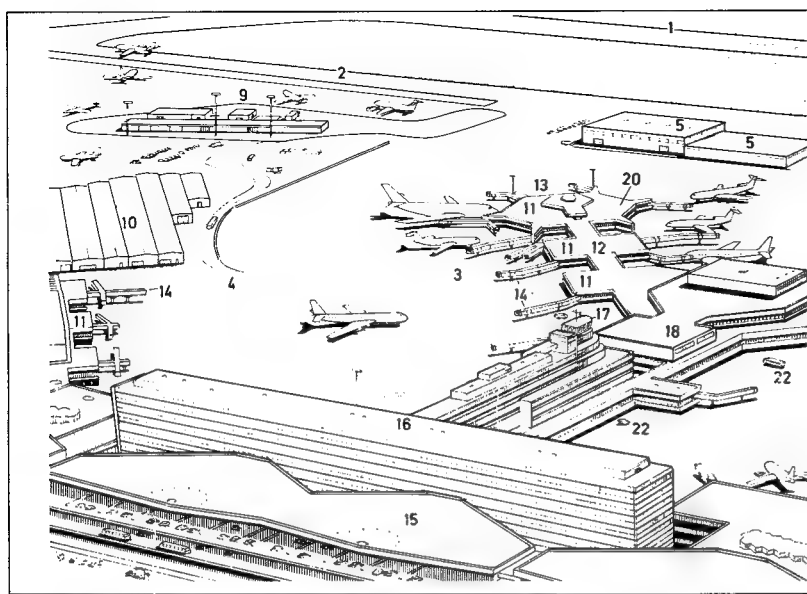

- | | | |
|--|---|--|
| 1 runway | 22 service vehicles, e.g. baggage loaders, water tankers, galley loaders, toilet-cleaning vehicles, ground power units, tankers | 35 'buses' |
| 2 taxiway | 23 aircraft tractor (aircraft tug) | 36 'entrance' |
| 3 apron | 24-53 airport information symbols (pictographs) | 37 'exit' |
| 4 apron taxiway | 24 'airport' | 38 'baggage reclaim' |
| 5 baggage terminal | 25 'departures' | 39 'luggage lockers' |
| 6 tunnel entrance to the baggage terminal | 26 'arrivals' | 40 'telephone - emergency calls only' |
| 7 airport fire service | 27 'transit passengers' | 41 'emergency exit' |
| 8 fire appliance building | 28 'waiting room' ('lounge') | 42 'passport check' |
| 9 mail and cargo terminal | 29 'assembly point' ('meeting point', 'rendezvous point') | 43 'press facilities' |
| 10 cargo warehouse | 30 'spectators' terrace' | 44 'doctor' |
| 11 assembly point | 31 'information' | 45 'chemist' (<i>Am.</i> 'drug-gist') |
| 12 pier | 32 'taxis' | 46 'showers' |
| 13 pierhead | 33 'car hire' | 47 'gentlemen's toilet' ('gentlemen') |
| 14 airbridge | 34 'trains' | 48 'ladies' toilet' ('ladies') |
| 15 departure building (terminal) | | 49 'chapel' |
| 16 administration building | | 50 'restaurant' |
| 17 control tower (tower) | | 51 'change' |
| 18 waiting room (lounge) | | 52 'duty free shop' |
| 19 airport restaurant | | 53 'hairdresser' |
| 20 spectators' terrace | | |
| 21 aircraft in loading position (nosed in) | | |



- 1 Saturn V 'Apollo' booster (booster rocket) [overall view]
- 2 Saturn V 'Apollo' booster (booster rocket) [overall sectional view]
- 3 first rocket stage (S-IC)
- 4 F-1 engines
- 5 heat shield (thermal protection shield)
- 6 aerodynamic engine fairings
- 7 aerodynamic stabilizing fins
- 8 stage separation retro-rockets, 8 rockets arranged in 4 pairs
- 9 kerosene (RP-1) tank [capacity: 811,000 litres]
- 10 liquid oxygen (LOX, LO₂) supply lines, total of 5
- 11 anti-vortex system (device for preventing the formation of vortices in the fuel)
- 12 liquid oxygen (LOX, LO₂) tank [capacity: 1,315,000 litres]
- 13 anti-slosh baffles
- 14 compressed-helium bottles (helium pressure bottles)
- 15 diffuser for gaseous oxygen
- 16 inter-tank connector (inter-tank section)
- 17 instruments and system-monitoring devices
- 18 second rocket stage (S-II)
- 19 J-2 engines
- 20 heat shield (thermal protection shield)
- 21 engine mounts and thrust structure
- 22 acceleration rockets for fuel acquisition
- 23 liquid hydrogen (LH₂) suction line
- 24 liquid oxygen (LOX, LO₂) tank [capacity: 1,315,000 litres]
- 25 standpipe
- 26 liquid hydrogen (LH₂) tank [capacity: 1,020,000 litres]
- 27 fuel level sensor
- 28 work platform (working platform)
- 29 cable duct
- 30 manhole
- 31 S-IC/S-II inter-stage connector (inter-stage section)

- 32 compressed-gas container (gas pressure vessel)
- 33 third rocket stage (S-IVB)
- 34 J-2 engine
- 35 nozzle (thrust nozzle)
- 36 S-III/S-IVB inter-stage connector (inter-stage section)
- 37 four second-stage (S-II) separation retro-rockets
- 38 attitude control rockets
- 39 liquid oxygen (LOX, LO₂) tank [capacity: 77,200 litres]
- 40 fuel line duct
- 41 liquid hydrogen (LH₂) tank [capacity: 253,000 litres]
- 42 measuring probes
- 43 compressed-helium tanks (helium pressure vessels)
- 44 tank vent
- 45 forward frame section
- 46 work platform (working platform)
- 47 cable duct
- 48 acceleration rockets for fuel acquisition
- 49 aft frame section
- 50 compressed-helium tanks (helium pressure vessels)
- 51 liquid hydrogen (LH₂) line
- 52 liquid oxygen (LOX, LO₂) line
- 53 24-panel instrument unit
- 54 LM hangar (lunar module hangar)
- 55 LM (lunar module)
- 56 Apollo SM (service module), containing supplies and equipment
- 57 SM (service module) main engine
- 58 fuel tank
- 59 nitrogen tetroxide tank
- 60 pressurized gas delivery system
- 61 oxygen tanks
- 62 fuel cells
- 63 manoeuvring (Am. maneuvering) rocket assembly
- 64 directional antenna assembly
- 65 space capsule (command section)
- 66 launch phase escape tower

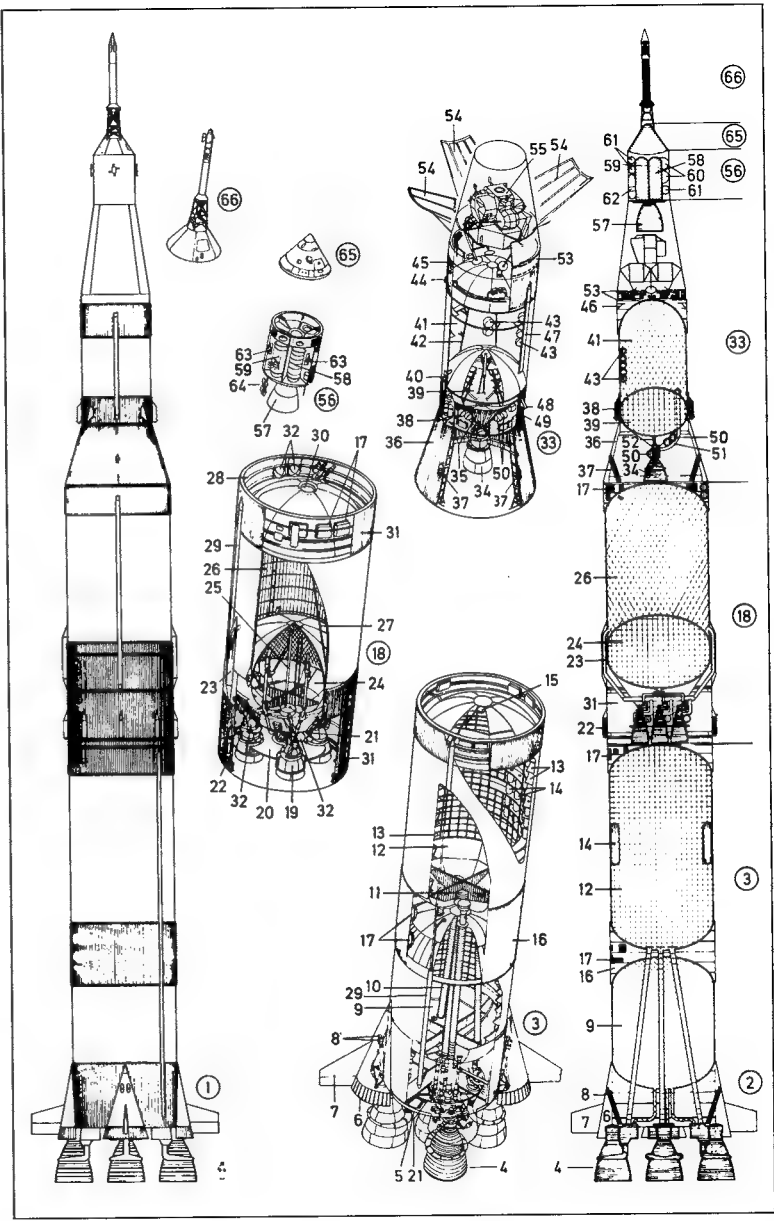

1-45 Space Shuttle-Orbiter

- 1 twin-spar (two-spar, double-spar) vertical fin
- 2 engine compartment structure
- 3 fin post
- 4 fuselage attachment [of payload bay doors]
- 5 upper thrust mount
- 6 lower thrust mount
- 7 keel
- 8 heat shield
- 9 waist longeron
- 10 integrally machined (integrally milled) main rib
- 11 integrally stiffened light alloy skin
- 12 lattice girder
- 13 payload bay insulation
- 14 payload bay door
- 15 low-temperature surface insulation
- 16 flight deck (crew compartment)
- 17 captain's seat (commander's seat)
- 18 pilot's seat (co-pilot's seat)
- 19 forward pressure bulkhead
- 20 carbon fibre reinforced nose cone
- 21 forward fuel tanks
- 22 avionics consoles
- 23 automatic flight control panel
- 24 upward observation windows
- 25 forward observation windows
- 26 entry hatch to payload bay
- 27 air lock
- 28 ladder to lower deck
- 29 payload manipulator arm
- 30 hydraulically steerable nose wheel
- 31 hydraulically operated main landing gear
- 32 removable (reusable) carbon fibre reinforced leading edge [of wing]
- 33 movable elevon sections
- 34 heat-resistant elevon structure
- 35 main liquid hydrogen (LH₂) supply
- 36 main liquid-fuelled rocket engine
- 37 nozzle (thrust nozzle)
- 38 coolant feed line
- 39 engine control system
- 40 heat shield

- 41 high-pressure liquid hydrogen (LH₂) pump
- 42 high-pressure liquid oxygen (LOX, LO₂) pump
- 43 thrust vector control system
- 44 electromechanically controlled orbital manoeuvring (*Am.* manoeuvring) main engine
- 45 nozzle fuel tanks (thrust nozzle fuel tanks)
- 46 **jettisonable liquid hydrogen and liquid oxygen tank** (fuel tank)
- 47 integrally stiffened annular rib (annular frame)
- 48 hemispherical end rib (end frame)
- 49 aft attachment to Orbiter
- 50 liquid hydrogen (LH₂) line
- 51 liquid oxygen (LOX, LO₂) line
- 52 manhole
- 53 surgebaffle system (slosh baffle system)
- 54 pressure line to liquid hydrogen tank
- 55 electrical system bus
- 56 liquid oxygen (LOX, LO₂) line
- 57 pressure line to liquid oxygen tank
- 58 **recoverable solid-fuel rocket** (solid rocket booster)
- 59 auxiliary parachute bay
- 60 compartment housing the recovery parachutes and the forward separation rocket motors
- 61 cable duct
- 62 aft separation rocket motors
- 63 aft skirt
- 64 swivel nozzle (swivelling, *Am.* swiveling, nozzle)
- 65 **Spacelab** (space laboratory, space station)
- 66 multi-purpose laboratory (orbital workshop)
- 67 astronaut
- 68 gimbal-mounted telescope
- 69 measuring instrument platform
- 70 spaceflight module
- 71 crew entry tunnel

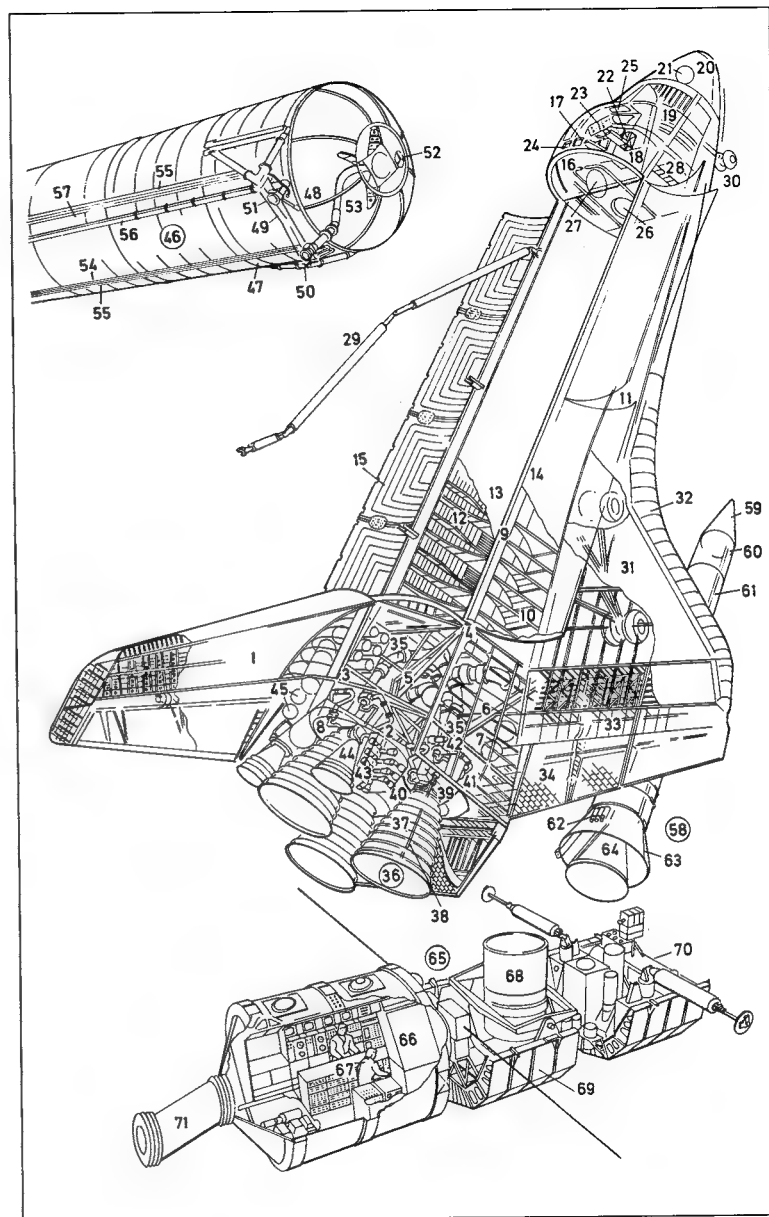

- 1-30 main hall
- 1 parcels counter
- 2 parcels scales
- 3 parcel
- 4 stick-on address label with parcel registration slip
- 5 glue pot
- 6 small parcel
- 7 franking machine (*Am.* postage meter) for parcel registration cards
- 8 telephone box (telephone booth, telephone kiosk, call box)
- 9 coin-box telephone (pay phone, public telephone)
- 10 telephone directory rack
- 11 directory holder
- 12 telephone directory (telephone book)
- 13 post office boxes
- 14 post office box
- 15 stamp counter
- 16 counter clerk (counter officer)
- 17 company messenger
- 18 record of posting book
- 19 counter stamp machine
- 20 stamp book
- 21 sheet of stamps
- 22 security drawer
- 23 change rack
- 24 letter scales
- 25 paying-in (*Am.* deposit), post office savings, and pensions counter
- 26 accounting machine
- 27 franking machine for money orders and paying-in slips (*Am.* deposit slips)
- 28 change machine (*Am.* changemaker)
- 29 receipt stamp
- 30 hatch
- 31-44 letter-sorting installation
- 31 letter feed
- 32 stacked letter containers
- 33 feed conveyor
- 34 intermediate stacker
- 35 coding station
- 36 pre-distributor channel

- 37 process control computer
- 38 distributing machine
- 39 video coding station
- 40 screen
- 41 address display
- 42 address
- 43 post code (postal code, *Am.* zip code)
- 44 keyboard
- 45 handstamp
- 46 roller stamp
- 47 franking machine
- 48 feed mechanism
- 49 delivery mechanism
- 50-55 postal collection and delivery
- 50 postbox (*Am.* mailbox)
- 51 collection bag
- 52 post office van (mail van)
- 53 postman (*Am.* mail carrier, letter carrier, mailman)
- 54 delivery pouch (postman's bag, mailbag)
- 55 letter-rate item
- 56-60 postmarks
- 56 postmark advertisement
- 57 date stamp postmark
- 58 charge postmark
- 59 special postmark
- 60 roller postmark
- 61 stamp (postage stamp)
- 62 perforations

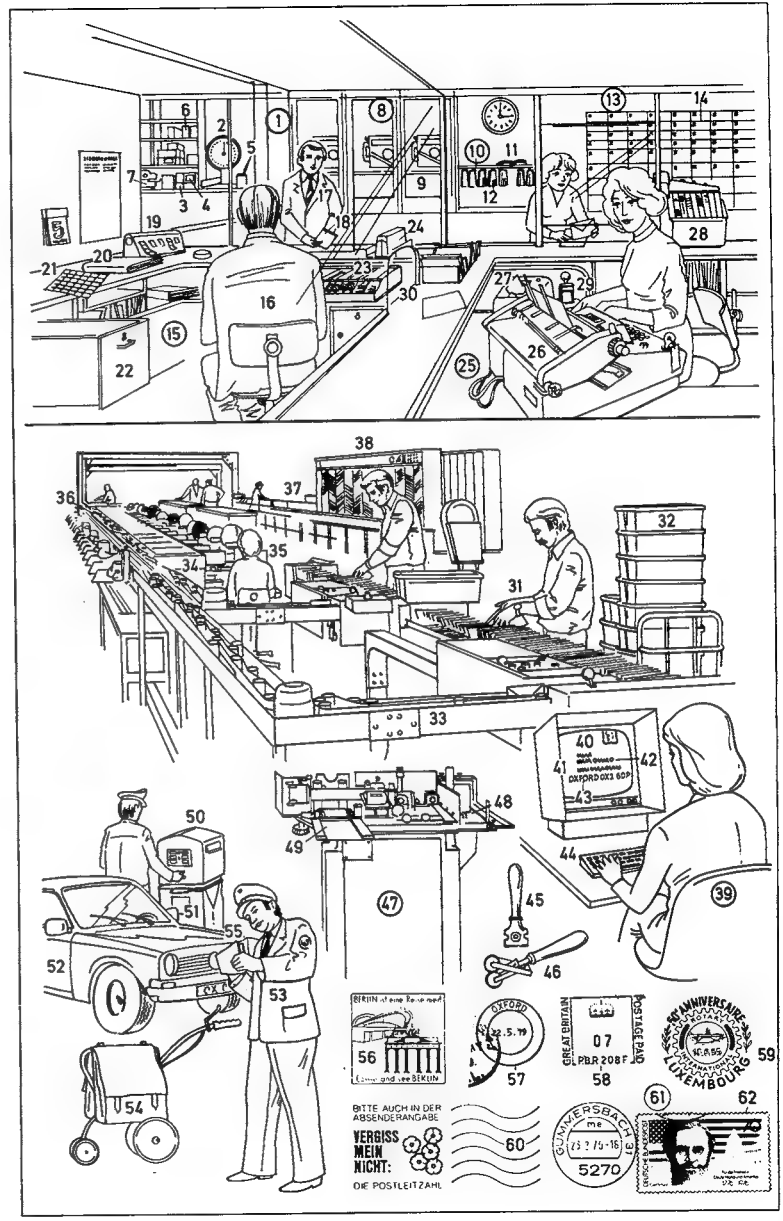

- 1-41 telephone
- 1 dial telephone
- 2 handset (telephone receiver)
- 3 receiver cord (handset cord)
- 4 telephone cable (telephone cord)
- 5 telephone casing (telephone cover)
- 6 emergency numbers
- 7 line number
- 8 dial
- 9 compact telephone (slimline telephone), an added-feature telephone
- 10 earpiece (receiver)
- 11 keypad with number and function keys (feature keys)
- 12 last number redial button
- 13 abbreviated dialling key
- 14 speaker key (loudspeaker key)
- 15 mouthpiece
- 16 line reset button
- 17 speaker (loudspeaker)
- 18 call indicator
- 19 push-button telephone, an added-feature telephone
- 20 display
- 21 lock
- 22 novelty telephone, an added-feature telephone
- 23 (telephone) cradle
- 24 dummy crank
- 25 detachable keypad
- 26 cordless (tele)phone (radiophone, mobile phone)
- 27 aerial
- 28 battery strength light
- 29 out of signal-range indicator
- 30 power switch
- 31 cardphone
- 32 split display showing call charges
- 33 language select button for the display
- 34 follow-on call button
- 35 phonenumber slot
- 36 phonenumber (here: telephone credit card)
- 37 phonenumber symbol
- 38 cardholder's name
- 39 card number
- 40 arrow indicating direction of insertion
- 41 chips
- 42-62 ISDN (Integrated Services Digital Network)
- 42 multifunction telecommunications terminal (ISDN workstation)
- 43 screen (monitor) for viewdata, video telephone, and Teletex
- 44 central processing and memory unit
- 45 fax unit (fax)
- 46 input device (keyboard)
- 47 telephone receiver (link to the telephone network)
- 48 acoustic coupler (modem)
- 49 telecontrol network (TEMEX network)
- 50 public telephone network (switched telephone network)
- 51 telecontrol centres
- 52 TEMEX main control centre
- 53 TEMEX transmission equipment
- 54 telecommunications line (telephone line)
- 55 TEMEX network termination
- 56 slave station
- 57 telecontrol terminal equipment
- 58 telecontrol terminal equipment (detector, sensor, or control equipment)
- 59 glass-break detector
- 60 temperature controller
- 61 emergency call
- 62 meter (electricity meter)
- 63 communications satellite
- 64 solar panel (solar paddle, solar array, solar generator)
- 65 antenna module
- 66 receiving antenna for control commands
- 67 parabolic antennas
- 68 communications module
- 69 propulsion module
- 70 broadcasting satellite (television satellite)
- 71 service module
- 72 fuel tanks
- 73 control jets
- 74 earth station
- 75 parabolic antenna
- 76 main reflector
- 77 feed antenna
- 78 radio beams
- 79 satellite broadcasting, satellite television, and cable television
- 80 broadcasting satellite
- 81 television studio
- 82 television tower
- 83 cablehead station
- 84 terrestrial broadcasting
- 85 satellite broadcasting
- 86 line-of-sight link (microwave link)
- 87 cable network
- 88 cable connections

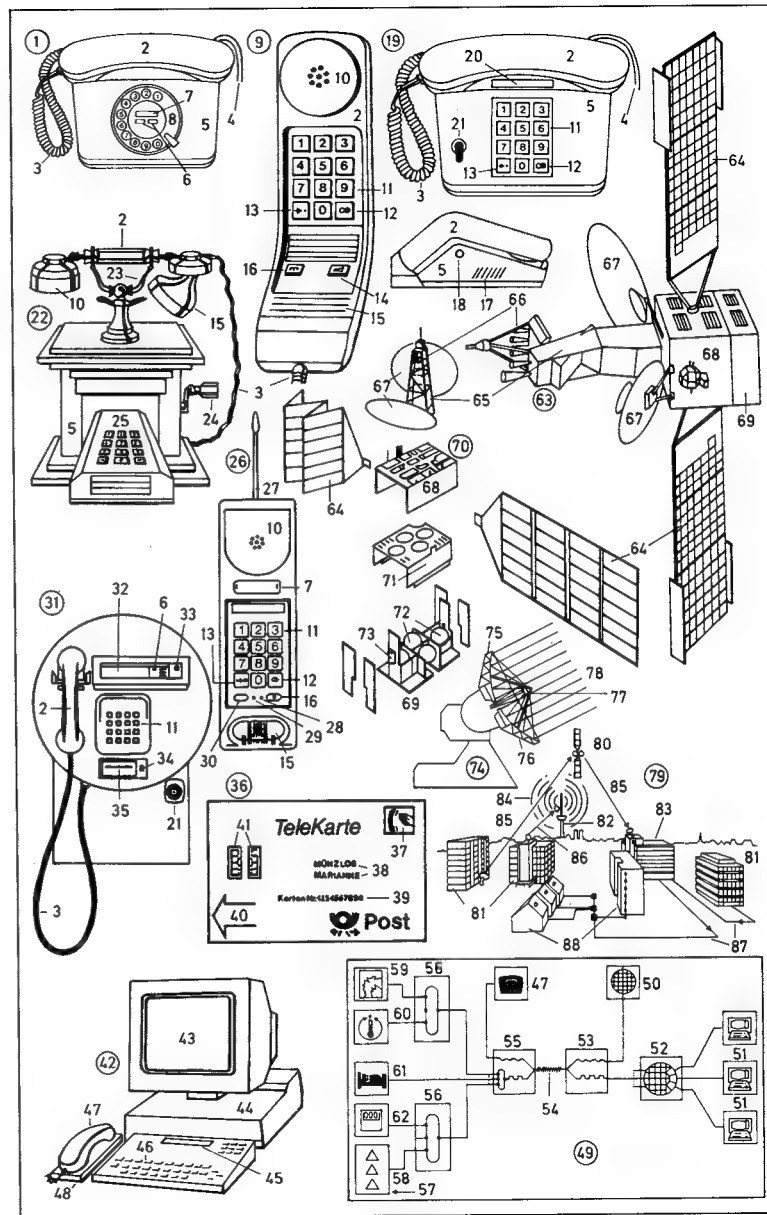

1-6 central recording channel of a radio station

- 1 monitoring and control panel
 - 2 data display terminal (video data terminal, video monitor) for visual display of computer-controlled programmes (*Am.* programmes)
 - 3 amplifier and mains power unit
 - 4 magnetic sound recording and playback deck for 1/4" magnetic tape
 - 5 magnetic tape, a 1/4" tape
 - 6 film spool holder
- 7-15 radio switching centre (*Am.* center) control room**
- 7 monitoring and control panel
 - 8 talkback speaker
 - 9 local-battery telephone
 - 10 talkback microphone
 - 11 data display terminal (video data terminal)
 - 12 teleprinter
 - 13 input keyboard for computer data
 - 14 telephone switchboard panel
 - 15 monitoring speaker (control speaker)
- 16-26 broadcasting centre (*Am.* center) recording room**
- 16 recording room
 - 17 production control room (control room)
 - 18 studio
 - 19 sound engineer (sound control engineer)
 - 20 sound control desk (sound control console)
 - 21 newsreader (newscaster)
 - 22 duty presentation officer
 - 23 telephone for phoned reports
 - 24 record turntable
 - 25 recording room mixing console (mixing desk, mixer)
 - 26 sound technician (sound mixer, sound recordist)
- 27-53 television post-sync studio**
- 27 sound production control room (sound control room)
 - 28 dubbing studio (dubbing theatre, *Am.* theatre)
 - 29 studio table
 - 30 visual signal
 - 31 electronic stopclock

- 32 projection screen
 - 33 monitor
 - 34 studio microphone
 - 35 sound effects box
 - 36 microphone socket panel
 - 37 recording speaker (recording loudspeaker)
 - 38 control room window (studio window)
 - 39 producer's talkback microphone
 - 40 local-battery telephone
 - 41 sound control desk (sound control console)
 - 42 group selector switch
 - 43 visual display
 - 44 limiter display (clipper display)
 - 45 control modules
 - 46 pre-listening buttons
 - 47 slide control
 - 48 universal equalizer (universal corrector)
 - 49 input selector switches
 - 50 pre-listening speaker
 - 51 tone generator
 - 52 talkback speaker
 - 53 talkback microphone
- 54-59 pre-mixing room for transferring and mixing 16 mm, 17.5 mm, 35 mm perforated magnetic film**
- 54 sound control desk (sound control console)
 - 55 compact magnetic tape recording and playback equipment
 - 56 single playback deck
 - 57 central drive unit
 - 58 single recording and playback deck
 - 59 rewind bench
- 60-65 final picture quality checking room**
- 60 preview monitor
 - 61 programme (*Am.* program) monitor
 - 62 stopclock
 - 63 vision mixer (vision-mixing console, vision-mixing desk)
 - 64 talkback system (talkback equipment)
 - 65 camera monitor (picture monitor)

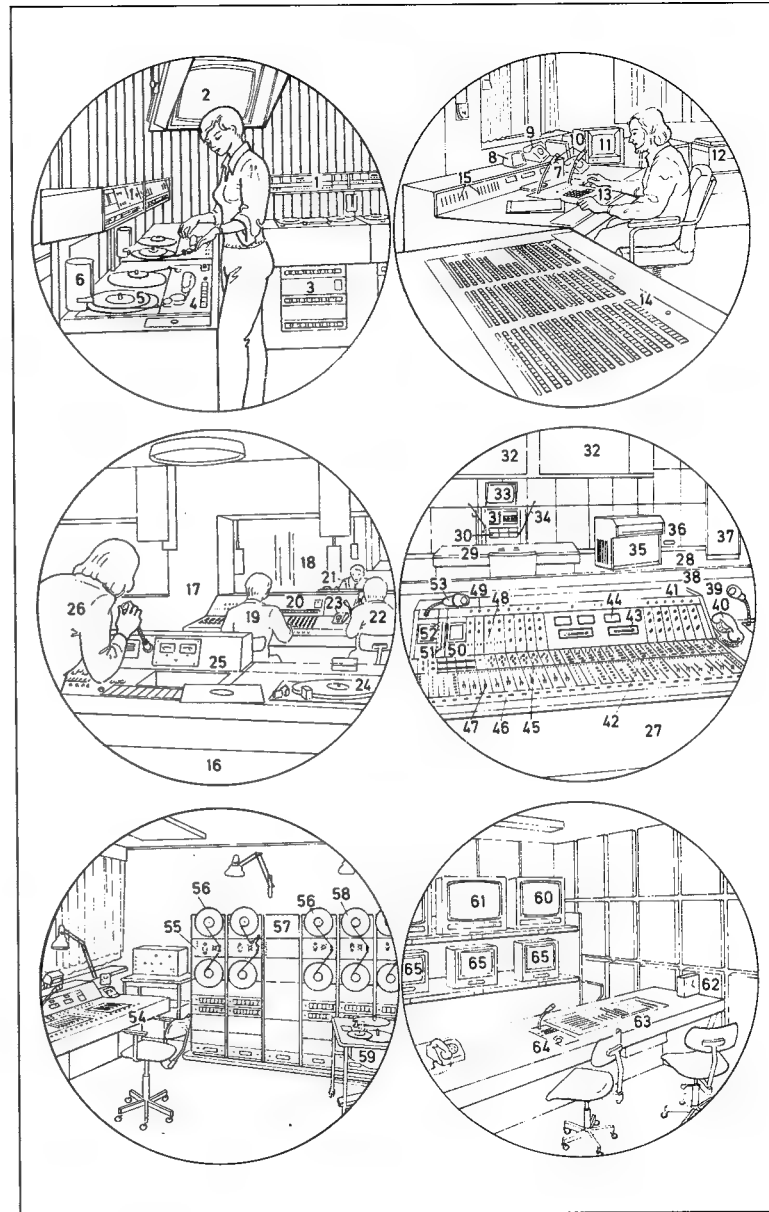

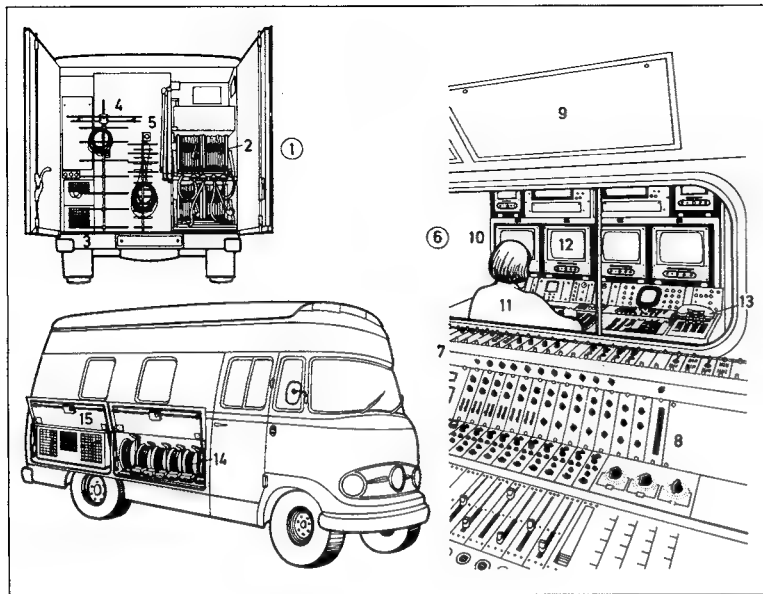

1-15 outside broadcast (OB) vehicle
(television OB van; also: sound OB van, radio OB van)

1-4 rear equipment section of the OB vehicle

2 camera cable

3 cable connection panel

4 television (TV) reception aerial (receiving aerial) for Channel I

5 television (TV) reception aerial (receiving aerial) for Channel II

6 interior equipment (on-board equipment) of the OB vehicle

7 sound production control room (sound control room)

8 sound control desk (sound control console)

9 monitoring loudspeaker

10 vision control room (video control room)

11 video controller (vision controller)

12 camera monitor (picture monitor)

13 on-board telephone (intercommunication telephone)

14 microphone cables

15 air-conditioning plant

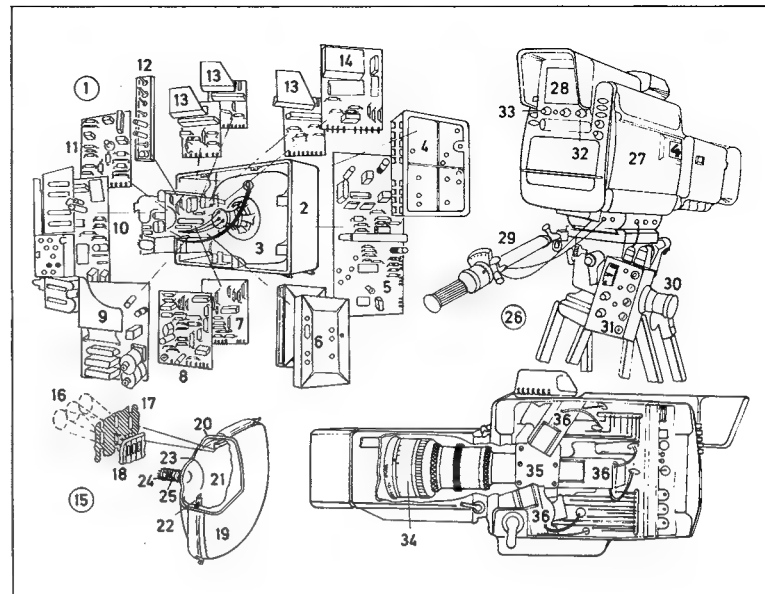

1 colour (Am. color) television (TV) receiver (colour television set) of modular design

2 television cabinet

3 television tube (picture tube)

4 IF (intermediate frequency) amplifier module

5 colour (Am. color) decoder module

6 VHF and UHF tuner

7 horizontal synchronizing module

8 vertical deflection module

9 horizontal linearity control module

10 horizontal deflection module

11 control module

12 convergence module

13 colour (Am. color) output stage module

14 sound module

15 colour (Am. color) picture tube

16 electron beams

17 shadow mask with elongated holes

18 strip of fluorescent (luminescent, phosphorescent) material

19 coating (film) of fluorescent material

20 inner magnetic screen (screening)

21 vacuum

22 temperature-compensated shadow mask mount

23 centring (Am. centering) ring for the deflection system

24 electron gun assembly

25 rapid heat-up cathode

26 television (TV) camera

27 camera head

28 camera monitor

29 control arm (control lever)

30 focusing adjustment

31 control panel

32 contrast control

33 brightness control

34 zoom lens

35 beam-splitting prism (beam splitter)

36 pick-up unit (colour, Am. color, pick-up tube)

- 1-17 **stereo system** (hi-fi system), a midi system
- 1 **hi-fi stack**
- 2 rack lid (rack dust cover, [housing] lid)
- 3 rack (housing) with glass door
- 4 record player (record deck, analogue [*Am.* analog] record player)
- 5 tuner (receiver, radio tuner)
- 6 amplifier (power amplifier)
- 7 double cassette deck (double cassette recorder)
- 8 CD player (compact disc player)
- 9 cassette rack
- 10 record and compact disc rack
- 11 castor
- 12 **speaker** (loudspeaker), a three-way bass reflex speaker
- 13 tweeter, a dome tweeter or piezo tweeter
- 14 mid-range speaker (squawker)
- 15 bass speaker (woofer)
- 16 port
- 17 infrared remote control [unit] (IR remote control [unit])
- 18 **record player** (record deck, analogue [*Am.* analog] record player)
- 19 turntable with direct drive or belt drive
- 20 strobe light (strobe speed control)
- 21 pitch control
- 22 rpm display
- 23 stop button
- 24 auto-return button
- 25 rpm selector (speed selector)
- 26 cue button (down)
- 27 cue button (up)
- 28 stylus (needle)
- 29 pick-up
- 30 size selector (record size selector)
- 31 tone arm (pick-up arm)
- 32 tone arm support (pick-up arm support)
- 33 stylus pressure control
- 34 anti-skate control
- 35 tone arm counterweight (pick-up arm counterweight)
- 36 lid (dust cover)
- 37 **tuner** (receiver, radio tuner)
- 38 power switch
- 39 tuning button (tuning control)

- 40 manual and automatic tuning selection button with muting
- 41 stereo/mono selection button
- 42 strength-of-signal display button
- 43 memory button
- 44 station selection buttons
- 45 frequency selection buttons ([wave] band selection buttons)
- 46 station select display
- 47 fluorescent digital display indicating wave band, frequency, and strength of signal
- 48 LED indicator for stereo and mono mode and automatic tuning
- 49 **amplifier** (power amplifier)
- 50 function select buttons for the turntable, tuner, cassette deck (tape deck), CD player, and monitor (tape monitor)
- 51 filter buttons (high and low filter buttons)
- 52 bass control
- 53 treble control
- 54 balance control
- 55 loudness button
- 56 volume control
- 57 headphone socket
- 58 speaker select buttons
- 59 LED display, a multifunction display
- 60 function display
- 61 **receiver**, a combined tuner-amplifier
- 62 display select button
- 63 liquid crystal display (LCD), a multifunction display
- 64 [graphic] equalizer, a 2 x 7 band [graphic] equalizer
- 65 equalizer slide controls
- 66 LED-display spectrum analyser
- 67 **headphones** (stereo headphones)
- 68 ear pads (ear cushions)
- 69, 70 **microphones**
- 69 directional microphone (stereo directional microphone)
- 70 electret condenser microphone with omnidirectional pick-up characteristic

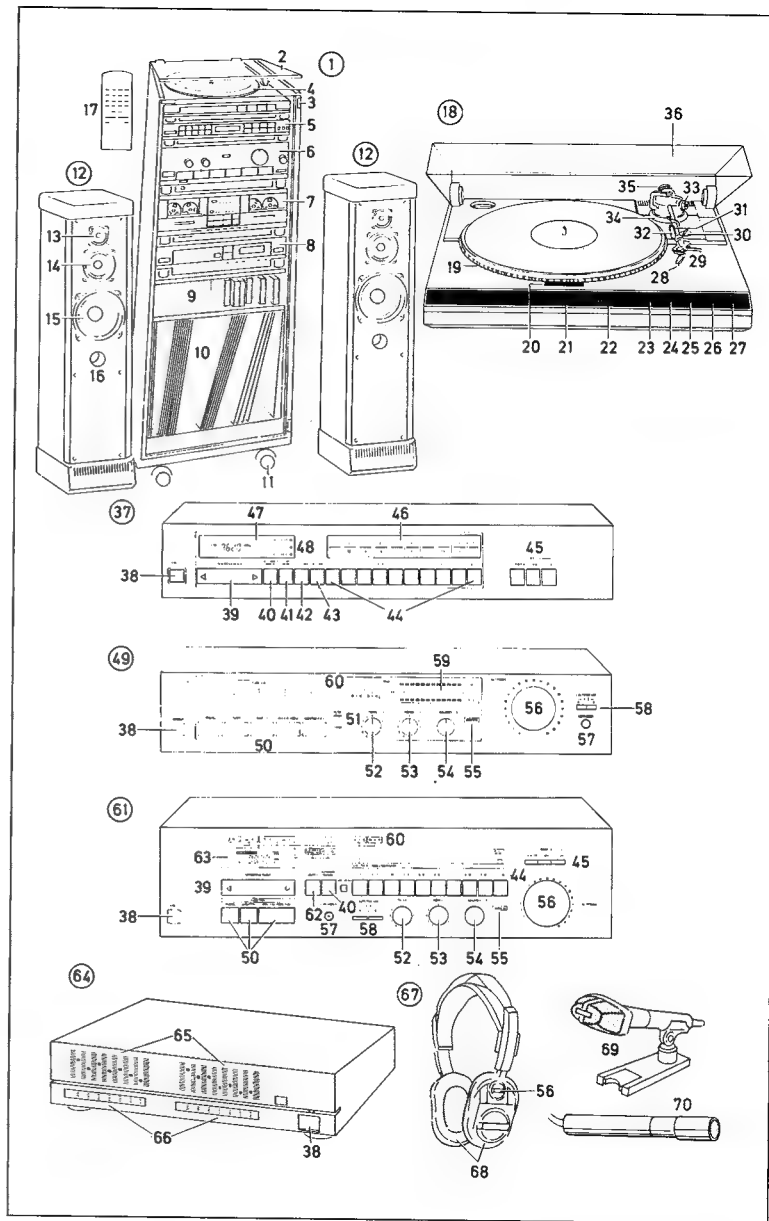

- 1 cassette deck (cassette recorder)
- 2 power switch
- 3 [stop and] eject button
- 4 cassette holder (cassette drive, cassette transport)
- 5 dust cover
- 6 counter (tape counter)
- 7-12 **transport buttons**
- 7 stop button
- 8 rewind button
- 9 play buttons for both directions (bi-directional play buttons)
- 10 fast forward button
- 11 record button
- 12 pause button
- 13 counter reset button
- 14 noise reduction buttons (Dolby select buttons)
- 15 auto-reverse buttons
- 16 recording level control
- 17 microphone sockets
- 18 headphone socket
- 19 level indicator display (VU meter), an LED display
- 20 tape type indicator (tape-bias indicator), an LED display
- 21 **double cassette deck** (double cassette recorder)
- 22 play button
- 23 [stop and] eject button
- 24 high-speed dubbing button
- 25 function select button
- 26 recording indicator light
- 27 on-off light (power indicator light)
- 28 **CD player** (compact disc player, digital compact disc player)
- 29 CD drawer
- 30 open/close button for the CD drawer
- 31 search button and index search button
- 32 skip buttons (skip-track buttons)
- 33 headphone volume control
- 34 function select buttons
- 35 programming, track and disc repeat, and pause indicators
- 36 LED display
- 37 remaining time and track-index indicators
- 38 **portable radio recorder** with integral CD player
- 39 handle
- 40 [radio] receiver (receiver and amplifier)

- 41 CD player
- 42 quartz clock with digital display and timer
- 43 double cassette recorder
- 44 loudspeaker
- 45-49 **audio-cassette** (cassette)
- 45-47 types of tape
- 45 ferric cassette (iron oxide cassette, normal cassette)
- 46 chrome dioxide cassette (chrome cassette)
- 47 metal cassette (metal oxide cassette)
- 48 tape type indication (indicating hole)
- 49 record-protected cassettes
- 50 **world receiver** for receiving ultra-short wave (USW), medium wave (MW), long wave (LW), and short wave (SW)
- 51 aerial (rod aerial), a telescopic aerial
- 52 function buttons
- 53 station select buttons
- 54 manual tuning knob
- 55 liquid crystal display (LCD) showing waveband, frequency, and memory number
- 56 (sliding) volume control
- 57 **cassette player** (Walkman® with radio)
- 58 headphones
- 59 equalizer, a 3-band equalizer
- 60 **portable CD player** (Discman®)
- 61 compact disc (CD)
- 62 lid
- 63 casing with transport, amplifier, display, and function buttons
- 64 **compact hi-fi system** (compact stereo system)
- 65 amplifier section
- 66 **DAT recorder** (digital cassette recorder) (DAT = Digital Audio Tape)
- 67 infrared sensor (IR sensor) for the remote control
- 68 input selection buttons for mono, analogue (*Am.* analog), and digital signals
- 69 index and program selection buttons
- 70 index number display
- 71 auto-scan button
- 72 end-record search button

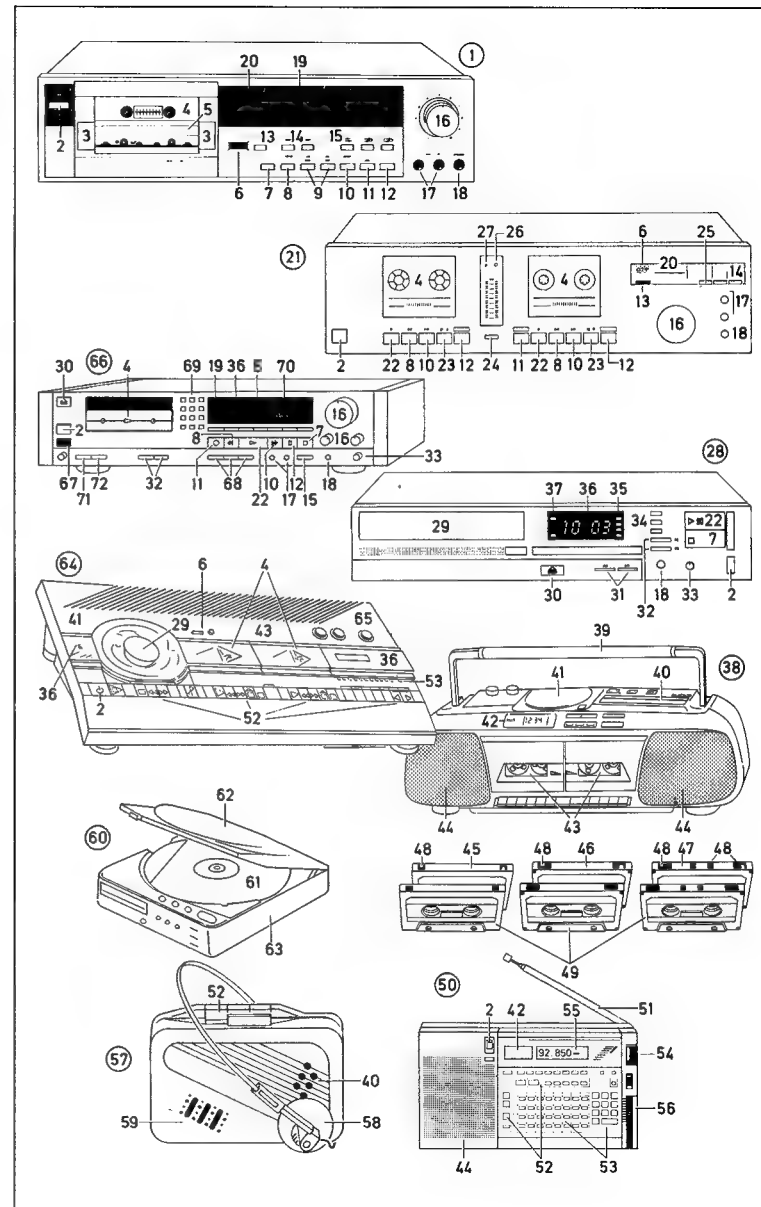

- 1 camcorder (camera recorder),
form: two-component system (separate camera and recorder)
- 2 pocket camcorder, a video-8 camcorder
- 3 lens, a x6 zoom lens (11-66 mm)
- 4 viewfinder (ocular)
- 5 CCD image converter (image sensor) and high-speed shutter, a half-inch chip with shutter functions
- 6 video cassette
- 7 videotape
- 8 head drum
- 9 autofocus motor
- 10 built-in microphone (integral microphone)
- 11 VHS head drum (VHS: Video Home System)
- 12 erase head
- 13 guide pin
- 14 tape guide
- 15 capstan
- 16 audio sync head
- 17 pinch roller
- 18 video head
- 19 grooves in the wall of the head drum to promote air cushion formation
- 20 VHS track format
- 21 direction of tape movement
- 22 direction of recording
- 23 video track, a slant track (only a few tracks shown)
- 24 sound track (audio track)
- 25 sync track
- 26 sync head
- 27 sound head (audio head)
- 28 video head
- 29 video recorder
- 30 infrared remote control
- 31 program scale (program dial), a multidisplay
- 32 cassette compartment
- 33 jog shuttle knob for forward or reverse movement of the [video] picture

- 34 multisc disc player
- 35 infrared remote control
- 36 disc drawer
- 37-41 disc formats
- 37 single compact disc (single CD)
- 38 audio CD
- 39 video CD
- 40 small laser disc (20 cm)
- 41 large laser disc (30 cm)
- 42 laser scanning system
- 43 [disc] spindle
- 44 laser-head tracing spindle
- 45 laser head (laser unit)

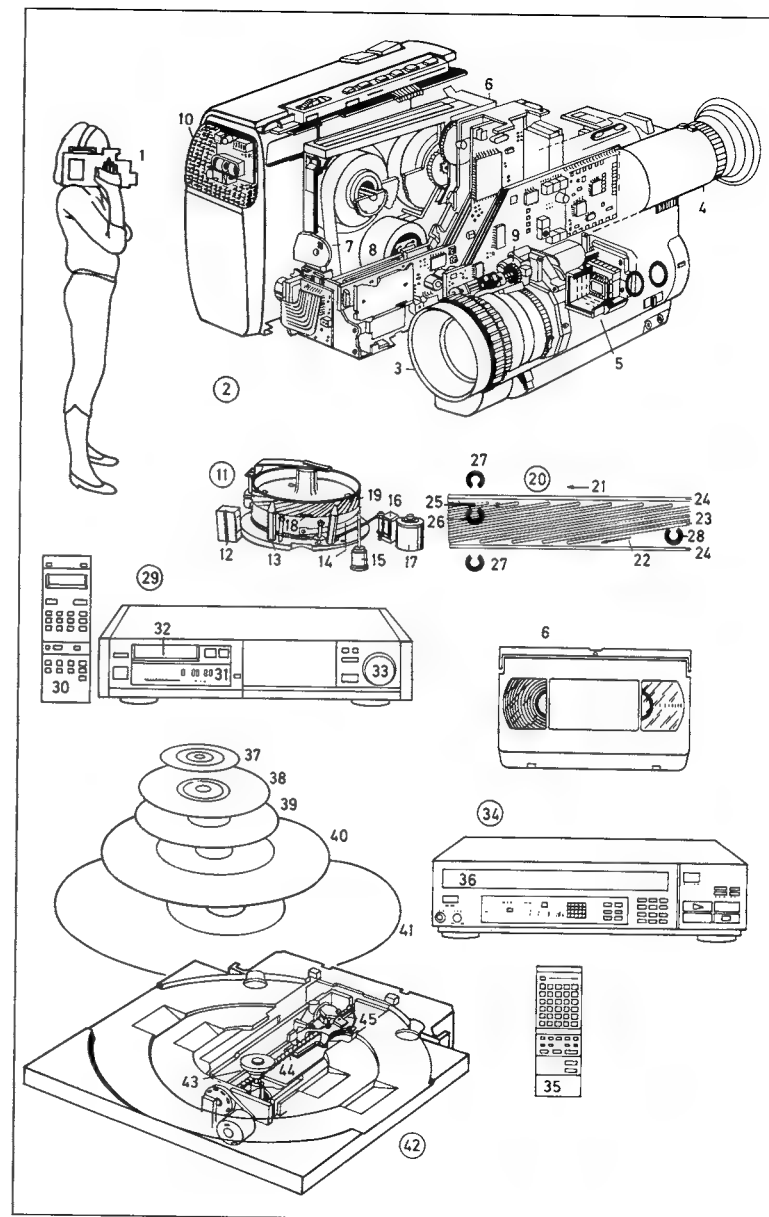

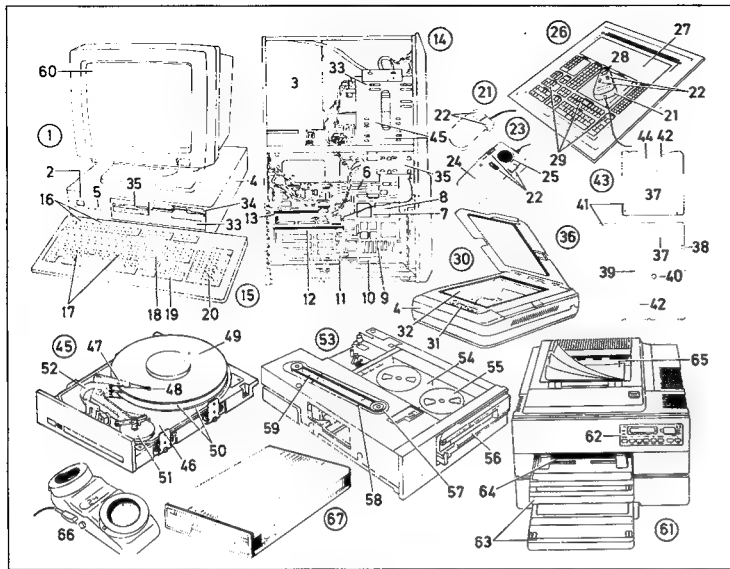

- | | | |
|---|---|---|
| 1 personal computer (PC; <i>sim.</i> : laptop) | 27 graphics area | 49 drive motor for the aluminum (<i>Am.</i> aluminum) platters, a spindle drive motor |
| 2 power switch | 28 cross hairs | 50 magnetic-coated aluminum (<i>Am.</i> aluminum) platters |
| 3 power supply (power pack) | 29 receiving grids | 51 read-write head drive motor, a linear motor or stepping motor (stepper motor) |
| 4 housing | 30 scanner | 52 data, address, and control bus |
| 5 fixed-disk access light | 31 control panel with function keys | 53 magnetic tape unit (magnetic tape drive, streamer) |
| 6 main memory | 32 scanning surface | 54 magnetic tape |
| 7 coprocessor socket | 33-59 mass storage devices (magnetic stores, magnetic memories) | 55 magnetic tape reel |
| 8 central processing unit (CPU), a microprocessor | 33-44 disk drives (drives, floppy disk drives) | 56 magnetic tape cassette (magnetic tape cartridge) |
| 9 cache memory (cache controller) | 33 minifloppy disk drive (5 1/4 inch [floppy] disk drive) | 57 drive post |
| 10 expansion memory slot | 34 latch | 58 drive band |
| 11 graphics card slot | 35 microfloppy disk drive (3 1/2 inch [floppy] disk drive) | 59 drive motor |
| 12 combined fixed and floppy disk controller | 36-44 diskettes (disks, floppy disks, floppies) | 60-65 output devices |
| 13 serial and parallel communication card | 36 minifloppy (minifloppy disk, 5 1/4 inch disk, flexible disk) | 60 screen (monitor, display) a high-resolution colour (<i>Am.</i> color) monitor |
| 14 PC tower interior view | 37 label | 61 printer, a dot-matrix printer (<i>here</i> : laser printer; <i>also</i> : inkjet printer, needle printer) |
| 15-67 peripherals | 38 write-protect notch | 62 control panel with function keys and display head |
| 15-32 built-in devices | 39 hole for engaging the drive hub registration hole | 63 paper tray (paper cassette) |
| 15 keyboard | 40 disk cover (envelope) | 64 paper feed path |
| 16 function keys | 41 access slot for the read-write head | 65 paper output tray |
| 17 letter keys and number keys (numeric keys) | 42 microfloppy (3 1/2 inch [floppy] disk) | 66, 67 devices for long-distance data transmission |
| 18 enter key (return key) | 43 sliding shutter | 66 acoustic coupler |
| 19 cursor keys | 44 fixed-disk drive (fixed disk, hard disk) | 67 modem |
| 20 number [key]pad (numeric [key]pad) | 45 roller ball | |
| 21 mouse | 46 base plate | |
| 22 mouse buttons | 47 access arm (actuator) | |
| 23 trackball (trackball) | 48 read-write head | |

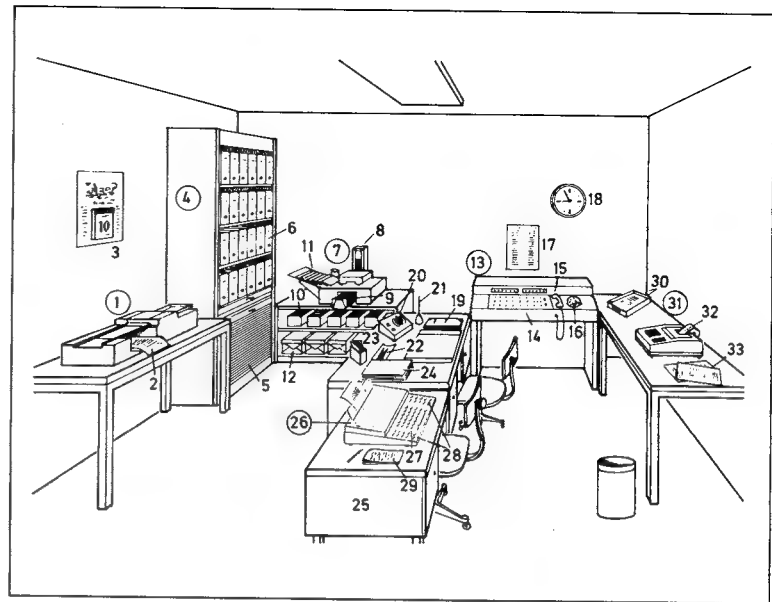

1-33 receptionists office (secretary's office)

- | | |
|--|---|
| 1 fax machine | 19 folder containing documents, correspondence, etc. for signing (to be signed) |
| 2 transmitted or received copy | 20 intercom (office intercom) |
| 3 wall calendar | 21 pen |
| 4 filing cabinet | 22 pen and pencil tray |
| 5 tambour door (roll-up door) | 23 card index |
| 6 file (document file) | 24 stack (set) of forms |
| 7 transfer-type addressing machine | 25 typing desk |
| 8 vertical stencil magazine | 26 electronic memory typewriter |
| 9 stencil ejection | 27 keyboard |
| 10 stencil storage drawer | 28 function keys |
| 11 paper feed | 29 shorthand pad (<i>Am.</i> steno pad) |
| 12 stock of notepaper | 30 letter tray |
| 13 switchboard (internal telephone exchange) | 31 office calculator |
| 14 push-button keyboard for internal connections | 32 printer |
| 15 handset | 33 business letter |
| 16 dial | |
| 17 internal telephone list | |
| 18 master clock (main clock) | |

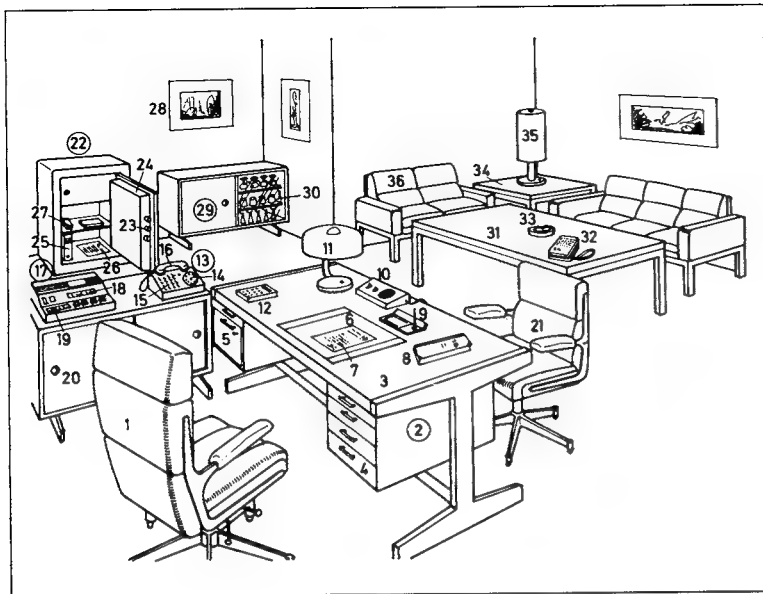
**1-36 executive's office**

- 1 swivel chair
- 2 desk
- 3 desk top
- 4 desk drawer
- 5 cupboard (storage area) with door
- 6 desk mat (blotter)
- 7 business letter
- 8 appointments diary
- 9 desk set
- 10 intercom (office intercom)
- 11 desk lamp
- 12 pocket calculator (electronic calculator)
- 13 telephone, an executive-secretary system
- 14 dial; *also*: push-button keyboard
- 15 call buttons
- 16 receiver (telephone receiver)
- 17 dictating machine
- 18 position indicator
- 19 control buttons (operating keys)
- 20 cabinet
- 21 visitor's chair
- 22 safe
- 23 bolts
- 24 armour-plated (*Am.* armor-plated) lock area
- 25 confidential documents
- 26 patent
- 27 petty cash
- 28 picture
- 29 bar (drinks cabinet)
- 30 bar set
- 31-36 conference grouping
- 31 conference table
- 32 pocket-sized dictating machine, a micro-cassette recorder
- 33 ashtray
- 34 corner table
- 35 table lamp
- 36 two-seater sofa [part of the conference grouping]

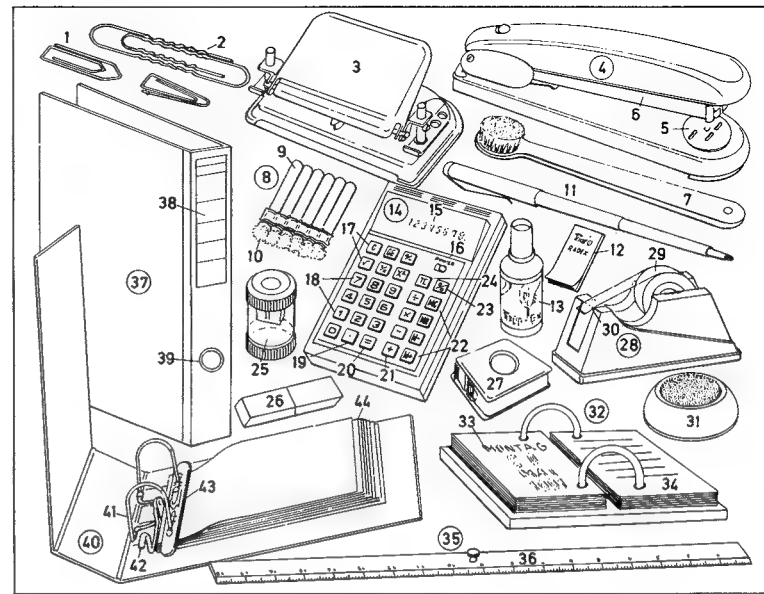
**1-44 office equipment** (office supplies, office materials)

- 1, 2 paper clips
- 3 punch
- 4 stapler (stapling machine)
- 5 anvil
- 6 spring-loaded magazine
- 7 type-cleaning brush
- 8 type cleaner (type-cleaning kit)
- 9 fluid container (fluid reservoir)
- 10 cleaning brush
- 11 felt tip pen
- 12 correcting paper [for typing errors]
- 13 correcting fluid [for typing errors]
- 14 electronic pocket calculator
- 15 eight-digit fluorescent display
- 16 on/off switch
- 17 function keys
- 18 number keys
- 19 decimal key
- 20 'equals' key
- 21 instruction keys (command keys)
- 22 memory keys
- 23 percent key (percentage key)
- 24 π -key (pi-key) for mensuration of circles
- 25 pencil sharpener
- 26 typewriter rubber
- 27 adhesive tape dispenser
- 28 adhesive tape holder (roller-type adhesive tape dispenser)
- 29 roll of adhesive tape
- 30 tear-off edge
- 31 moistener
- 32 desk diary
- 33 date sheet (calendar sheet)
- 34 memo sheet
- 35 ruler
- 36 centimetre and millimetre (*Am.* centimeter and millimeter) graduations
- 37 file (document file)
- 38 spine label (spine tag)
- 39 finger hole
- 40 arch board file
- 41 arch unit
- 42 release lever (locking lever, release/lock lever)
- 43 compressor
- 44 bank statement (statement of account)

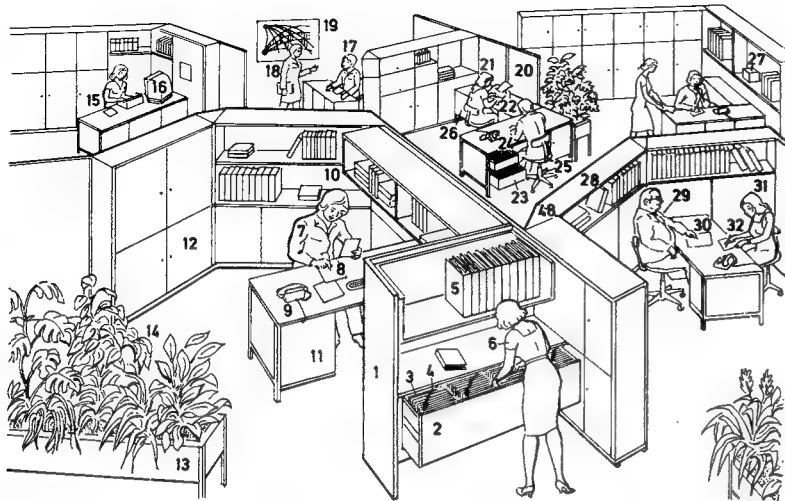
**1-48 open plan office**

- | | |
|--|--|
| 1 partition wall (partition screen) | 21 typist |
| 2 filing drawer with suspension file system | 22 typewriter |
| 3 suspension file | 23 filing drawer |
| 4 file tab | 24 customer card index |
| 5 file (document file) | 25 office chair, a swivel chair |
| 6 filing clerk | 26 typing desk |
| 7 clerical assistant | 27 card index box |
| 8 note for the files | 28 multi-purpose shelving |
| 9 telephone | 29 proprietor |
| 10 filing shelves | 30 business letter |
| 11 clerical assistant's desk | 31 proprietor's secretary |
| 12 office cupboard | 32 shorthand pad (<i>Am. steno pad</i>) |
| 13 plant stand (planter) | 33 audio typist |
| 14 indoor plants (houseplants) | 34 dictating machine |
| 15 programmer | 35 earphone |
| 16 data display terminal (visual display unit) | 36 statistics chart |
| 17 customer service representative | 37 pedestal containing a cupboard or drawers |
| 18 customer | 38 sliding-door cupboard |
| 19 computer-generated design | 39 office furniture arranged in an angular configuration |
| 20 sound-absorbing partition | 40 wall-mounted shelf |
| | 41 letter tray |



- | |
|--|
| 42 wall calendar |
| 43 data centre (<i>Am. center</i>) |
| 44 calling up information on the data display terminal (visual display unit) |
| 45 waste paper basket |
| 46 sales statistics |
| 47 EDP print-out, a continuous fan-fold sheet |
| 48 connecting element |

- 1 electric typewriter, a golf ball typewriter
- 2-6 keyboard
- 2 space bar
- 3 shift key
- 4 line space and carrier return key
- 5 shift lock
- 6 margin release key
- 7 tabulator key
- 8 tabulator clear key
- 9 on/off switch
- 10 striking force control (impression control)
- 11 ribbon selector
- 12 margin scale
- 13 left margin stop
- 14 right margin stop
- 15 golf ball (spherical typing element) bearing the types
- 16 ribbon cassette
- 17 paper bail with rollers
- 18 platen
- 19 typing opening (typing window)
- 20 paper release lever
- 21 carrier return lever
- 22 platen knob
- 23 line space adjuster
- 24 variable platen action lever
- 25 push-in platen variable
- 26 erasing table
- 27 transparent cover
- 28 exchange golf ball (exchange typing element)
- 29 type
- 30 golf ball cap (cap of typing element)
- 31 teeth
- 32 photocopier (copier, photocopying machine)
- 33 copyboard cover with single-copy (single-sheet) delivery tray
- 34 universal paper cassette
- 35 adjustable paper cassettes
- 36 front door
- 37 dual vertical transport unit
- 38 sorter
- 39 copy delivery bins
- 40-43 control panel displays and control keys

- 40 enlargement, reduction, and program selection keys
- 41 sort mode and two-sided copy keys
- 42 display with colour, exposure, format, and copy number selection keys
- 43 start key (copy start key)
- 44 letter-folding machine
- 45 paper feed
- 46 folding mechanism
- 47 receiving tray
- 48 small offset press
- 49 paper feed
- 50 lever for inking the plate cylinder
- 51, 52 inking unit (inker unit)
- 51 distributing roller (distributor)
- 52 ink roller (inking roller, fountain roller)
- 53 pressure adjustment
- 54 sheet delivery (receiving table)
- 55 printing speed adjustment
- 56 jogger for aligning the piles of sheets
- 57 pile of paper (pile of sheets)
- 58 folding machine
- 59 gathering machine (collating machine, assembling machine) for short runs
- 60 gathering station (collating station, assembling station)
- 61 adhesive binder (perfect binder) for hot adhesives
- 62 magnetic tape dictating machine
- 63 headphones (headset, earphones)
- 64 on/off switch
- 65 microphone cradle
- 66 foot control socket
- 67 telephone adapter socket
- 68 headphone socket (earphone socket, headset socket)
- 69 microphone socket
- 70 built-in loudspeaker
- 71 indicator lamp (indicator light)
- 72 cassette compartment
- 73 forward wind, rewind, and stop buttons
- 74 time scale with indexing marks
- 75 time scale stop

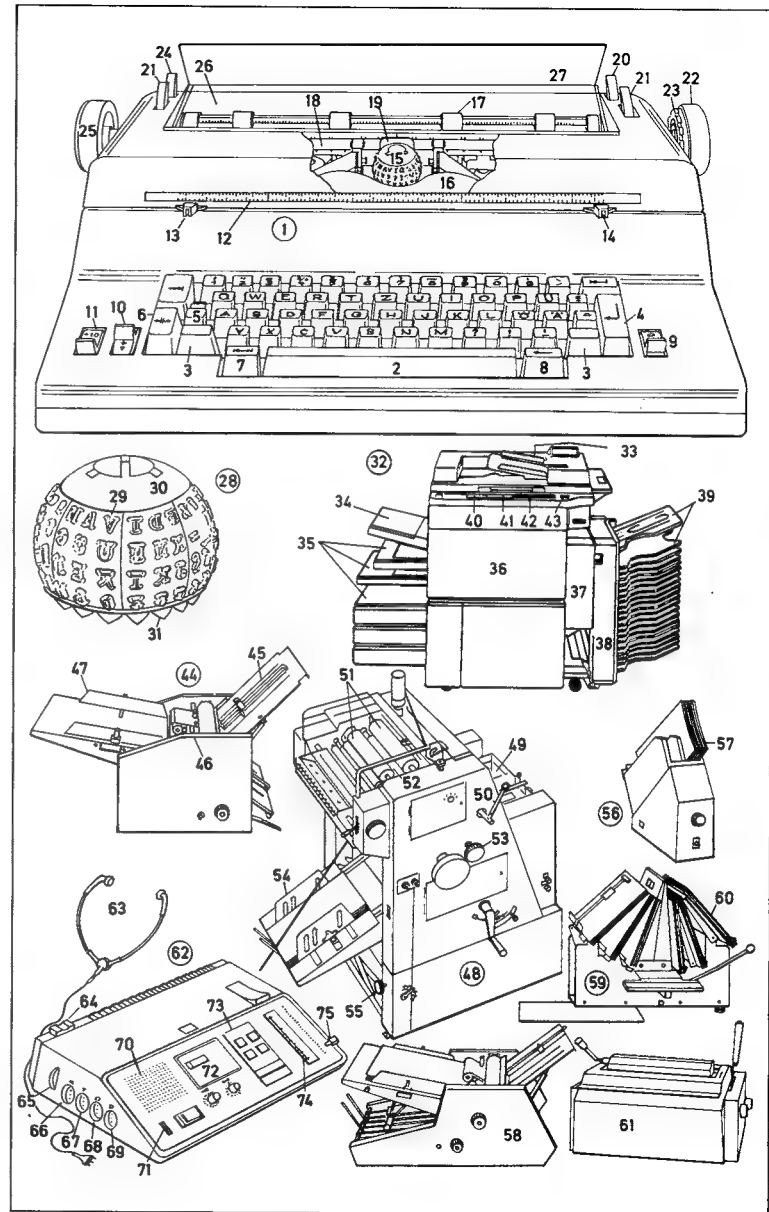

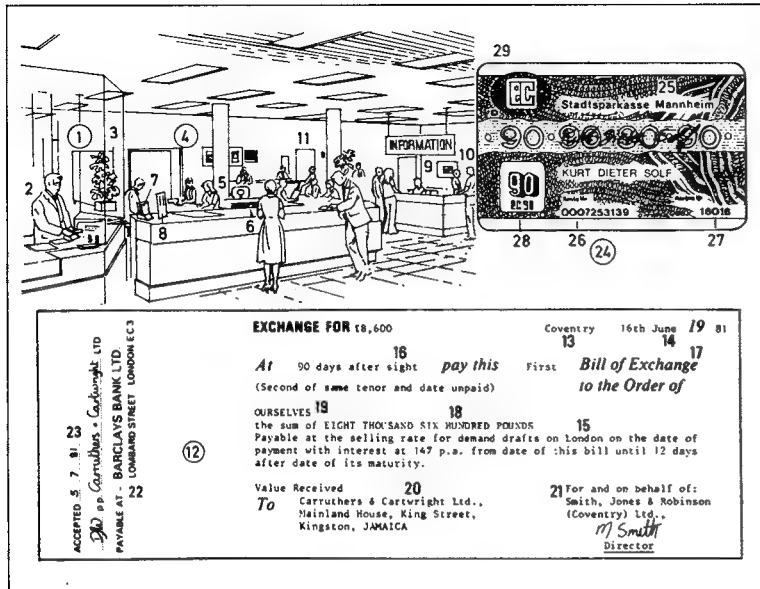
**1-11 main hall**

- 1 cashier's desk (cashier's counter)
- 2 teller (cashier)
- 3 bullet-proof glass
- 4 service counters (for service and advice on savings accounts, private and company accounts, personal loans)
- 5 bank clerk
- 6 customer
- 7 brochures
- 8 stock list (price list, list of quotations)
- 9 information counter
- 10 foreign exchange counter
- 11 entrance to strong room
- 12 bill of exchange (bill); *here*: a draft, an acceptance (bank acceptance)
- 13 place of issue
- 14 date of issue
- 15 place of payment
- 16 date of maturity (due date)
- 17 bill clause (draft clause)

18 value

- 19 payee (remittee)
- 20 drawee (payer)
- 21 drawer
- 22 domiciliation (paying agent)
- 23 acceptance
- 24 Eurocheque card
- 25 issuing bank (drawee bank)
- 26 account number
- 27 card number
- 28 hologram, a white light hologram (rainbow hologram)
- 29 (*on the back*:) magnetic strip

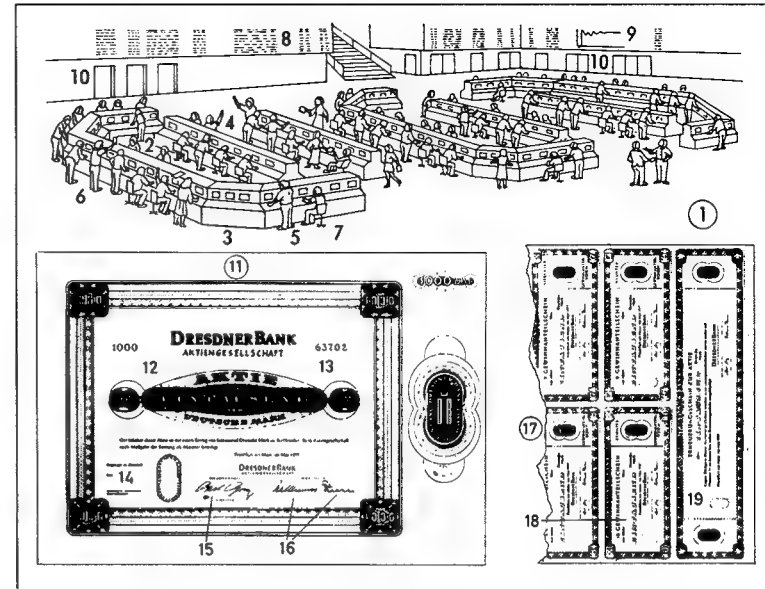
**1-10 stock exchange**

- 1 exchange hall (exchange floor)
- 2 market for securities
- 3 broker's post
- 4 sworn stockbroker (exchange broker, stockbroker, *Am.* specialist), an inside broker
- 5 kerbstone broker (kerbstoner, curbstone broker, curbstoner, outside broker), a commercial broker dealing in unlisted securities
- 6 member of the stock exchange (stockjobber, *Am.* floor trader, room trader)
- 7 stock exchange agent (boardman), a bank employee
- 8 quotation board
- 9 index curve
- 10 telephone box (telephone booth, telephone kiosk, call box)

11-19 securities; kinds: share (*Am.*

- stock), fixed-income security, annuity, bond, debenture bond, municipal bond (corporation stock), industrial bond, convertible bond
- 11 share certificate (*Am.* stock certificate); *here*: bearer share (share warrant)
- 12 par (par value, nominal par, face par) of the share
- 13 serial number
- 14 page number of entry in bank's share register (bank's stock ledger)
- 15 signature of the chairman of the board of governors
- 16 signature of the chairman of the board of directors
- 17 sheet of coupons (coupon sheet, dividend coupon sheet)
- 18 dividend warrant (dividend coupon)
- 19 talon

- 1-29 coins (coin, coinage, metal money, specie, *Am.* hard money); *kinds*: gold, silver, nickel, copper, or aluminium, *Am.* aluminum, coins
- 1 Athens: tetradrachm (tetradrachmon, tetradrachma)
- 2 the owl [emblem of the city of Athens]
- 3 aureus of Constantine the Great
- 4 bracteate of Emperor Frederick I Barbarossa
- 5 Louis XIV louis-d'or
- 6 Prussia: 1 reichstaler (speciestaler) of Frederick the Great
- 7 Federal Republic of Germany: 5 Deutschmarks (DM); 1 DM = 100 pfennigs
- 8 obverse
- 9 reverse (subordinate side)
- 10 mint mark (mintage, exergue)
- 11 legend (inscription on the edge of a coin)
- 12 device (type), a provincial coat of arms
- 13 Austria: 25 schillings; 1 sch = 100 groschen
- 14 provincial coats of arms
- 15 Switzerland: 5 francs; 1 franc = 100 centimes
- 16 France: 1 franc = 100 centimes
- 17 Belgium: 100 francs
- 18 Luxembourg (Luxemburg): 1 franc
- 19 Netherlands: 2 1/2 guilders; 1 guilder (florin, gulden) = 100 cents
- 20 Italy: 200 lire (*sg.* lira)
- 21 Vatican City: 100 lire (*sg.* lira)
- 22 Spain: 1 peseta = 100 céntimos
- 23 Portugal: 1 escudo = 100 centavos
- 24 Denmark: 1 krone = 100 öre
- 25 Sweden: 1 krona = 100 öre
- 26 Norway: 1 krone = 100 öre
- 27 Czechoslovakia: 1 koruna = 100 heller
- 28 Yugoslavia: 1 dinar = 100 paras
- 29 United Kingdom of Great Britain and Northern Ireland: 1 pound sterling (£1) = 100 new pence (100 p) (*sg.* new penny, new p)
- 30-39 banknotes (*Am.* bills) (paper money, notes, treasury notes)
- 30 Federal Republic of Germany: 100 DM
- 31 bank of issue (bank of circulation)
- 32 watermark [a portrait]
- 33 denomination
- 34 USA: 1 dollar (\$) = 100 cents
- 35 facsimile signatures
- 36 impressed stamp
- 37 serial number
- 38 Greece: 1,000 drachmas (drachmae); 1 drachma = 100 lepta (*sg.* lepton)
- 39 portrait
- 40-44 striking of coins (coinage, mintage)
- 40, 41 coining dies (minting dies)
- 40 upper die
- 41 lower die
- 42 collar
- 43 coin disc (flan, planchet, blank)
- 44 coining press (minting press)



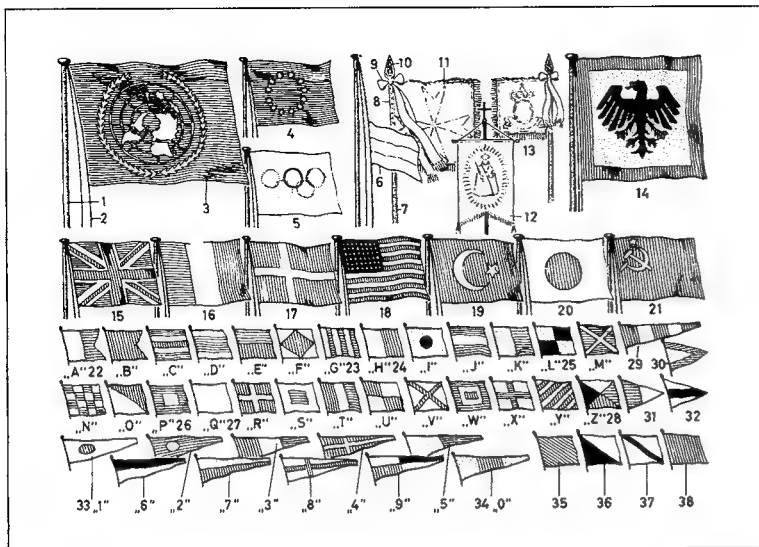

- 1-3** flag of the United Nations
1 flagpole (flagstaff) with truck
2 halyard (halliard, haulyard)
3 bunting
4 flag of the Council of Europe
5 Olympic flag
6 flag at half-mast (*Am.* at half-staff) [as a token of mourning]
7-11 flag
7 flagpole (flagstaff)
8 ornamental stud
9 streamer
10 pointed tip of the flagpole
11 bunting
12 banner (gonfalon)
13 cavalry standard (flag of the cavalry)
14 standard of the German Federal President [ensign of head of state]
15-21 national flags
15 the Union Jack (Great Britain)
16 the Tricolour (*Am.* Tricolor) (France)
17 the Danebrog (Dannebrog) (Denmark)
18 the Stars and Stripes (Star-Spangled Banner) (USA)
19 the Crescent (Turkey)
20 the Rising Sun (Japan)
21 the Hammer and Sickle (USSR)

- 22-34** signal flags, a hoist
22-28 letter flags
22 letter A, a burgee (swallow-tailed flag)
23 G, pilot flag
24 H ('pilot on board')
25 L ('you should stop, I have something important to communicate')
26 P, the Blue Peter ('about to set sail')
27 W ('I require medical assistance')
28 Z, an oblong pennant (oblong pendant)
29 code pennant (code pendant), used in the International Signals Code
30-32 substitute flags (repeaters), triangular flags (pennants, pendants)
33, 34 numeral pennants (numeral pendants)
33 number 1
34 number 0
35-38 customs flags
35 customs boat pennant (customs boat pendant)
36 'ship cleared through customs'
37 customs signal flag
38 powder flag ['inflammable (flammable) cargo']

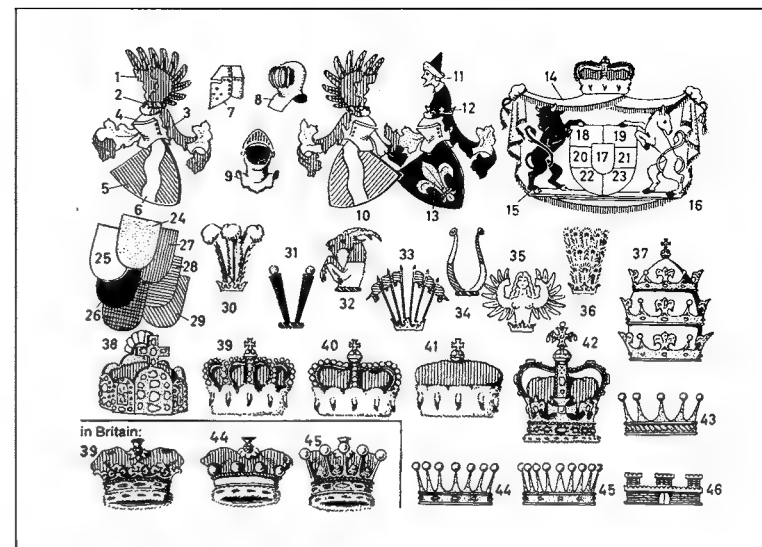

- 1-36** heraldry (blazonry)
1, 11, 30-36 crests
1-6 coat-of-arms (achievement of arms, hatching, achievement)
1 crest
2 wreath of the colours (*Am.* colors)
3 mantle (mantling)
4, 7-9 helmets (helms)
4 tilting helmet (jousting helmet)
5 shield
6 bend sinister wavy
7 pot-helmet (pot-helm, heaume)
8 barred helmet (grilled helmet)
9 helmet affronty with visor open
10-13 marital achievement (marshaled, *Am.* marshaled, coat-of-arms)
10 arms of the baron (of the husband)
11-13 arms of the family of the femme (of the wife)
11 demi-man; *also:* demi-woman
12 crest coronet
13 fleur-de-lis
14 heraldic tent (mantling)
15, 16 supporters (heraldic beasts)
15 bull
16 unicorn
17-23 blazon
17 inescutcheon (heart-shield)
18-23 quarterings one to six
18, 20, 22 dexter (right)
18, 19 chief

- 19, 21, 23** sinister (left)
22, 23 base
24-29 tinctures
24, 25 metals
24 or (gold) [yellow]
25 argent (silver) [white]
26 sable
27 gules
28 azure
29 vert
30 ostrich feathers (treble plume)
31 truncheon
32 demi-goat
33 tournament pennons
34 buffalo horns
35 harpy
36 plume of peacock's feathers
37, 38, 42-46 crowns and coronets [continental type]
37 tiara (papal tiara)
38 Imperial Crown [German, until 1806]
39 ducal coronet (duke's coronet)
40 prince's coronet
41 elector's coronet
42 English Royal Crown
43-45 coronets of rank
43 baronet's coronet
44 baron's coronet (baronial coronet)
45 count's coronet
46 mauerkrone (mural crown) of a city crest

1-96 army armament (army weaponry)
1-28 hand weapons
 1 P1 pistol
 2 barrel
 3 front sight (foresight)
 4 hammer
 5 trigger
 6 pistol grip
 7 magazine holder
 8 MP2 submachine gun
 9 shoulder rest (butt)
 10 casing (mechanism casing)
 11 barrel clamp (barrel-clamping nut)
 12 cocking lever (cocking handle)
 13 palm rest
 14 safety catch
 15 magazine
 16 G3-A3 self-loading rifle
 17 flash hider (flash eliminator)
 18 trigger mechanism
 19 notch (sighting notch, rear sight)
 20 front sight block (foresight block) with front sight (foresight)
 21 rifle butt (butt)
 22 44 2A1 light anti-tank rocket launcher
 23 rocket (projectile)
 24 telescopic sight (telescope sight)
 25 cheek rest
 26 MG3 machine gun (Spandau)
 27 recoil booster
 28 belt-changing flap
29-61 artillery weapons mounted on self-propelled gun carriages
 29 SFM 110 A2 self-propelled howitzer
30-32 gun carriage
 30 drive wheel
 31 track
 32 road wheel
 33 hull
 34 spade
 35 spade piston
 36 hydraulic system
 37 elevating piston
 38 breech ring
 39 barrel
 40 muzzle
 41 buffer (buffer recuperator)
 42 M 109 A3 G self-propelled howitzer
 43 armoured (Am. armored) turret
 44 fighting compartment
 45 barrel clamp
 46 fume extractor
 47 barrel recuperator
 48 light anti-aircraft (AA) machine gun
 49 SF Lance missile launch system (missile launcher)
 50 skirt

51 tracked vehicle
 52 missile (guided missile)
 53 elevating gear
 54 launching ramp
 55 110 SF 2 rocket launcher
 56 fire control system
 57 launching tubes
 58 tube bins
 59 turntable
 60 jack
 61 driver's cab
62-87 armoured (Am. armored) vehicles
 62 Leopard 2 tank
 63 smooth-barrelled gun
 64 driver's hatch
 65 commander's periscope
 66 smoke canister (smoke dispenser)
 67 Luchs armoured (Am. armored) reconnaissance vehicle, an amphibious vehicle
 68 cannon
 69 hatch
 70 antenna
 71 propeller (for propulsion in water)
 72 Jagdpanzer Jaguar 1 ATGW vehicle (HOT)
 73 guidance system (upper part) with guidance unit
 74 HOT guided-missile launcher
 75 firing mechanism (upper part)
 76 commander's cupola
 77 Marder armoured (Am. armored) personnel carrier
 78 searchlight
 79 MILAN anti-tank guided-missile system
80 Fuchs armoured (Am. armored) personnel and load carrier, an amphibious vehicle
 81 rear door
 82 Gepard anti-aircraft tank
 83 surveillance radar
 84 tracking radar for fire control
 85 twin 35 mm cannon
 86 M113 A1 G armoured (Am. armored) personnel carrier
 87 machine gun on a traversing mount
88-96 helicopters
 88 CH-53 G transport helicopter
 89 single rotor
 90 turbine
 91 stabilizing tail rotor
 92 fuselage
 93 cockpit
 94 BO-105P anti-tank helicopter
 95 skid
 96 HOT anti-tank guided-missile launcher

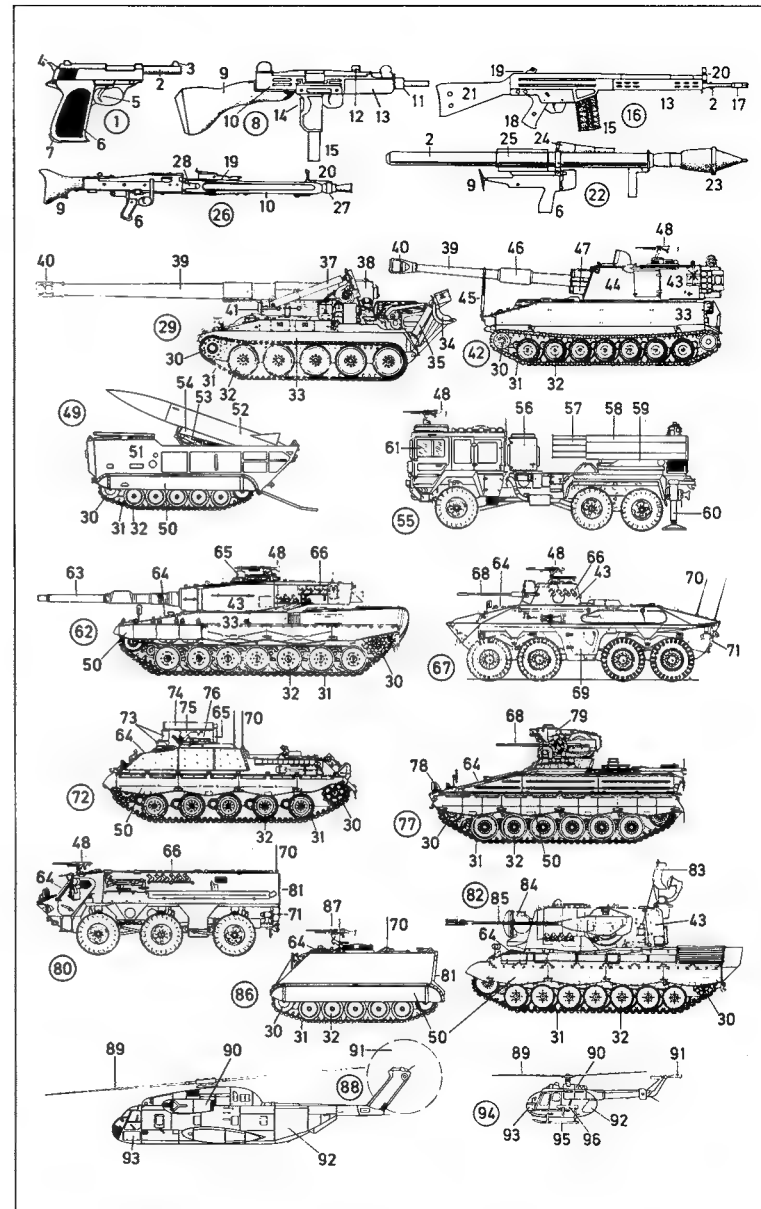

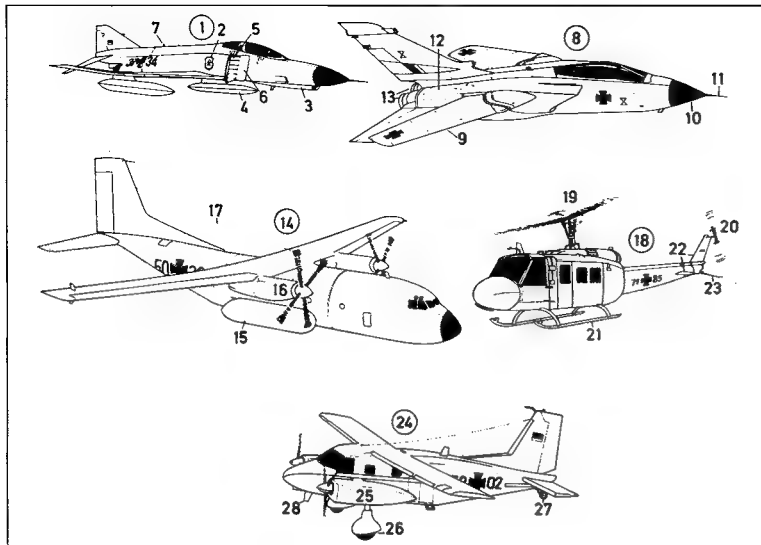

1 McDonnell-Douglas F-4F Phantom II interceptor and fighter-bomber

- 2 squadron marking
- 3 aircraft cannon
- 4 wing tank (underwing tank)
- 5 air intake
- 6 boundary layer control flap
- 7 in-flight refuelling (Am. refueling) probe (flight refuelling probe, air refuelling probe)

8 Panavia 2000 Tornado multirole combat aircraft (MRCA)

- 9 swing wing
- 10 radar nose (radome, radar dome)
- 11 pitot-static tube (pitot tube)
- 12 brake flap (air brake)
- 13 afterburner exhaust nozzles of the engines

14 C160 Transall medium-range transport aircraft

- 15 undercarriage housing (landing gear housing)

16 propeller-turbine engine (turbo-prop engine)

17 antenna

18 Bell UH-1D Iroquois light transport and rescue helicopter

- 19 main rotor
- 20 tail rotor
- 21 landing skids
- 22 stabilizing fins (stabilizing surfaces, stabilizers)

23 tail skid

24 Dornier DO 28 D-2 Skyservant transport and communications aircraft

- 25 engine pod
- 26 main undercarriage unit (main landing gear unit)
- 27 tail wheel
- 28 sword antenna

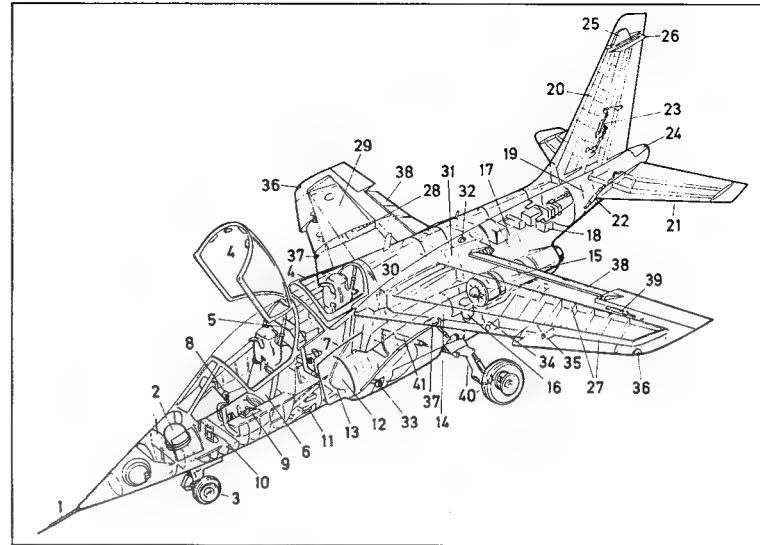

1-41 Dornier-Dassault-Breguet Alpha Jet Franco-German jet trainer

- 1 pitot-static tube (pitot tube)
- 2 oxygen tank
- 3 forward-retracting nose wheel
- 4 cockpit canopy (cockpit hood)
- 5 canopy jack
- 6 pilot's seat (student pilot's seat), an ejector seat (ejection seat)
- 7 observer's seat (instructor's seat), an ejector seat (ejection seat)
- 8 control column (control stick)
- 9 thrust lever
- 10 rudder pedals with brakes
- 11 front avionics bay
- 12 air intake to the engine
- 13 boundary layer control flap
- 14 air intake duct
- 15 turbine engine
- 16 reservoir for the hydraulic system
- 17 battery housing
- 18 rear avionics bay
- 19 baggage compartment
- 20 triple-spar tail construction
- 21 horizontal tail
- 22 servo-actuating mechanism for the elevator

23 servo-actuating mechanism for the rudder

- 24 brake chute housing (drag chute housing)
- 25 VHF (very high frequency) antenna (UHF antenna)
- 26 VOR (very high frequency omnidirectional range) antenna
- 27 twin-spar wing construction
- 28 former with integral spars
- 29 integral wing tanks
- 30 centre-section (Am. center-section) fuel tank
- 31 fuselage tanks
- 32 gravity fuelling (Am. fueling) point
- 33 pressure fuelling (Am. fueling) point
- 34 inner wing suspension
- 35 outer wing suspension
- 36 navigation lights (position lights)
- 37 landing lights
- 38 landing flap
- 39 aileron actuator
- 40 forward-retracting main undercarriage unit (main landing gear unit)
- 41 undercarriage hydraulic cylinder (landing gear hydraulic cylinder)

- 1 Hamburg class **guided-missile destroyer**
- 2 hull of flush-deck vessel
- 3 bow (stem)
- 4 flagstaff (jackstaff)
- 5 anchor, a stockless anchor (patent anchor)
- 6 anchor capstan (windlass)
- 7 breakwater (*Am. manger board*)
- 8 chine strake
- 9 main deck
- 10-28 superstructures
- 10 superstructure deck
- 11 life rafts
- 12 cutter (ship's boat)
- 13 davit (boat-launching crane)
- 14 bridge (bridge superstructure)
- 15 side navigation light (side running light)
- 16 antenna
- 17 radio direction finder (RDF) frame
- 18 lattice mast
- 19 forward funnel
- 20 aft funnel
- 21 cowl
- 22 aft superstructure (poop)
- 23 capstan
- 24 companion ladder (companionway, companion hatch)
- 25 ensign staff
- 26 stern, a transom stern
- 27 waterline
- 28 searchlight
- 29-37 armament
- 29 100 mm gun turret
- 30 four-barrel anti-submarine rocket launcher (missile launcher)
- 31 40 mm twin anti-aircraft (AA) gun
- 32 MM 38 anti-aircraft (AA) rocket launcher (missile launcher) in launching container
- 33 anti-submarine torpedo tube
- 34 depth-charge thrower
- 35 weapon system radar
- 36 radar antenna (radar scanner)
- 37 optical rangefinder
- 38 Lütjens class **guided-missile destroyer**
- 39 bower anchor
- 40 propeller guard
- 41 tripod lattice mast
- 42 pole mast
- 43 ventilator openings (ventilator grill)
- 44 exhaust pipe
- 45 ship's boat
- 46 antenna
- 47 radar-controlled 127 mm all-purpose gun in turret
- 48 127 mm all-purpose gun
- 49 launcher for Tartar missiles
- 50 anti-submarine rocket (ASROC) launcher (missile launcher)
- 51 fire control radar antennas
- 52 radome (radar dome)
- 53 Bremen class **frigate**
- 54 radar-controlled 76 mm rapid-fire gun
- 55 Sea Sparrow surface-to-air missiles
- 56 radar and fire control system
- 57 Harpoon surface-to-surface missiles
- 58 funnel
- 59 cowl
- 60 air/surface search radar
- 61 cutter
- 62 close-range surface-to-air missiles
- 63 helicopter deck
- 64 type 206 **submarine**
- 65 flooded foredeck
- 66 pressure hull
- 67 turret
- 68 retractable instruments
- 69 type 148 **missile-firing fast attack craft**
- 70 76 mm all-purpose gun with turret
- 71 missile-launching housing
- 72 deckhouse
- 73 40 mm anti-aircraft (AA) gun
- 74 propeller guard moulding (*Am. molding*)
- 75 type 143 **missile-firing fast attack craft**
- 76 breakwater (*Am. manger board*)
- 77 radome (radar dome)
- 78 torpedo tube
- 79 exhaust escape flue
- 80 type 331 **mine hunter**
- 81 reinforced rubbing strake
- 82 inflatable boat (inflatable dinghy)
- 83 davit
- 84 type 341 **minesweeper**
- 85 cable winch
- 86 towing winch (towing machine, towing engine)
- 87 mine-sweeping gear (paravanes)
- 88 crane (davit)
- 89 Barbe class **landing craft**
- 90 bow ramp
- 91 stern ramp
- 92 Rhein class **tender**
- 93 Lüneburg class **support ship**
- 94 Sachsenwald class **mine transport**
- 95 Helgoland class **salvage tug**
- 96 replenishment tanker 'Eifel'

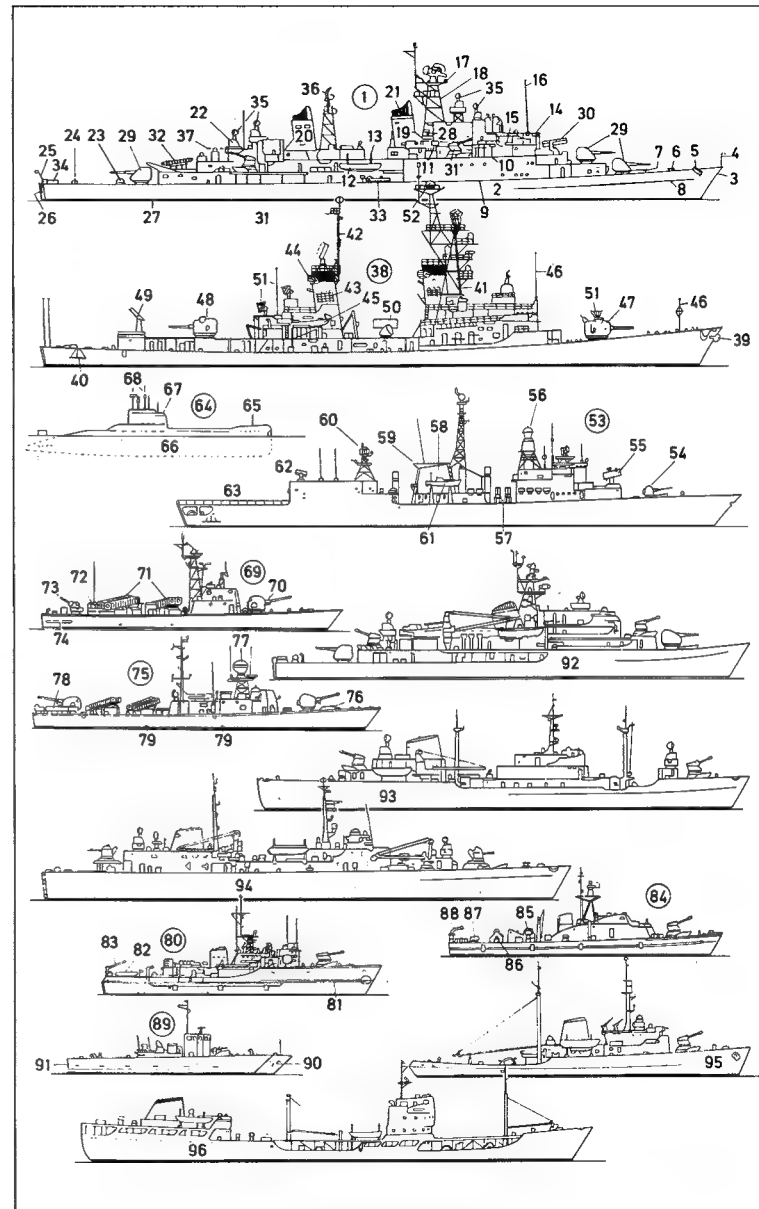

- | | |
|---|---|
| 1 nuclear-powered aircraft carrier <i>Nimitz</i>
<i>ICVN68</i> (USA) | 48 radar antenna (radar scanner) |
| 2-11 body plan | 49 radome (radar dome) |
| 2 flight deck | 50 surface-to-air rocket launcher (missile launcher) |
| 3 island (bridge) | 51 underwater rocket launcher (missile launcher) |
| 4 aircraft lift (<i>Am.</i> aircraft elevator) | 52 127 mm gun with turret |
| 5 eight-barrel anti-aircraft (AA) rocket launcher (missile launcher) | 53 helicopter landing platform |
| 6 pole mast (antenna mast) | 54 nuclear-powered fleet submarine |
| 7 antenna | 55-74 middle section [diagram] |
| 8 radar antenna (radar scanner) | 55 pressure hull |
| 9 fully enclosed bow | 56 auxiliary engine room |
| 10 deck crane | 57 rotary turbine pump |
| 11 transom stern | 58 steam turbine generator |
| 12-20 deck plan | 59 propeller shaft |
| 12 angle deck (flight deck) | 60 thrust block |
| 13 aircraft lift (<i>Am.</i> aircraft elevator) | 61 reduction gear |
| 14 twin launching catapult | 62 high and low pressure turbine |
| 15 hinged (movable) baffle board | 63 high-pressure steam pipe for the secondary water circuit (auxiliary water circuit) |
| 16 arrester wire | 64 condenser |
| 17 emergency crash barrier | 65 primary water circuit |
| 18 safety net | 66 heat exchanger |
| 19 caisson (cofferdam) | 67 nuclear reactor casing (atomic pile casing) |
| 20 eight-barrel anti-aircraft (AA) rocket launcher (missile launcher) | 68 reactor core |
| 21 <i>Kara class</i> rocket cruiser (missile cruiser) (USSR) | 69 control rods |
| 22 hull of flush-deck vessel | 70 lead screen |
| 23 sheer | 71 turret |
| 24 twelve-barrel underwater salvo rocket launcher (missile launcher) | 72 snorkel (schnorkel) |
| 25 twin anti-aircraft (AA) rocket launcher (missile launcher) | 73 air inlet |
| 26 launching housing for 4 short-range rockets (missiles) | 74 retractable instruments |
| 27 baffle board | 75 patrol submarine with conventional (diesel-electric) drive |
| 28 bridge | 76 pressure hull |
| 29 radar antenna (radar scanner) | 77 flooded foredeck |
| 30 twin 76 mm anti-aircraft (AA) gun turret | 78 outer flap (outer doors) [for torpedoes] |
| 31 turret | 79 torpedo tube |
| 32 funnel | 80 bow bilge |
| 33 twin anti-aircraft (AA) rocket launcher (missile launcher) | 81 anchor |
| 34 automatic anti-aircraft (AA) gun | 82 anchor winch |
| 35 ship's boat | 83 battery |
| 36 underwater 5-torpedo housing | 84 living quarters with folding bunks |
| 37 underwater 6-salvo rocket launcher (missile launcher) | 85 commanding officer's cabin |
| 38 helicopter hangar | 86 main hatchway |
| 39 helicopter landing platform | 87 flagstaff |
| 40 variable depth sonar (VDS) | 88-91 retractable instruments |
| 41 <i>California class</i> rocket cruiser (missile cruiser) (USA) | 88 attack periscope |
| 42 hull | 89 antenna |
| 43 forward turret | 90 snorkel (schnorkel) |
| 44 aft turret | 91 radar antenna (radar scanner) |
| 45 forward superstructure | 92 exhaust outlet |
| 46 landing craft | 93 heat space (hot-pipe space) |
| 47 antenna | 94 diesel generators |
| | 95 aft diving plane and vertical rudder |
| | 96 forward vertical rudder |

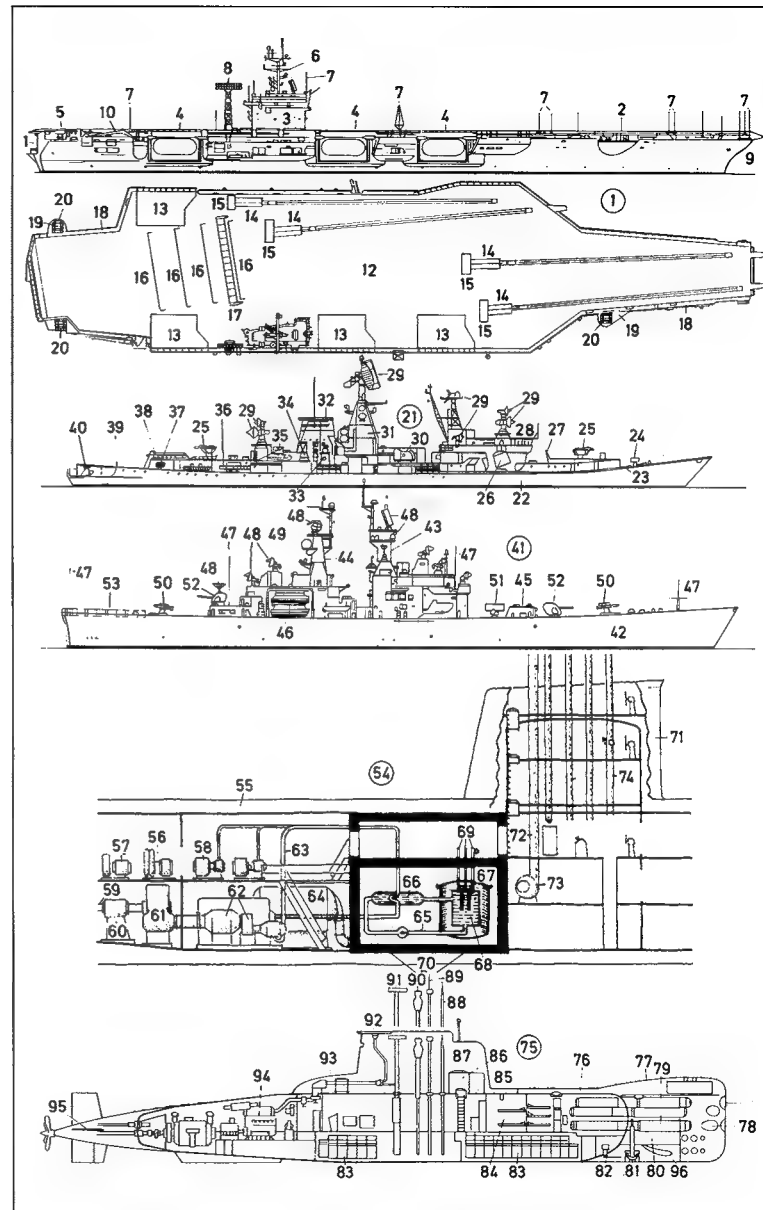

1-85 primary school

1-45 classroom

- 1 arrangement of desks in a horse-shoe
- 2 double desk
- 3 pupils (children) in a group (sitting in a group)
- 4 exercise book
- 5 pencil
- 6 wax crayon
- 7 school bag
- 8 handle
- 9 school satchel (satchel)
- 10 front pocket
- 11 strap (shoulder strap)
- 12 pen and pencil case
- 13 zip (*Am.* zipper)
- 14 fountain pen (pen)
- 15 loose-leaf file (ring file)
- 16 reader
- 17 spelling book
- 18 exercise book (notebook)
- 19 felt tip pen
- 20 pupil raising her hand
- 21 teacher
- 22 teacher's desk
- 23 register
- 24 pen and pencil tray
- 25 desk mat (blotter)
- 26 window painting with finger paints (finger painting)
- 27 pupils' (children's) paintings (watercolours, *Am.* watercolors)
- 28 cross
- 29 three-part blackboard
- 30 bracket for holding charts
- 31 chalk ledge
- 32 chalk
- 33 blackboard drawing
- 34 diagram
- 35 reversible side blackboard
- 36 projection screen
- 37 triangle
- 38 protractor
- 39 divisions
- 40 blackboard compass
- 41 sponge tray
- 42 blackboard sponge (sponge)
- 43 classroom cupboard
- 44 map (wall map)

- 45 brick wall
- 46-85 craft room
- 46 workbench
- 47 vice (*Am.* vise)
- 48 vice (*Am.* vise) bar
- 49 scissors
- 50-52 working with glue (sticking paper, cardboard, etc.)
- 50 surface to be glued
- 51 tube of glue
- 52 tube cap
- 53 fretsaw
- 54 fretsaw blade (saw blade)
- 55 wood rasp (rasp)
- 56 piece of wood held in the vice (*Am.* vise)
- 57 glue pot
- 58 stool
- 59 brush
- 60 pan (dustpan)
- 61 broken china
- 62 enamelling (*Am.* enameling)
- 63 electric enamelling (*Am.* enameling) stove
- 64 unworked copper
- 65 enamel powder
- 66 hair sieve
- 67-80 pupils' (children's) work
- 67 clay models (models)
- 68 window decoration of coloured (*Am.* colored) glass
- 69 glass mosaic picture (glass mosaic)
- 70 mobile
- 71 paper kite (kite)
- 72 wooden construction
- 73 polyhedron
- 74 hand puppets
- 75 clay masks
- 76 cast candles (wax candles)
- 77 wood carving
- 78 clay jug
- 79 geometrical shapes made of clay
- 80 wooden toys
- 81 materials
- 82 stock of wood
- 83 inks for wood cuts
- 84 paintbrushes
- 85 bag of plaster of Paris



- 1-45 grammar school; also: upper band of a comprehensive school (Am. alternative school)
- 1-13 chemistry**
- 1 chemistry lab (chemistry laboratory) with tiered rows of seats
- 2 chemistry teacher
- 3 demonstration bench (teacher's bench)
- 4 water pipe
- 5 tiled working surface
- 6 sink
- 7 television monitor, a screen for educational programmes (Am. programs)
- 8 overhead projector
- 9 projector top for skins
- 10 projection lens with right-angle mirror
- 11 pupils' (Am. students') bench with experimental apparatus
- 12 electrical point (socket)
- 13 projection table
- 14-34 biology preparation room (biology prep room)**
- 14 skeleton
- 15 casts of skulls
- 16 calvarium of Pithecanthropus erectus
- 17 skull of Steinheim man
- 18 calvarium of Peking man (of Sinanthropus)
- 19 skull of Neanderthal man, a skull of primitive man
- 20 Australopithecine skull (skull of Australopithecus)
- 21 skull of present-day man
- 22 dissecting bench
- 23 chemical bottles
- 24 gas tap
- 25 petri dish
- 26 measuring cylinder
- 27 work folder containing teaching material
- 28 textbook
- 29 bacteriological cultures
- 30 incubator

- 31 test tube rack
- 32 washing bottle
- 33 water tank
- 34 sink
- 35 language laboratory
- 36 blackboard
- 37 console
- 38 headphones (headset)
- 39 microphone
- 40 earcup
- 41 padded headband (padded headpiece)
- 42 programme (Am. program) recorder, a cassette recorder
- 43 pupil's (Am. student's) volume control
- 44 master volume control
- 45 control buttons (operating keys)

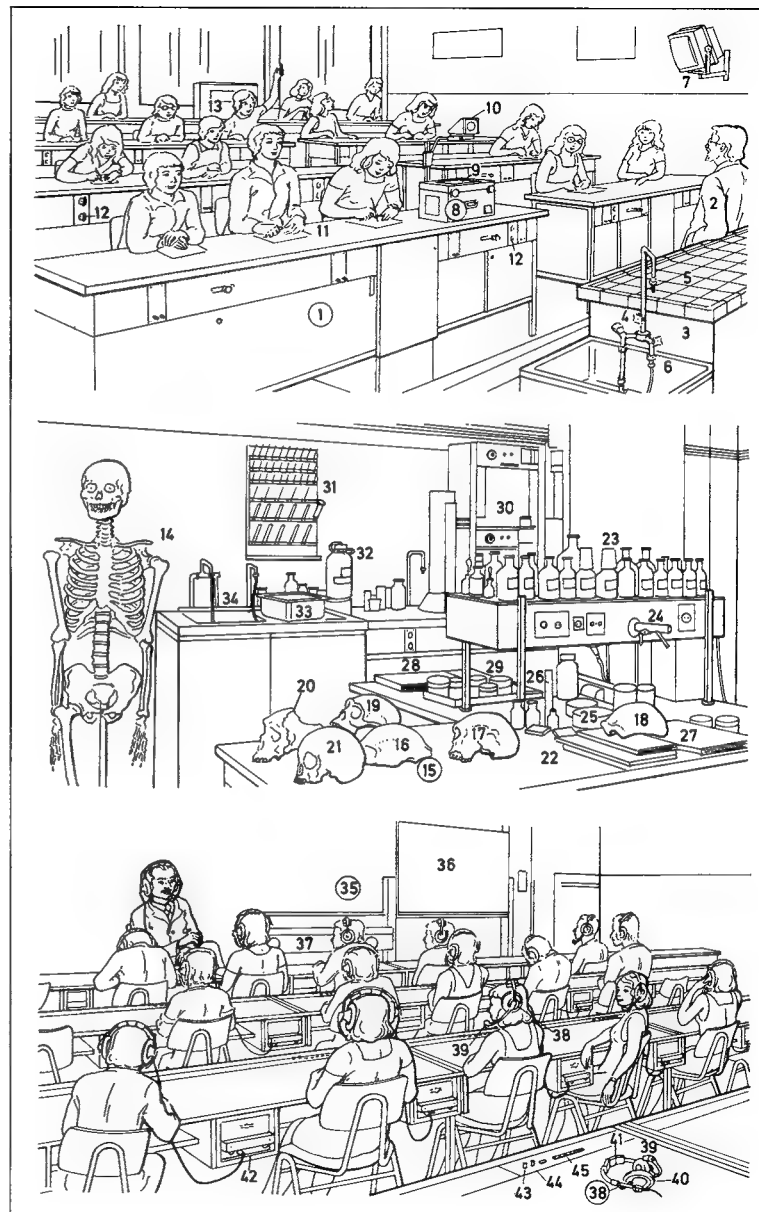

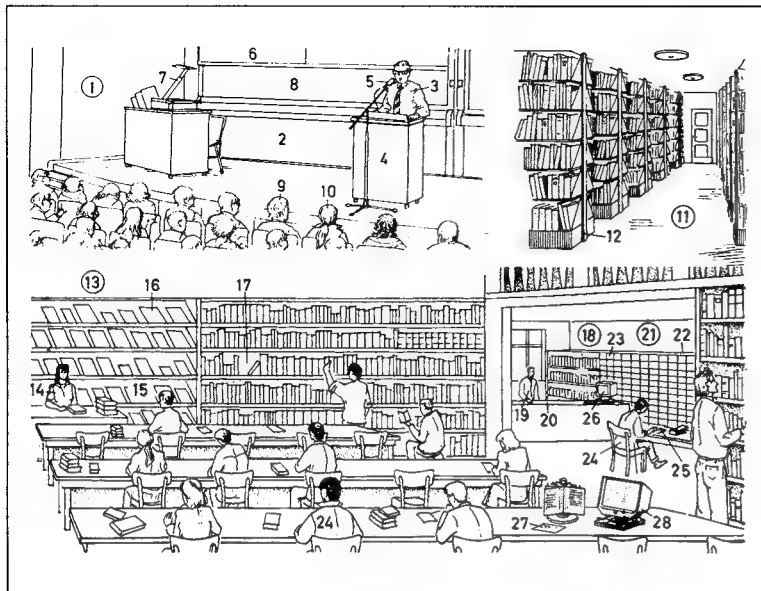
**1-28 university (college)**

- | | |
|--|---|
| <p>1 lecture</p> <p>2 lecture room (lecture theatre, <i>Am.</i> theater)</p> <p>3 university lecturer (lecturer, college lecturer, <i>Am.</i> assistant professor)</p> <p>4 lectern</p> <p>5 microphone</p> <p>6 remote-controlled blackboard</p> <p>7 overhead projector</p> <p>8 projection screen for projecting pictures by means of a film projector, slide projector, or an epidiastoscope</p> <p>9, 10 students</p> <p>11-28 university library; <i>sim.</i>: national library, regional or municipal scientific library</p> <p>11 stack (book stack) with the stock of books</p> <p>12 bookshelf, a steel shelf</p> <p>13 reading room</p> | <p>14 member of the reading room staff, a librarian</p> <p>15 periodicals rack with periodicals</p> <p>16 newspaper shelf</p> <p>17 reference library with reference books (handbooks, encyclopedias, dictionaries)</p> <p>18 lending library and catalogue (<i>Am.</i> catalog) room</p> <p>19 librarian</p> <p>20 issue desk</p> <p>21 main catalogue (<i>Am.</i> catalog)</p> <p>22 card catalogue (<i>Am.</i> catalog)</p> <p>23 card catalogue (<i>Am.</i> catalog) drawer</p> <p>24 library user</p> <p>25 borrower's ticket (library ticket)</p> <p>26 issue terminal</p> <p>27 microfiche (fiche)</p> <p>28 microfiche reader</p> |
|--|---|

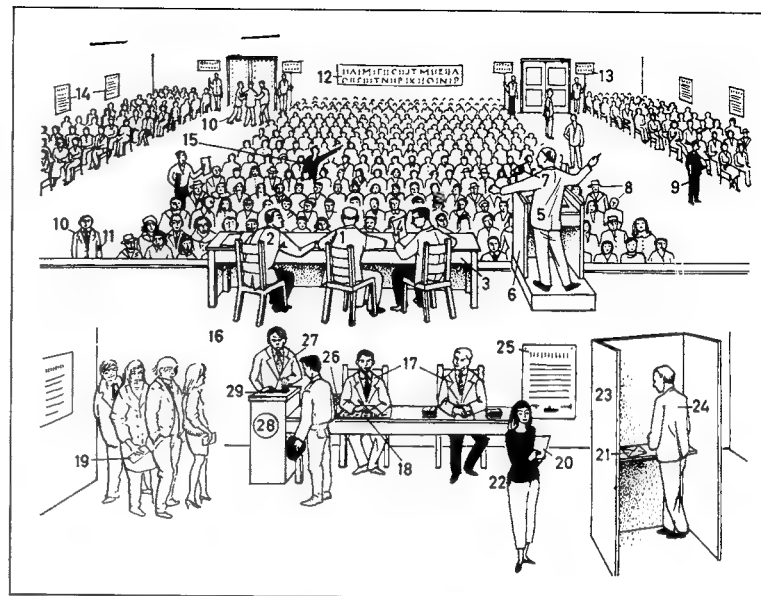
**1-15 election meeting, a public meeting**

- | | |
|--|--|
| <p>1, 2 committee</p> <p>1 chairman</p> <p>2 committee member</p> <p>3 committee table</p> <p>4 pamphlet</p> <p>5 election speaker (speaker)</p> <p>6 rostrum</p> <p>7 microphone</p> <p>8 meeting (audience)</p> <p>9 man distributing leaflets</p> <p>10 stewards</p> <p>11 armband (armlet)</p> <p>12 banner</p> <p>13 placard</p> <p>14 proclamation</p> <p>15 heckler</p> <p>16-29 election</p> <p>16 polling station (polling place)</p> <p>17 polling officers</p> <p>18 electoral list</p> | <p>19 polling card with registration number (polling number)</p> <p>20 ballot paper with the names of the parties and candidates</p> <p>21 ballot envelope</p> <p>22 voter</p> <p>23 polling booth</p> <p>24 elector (qualified voter)</p> <p>25 election regulations</p> <p>26 electoral register</p> <p>27 election supervisor</p> <p>28 ballot box</p> <p>29 slot</p> |
|--|--|

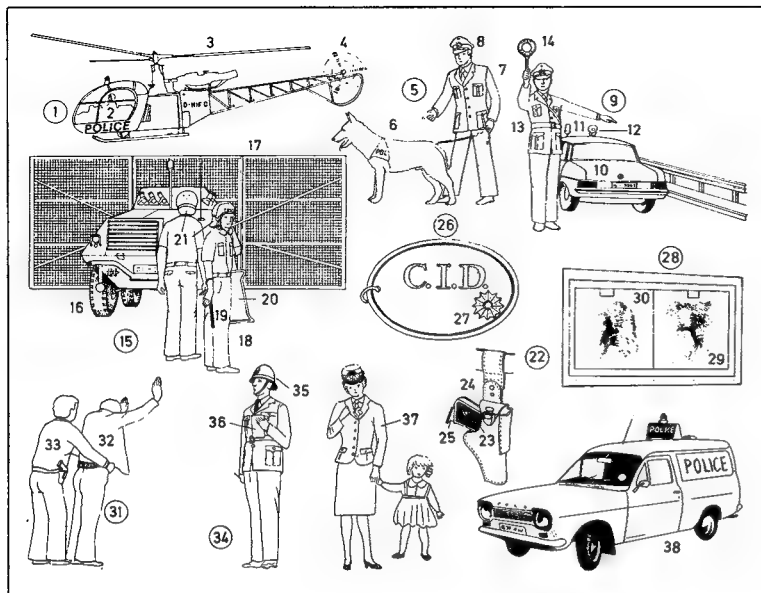
**1-33 police duties**

- 1 **police helicopter** (traffic helicopter) for controlling traffic from the air
 2 cockpit
 3 rotor (main rotor)
 4 tail rotor
 5 **use of police dogs**
 6 police dog
 7 uniform
 8 uniform cap, a peaked cap with cockade
 9 **traffic control** by a mobile traffic patrol
 10 patrol car
 11 blue light
 12 loud hailer (loudspeaker)
 13 patrolman (police patrolman)
 14 police signalling (*Am.* signaling) disc (disk)
 15 **riot duty**
 16 special armoured (*Am.* armored) car
 17 barricade
 18 policeman (police officer) in riot gear
 19 truncheon (baton)
 20 riot shield
 21 protective helmet (helmet)
 22 **service pistol**
 23 pistol grip
 24 quick-draw holster
 25 magazine
 26 **police identification disc (disk)**
 27 police badge
 28 **fingerprint identification** (dactyloscopy)
 29 fingerprint
 30 illuminated screen
 31 **search**
 32 suspect
 33 detective (plainclothes policeman)
 34 English policeman
 35 helmet
 36 pocket book
 37 policewoman
 38 police van

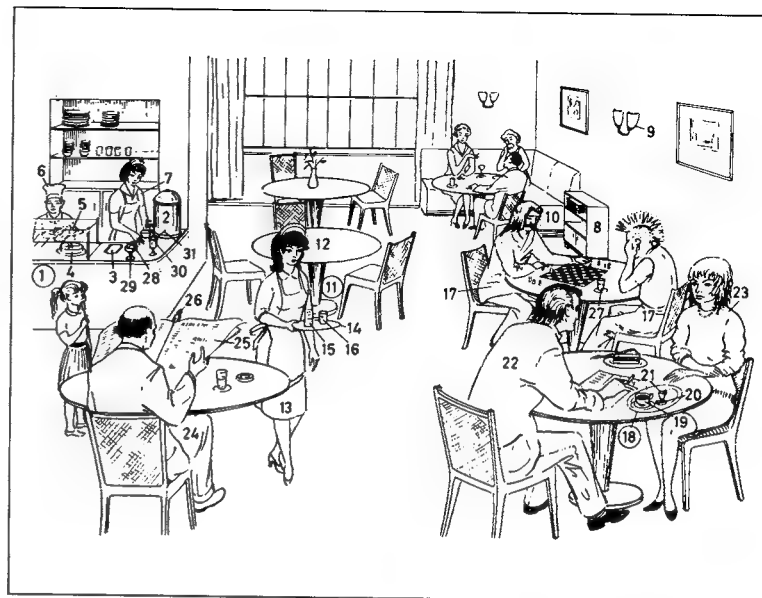

- 1-31 **café; sim.:** espresso bar, tea room, ice-cream parlour (*Am.* parlor)
 1 counter (cake counter)
 2 coffee urn
 3 tray for the money
 4 gâteau
 5 meringue with whipped cream
 6 trainee pastry cook
 7 counter assistant
 8 newspaper shelves (newspaper rack)
 9 wall lamp
 10 corner seat, an upholstered seat
 11 café table
 12 marble top
 13 waitress
 14 tray
 15 bottle of lemonade
 16 lemonade glass
 17 chess players playing a game of chess
 18 coffee set

- 19 cup of coffee
 20 small sugar bowl
 21 cream jug (*Am.* creamer)
 22-24 café customers
 22 gentleman
 23 lady
 24 man reading a newspaper
 25 newspaper
 26 newspaper holder
 27 espresso
 28 ice cream in assorted flavours (*Am.* flavors)
 29 ice-cream dish (sundae dish)
 30 iced coffee
 31 (drinking) straw

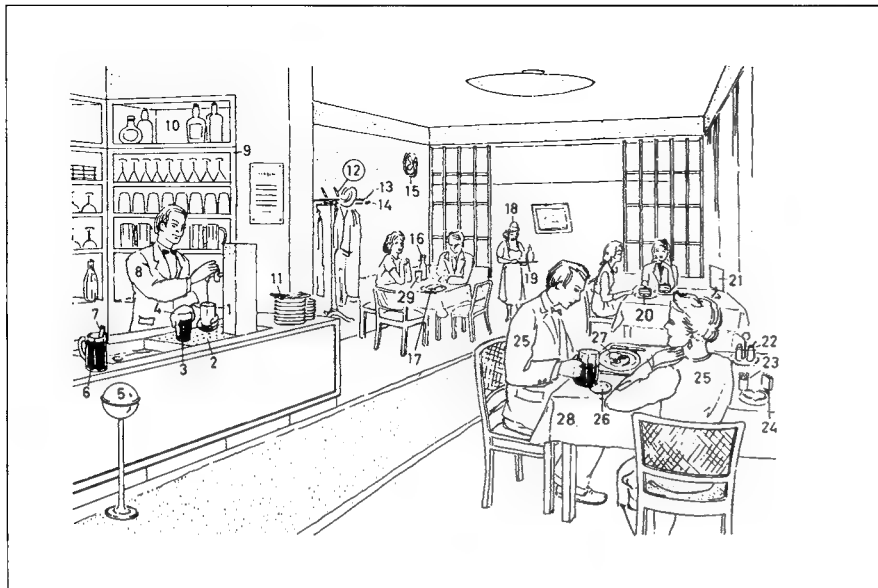
**1-27 restaurant****1-11 bar (counter)**

- 1 beer pump (beerpull)
- 2 drip tray
- 3 beer glass
- 4 froth (head)
- 5 spherical ashtray for cigarette and cigar ash
- 6 beer glass (beer mug)
- 7 beer warmer
- 8 bartender (barman, *Am.* barkeeper, barkeep)
- 9 shelf for glasses
- 10 shelf for bottles
- 11 stack of plates
- 12 coat stand
- 13 hat peg
- 14 coat hook
- 15 wall ventilator
- 16 bottle
- 17 complete meal
- 18 waitress
- 19 tray

20 dessert, a slice of cake**21 menu (menu card)**

- 22 cruet stand
- 23 toothpick holder
- 24 matchbox holder
- 25 customer
- 26 beer mat
- 27 meal of the day
- 28-44 wine restaurant (wine bar)**
- 28 tablecloth
- 29 glass of water
- 30 wine waiter, a head waiter
- 31 wine list
- 32 wine carafe
- 33 wineglass
- 34 tiled stove
- 35 stove tile
- 36 stove bench
- 37 wooden panelling (*Am.* paneling)
- 38 corner seat
- 39 table reserved for regular customers
- 40 regular customer

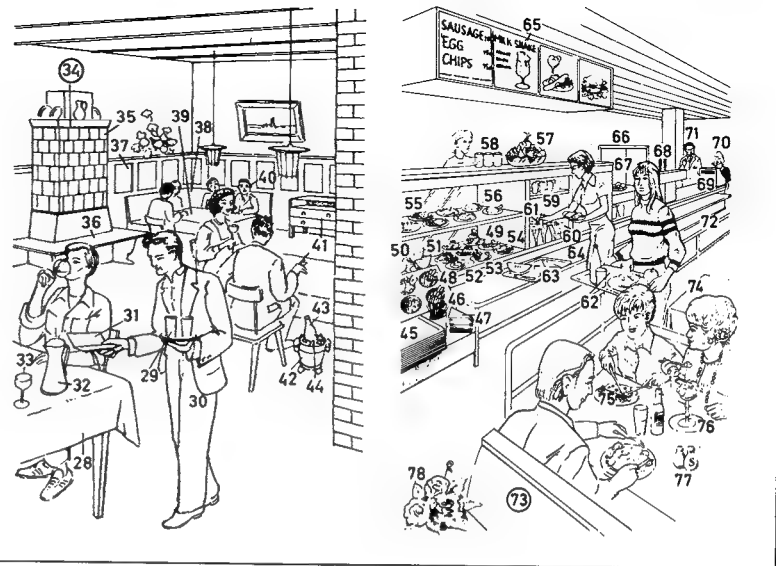
**41 cutlery chest****42 wine cooler****43 bottle of wine****44 ice cubes (ice, lumps of ice)****45-78 self-service restaurant**

- 45 stack of trays
- 46 drinking straws (straws)
- 47 serviettes (napkins)
- 48 cutlery holders
- 49 cool shelf
- 50 slice of honeydew melon
- 51 plate of salad
- 52 plate of cheeses
- 53 fish dish
- 54 filled roll
- 55 meat dish with trimmings
- 56 half chicken
- 57 basket of fruit
- 58 fruit juice
- 59 drinks shelf
- 60 bottle of milk
- 61 bottle of mineral water
- 62 vegetarian meal (diet meal)

63 tray**64 tray counter****65 food price list****66 serving hatch****67 hot meal****68 beer pump (beerpull)****69 cash desk****70 cashier****71 proprietor****72 rail****73 dining area****74 table****75 open sandwich****76 ice-cream sundae****77 salt cellar and pepper pot****78 table decoration (flower arrangement)**

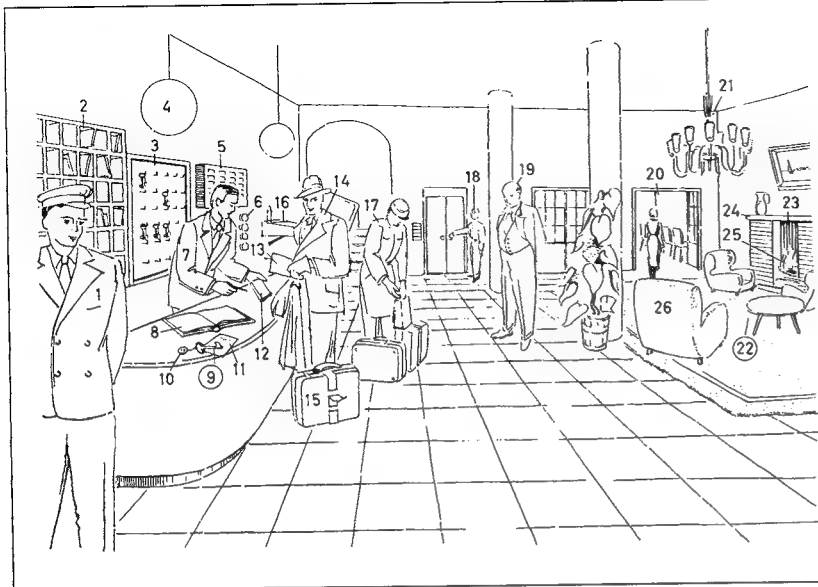
**1-26 vestibule** (foyer, reception hall)

- 1 doorman (commissionaire)
- 2 letter rack with pigeon holes
- 3 key rack
- 4 globe lamp, a frosted glass globe
- 5 indicator board
- 6 indicator light
- 7 chief receptionist
- 8 register (hotel register)
- 9 room key
- 10 number tag (number tab) showing room number
- 11 hotel bill
- 12 block of registration forms
- 13 passport
- 14 hotel guest
- 15 lightweight suitcase [for air travel]
- 16 wall desk
- 17 porter (*Am.* baggage man)
- 18-26 lobby (hotel lobby)
- 18 page (pageboy, *Am.* bell boy)
- 19 hotel manager
- 20 dining room (hotel restaurant)

21 chandelier

- 22 fireside
- 23 fireplace
- 24 mantelpiece (mantelshelf)
- 25 fire
- 26 armchair
- 27-38 **hotel room**, a double room with bath
- 27 double door
- 28 service bell panel
- 29 wardrobe (*Am.* clothes closet)
- 30 clothes compartment
- 31 linen compartment
- 32 double washbasin
- 33 room waiter
- 34 room telephone
- 35 velour (velours) carpet
- 36 flower stand
- 37 flower arrangement
- 38 double bed
- 39 **function room** (banqueting hall)
- 40-43 private party

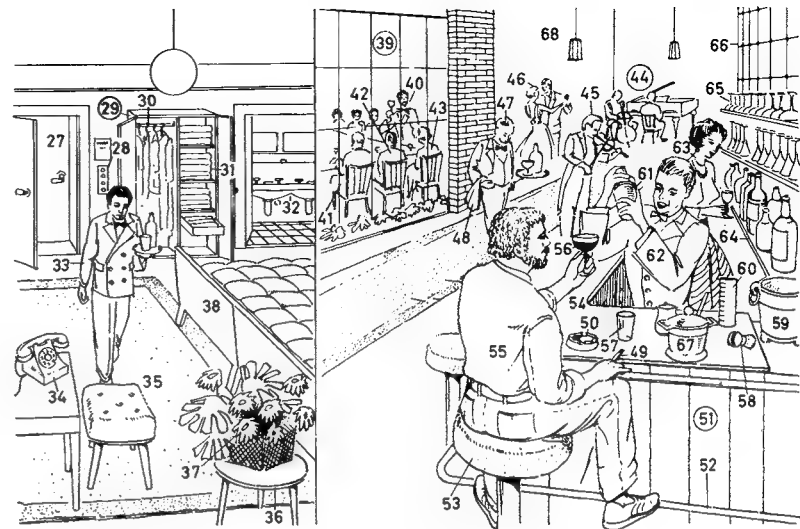
**40 speaker** proposing a toast

- 41 42's neighbour (*Am.* neighbor)
- 42 43's partner
- 43 42's partner
- 44 bar trio
- 45 violinist
- 46 couple dancing (dancing couple)
- 47 waiter
- 48 napkin
- 49 cigarette
- 50 ashtray
- 51 **hotel bar**
- 52 foot rail
- 53 bar stool
- 54 bar
- 55 bar customer
- 56 cocktail glass (*Am.* highball glass)
- 57 whisky (whiskey) glass
- 58 champagne cork
- 59 champagne bucket (champagne cooler)
- 60 measuring beaker (measure)
- 61 cocktail shaker

62 bartender (barman, *Am.* barkeeper, barkeep)

- 63 barmaid
- 64 shelf for bottles
- 65 shelf for glasses
- 66 mirrored panel
- 67 ice bucket
- 68 hotel foyer

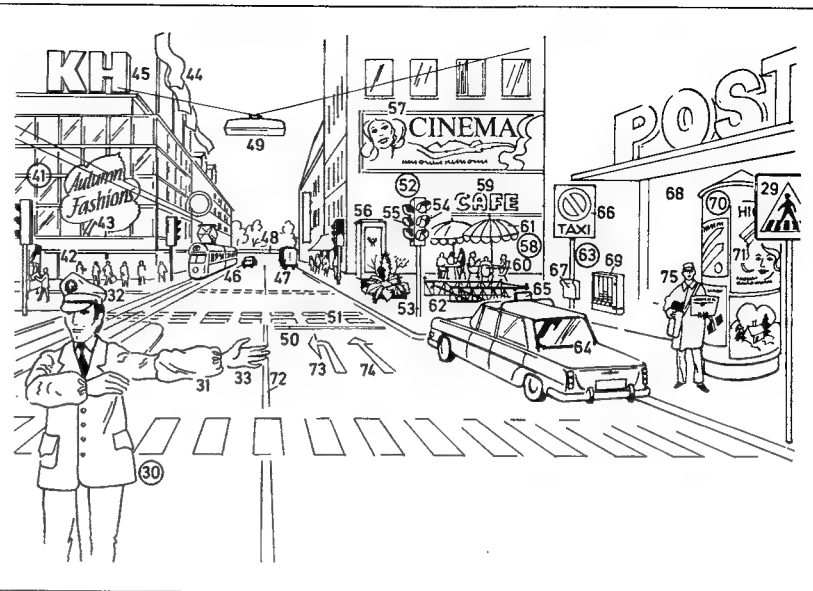
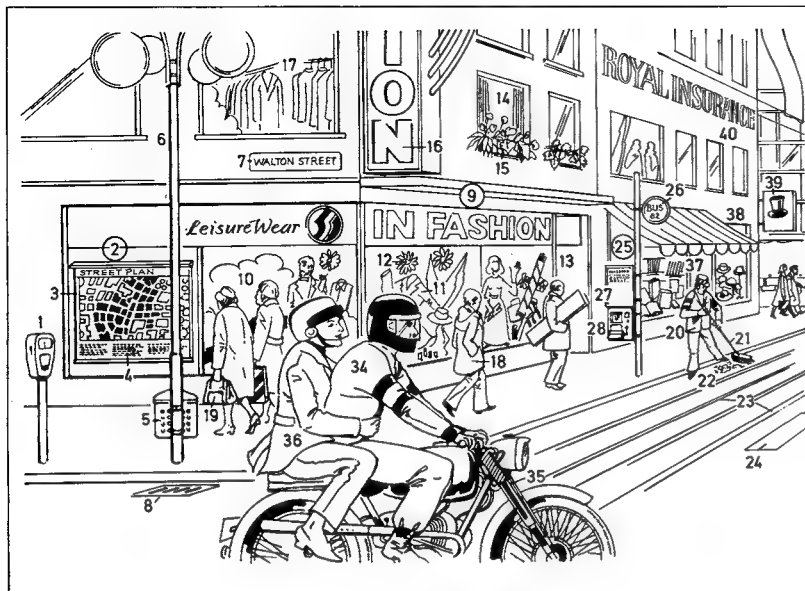

- 1 parking meter
- 2 map of the town (street map)
- 3 illuminated board
- 4 key
- 5 litter bin (*Am.* trash bin)
- 6 street lamp (street light)
- 7 street sign showing the name of the street
- 8 drain
- 9 clothes shop (fashion house)
- 10 shop window
- 11 window display (shop window display)
- 12 window decoration (shop window decoration)
- 13 entrance
- 14 window
- 15 window box
- 16 neon sign
- 17 tailor's workroom
- 18 pedestrian
- 19 shopping bag
- 20 road sweeper (*Am.* street sweeper)

- 21 broom
- 22 rubbish (litter)
- 23 tramlines (*Am.* streetcar tracks)
- 24 pedestrian crossing (zebra crossing, *Am.* crosswalk)
- 25 tram stop (*Am.* streetcar stop, trolley stop)
- 26 tram stop sign (*Am.* streetcar stop sign, trolley stop sign)
- 27 tram timetable (*Am.* streetcar schedule, trolley schedule)
- 28 ticket machine
- 29 'pedestrian crossing' sign
- 30 traffic policeman on traffic duty (point duty)
- 31 traffic control cuff
- 32 white cap
- 33 hand signal
- 34 motorcyclist
- 35 motorcycle
- 36 pillion passenger (pillion rider)
- 37 bookshop

- 38 hat shop (hatter's shop); *for ladies' hats*: milliner's shop
- 39 shop sign
- 40 insurance company office
- 41 department store
- 42 shop front
- 43 advertisement
- 44 flags
- 45 illuminated letters
- 46 tram (*Am.* streetcar, trolley)
- 47 furniture lorry (*Am.* furniture truck)
- 48 flyover
- 49 suspended street lamp
- 50 stop line
- 51 pedestrian crossing (*Am.* crosswalk)
- 52 traffic lights
- 53 traffic light post
- 54 set of lights
- 55 pedestrian lights
- 56 telephone box (telephone booth, telephone kiosk, call box)

- 57 cinema (*Am.* movie) advertisement (film poster, *Am.* movie poster)
- 58 pedestrian precinct (paved zone)
- 59 street café
- 60 group seated (sitting) at a table
- 61 sunshade
- 62 steps to the public lavatories (public conveniences)
- 63 taxi rank (taxi stand)
- 64 taxi (taxicab, cab)
- 65 taxi sign
- 66 'taxi rank' ('taxi stand') sign
- 67 taxi telephone
- 68 post office
- 69 cigarette machine
- 70 advertising pillar
- 71 poster (advertisement)
- 72 white line
- 73 lane arrow for turning left
- 74 lane arrow for going straight ahead
- 75 news vendor (*Am.* news dealer)

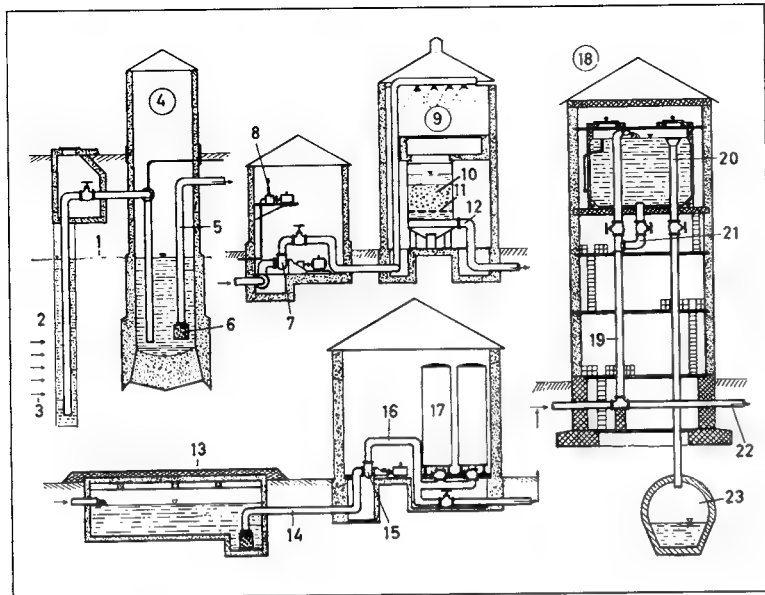

1-66 drinking water supply

- 1 water table (groundwater level)
- 2 water-bearing stratum (aquifer, aquafer)
- 3 groundwater stream (underground stream)
- 4 collector well for raw water
- 5 suction pipe
- 6 pump strainer with foot valve
- 7 bucket pump with motor
- 8 vacuum pump with motor
- 9 rapid-filter plant
- 10 filter gravel (filter bed)
- 11 filter bottom, a grid
- 12 filtered water outlet
- 13 purified water tank
- 14 suction pipe with pump strainer and foot valve
- 15 main pump with motor
- 16 delivery pipe
- 17 compressed-air vessel (air vessel, air receiver)
- 18 water tower

- 19 riser pipe (riser)
- 20 overflow pipe
- 21 outlet
- 22 distribution main
- 23 excess water conduit

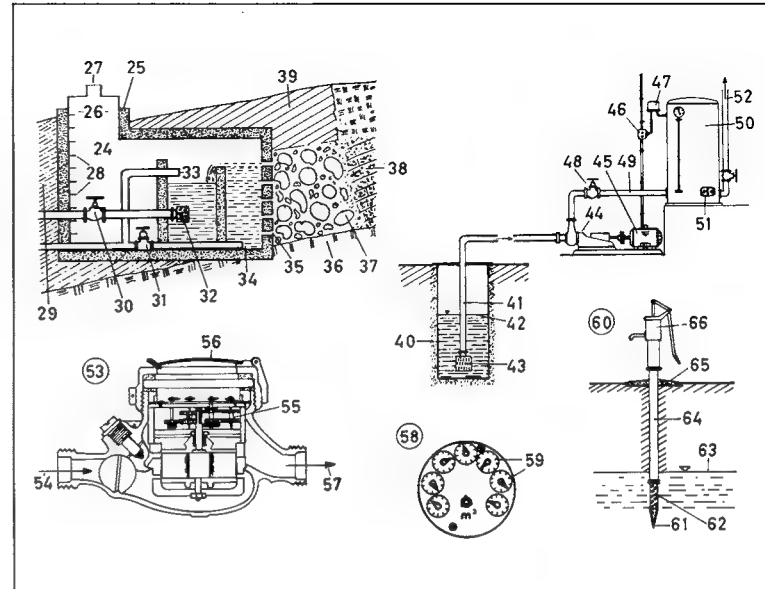

24-39 tapping a spring

- 24 chamber
 - 25 chamber wall
 - 26 manhole
 - 27 ventilator
 - 28 step irons
 - 29 filling (backing)
 - 30 outlet control valve
 - 31 outlet valve
 - 32 strainer
 - 33 overflow pipe (overflow)
 - 34 bottom outlet
 - 35 earthenware pipes
 - 36 impervious stratum (impermeable stratum)
 - 37 rough rubble
 - 38 water-bearing stratum (aquifer, aquafer)
 - 39 loam seal (clay seal)
- 40-52 individual water supply**
- 40 well
 - 41 suction pipe
 - 42 water table (groundwater level)
 - 43 pump strainer with foot valve

44 centrifugal pump

- 45 motor
 - 46 motor safety switch
 - 47 manostat, a switching device
 - 48 stop valve
 - 49 delivery pipe
 - 50 compressed-air vessel (air vessel, air receiver)
 - 51 manhole
 - 52 delivery pipe
- 53 water meter, a rotary meter**
- 54 water inlet
 - 55 counter gear assembly
 - 56 cover with glass lid
 - 57 water outlet
- 58 water-meter dial**
- 59 counters
- 60 driven well (tube well, drive well)**
- 61 pile shoe
 - 62 filter
 - 63 water table (groundwater level)
 - 64 well casing
 - 65 well head
 - 66 hand pump

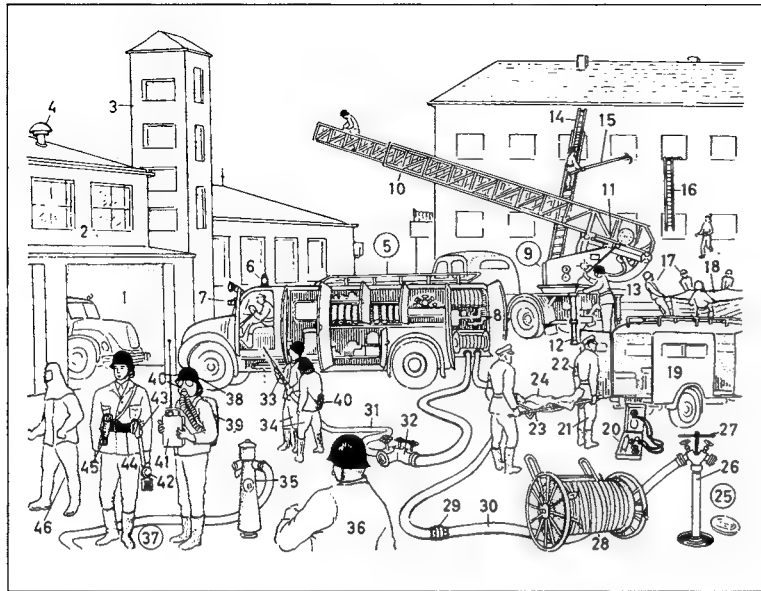

- 1-46 fire service drill (extinguishing, climbing, ladder, and rescue work)
 1-3 fire station
 1 engine and appliance room
 2 firemen's (*Am.* firefighters') quarters
 3 drill tower
 4 fire alarm (fire alarm siren, fire siren)
 5 fire engine
 6 blue light (warning light), a flashing light (*Am.* flashlight)
 7 horn (hooter)
 8 motor pump, a centrifugal pump
 9 motor turntable ladder (*Am.* aerial ladder)
 10 ladder, a steel ladder (automatic extending ladder)
 11 ladder mechanism
 12 jack
 13 ladder operator
 14 extension ladder
 15 ceiling hook (*Am.* preventer)
 16 hook ladder (*Am.* pompier ladder)
 17 holding squad
 18 jumping sheet (sheet)
 19 ambulance car (ambulance)
 20 resuscitator (resuscitation equipment), oxygen apparatus
 21 ambulance attendant (ambulance man)
 22 armband (armlet, brassard)
 23 stretcher
 24 unconscious man
 25 pit hydrant
 26 standpipe (riser, vertical pipe)
 27 hydrant key
 28 hose reel (*Am.* hose cart, hose wagon, hose truck, hose carriage)
 29 hose coupling
 30 soft suction hose
 31 delivery hose
 32 dividing breeching
 33 branch
 34 branchmen
 35 surface hydrant (fire plug)
 36 officer in charge
 37 fireman (*Am.* firefighter)
 38 helmet (fireman's helmet, *Am.* fire hat) with neck guard (neck flap)
 39 breathing apparatus
 40 face mask
 41 walkie-talkie set
 42 hand lamp
 43 small axe (*Am.* ax, pompier hatchet)
 44 hoot belt
 45 beltline
 46 protective clothing of asbestos (asbestos suit) or of metallic fabric

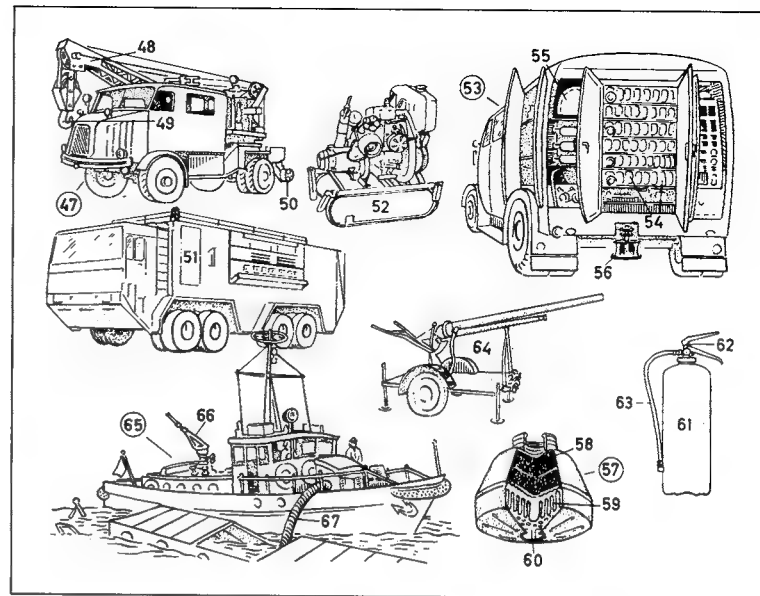

- 47 breakdown lorry (*Am.* crane truck, wrecking crane)
 48 lifting crane
 49 load hook (draw hook, *Am.* drag hook)
 50 support roll
 51 water tender
 52 portable pump
 53 hose layer
 54 flaked lengths of hose
 55 cable drum
 56 winch
 57 face mask filter
 58 active carbon (activated carbon, activated charcoal)
 59 dust filter
 60 air inlet
 61 portable fire extinguisher
 62 operating valve
 63 hose with spray nozzle
 64 foam-making branch (*Am.* foam gun)
 65 fireboat
 66 monitor (water cannon)
 67 suction hose

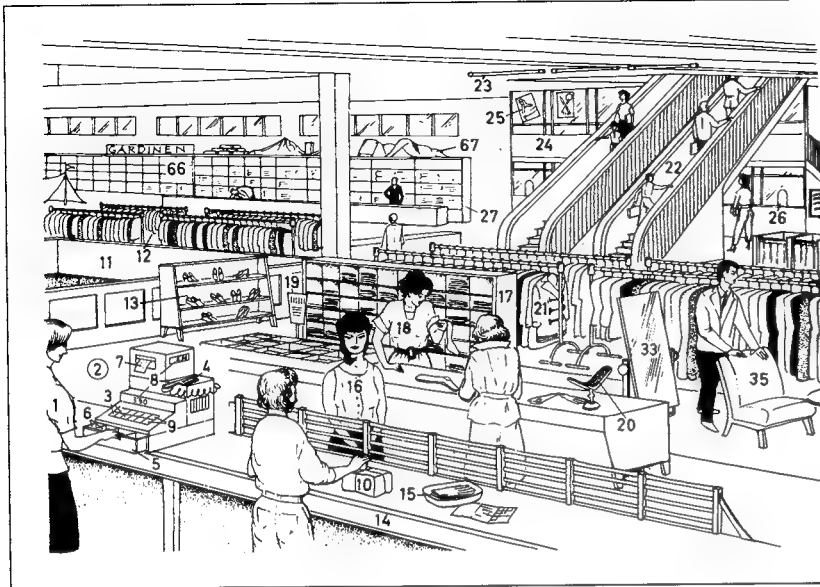

- | | |
|---|--|
| 1 cashier | 19 price card |
| 2 electronic cash register (till) (scanner till) | 20 glove stand |
| 3 number keys | 21 duffle coat, a three-quarter length coat |
| 4 scanner (light pen) | 22 escalator |
| 5 cash drawer (till) | 23 fluorescent light (fluorescent lamp) |
| 6 compartments (money compartments) for coins and notes (<i>Am.</i> bills) | 24 office (<i>e.g.</i> customer accounts office, travel agency, manager's office) |
| 7 receipt (sales check) | 25 poster (advertisement) |
| 8 amount [to be paid] | 26 theatre (<i>Am.</i> theater) and concert booking office (advance booking office) |
| 9 function keys | 27 shelves |
| 10 goods | 28 ladies' wear department |
| 11 glass-roofed well | 29 ready-made dress (ready-to-wear dress, <i>coll.</i> off-the-peg dress) |
| 12 men's wear department | 30 dust cover |
| 13 showcase (display case, indoor display window) | 31 clothes rack |
| 14 wrapping counter | 32 changing booth (fitting booth) |
| 15 tray for purchases | 33 mirror |
| 16 customer | 34 dummy |
| 17 hosiery department | 35 seat (chair) |
| 18 shop assistant (<i>Am.</i> salesgirl, saleslady) | |

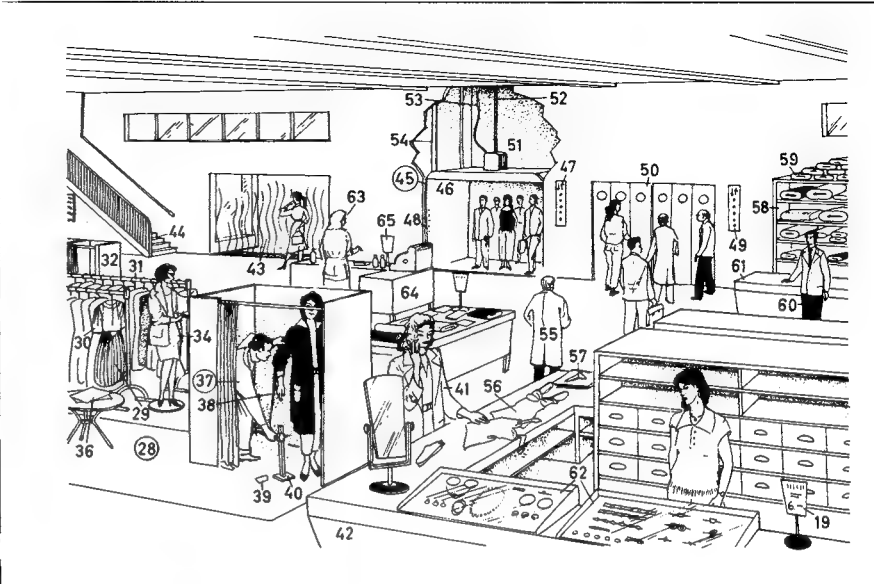

- | | |
|---|---|
| 36 fashion journal (fashion magazine) | 57 linen goods (table linen and bed linen) |
| 37 tailor marking a hemline | 58 fabric department |
| 38 measuring tape (tape measure) | 59 roll of fabric (roll of material, roll of cloth) |
| 39 tailor's chalk (<i>French</i> chalk) | 60 head of department (department manager) |
| 40 hemline marker | 61 sales counter |
| 41 loose-fitting coat | 62 jewellery (<i>Am.</i> jewelry) department |
| 42 sales counter | 63 customer assistant |
| 43 warm-air curtain | 64 special counter (extra counter) |
| 44 stairs | 65 placard advertising special offers |
| 45 lift (<i>Am.</i> elevator) | 66 curtain department |
| 46 lift cage (lift car, <i>Am.</i> elevator car) | 67 display on top of the shelves |
| 47 direction indicators | |
| 48 controls (lift controls, <i>Am.</i> elevator controls) | |
| 49 floor indicator | |
| 50 sliding door | |
| 51 lift shaft (<i>Am.</i> elevator shaft) | |
| 52 bearer cable | |
| 53 control cable | |
| 54 guide rail | |
| 55 customer | |
| 56 hosiery | |

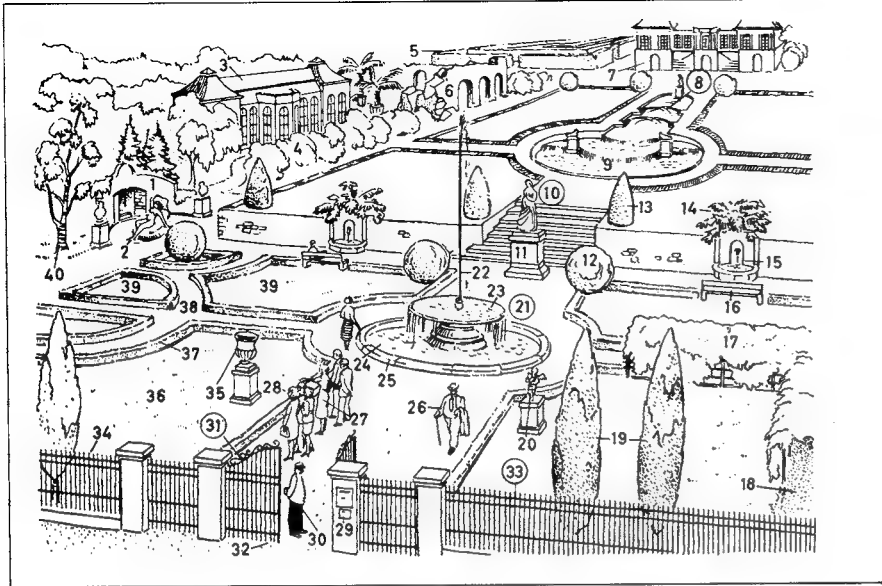

1-40 formal garden (French Baroque garden), palace gardens

- 1 grotto (cavern)
- 1 stone statue, a river nymph
- 3 orangery (orangerie)
- 4 boschage (boskage)
- 5 maze (labyrinth of paths and hedges)
- 6 open-air theatre (*Am.* theater)
- 7 Baroque palace
- 8 fountains
- 9 cascade (broken artificial waterfall, artificial falls)
- 10 statue, a monument
- 11 pedestal
- 12 globe-shaped tree
- 13 conical tree
- 14 ornamental shrub
- 15 wall fountain
- 16 park bench
- 17 pergola (bower, arbour, *Am.* arbor)
- 18 gravel path (gravel walk)
- 19 pyramid tree (pyramidal tree)
- 20 cupid (cherub, amoretto, amorino)
- 21 fountain
- 22 fountain
- 23 overflow basin
- 24 basin
- 25 kerb (curb)
- 26 man out for a walk
- 27 tourist guide
- 28 group of tourists
- 29 park by-laws (bye-laws)
- 30 park keeper
- 31 garden gates made of wrought iron
- 32 park entrance
- 33 park railings
- 34 railing (bar)
- 35 stone vase
- 36 lawn
- 37 border, a trimmed (clipped) hedge
- 38 park path
- 39 parterre
- 40 birch (birch tree)

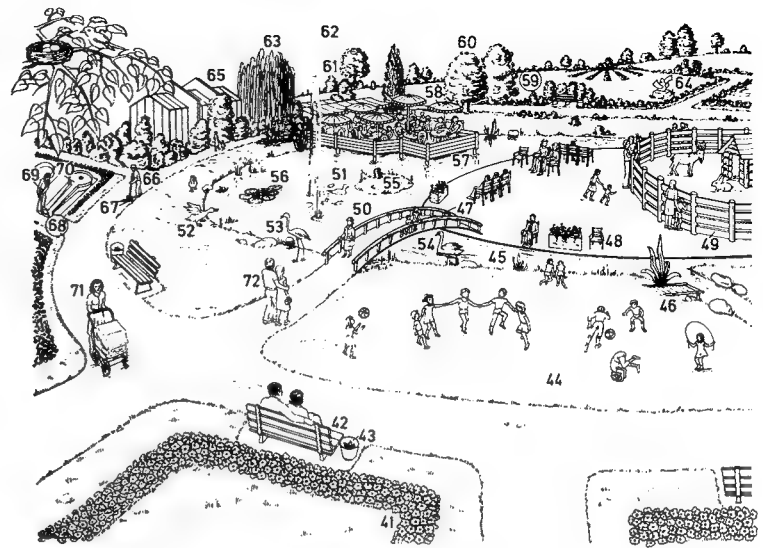

41-72 landscaped park (jardin anglais)

- 41 flower bed
- 42 park bench (garden seat)
- 43 litter bin (*Am.* trash bin)
- 44 play area
- 45 stream
- 46 jetty
- 47 bridge
- 48 park chair
- 49 animal enclosure
- 50 pond
- 51-54 waterfowl
- 51 wild duck with young
- 52 goose
- 53 flamingo
- 54 swan
- 55 island
- 56 water lily
- 57 open-air café
- 58 sunshade
- 59 park tree (tree)
- 60 treetop (crown)
- 61 group of trees
- 62 fountain
- 63 weeping willow
- 64 modern sculpture
- 65 hothouse
- 66 park gardener
- 67 broom
- 68 minigolf course
- 69 minigolf player
- 70 minigolf hole
- 71 mother with pram (baby carriage)
- 72 courting couple (young couple)

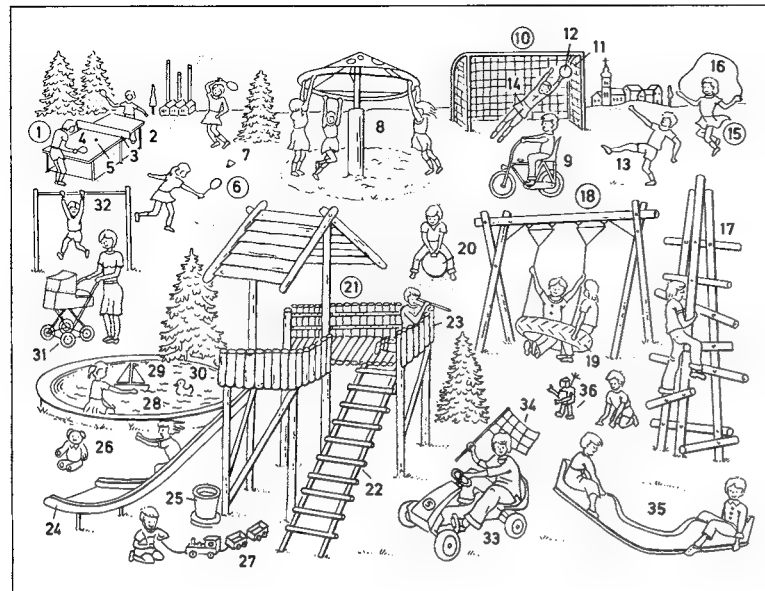

- | | |
|---|---|
| 1 table tennis | 21 adventure playground |
| 2 table | 22 log ladder |
| 3 table tennis net | 23 lookout platform |
| 4 table tennis racket (raquet) (table tennis bat) | 24 slide |
| 5 table tennis ball | 25 litter bin (<i>Am.</i> trash bin) |
| 6 badminton game (shuttlecock game) | 26 teddy bear |
| 7 shuttlecock | 27 wooden train set |
| 8 maypole swing | 28 paddling pool |
| 9 child's bicycle | 29 sailing boat (<i>yacht, Am.</i> sailboat) |
| 10 football (soccer) | 30 toy duck |
| 11 goal (goalposts) | 31 pram (baby carriage) |
| 12 football | 32 high bar (bar) |
| 13 goal scorer | 33 go-cart (soap box) |
| 14 goalkeeper | 34 starter's flag |
| 15 skipping (<i>Am.</i> jumping rope) | 35 seesaw |
| 16 skipping rope (<i>Am.</i> skip rope, jump rope, jumping rope) | 36 robot |
| 17 climbing tower | |
| 18 rubber tyre (<i>Am.</i> tire) swing | |
| 19 lorry tyre (<i>Am.</i> truck tire) | |
| 20 bouncing ball | |

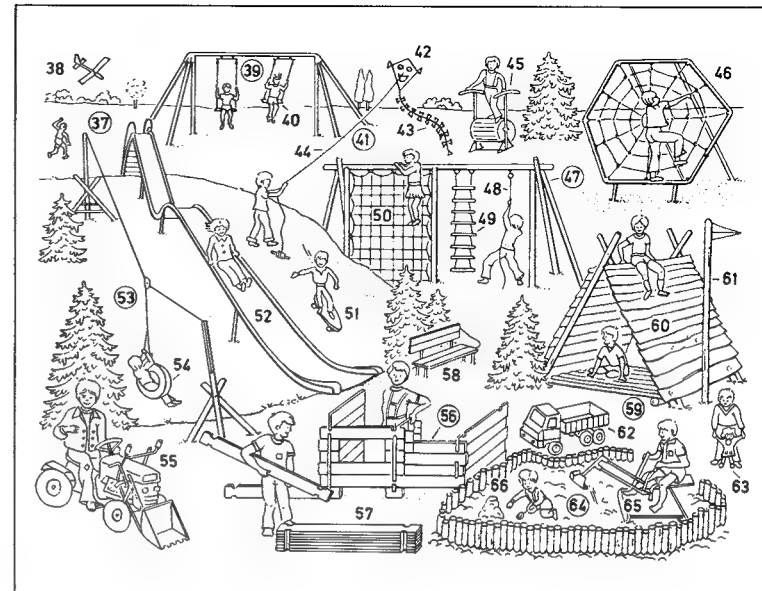

- | | |
|---|--------------------------------------|
| 37 flying model aeroplanes (<i>Am.</i> air-planes) | 60 climbing roof |
| 38 model aeroplane (<i>Am.</i> airplane) | 61 flagpole (flagstaff) |
| 39 double swing | 62 toy lorry (<i>Am.</i> toy truck) |
| 40 swing seat | 63 walking doll |
| 41 flying kites | 64 sandpit (<i>Am.</i> sandbox) |
| 42 kite | 65 toy excavator (toy digger) |
| 43 tail of the kite | 66 sandhill |
| 44 kite string | |
| 45 revolving drum | |
| 46 spider's web | |
| 47 climbing frame | |
| 48 climbing rope | |
| 49 rope ladder | |
| 50 climbing net | |
| 51 skateboard | |
| 52 up-and-down slide | |
| 53 rubber tyre (<i>Am.</i> tire) cable car | |
| 54 rubber tyre (<i>Am.</i> tire) | |
| 55 tractor, a pedal car | |
| 56 den | |
| 57 presawn boards | |
| 58 seat (bench) | |
| 59 Indian hut | |

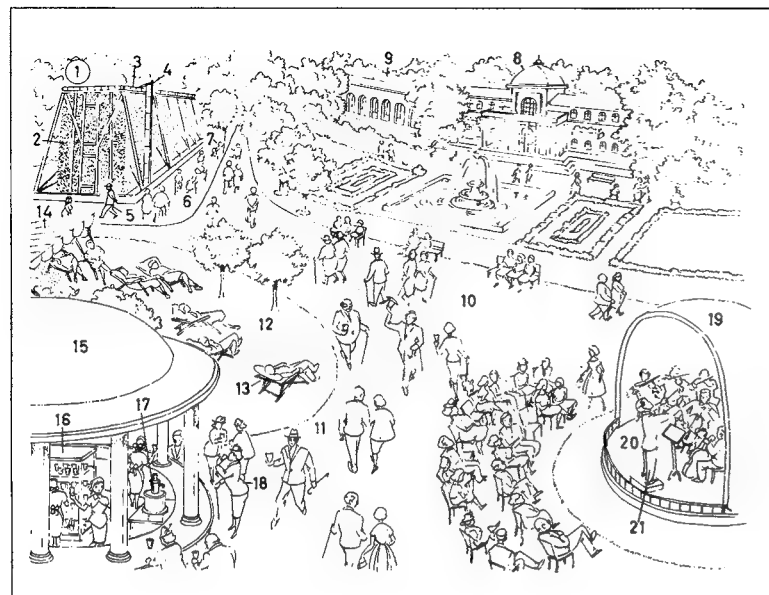

- 1-21 spa gardens
 1-7 salina (salt works)
 1 thorn house (graduation house)
 2 thorns (brushwood)
 3 brine channels
 4 brine pipe from the pumping station
 5 salt works attendant
 6, 7 inhalational therapy
 6 open-air inhalatorium (outdoor inhalatorium)
 7 patient inhaling (taking an inhalation)
 8 hydrophatic (pump room) with kursaal (casino)
 9 colonnade
 10 spa promenade
 11 avenue leading to the mineral spring
 12-14 rest cure
 12 sunbathing area (lawn)
 13 deck-chair
 14 sun canopy
 15 pump room
 16 rack for glasses
 17 tap
 18 patient taking the waters
 19 bandstand
 20 spa orchestra giving a concert
 21 conductor

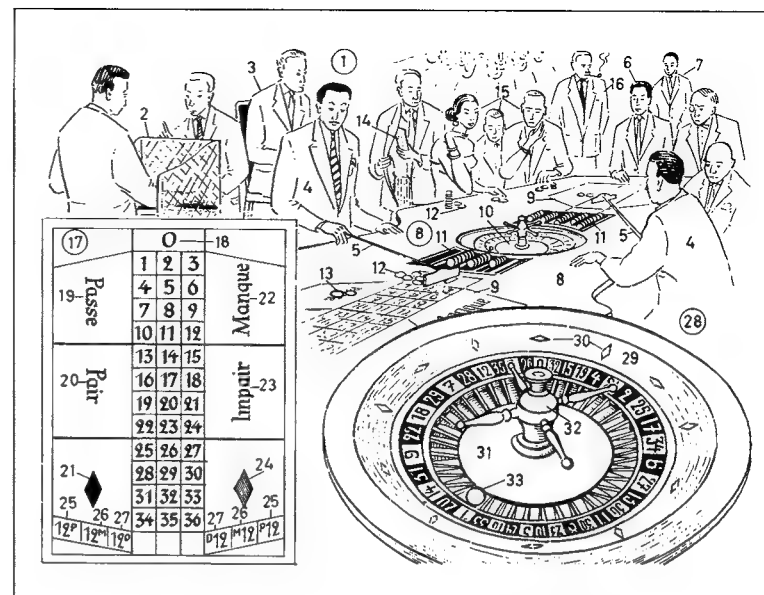

- 1-33 roulette, a game of chance (gambling game)
 1 gaming room in the casino (in the gambling casino)
 2 cash desk
 3 tourneur (dealer)
 4 croupier
 5 rake
 6 head croupier
 7 hall manager
 8 roulette table (gaming table, gambling table)
 9 roulette layout
 10 roulette wheel
 11 bank
 12 chip (check, plaque)
 13 stake
 14 membership card
 15 roulette player
 16 private detective (house detective)
 17 roulette layout
 18 zero (nought, 0)
 19 passe (high) [numbers 19 to 36]
 20 pair (even numbers)
 21 noir (black)
 22 manque (low) [numbers 1 to 18]
 23 impair [odd numbers]
 24 rouge (red)
 25 douze premier (first dozen) [numbers 1 to 12]
 26 douze milieu (second dozen) [numbers 13 to 24]
 27 douze dernier (third dozen) [numbers 25 to 36]
 28 roulette wheel (roulette)
 29 roulette bowl
 30 fret (separator)
 31 revolving disc (disk) showing numbers 0 to 36
 32 spin
 33 roulette ball

- 1-16 chess, a game involving combinations of moves, a positional game
- 1 chessboard (board) with the men (chessmen) in position
- 2 white square (chessboard square)
- 3 black square
- 4 white chessmen (white pieces) [white = W]
- 5 black chessmen (black pieces) [black = B]
- 6 letters and numbers for designating chess squares in the notation of chess moves and chess problems
- 7 individual chessmen (individual pieces)
- 8 king
- 9 queen
- 10 bishop
- 11 knight
- 12 rook (castle)
- 13 pawn
- 14 moves of the individual pieces
- 15 mate (checkmate), a mate by knight
- 16 chess clock, a double clock for chess matches (chess championships)
- 17-19 draughts (*Am.* checkers)
- 17 draughtboard (*Am.* checkerboard)
- 18 white draughtsman (*Am.* checker, checkerman); *also:* piece for backgammon and nine men's morris
- 19 black draughtsman (*Am.* checker, checkerman)
- 20 salta
- 21 salta piece
- 22 backgammon board
- 23-25 nine men's morris
- 23 nine men's morris board
- 24 mill
- 25 double mill
- 26-28 halma
- 26 halma board
- 27 yard (camp, corner)
- 28 halma pieces (halma men) of vari-

- ous colours (*Am.* colors)
- 29 dice (dicing)
- 30 dice cup
- 31 dice
- 32 spots (pips)
- 33 dominoes
- 34 domino (tile)
- 35 double
- 36 playing cards
- 37 playing card (card)
- 38-45 suits
- 38 clubs
- 39 spades
- 40 hearts
- 41 diamonds
- 42-45 German suits
- 42 acorns
- 43 leaves
- 44 hearts
- 45 bells (hawkbells)

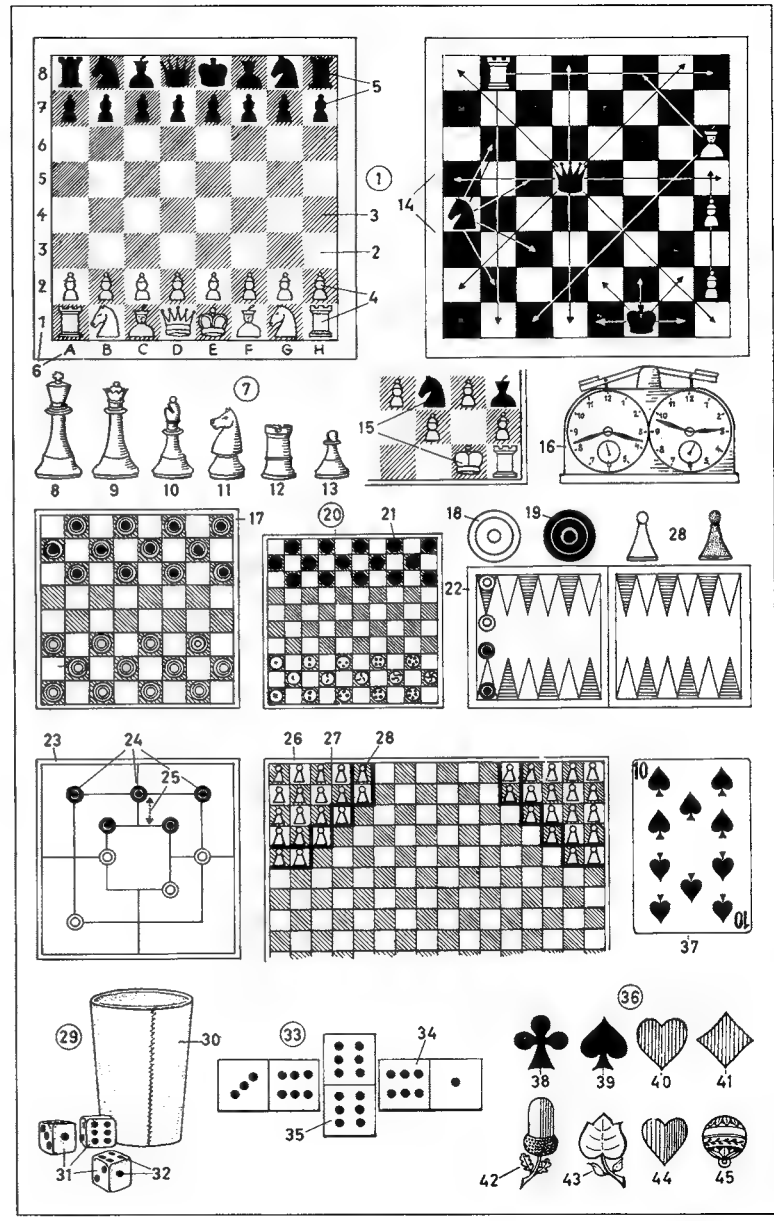

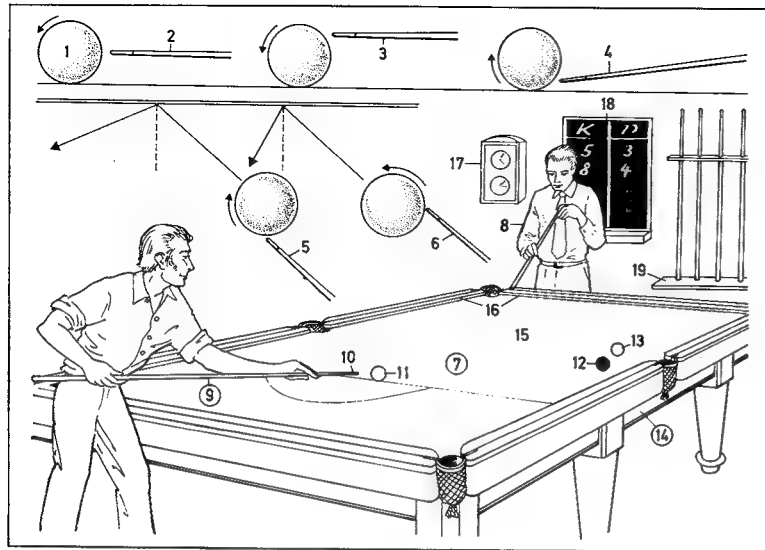
**1-19 billiards**

- 1 billiard ball, an ivory or plastic ball
- 2-6 billiard strokes
- 2 plain stroke (hitting the cue ball dead centre, *Am.* center)
- 3 top stroke [promotes extra forward rotation]
- 4 screw-back [imparts a direct recoil or backward motion]
- 5 side (running side, *Am.* English)
- 6 check side
- 7-19 billiard room (*Am.* billiard parlor, billiard saloon, poolroom)
- 7 billiards (English billiards); *sim.*: pool, carrom (carrom billiards)
- 8 billiard player
- 9 cue (billiard cue)
- 10 leather cue tip
- 11 white cue ball
- 12 red object ball
- 13 white spot ball (white dot ball)
- 14 billiard table
- 15 table bed with green cloth (billiard cloth, green baize covering)

16 cushions (rubber cushions, cushioned ledge)

- 17 billiard clock, a timer
- 18 billiard marker
- 19 cue rack

**1-59 camp site (camping site, *Am.* campground)**

- | | | |
|--|---|------------------------------------|
| 1 reception (office) | 17 thwart (oarsman's bench) | 36 frame tent |
| 2 site warden | 18 rowlock (oarlock) | 37 awning |
| 3 folding trailer (collapsible caravan, collapsible trailer) | 19 oar | 38 tent pole |
| 4 hammock | 20 boat trailer (boat carriage) | 39 wheelarch doorway |
| 5, 6 washing and toilet facilities | 21 ridge tent | 40 mesh ventilator |
| 5 toilets and washrooms (<i>Am.</i> lavatories) | 22 flysheet | 41 transparent window |
| 6 washbasins and sinks | 23 guy line (guy) | 42 pitch number |
| 7 bungalow (chalet) | 24 tent peg (peg) | 43 folding camp chair |
| 8-11 scout camp | 25 mallet | 44 folding camp table |
| 8 bell tent | 26 groundsheet ring | 45 camping eating utensils |
| 9 pennon | 27 bell end | 46 camper |
| 10 camp fire | 28 erected awning | 47 charcoal grill (barbecue) |
| 11 boy scout (scout) | 29 storm lantern, a paraffin lamp | 48 charcoal |
| 12 sailing boat (yacht, <i>Am.</i> sailboat) | 30 sleeping bag | 49 bellows |
| 13 landing stage (jetty) | 31 air mattress (inflatable air-bed) | 50 roof rack |
| 14 inflatable boat (inflatable dinghy) | 32 water carrier (drinking water carrier) | 51 roof lashing |
| 15 outboard motor (outboard) | 33 double-burner gas cooker for propane gas or butane gas | 52 caravan (<i>Am.</i> trailer) |
| 16 trimaran | 34 propane or butane gas bottle | 53 box for gas bottle |
| | 35 pressure cooker | 54 jockey wheel |
| | | 55 drawbar coupling |
| | | 56 roof ventilator |
| | | 57 caravan awning |
| | | 58 inflatable igloo tent |
| | | 59 camp bed (<i>Am.</i> camp cot) |

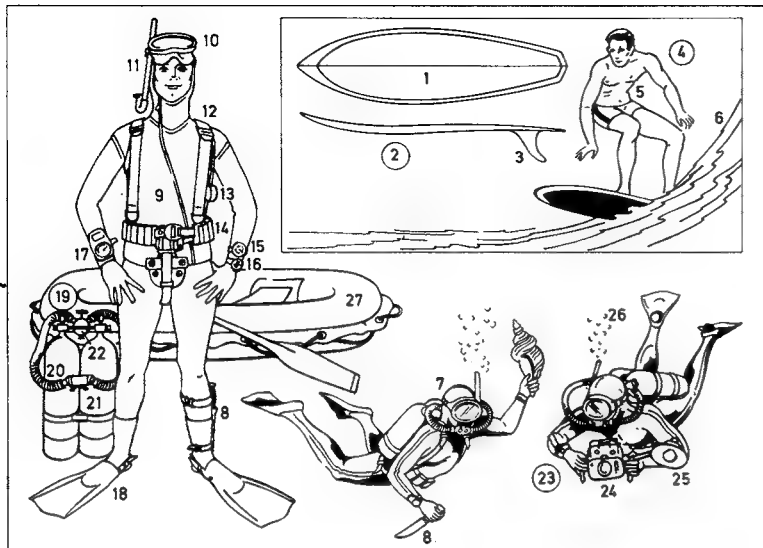

- 1-6 surf riding (surfing)
 1 plan view of surfboard
 2 section of surfboard
 3 skeg (stabilizing fin)
 4 big wave riding
 5 surfboarder (surfer)
 6 breaker
 7-27 skin diving (underwater swimming)
 7 skin diver (underwater swimmer)
 8-22 underwater swimming set
 8 knife
 9 neoprene wetsuit
 10 diving mask (face mask, mask), a pressure-equalizing mask
 11 snorkel (schnorkel)
 12 harness of diving apparatus
 13 compressed-air pressure gauge (Am. gage)
 14 weight belt
 15 depth gauge (Am. gage)
 16 waterproof watch for checking duration of dive
 17 decometer for measuring stages of ascent
 18 fin (flipper)
 19 diving apparatus (aqualung, scuba) with two cylinders (bottles)
 20 two-tube demand regulator
 21 compressed-air cylinder (compressed-air bottle)
 22 on/off valve
 23 underwater photography
 24 underwater camera
 25 underwater flashlight
 26 exhaust bubbles
 27 inflatable boat (inflatable dinghy)

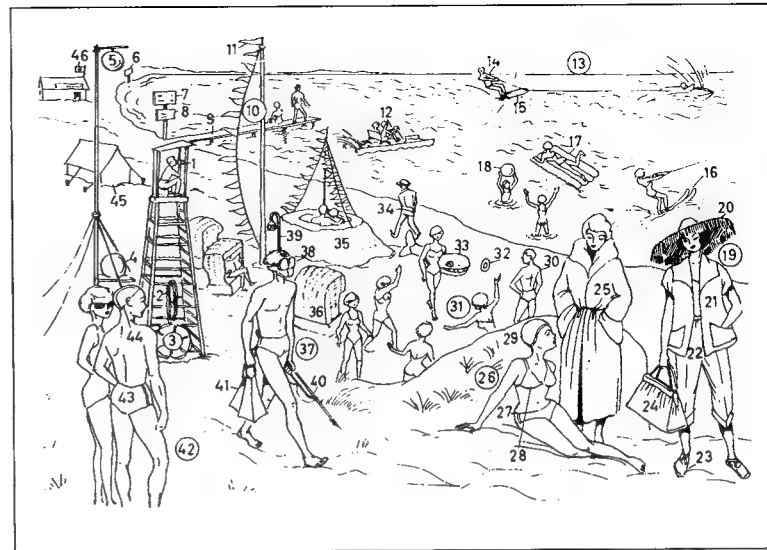

- 1 lifeguard (lifeguard)
 2 lifeline
 3 lifebelt (lifebuoy)
 4 storm signal
 5 time ball
 6 warning sign
 7 tide table, a notice board showing times of low tide and high tide
 8 board showing water and air temperature
 9 bathing platform
 10 pennon staff
 11 pennon
 12 paddle boat (pedal boat)
 13 surf riding (surfing) behind motorboat
 14 surfboarder (surfer)
 15 surfboard
 16 water ski
 17 inflatable beach mattress
 18 beach ball
 19-23 beachwear
 19 beach suit
 20 beach hat
 21 beach jacket
 22 beach trousers
 23 beach shoe (bathing shoe)
 24 beach bag
 25 bathing gown (bathing wrap)
 26 bikini (ladies' two-piece bathing suit)
 27 bikini bottom
 28 bikini top
 29 bathing cap (swimming cap)
 30 bather
 31 deck tennis (quoits)
 32 rubber ring (quoit)
 33 inflatable rubber animal
 34 beach attendant
 35 sandcastle
 36 roofed wicker beach chair
 37 underwater swimmer
 38 diving goggles
 39 snorkel (schnorkel)
 40 hand harpoon (fish spear, fish lance)
 41 fin (flipper) for diving (for underwater swimming)
 42 bathing suit (swimsuit)
 43 bathing trunks (swimming trunks)
 44 bathing cap (swimming cap)
 45 beach tent, a ridge tent
 46 lifeguard station

- 1-9 wave pool, an indoor pool
- 1 artificial waves
- 2 beach area
- 3 edge of the pool
- 4 swimming pool attendant (pool attendant, swimming bath attendant)
- 5 sun bed
- 6 lifebelt
- 7 water wings
- 8 bathing cap
- 9 channel to outdoor mineral bath
- 10 solarium
- 11 sunbathing area
- 12 sunbather
- 13 sun ray lamp
- 14 bathing towel
- 15 nudist sunbathing area
- 16 nudist (naturist)
- 17 screen (fence)
- 18 mixed sauna
- 19 wood panelling (Am. paneling)
- 20 tiered benches
- 21 sauna stove
- 22 stones
23 hygrometer
- 24 thermometer
- 25 towel
- 26 water tub for moistening the stones in the stove
- 27 birch rods (birches) for beating the skin
- 28 cooling room for cooling off (cooling down) after the sauna
- 29 lukewarm shower
- 30 cold bath
- 31 hot whirlpool (underwater massage bath)
- 32 step into the bath
- 33 massage bath
- 34 jet blower
- 35 hot whirlpool [diagram]
- 36 section of the bath
- 37 step
- 38 circular seat
- 39 water extractor
- 40 water jet pipe
- 41 air jet pipe

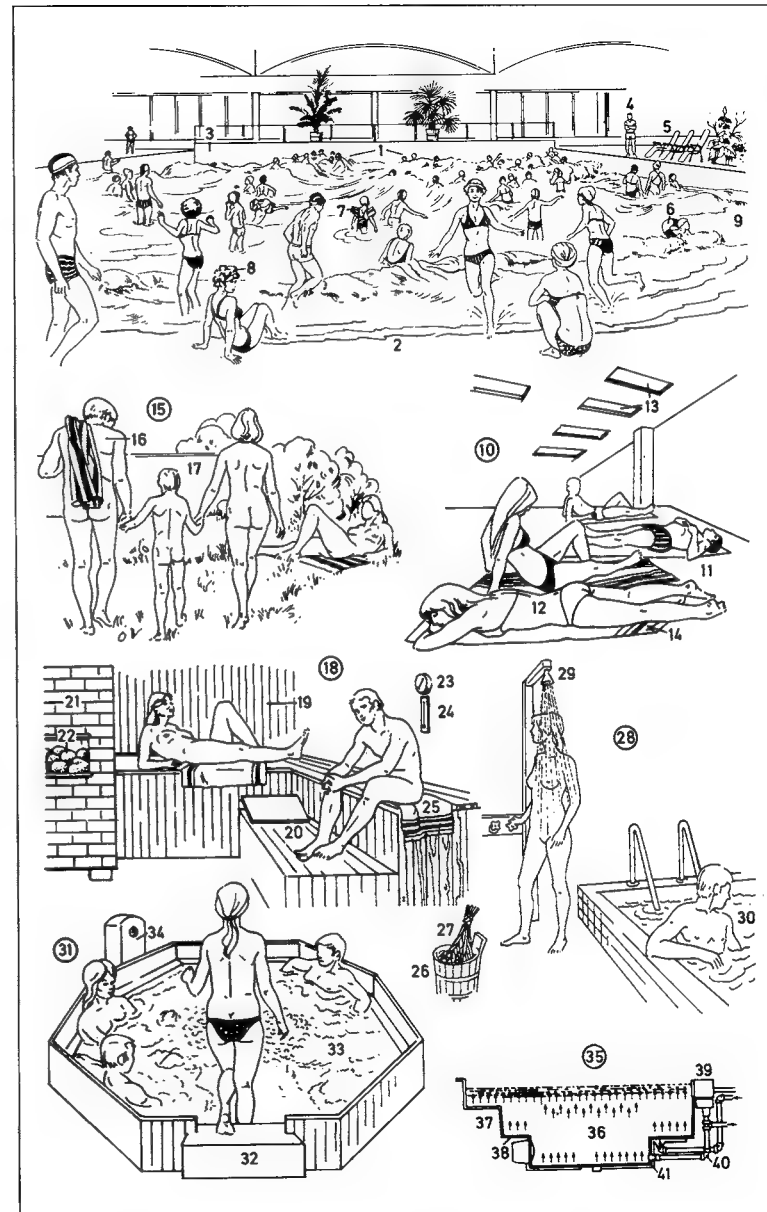

1-32 swimming pool, an open-air swimming pool

- 1 changing cubicle
- 2 shower (shower bath)
- 3 changing room
- 4 sunbathing area
- 5-10 diving boards** (diving apparatus)
- 5 diver (highboard diver)
- 6 diving platform
- 7 ten-metre (*Am.* ten-meter) platform
- 8 five-metre (*Am.* five-meter) platform
- 9 three-metre (*Am.* three-meter) springboard (diving board)
- 10 one-metre (*Am.* one-meter) springboard
- 11 diving pool
- 12 straight header
- 13 feet-first jump
- 14 tuck jump (hunch jump)
- 15 swimming pool attendant (pool attendant, swimming bath attendant)
- 16-20 swimming instruction**
- 16 swimming instructor (swimming teacher)
- 17 learner-swimmer
- 18 float; *sim.*: water wings
- 19 swimming belt (cork jacket)
- 20 land drill
- 21 non-swimmers' pool
- 22 footbath
- 23 swimmers' pool
- 24-32 freestyle relay race**
- 24 timekeeper (lane timekeeper)
- 25 placing judge
- 26 turning judge
- 27 starting block (starting place)
- 28 competitor touching the finishing line
- 29 starting dive (racing dive)
- 30 starter
- 31 swimming lane
- 32 rope with cork floats
- 33-39 swimming strokes**
- 33 breaststroke

- 34 butterfly stroke
- 35 dolphin butterfly stroke
- 36 side stroke
- 37 crawl stroke (crawl); *sim.*: trudgen stroke (trudgen, double overarm stroke)
- 38 diving (underwater swimming)
- 39 treading water
- 40-45 diving** (acrobatic diving, fancy diving, competitive diving, highboard diving)
- 40 standing take-off pike dive
- 41 one-half twist isander (reverse dive)
- 42 backward somersault (double backward somersault)
- 43 running take-off twist dive
- 44 screw dive
- 45 armstand dive (handstand dive)
- 46-50 water polo**
- 46 goal
- 47 goalkeeper
- 48 water polo ball
- 49 back
- 50 forward

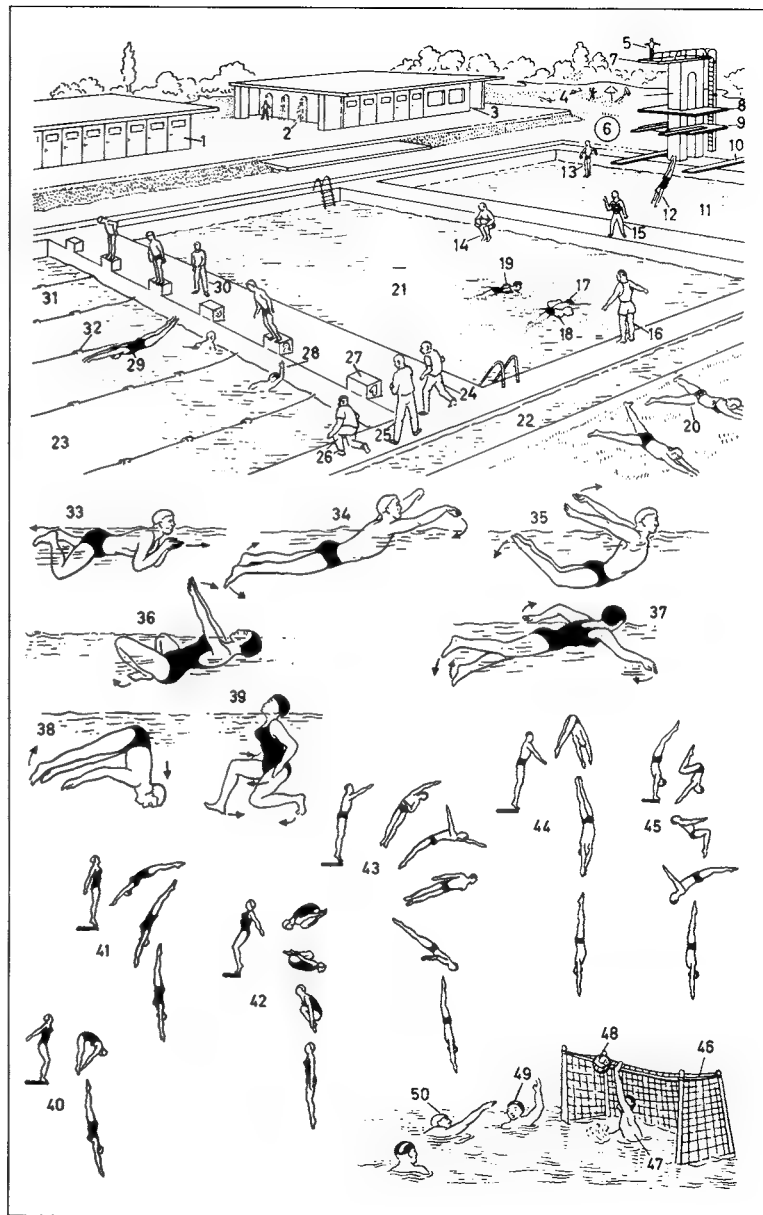

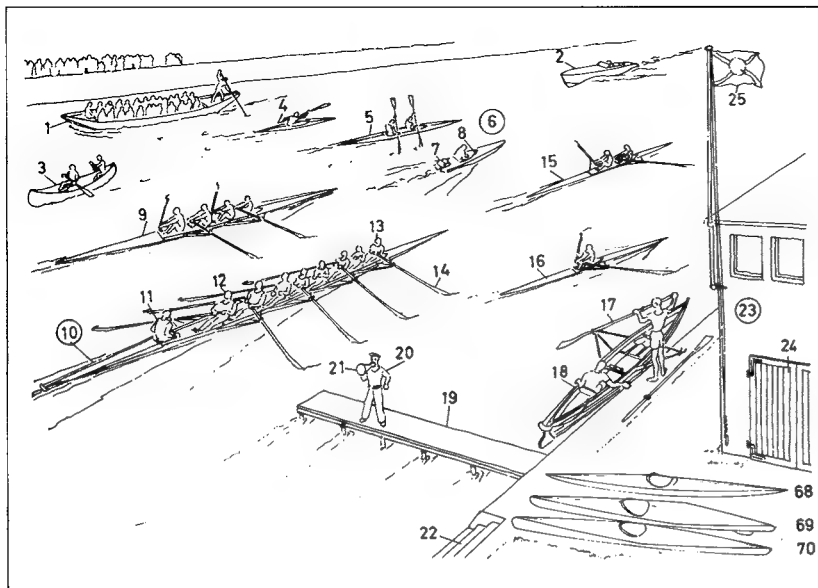

1-18 taking up positions for the regatta

1 punt, a pleasure boat

2 motorboat

3 Canadian canoe

4 kayak (Alaskan canoe, slalom canoe), a canoe

5 tandem kayak

6 outboard motorboat (outboard speedboat, outboard)

7 outboard motor (outboard)

8 cockpit

9-16 racing boats (sportsboats)

9-15 shells (rowing boats, *Am.* rowboats)

9 coxless four, a carvel-built boat

10 eight (eight-oared racing shell)

11 cox

12 stroke, an oarsman

13 bow ('number one')

14 oar

15 coxless pair

16 single sculler (single skuller, racing sculler, racing skuller, skiff)

17 scull (skull)

18 coxed single, a clinker-built single

19 jetty (landing stage)

20 rowing coach

21 megaphone

22 quayside steps

23 clubhouse (club)

24 boathouse

25 club's flag

26-33 four-oared gig, a touring boat

26 oar

27 cox's seat

28 thwart (seat)

29 rowlock (oarlock)

30 gunwale (gunnel)

31 rising

32 keel

33 skin (shell, outer skin) [clinker-built]

34 single-bladed paddle (paddle)

35-38 oar (scull, skull)

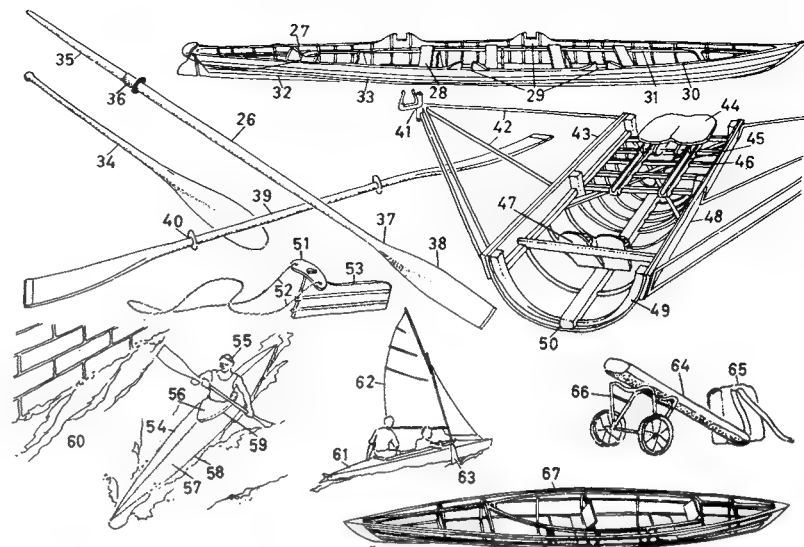

35 grip

36 leather sheath

37 shaft (neck)

38 blade

39 double-bladed paddle (double-ended paddle)

40 drip ring

41-50 sliding seat

41 rowlock (oarlock)

42 outrigger

43 saxboard

44 sliding seat

45 runner

46 strut

47 stretcher

48 skin (shell; outer skin)

49 frame (rib)

50 keelson (keelson)

51-53 rudder (steering rudder)

51 yoke

52 lines (steering lines)

53 blade (rudder blade, rudder)

54-66 folding boats (foldboats, canoes)

54 one-man kayak

55 canoeist

56 spraydeck

57 deck

58 rubber-covered canvas hull

59 cockpit coaming (coaming)

60 channel for rafts alongside weir

61 two-seater folding kayak, a touring kayak

62 sail of folding kayak

63 leeboard

64 bag for the rods

65 rucksack

66 boat trailer (boat carriage)

67 frame of folding kayak

68-70 kayaks

68 Eskimo kayak

69 wild-water racing kayak

70 touring kayak

1-9 windsurfing

- 1 windsurfer
- 2 sail
- 3 transparent window (window)
- 4 mast
- 5 surfboard
- 6 universal joint (movable bearing) for adjusting the angle of the mast and for steering
- 7 wishbone
- 8 retractable centreboard (*Am.* centerboard)
- 9 rudder

10-48 yacht (sailing boat, *Am.* sailboat)

- 10 foredeck
- 11 mast
- 12 trapeze
- 13 crosstrees (spreader)
- 14 hound
- 15 forestay
- 16 jib (Genoa jib)
- 17 jib downhaul
- 18 side stay (shroud)
- 19 lanyard (*also:* turnbuckle)
- 20 foot of the mast
- 21 kicking strap (vang)
- 22 jam cleat
- 23 foresheet (jib sheet)
- 24 centreboard (*Am.* centerboard) case
- 25 bitt
- 26 centreboard (*Am.* centerboard)
- 27 traveller (*Am.* traveler)
- 28 mainsheet
- 29 foresheet fairlead (jib fairlead)
- 30 toestraps (hiking straps)
- 31 tiller extension (hiking stick)
- 32 tiller
- 33 rudderhead (rudder stock)
- 34 rudder blade (rudder)
- 35 transom
- 36 drain plug
- 37 gooseneck
- 38 window
- 39 boom
- 40 foot

- 41 clew
- 42 luff (leading edge)
- 43 leech pocket (batten cleat, batten pocket)
- 44 batten
- 45 leech (trailing edge)
- 46 mainsail
- 47 headboard
- 48 racing flag (burgee)
- 49-65 yacht classes
- 49 Flying Dutchman
- 50 O-Joller
- 51 Finn dinghy (Finn)
- 52 pirate
- 53 12.00 m² sharpie
- 54 tempest
- 55 star
- 56 soling
- 57 dragon
- 58 5.5-metre (*Am.* 5.5-meter) class
- 59 6-metre (*Am.* 6-meter) R-class
- 60 30.00 m² cruising yacht (coastal cruiser)
- 61 30.00 m² dinghy cruiser
- 62 25.00 m² one-design keelboat
- 63 KR-class
- 64 catamaran
- 65 twin hull

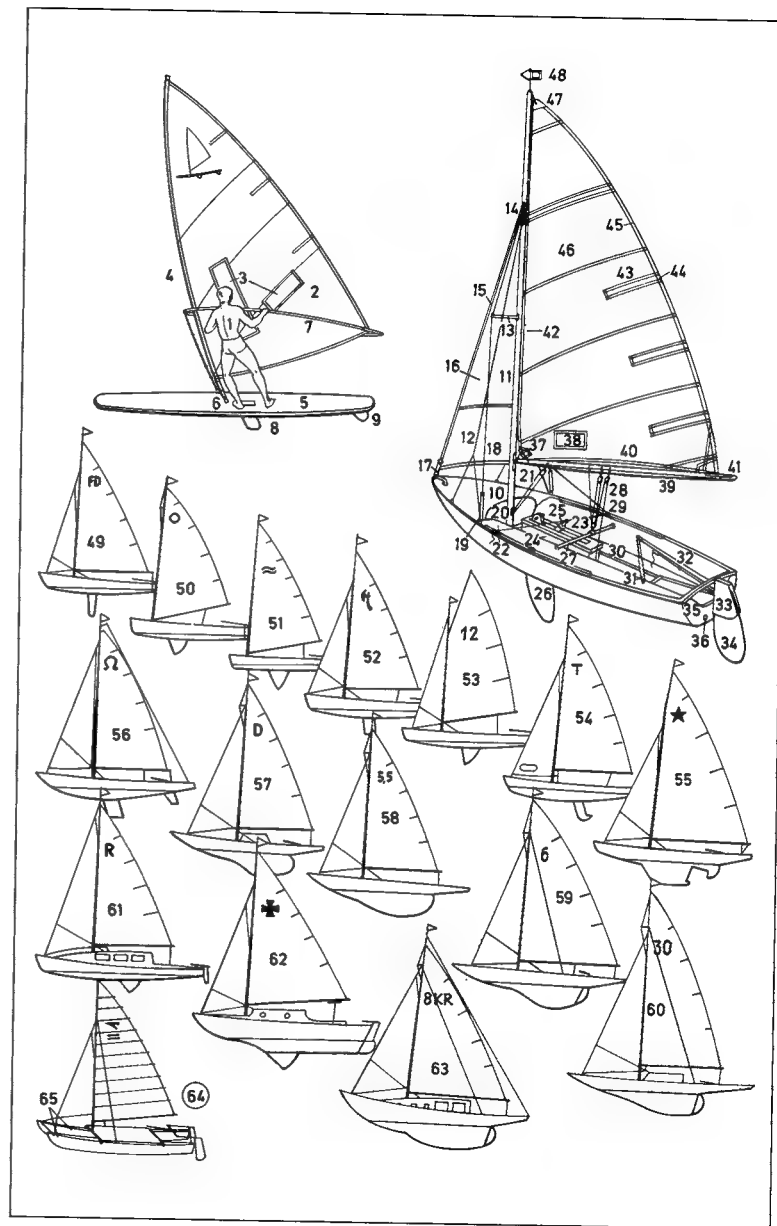

1-13 points of sailing and wind directions

- 1 sailing downwind (running)
- 2 mainsail
- 3 jib
- 4 sails set goose-winged
- 5 centre (*Am.* center) line
- 6 wind direction
- 7 yacht stopped head to wind
- 8 sail, shivering
- 9 luffing
- 10 sailing close-hauled
- 11 sailing with wind abeam
- 12 sailing with free wind
- 13 quartering wind (quarter wind)

14-24 regatta course

- 14 starting and finishing buoy
 - 15 committee boat
 - 16 triangular course (regatta course)
 - 17 buoy (mark) to be rounded
 - 18 buoy to be passed
 - 19 first leg
 - 20 second leg
 - 21 third leg
 - 22 windward leg
 - 23 downwind leg
 - 24 reaching leg
- 25-28 tacking**
- 25 tack
 - 26 gybing (jibing)
 - 27 going about
 - 28 loss of distance during the gybe (jibe)

29-41 types of yacht hull

- 29-34 cruiser keelboat
- 29 stern
- 30 spoon bow
- 31 waterline
- 32 keel (ballast keel)
- 33 ballast
- 34 rudder
- 35 racing keelboat
- 36 lead keel
- 37-41 keel-centreboard (*Am.* center-board) yawl
- 37 retractable rudder
- 38 cockpit

39 cabin superstructure (cabin)

40 straight stem

41 retractable centreboard (*Am.* centerboard)**42-49 types of yacht stern**

42 yacht stern

43 square stern

44 canoe stern

45 cruiser stern

46 name plate

47 deadwood

48 transom stern

49 transom

50-57 timber planking

50-52 clinker planking (clench planking)

50 outside strake

51 frame (rib)

52 clenched nail (riveted nail)

53 carvel planking

54 ribband-carvel construction

55 ribband, a stringer

56 diagonal carvel planking

57 inner planking

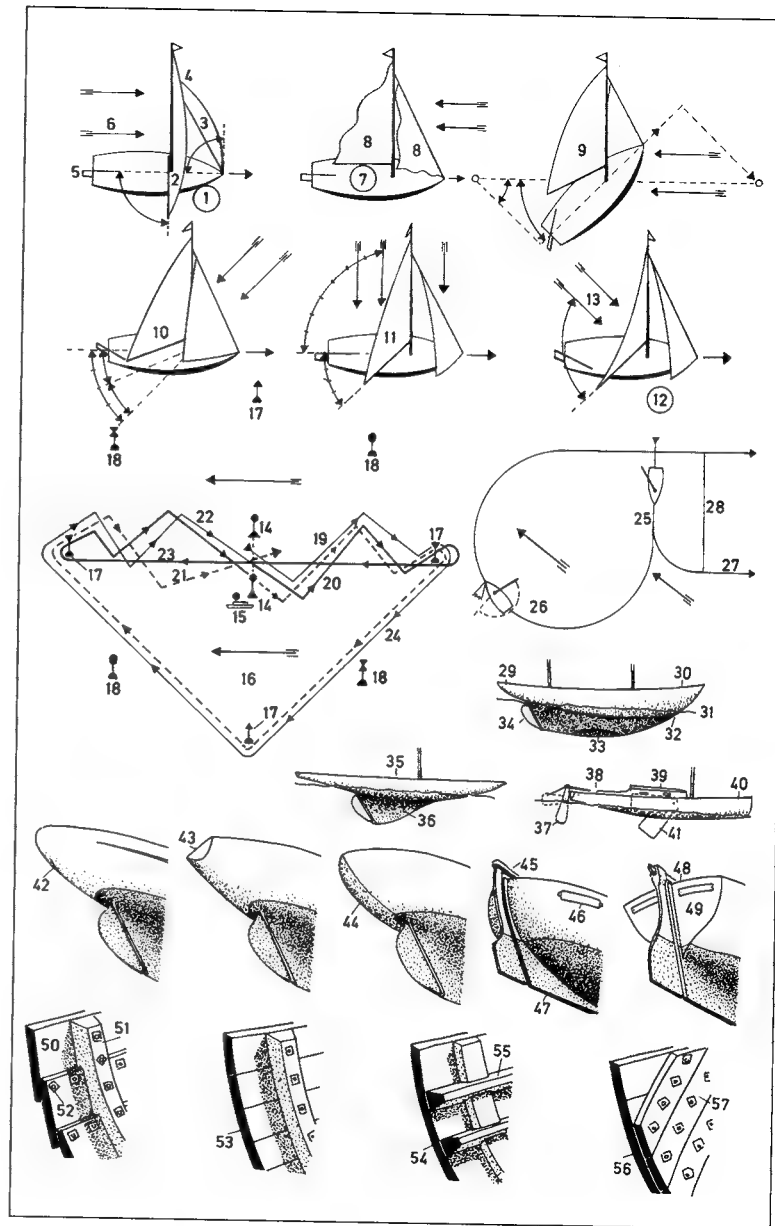

- 1-5 motorboats (powerboats, sportsboats)
 1 inflatable sportsboat with outboard motor (outboard inflatable)
 2 Z-drive motorboat (outdrive motorboat)
 3 cabin cruiser
 4 motor cruiser
 5 30-metre (*Am.* 30-meter) ocean-going cruiser
 6 association flag
 7 name of craft (*or:* registration number)
 8 club membership and port of registry (*Am.* home port)
 9 association flag on the starboard crosstrees
 10-14 navigation lights of sportsboats in coastal and inshore waters
 10 white top light
 11 green starboard sidelight
 12 red port sidelight
 13 green and red bow light (combined lantern)
 14 white stern light
 15-18 anchors
 15 stocked anchor (Admiralty anchor), a bower anchor
 16-18 lightweight anchor
 16 CQR anchor (plough, *Am.* plow, anchor)
 17 stockless anchor (patent anchor)
 18 Danforth anchor
 19 life raft
 20 life jacket
 21-44 powerboat racing
 21 catamaran with outboard motor
 22 hydroplane
 23 racing outboard motor
 24 tiller
 25 fuel pipe
 26 transom
 27 buoyancy tube
 28 start and finish
 29 start
 30 starting and finishing line
 31 buoy to be rounded
 32-37 displacement boats
 32-34 round-bilge boat
 32 view of hull bottom
 33 section of fore ship
 34 section of aft ship
 35-37 V-bottom boat (vee-bottom boat)
 35 view of hull bottom
 36 section of fore ship
 37 section of aft ship
 38-44 planing boats (surface skimmers, skimmers)
 38-41 stepped hydroplane (stepped skimmer)
 38 side view
 39 view of hull bottom
 40 section of fore ship
 41 section of aft ship
 42 three-point hydroplane
 43 fin
 44 float
 45-62 water skiing
 45 water skier
 46 deep-water start
 47 tow line (towing line)
 48 handle
 49-55 water-ski signalling (code of hand signals from skier to boat driver)
 49 signal for 'faster'
 50 signal for 'slower' ('slow down')
 51 signal for 'speed OK'
 52 signal for 'turn'
 53 signal for 'stop'
 54 signal for 'cut motor'
 55 signal for 'return to jetty' ('back to dock')
 56-62 types of water ski
 56 trick ski (figure ski), a monoski
 57, 58 rubber binding
 57 front foot binding
 58 heel flap
 59 strap support for second foot
 60 slalom ski
 61 skeg (fixed fin, fin)
 62 jump ski
 63 hovercraft (air-cushion vehicle)
 64 propeller
 65 rudder
 66 skirt enclosing air cushion

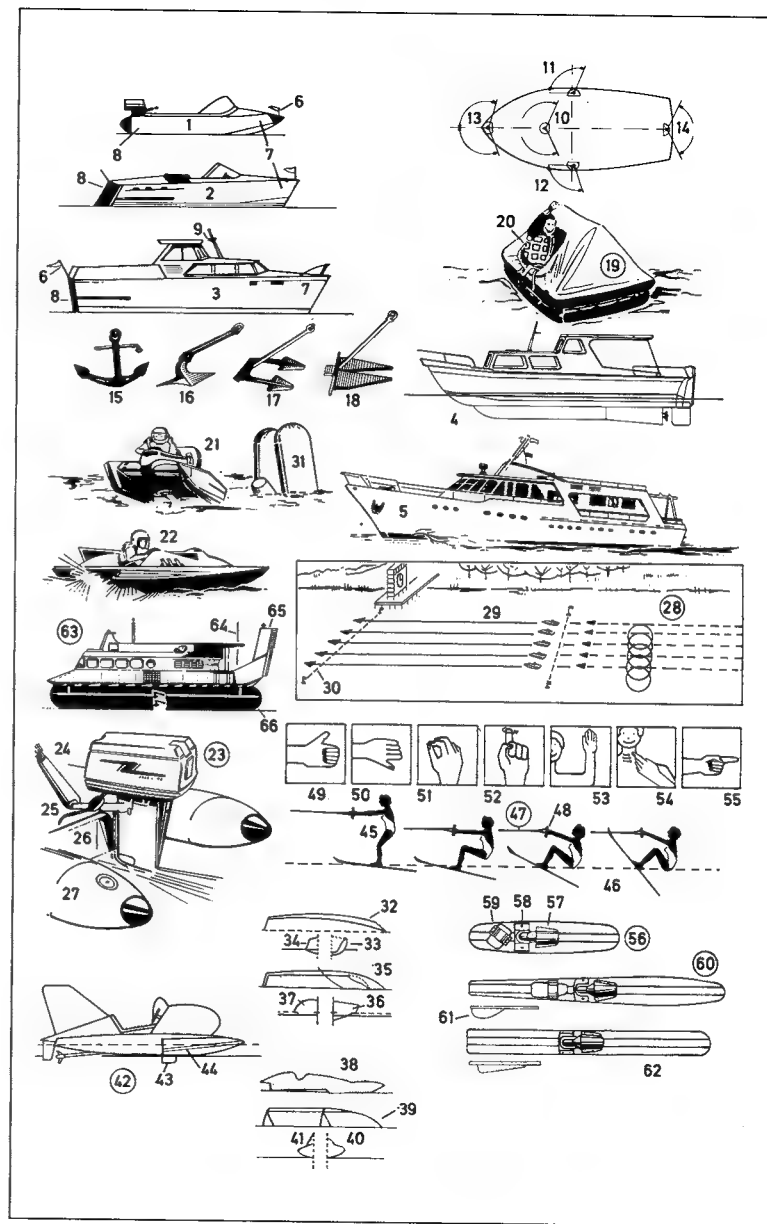

- 1 aeroplane (*Am.* airplane) tow launch (aerotowing)
 2 tug (towing plane)
 3 towed glider (towed sailplane)
 4 tow rope
 5 winched launch
 6 motor winch
 7 cable parachute
 8 motorized glider (powered glider)
 9 high-performance glider (high-performance sailplane)
 10 T-tail (T-tail unit)
 11 wind sock (wind cone)
 12 control tower (tower)
 13 glider field
 14 hangar
 15 runway for aeroplanes (*Am.* air-planes)
 16 wave soaring
 17 lee waves (waves, wave system)
 18 rotor
 19 lenticular clouds (lenticulars)
 20 thermal soaring
 21 thermal
 22 cumulus cloud (heap cloud, cumulus, woolpack cloud)
 23 storm-front soaring
 24 storm front
 25 frontal upcurrent
 26 cumulonimbus cloud (cumulonimbus)
 27 slope soaring
 28 hill upcurrent (orographic lift)
 29 multispar wing
 30 main spar, a box spar
 31 connector fitting
 32 anchor rib
 33 diagonal spar
 34 leading edge
 35 main rib
 36 nose rib (false rib)
 37 trailing edge
 38 brake flap (spoiler)
 39 torsional clamp
 40 covering (skin)
 41 aileron
 42 wing tip
 43 hang gliding
 44 hang glider
 45 hang glider pilot
 46 control frame

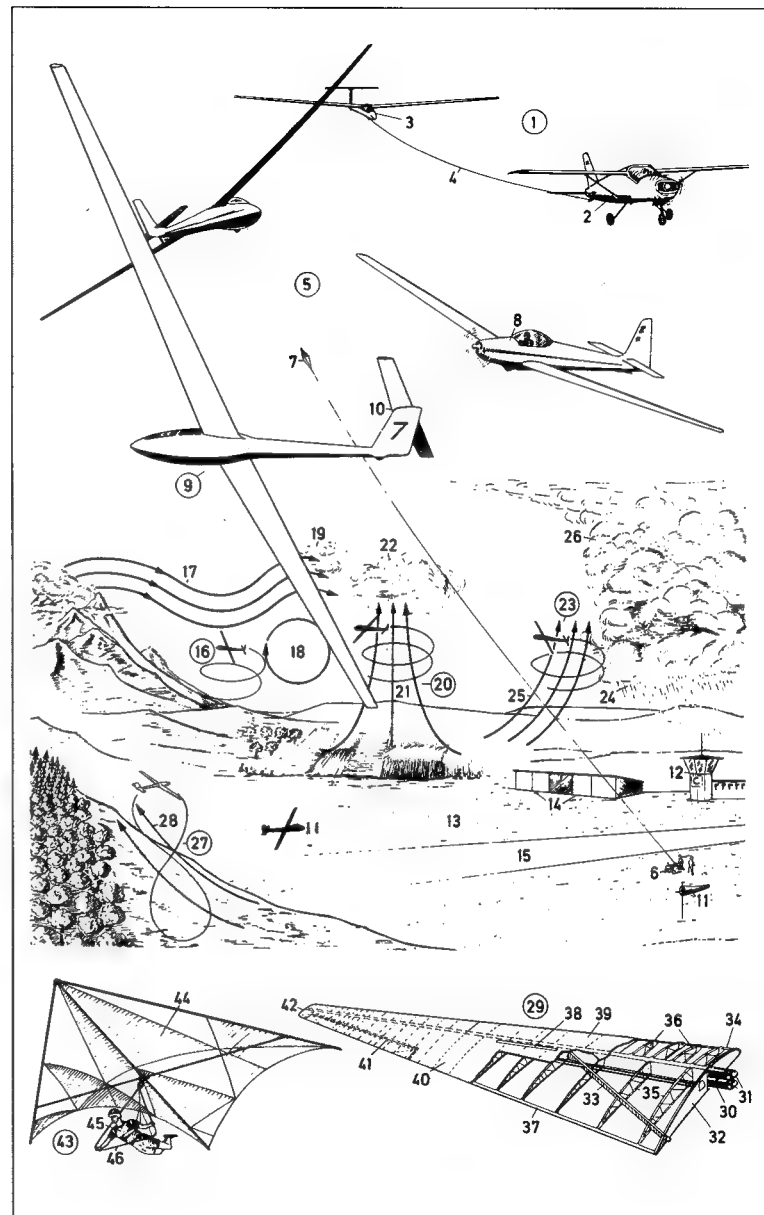

- 1-9 **aerobatics** (aerobic manoeuvres, *Am.* maneuvers)
- 1 loop
 - 2 horizontal eight
 - 3 rolling circle
 - 4 stall turn (hammer head)
 - 5 tail slide (whip stall)
 - 6 vertical flick spin
 - 7 spin
 - 8 horizontal slow roll
 - 9 inverted flight (negative flight)
- 10 **cockpit**
- 11 instrument panel
 - 12 compass
 - 13 radio and navigation equipment
 - 14 control column (control stick)
 - 15 throttle lever (throttle control)
 - 16 mixture control
 - 17 radio equipment
- 18 **two-seater plane for racing and aerobatics**
- 19 cabin
 - 20 antenna
 - 21 vertical stabilizer (vertical fin, tail fin)
 - 22 rudder
 - 23 tailplane (horizontal stabilizer)
 - 24 elevator
 - 25 trim tab (trimming tab)
 - 26 fuselage (body)
 - 27 wing
 - 28 aileron
 - 29 landing flap
 - 30 trim tab (trimming tab)
 - 31 navigation light (position light) [red]
 - 32 landing light
 - 33 main undercarriage unit (main landing gear unit)
 - 34 nose wheel
 - 35 engine
 - 36 propeller (airscrew)
- 37-62 **parachuting** (sport parachuting)
- 37 parachute
 - 38 canopy
 - 39 pilot chute
 - 40 suspension lines
 - 41 steering line
 - 42 riser
 - 43 harness
 - 44 pack
 - 45 system of slots of the sports parachute
 - 46 turn slots
 - 47 apex
 - 48 skirt
 - 49 stabilizing panel
 - 50, 51 style jump

- 50 back loop
 - 51 spiral
 - 52-54 ground signals
 - 52 signal for 'permission to jump' ('conditions are safe') (target cross)
 - 53 signal for 'parachuting suspended-repeat flight'
 - 54 signal for 'parachuting suspended-aircraft must land'
 - 55 accuracy jump
 - 56 target cross
 - 57 inner circle [radius 25 m]
 - 58 middle circle [radius 50 m]
 - 59 outer circle [radius 100 m]
 - 60-62 free-fall positions
 - 60 full spread position
 - 61 frog position
 - 62 T position
- 63-84 **ballooning**
- 63 gas balloon
 - 64 gondola (balloon basket)
 - 65 ballast (sandbags)
 - 66 mooring line
 - 67 hoop
 - 68 flight instruments (instruments)
 - 69 trail rope
 - 70 mouth (neck)
 - 71 neck line
 - 72 emergency rip panel
 - 73 emergency ripping line
 - 74 network (net)
 - 75 rip panel
 - 76 ripping line
 - 77 valve
 - 78 valve line
 - 79 hot-air balloon
 - 80 burner platform
 - 81 mouth
 - 82 vent
 - 83 rip panel
 - 84 balloon take-off
- 85-91 **flying model aeroplanes** (*Am.* airplanes)
- 85 radio-controlled model flight
 - 86 remote-controlled free flight model
 - 87 remote control radio
 - 88 antenna (transmitting antenna)
 - 89 control line model
 - 90 mono-line control system
 - 91 flying kennel, a K9-class model

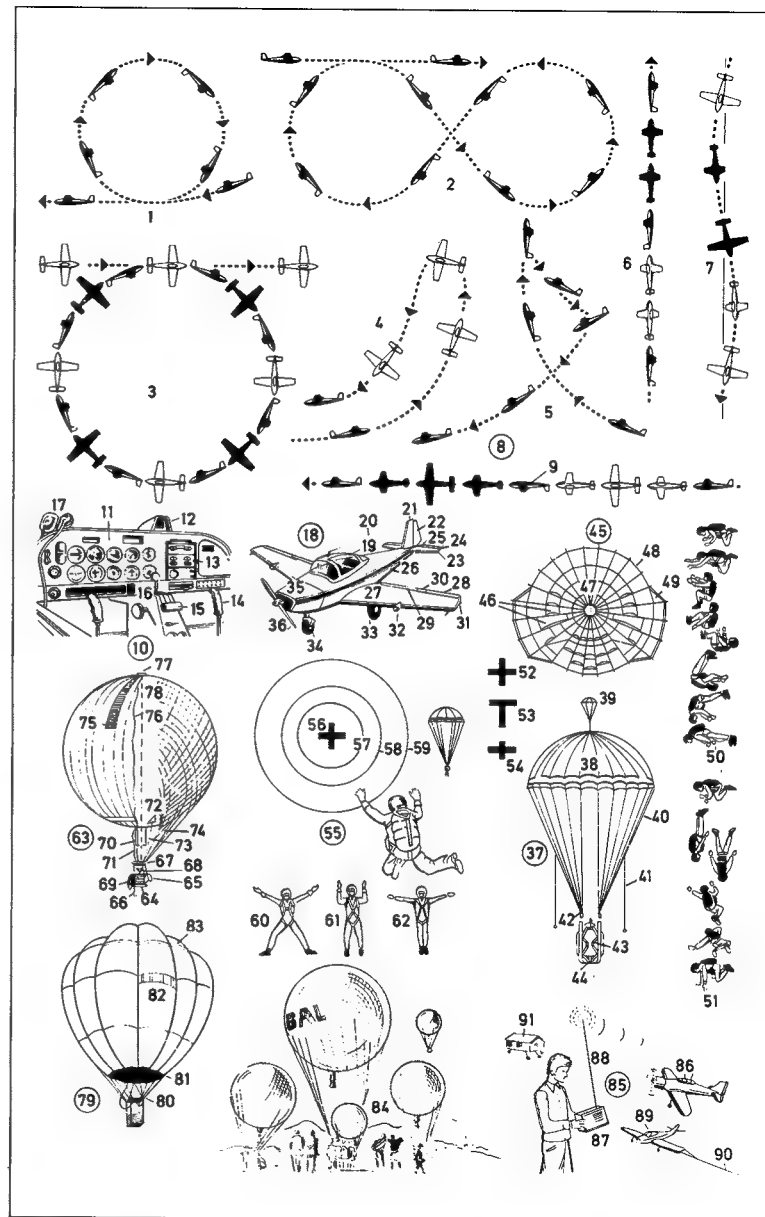

1-7 dressage
 1 arena (dressage arena)
 2 rail
 3 school horse
 4 dark coat (black coat)
 5 white breeches
 6 top hat
 7 gait (*also*: school figure)
 8-14 show jumping
 8 obstacle (fence), an almost-fixed obstacle; *sim.*: gate, gate and rails, palisade, oxer, mound, wall
 9 jumper
 10 jumping saddle
 11 girth
 12 snaffle
 13 red coat (hunting pink, pink; *also*: dark coat)
 14 hunting cap (riding cap)
 15 bandage
 16-19 three-day event
 16 endurance competition
 17 cross-country
 18 helmet (*also*: hard hat, hard hunting cap)
 19 course markings
 20-22 steeplechase
 20 water jump, a fixed obstacle
 21 jump
 22 riding switch
 23-40 harness racing (harness horse racing)
 23 harness racing track (track)
 24 sulky
 25 spoke wheel (spoked wheel) with plastic wheel disc (disk)
 26 driver in trotting silks
 27 rein
 28 trotter
 29 piebald horse
 30 shadow roll
 31 elbow boot
 32 rubber boot
 33 number
 34 glass-covered grandstand with totalizator windows (*tote windows*) inside

35 totalizator (*tote*)
 36 number
 37 odds (price, starting price, price offered)
 38 winners' table
 39 winner's price
 40 time indicator
 41-49 hunt, a drag hunt; *sim.*: fox hunt, paper chase (paper hunt, hare-and-hounds)
 41 field
 42 hunting pink
 43 whipper-in (whip)
 44 hunting horn
 45 Master (Master of foxhounds, MFH)
 46 pack of hounds (pack)
 47 staghound
 48 drag
 49 scented trail (artificial scent)
 50 horse racing (racing)
 51 field (racehorses)
 52 favourite (*Am.* favorite)
 53 outsider

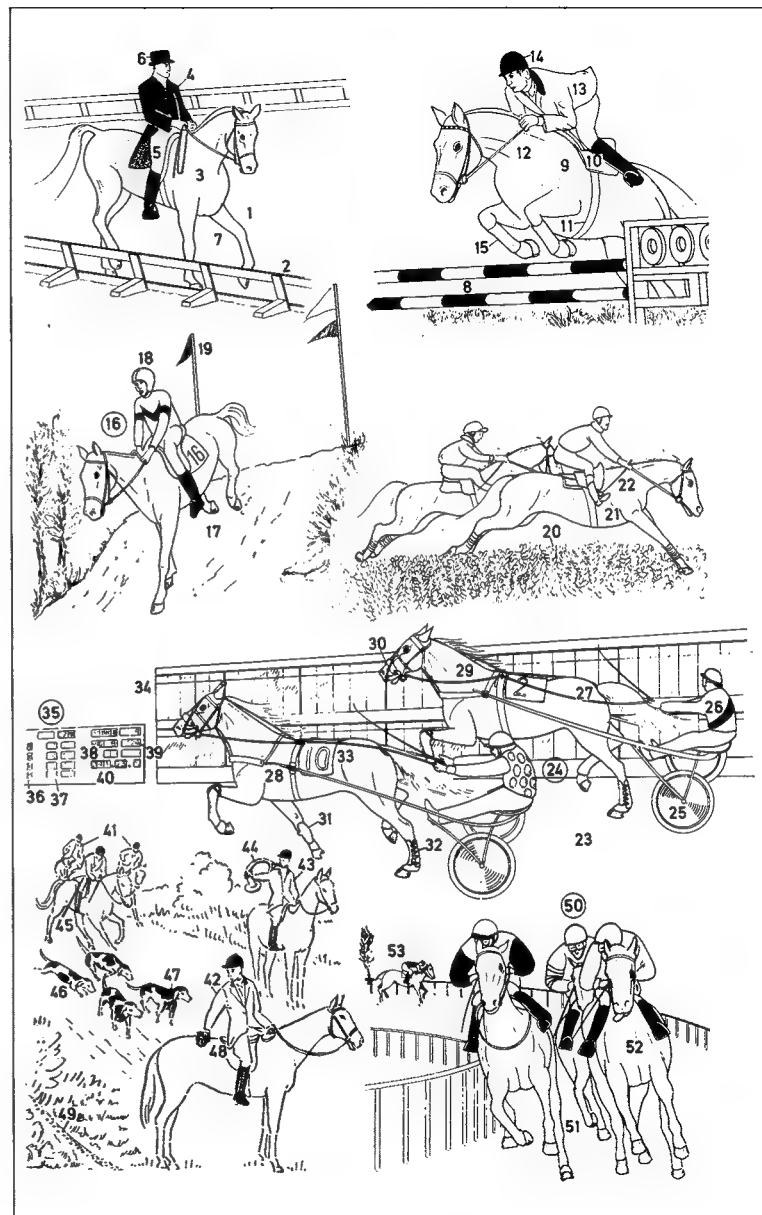

1-23 cycle racing

- 1 cycling track (cycle track); *here:* indoor track
 2-7 six-day race
 2 six-day racer, a track racer (track rider) on the track
 3 crash hat
 4 stewards
 5 judge
 6 lap scorer
 7 rider's box (racer's box)
 8-10 road race
 8 road racer, a racing cyclist
 9 racing jersey
 10 water bottle

11-15 motor-paced racing (long-distance racing)

- 11 pacer, a motorcyclist
 12 pacer's motorcycle
 13 roller, a safety device
 14 stayer (motor-paced track rider)
 15 motor-paced cycle, a racing cycle
 16 racing cycle (racing bicycle) for road racing (road race bicycle)
 17 racing saddle, an unsprung saddle
 18 racing handlebars (racing handlebar)
 19 tubular tyre (*Am.* tire) (racing tyre)
 20 chain
 21 toe clip (racing toe clip)
 22 strap
 23 spare tubular tyre (*Am.* tire)

24-38 motorsports

- 24-28 motorcycle racing; *disciplines:*
 grasstrack racing, road racing, sand track racing, cement track racing, speedway [on ash or shale tracks], mountain racing, ice racing (ice speedway), scramble racing, trial, moto cross
 24 sand track
 25 racing motorcyclist (rider)
 26 leather overalls (leathers)
 27 racing motorcycle, a solo machine
 28 number (number plate)
 29 sidecar combination on the bend

- 30 sidecar
 31 streamlined racing motorcycle [500 cc.]
 32 gymkhana, a competition of skill; *here:* motorcyclist performing a jump
 33 cross-country race, a test in performance
 34-38 racing cars
 34 Formula One racing car (a mono posto)
 35 rear spoiler (aerofoil, *Am.* airfoil)
 36 Formula Two racing car
 37 Super-Vee racing car
 38 prototype, a racing car

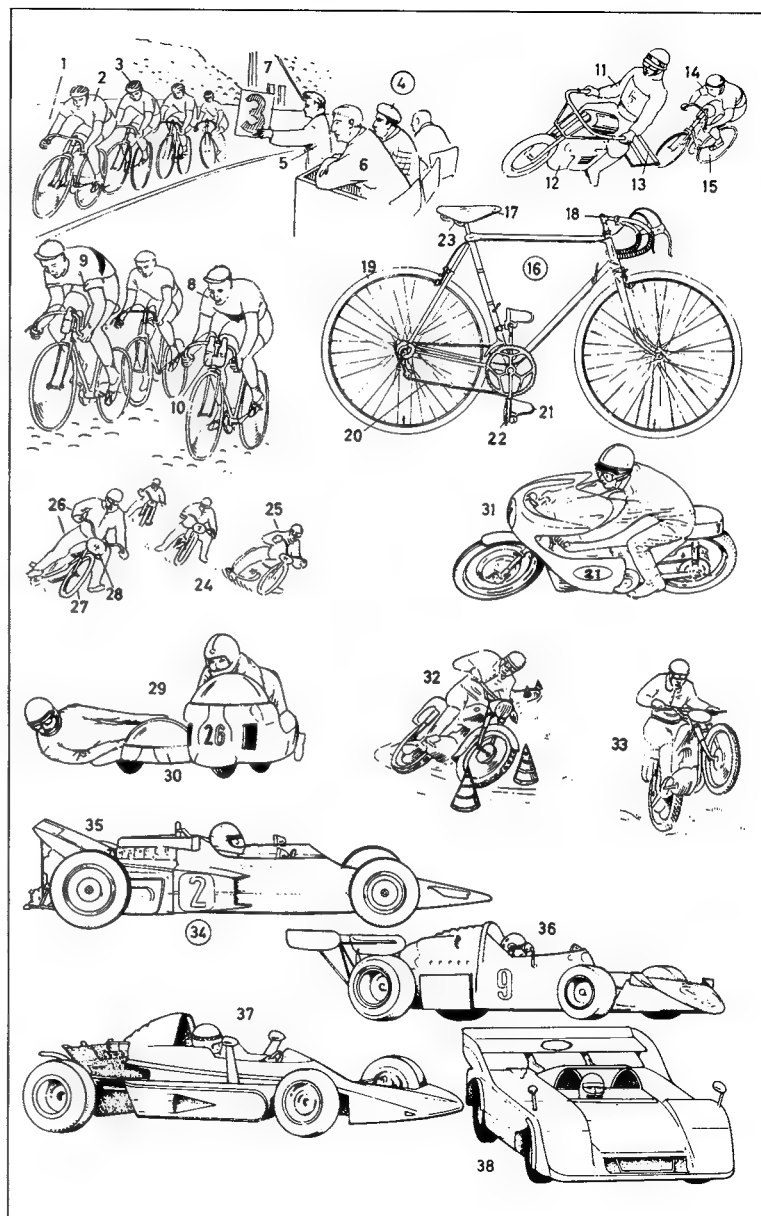

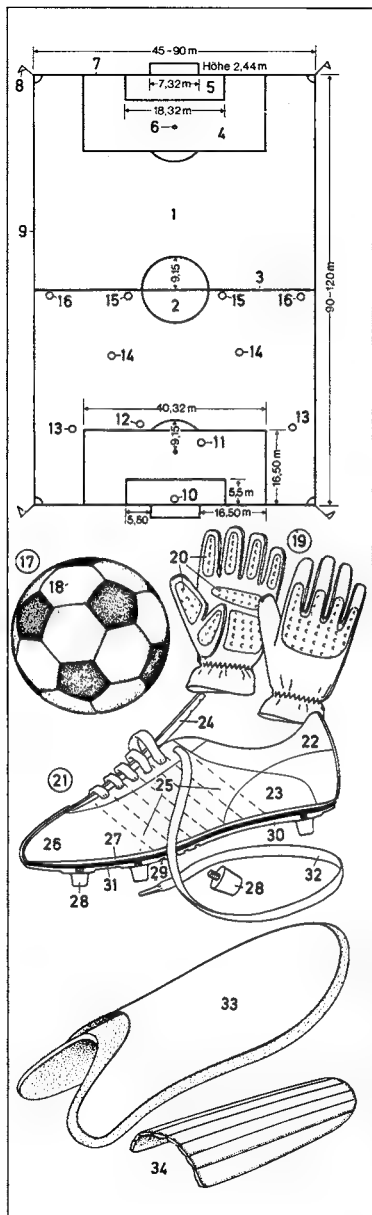

- 1-16 football pitch
- 1 field (park)
- 2 centre (*Am.* center) circle
- 3 half-way line
- 4 penalty area
- 5 goal area
- 6 penalty spot
- 7 goal line (by-line)
- 8 corner flag
- 9 touch line
- 10 goalkeeper
- 11 sweeper (*libero*)
- 12 inside defender
- 13 outside defender
- 14 midfield players
- 15 inside forward (striker)
- 16 outside forward (winger)
- 17 football
- 18 valve
- 19 goalkeeper's gloves
- 20 foam rubber padding
- 21 football boot
- 22 leather lining
- 23 counter
- 24 foam rubber tongue
- 25 bands
- 26 shaft
- 27 insole
- 28 screw-in stud
- 29 groove
- 30 nylon sole
- 31 inner sole
- 32 lace (bootlace)
- 33 football pad with ankle guard
- 34 shin guard
- 35 goal
- 36 crossbar
- 37 post (goalpost)
- 38 goal kick
- 39 save with the fists
- 40 penalty (penalty kick)
- 41 corner (corner kick)
- 42 offside
- 43 free kick
- 44 wall
- 45 bicycle kick (overhead bicycle kick)

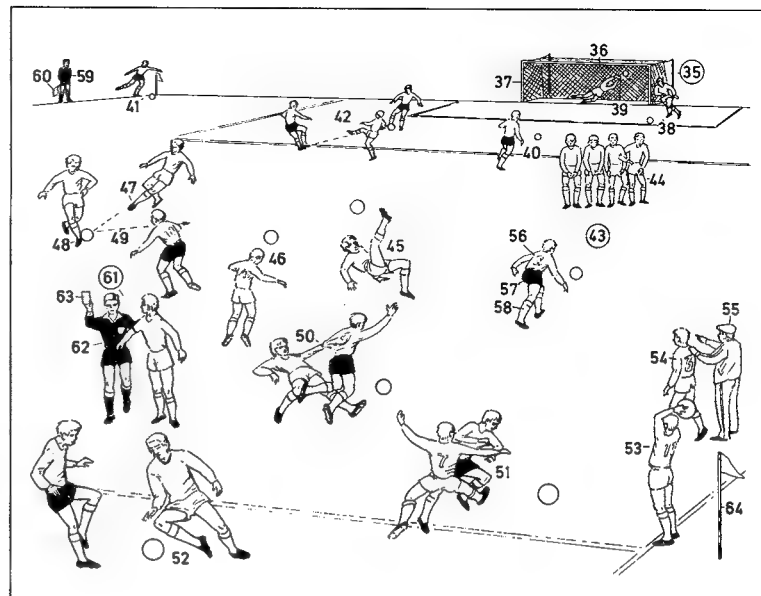

- 46 header
- 47 pass (passing the ball)
- 48 receiving the ball (taking a pass)
- 49 short pass (one-two)
- 50 foul (infringement)
- 51 obstruction
- 52 dribble
- 53 throw-in
- 54 substitute
- 55 coach
- 56 shirt (jersey)
- 57 shorts
- 58 sock (football sock)
- 59 linesman
- 60 linesman's flag
- 61 sending-off
- 62 referee
- 63 red card; *also*: yellow card
- 64 centre (*Am.* center) flag

- 1 handball (indoor handball)
 2 handball player, a field player
 3 attacker, making a jump throw
 4 defender
 5 penalty line
 6 hockey
 7 goal
 8 goalkeeper
 9 pad (shin pad, knee pad)
 10 kicker
 11 face guard
 12 glove
 13 hockey stick
 14 hockey ball
 15 hockey player
 16 striking circle
 17 sideline
 18 corner
 19 rugby (rugby football)
 20 scrum (scrummage)
 21 rugby ball
 22 American football (Am. football)
 23 player (football player) carrying the ball
 24 helmet
 25 face guard
 26 padded jersey
 27 ball (pigskin)
 28 basketball
 29 basketball player shooting
 30 backboard
 31 backboard support
 32 basket
 33 basket ring
 34 target rectangle
 35 basketball player shooting
 36 end line
 37 restricted area
 38 free-throw line
 39 substitute
 40-69 baseball
 40-58 field (park)
 40 spectator barrier
 41 outfielder
 42 short stop
 43 second base
 44 baseman
 45 runner
 46 first base
 47 third base
 48 foul line (base line)
 49 pitcher's mound
 50 pitcher
 51 batter's position
 52 batter
 53 home base (home plate)
 54 catcher
 55 umpire
 56 coach's box
 57 coach
 58 batting order
 59, 60 baseball gloves (baseball mitts)
 59 fielder's glove (fielder's mitt)
 60 catcher's glove (catcher's mitt)
 61 baseball
 62 bat
 63 batter at bat
 64 catcher
 65 umpire
 66 runner
 67 base plate
 68 pitcher
 69 pitcher's mound
 70-76 cricket
 70 wicket with bails
 71 bowling crease
 72 popping crease
 73 wicket keeper of the fielding side
 74 batsman
 75 bat (cricket bat)
 76 fielder (bowler)
 77-82 croquet
 77 winning peg
 78 hoop
 79 corner peg
 80 croquet player
 81 croquet mallet
 82 croquet ball

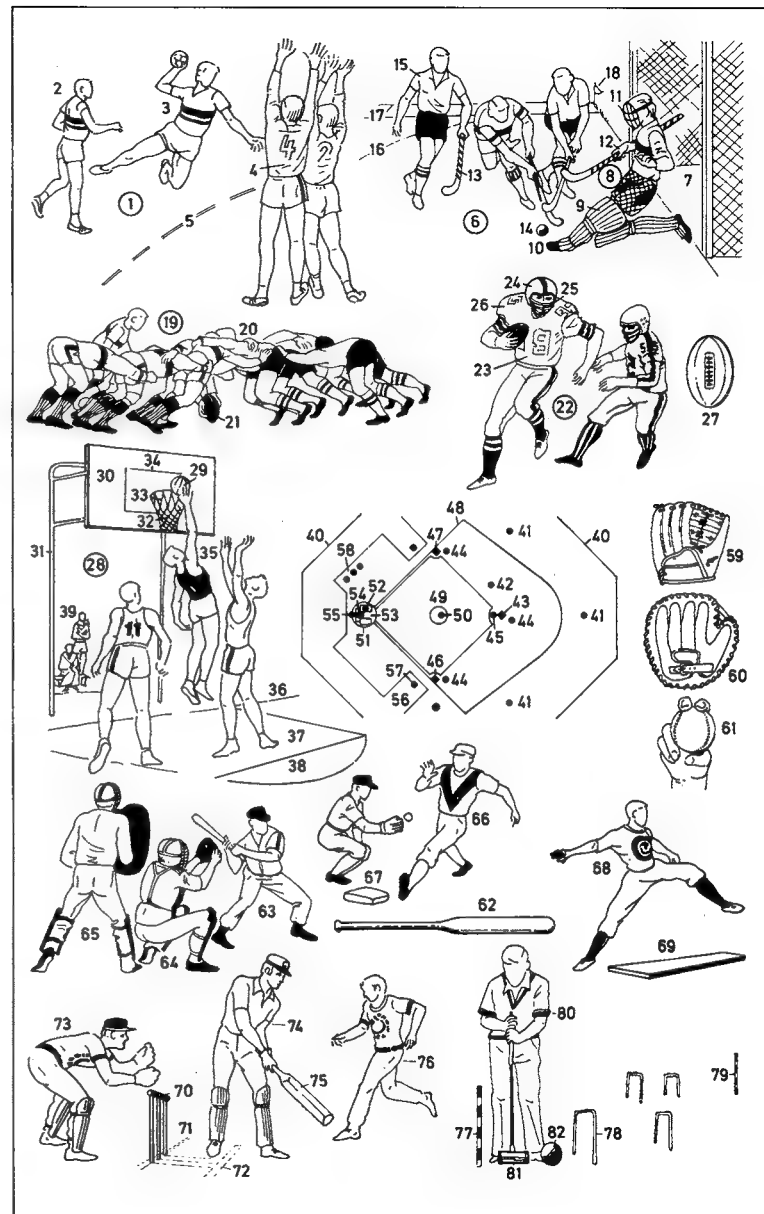

1-42 tennis

- 1 tennis court
2-3 doubles sideline (sideline for doubles matches); *kinds of doubles*: men's doubles, women's doubles, mixed doubles
3-10 base line
4-5 singles sideline (sideline for singles matches); *kinds of singles*: men's singles, women's singles
6-7 service line
8-9 centre (*Am.* center) line
11 centre (*Am.* center) mark
12 service court
13 net (tennis net)
14 net strap
15 net post
16 tennis player
17 smash
18 opponent
19 umpire
20 umpire's chair
21 umpire's microphone
22 ball boy
23 net-cord judge
24 foot-fault judge
25 centre (*Am.* center) line judge
26 base line judge
27 service line judge
28 tennis ball
29 tennis racket (tennis racquet, racket, racquet)
30 racket handle (racquet handle)
31 strings (striking surface)
32 press (racket press, racquet press)
33 tightening screw
34 scoreboard
35 results of sets
36 player's name
37 number of sets
38 state of play
39 backhand stroke
40 forehand stroke
41 volley (forehand volley at normal height)
42 service
43, 44 badminton
43 badminton racket (badminton racquet)
44 shuttle (shuttlecock)
45-55 table tennis
45 table tennis racket (racquet) (table tennis bat)
46 racket (racquet) handle (bat handle)
47 blade covering
48 table tennis ball

- 49 table tennis players; *here*: mixed doubles
50 receiver
51 server
52 table tennis table
53 table tennis net
54 centre (*Am.* center) line
55 sideline
56-71 volleyball
56, 57 correct placing of the hands
58 volleyball
59 serving the volleyball
60 blocker
61 service area
62 server
63 front-line player
64 attack area
65 attack line
66 defence (*Am.* defense) area
67 referee
68 umpire
69 linesman
70 scoreboard
71 scorer
72-78 faustball
72 base line
73 tape
74 faustball
75 forward
76 centre (*Am.* center)
77 back
78 hammer blow
79-93 golf
79-82 course (holes)
79 teeing ground
80 rough
81 bunker (*Am.* sand trap)
82 green (putting green)
83 golfer, driving
84 follow-through
85 golf trolley
86 putting (holing out)
87 hole
88 pin (flagstick)
89 golf ball
90 tee
91 wood, a driver; *sim.*: brassie (brassy, brassey)
92 iron
93 putter

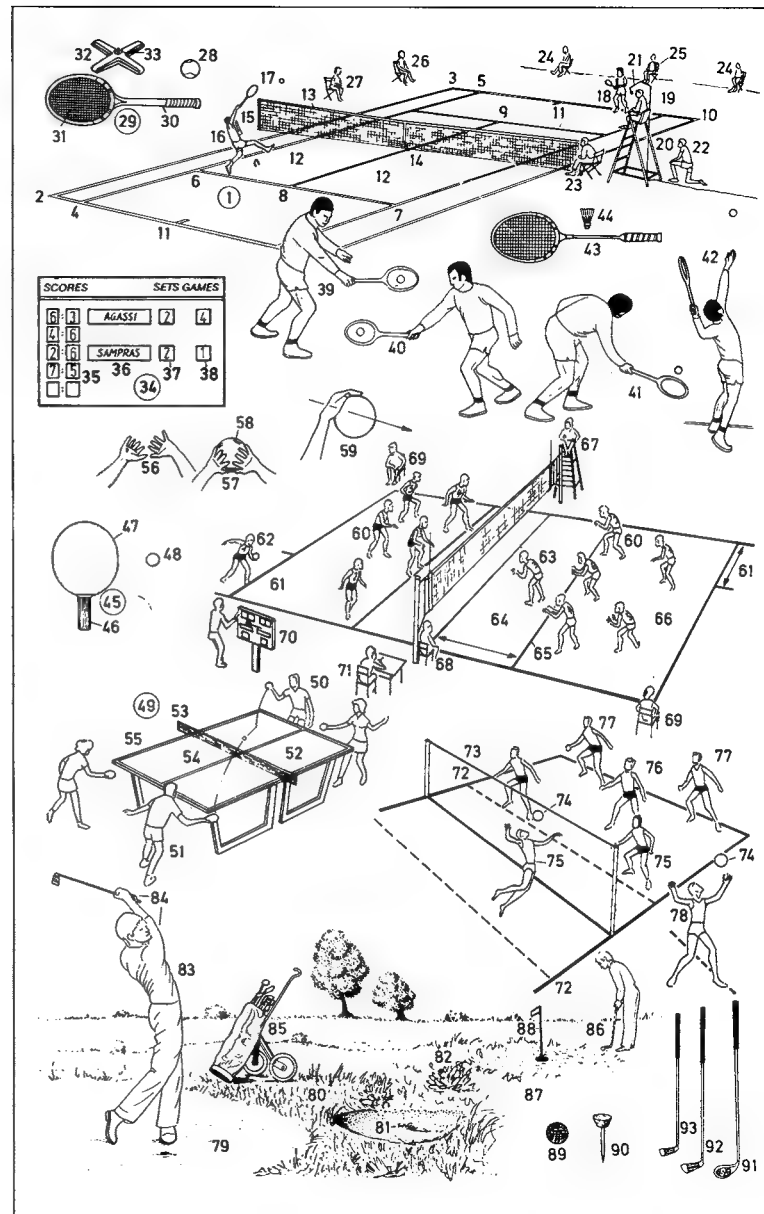

294 Fencing

- 1-33 fencing (modern fencing)
- 1-18 foil
- 1 fencing master (fencing instructor)
- 2 piste
- 3 on guard line
- 4 centre (*Am.* center) line
- 5, 6 fencers (foil fencers, foilsmen, foilists) in a bout
- 5 attacker (attacking fencer) in lunging position (lunging)
- 6 defender (defending fencer), parrying
- 7 straight thrust, a fencing movement
- 8 parry of the tierce
- 9 line of fencing
- 10 the three fencing measures (short, medium, and long measure)
- 11 foil, a thrust weapon
- 12 fencing glove
- 13 fencing mask (foil mask)
- 14 neck flap (neck guard) on the fencing mask
- 15 metallic jacket
- 16 fencing jacket
- 17 heelless fencing shoes
- 18 first position for fencer's salute (initial position, on guard position)
- 19-24 sabre (*Am.* saber) fencing
- 19 sabreurs (sabre fencers, *Am.* saber fencers)
- 20 (light) sabre (*Am.* saber)
- 21 sabre (*Am.* saber) glove (sabre gauntlet)
- 22 sabre (*Am.* saber) mask
- 23 cut at head
- 24 parry of the fifth (quinte)
- 25-33 épée, with electrical scoring equipment
- 25 épéiste
- 26 electric épée; *also:* electric foil
- 27 épée point
- 28 scoring lights
- 29 spring-loaded wire spool
- 30 indicator light
- 31 wire

- 32 electronic scoring equipment
- 33 on guard position
- 34-45 fencing weapons
- 34 light sabre (*Am.* saber), a cut and thrust weapon
- 35 guard
- 36 épée, a thrust weapon
- 37 French foil, a thrust weapon
- 38 guard (coquille)
- 39 Italian foil
- 40 foil pommel
- 41 handle
- 42 cross piece (quillons)
- 43 guard (coquille)
- 44 blade
- 45 button
- 46 engagements
- 47 quarte (carte) engagement
- 48 tierce engagement (*also:* sixte engagement)
- 49 circling engagement
- 50 seconde engagement (*also:* octave engagement)
- 51-53 target areas
- 51 the whole body in épée fencing (men)
- 52 head and upper body down to the groin in sabre (*Am.* saber) fencing (men)
- 53 trunk from the neck to the groin in foil fencing (ladies and men)

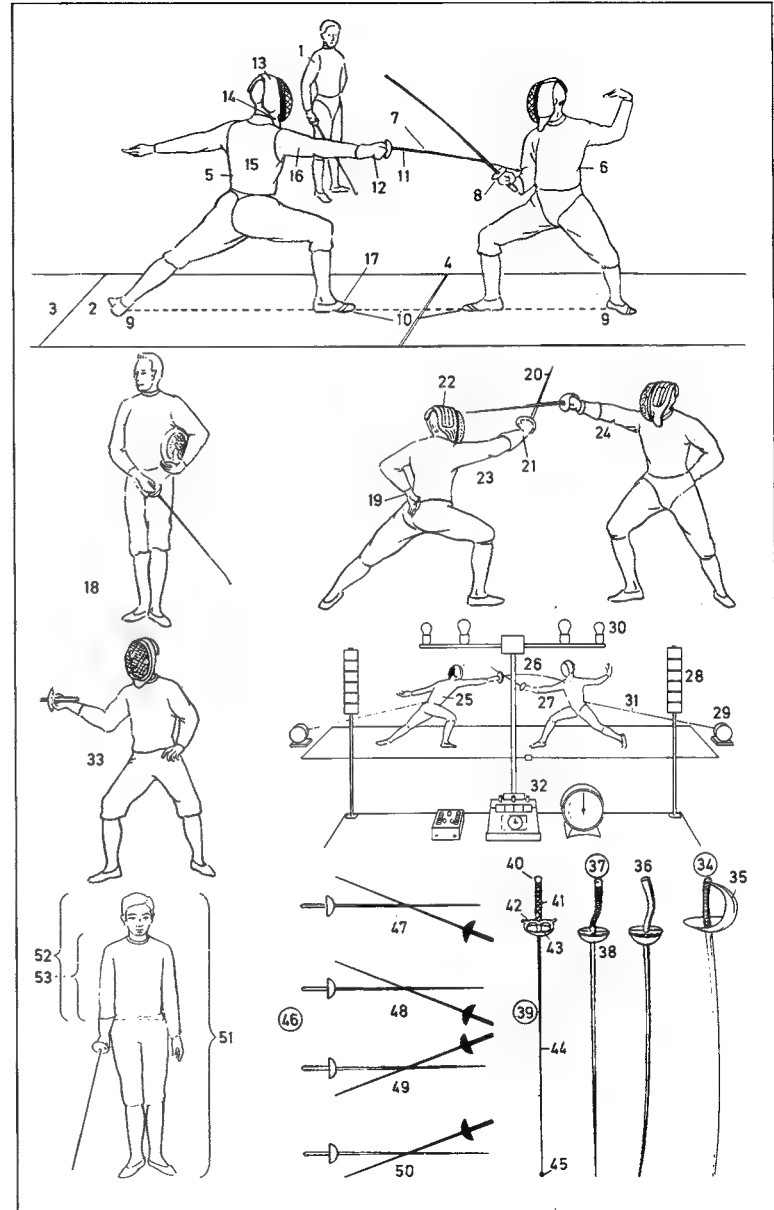

- 1 basic position (starting position)
- 2 running posture
- 3 side straddle
- 4 straddle (forward straddle)
- 5 toe stand
- 6 crouch
- 7 upright kneeling position
- 8 kneeling position, seat on heels
- 9 squat
- 10 L seat (long sitting)
- 11 tailor seat (sitting tailor-style)
- 12 hurdle (hurdle position)
- 13 V-seat
- 14 side split
- 15 forward split
- 16 L-support
- 17 V-support
- 18 straddle seat
- 19 bridge
- 20 kneeling front support
- 21 front support
- 22 back support
- 23 crouch with front support
- 24 arched front support
- 25 side support
- 26 forearm stand (forearm balance)
- 27 handstand
- 28 headstand
- 29 shoulder stand (shoulder balance)
- 30 forward horizontal stand (arabesque)
- 31 rearward horizontal stand
- 32 trunk-bending sideways
- 33 trunk-bending forwards
- 34 arch
- 35 astride jump (butterfly)
- 36 tuck jump
- 37 astride jump
- 38 pike
- 39 scissor jump
- 40 stag jump (stag leap)
- 41 running step
- 42 lunge
- 43 forward pace
- 44 lying on back
- 45 prone position

- 46 lying on side
- 47 holding arms downwards
- 48 holding (extending) arms sideways
- 49 holding arms raised upward
- 50 holding (extending) arms forward
- 51 arms held (extended) backward
- 52 hands clasped behind the head

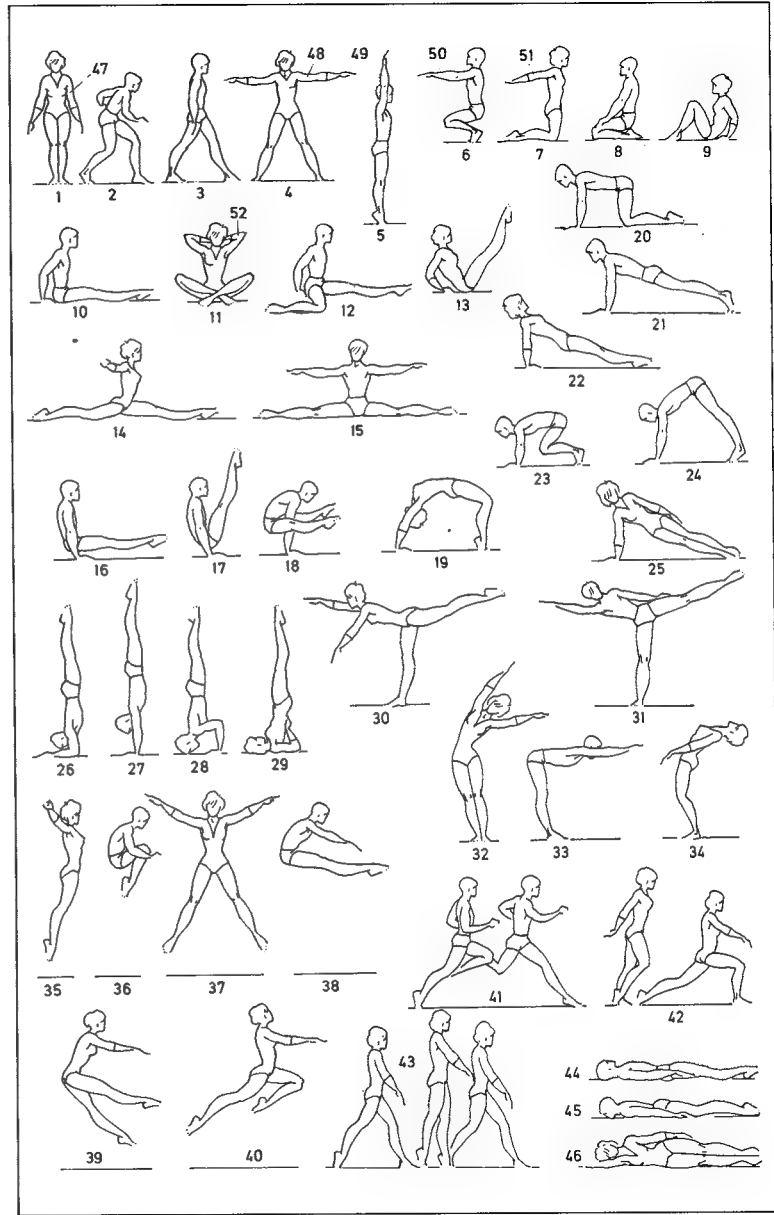

- 1-11 gymnastics apparatus** in men's Olympic gymnastics
- 1 long horse (horse, vaulting horse)
 - 2 parallel bars
 - 3 bar
 - 4 rings (stationary rings)
 - 5 pommel horse (side horse)
 - 6 pommel
 - 7 horizontal bar (high bar)
 - 8 bar
 - 9 upright
 - 10 stay wires
 - 11 floor (12 m × 12 m floor area)
- 12-21 auxiliary apparatus and apparatus for school and club gymnastics**
- 12 springboard (Reuther board)
 - 13 landing mat
 - 14 bench
 - 15 box
 - 16 small box
 - 17 buck
 - 18 mattress
 - 19 climbing rope (rope)
 - 20 wall bars
 - 21 window ladder
- 22-39 positions in relation to the apparatus**
- 22 side, facing
 - 23 side, facing away
 - 24 end, facing
 - 25 end, facing away
 - 26 outside, facing
 - 27 inside, facing
 - 28 front support
 - 29 back support
 - 30 straddle position
 - 31 seated position outside
 - 32 riding seat outside
 - 33 hang
 - 34 reverse hang
 - 35 hang with elbows bent
 - 36 piked reverse hang
 - 37 straight inverted hang
 - 38 straight hang
 - 39 bent hang
- 40-46 grasps (kinds of grasp)**
- 40 overgrasp on the horizontal bar

- 41 undergrasp on the horizontal bar
 - 42 combined grasp on the horizontal bar
 - 43 cross grasp on the horizontal bar
 - 44 rotated grasp on the horizontal bar
 - 45 outside grip on the parallel bars
 - 46 rotated grasp on the parallel bars
 - 47 leather handstrap
- 48-60 apparatus exercises**
- 48 long-fly on the horse
 - 49 rise to straddle on the parallel bars
 - 50 crucifix on the rings
 - 51 scissors (scissors movement) on the pommel horse
 - 52 legs raising into a handstand on the floor
 - 53 squat vault on the horse
 - 54 double leg circle on the pommel horse
 - 55 hip circle backwards on the rings
 - 56 lever hang on the rings
 - 57 rearward swing on the parallel bars
 - 58 forward kip into upper arm hang on the parallel bars
 - 59 backward underswing on the horizontal bar
 - 60 backward grand circle on the horizontal bar
- 61-63 gymnastics kit**
- 61 singlet (vest, Am. undershirt)
 - 62 gym trousers
 - 63 gym shoes
 - 64 wristband

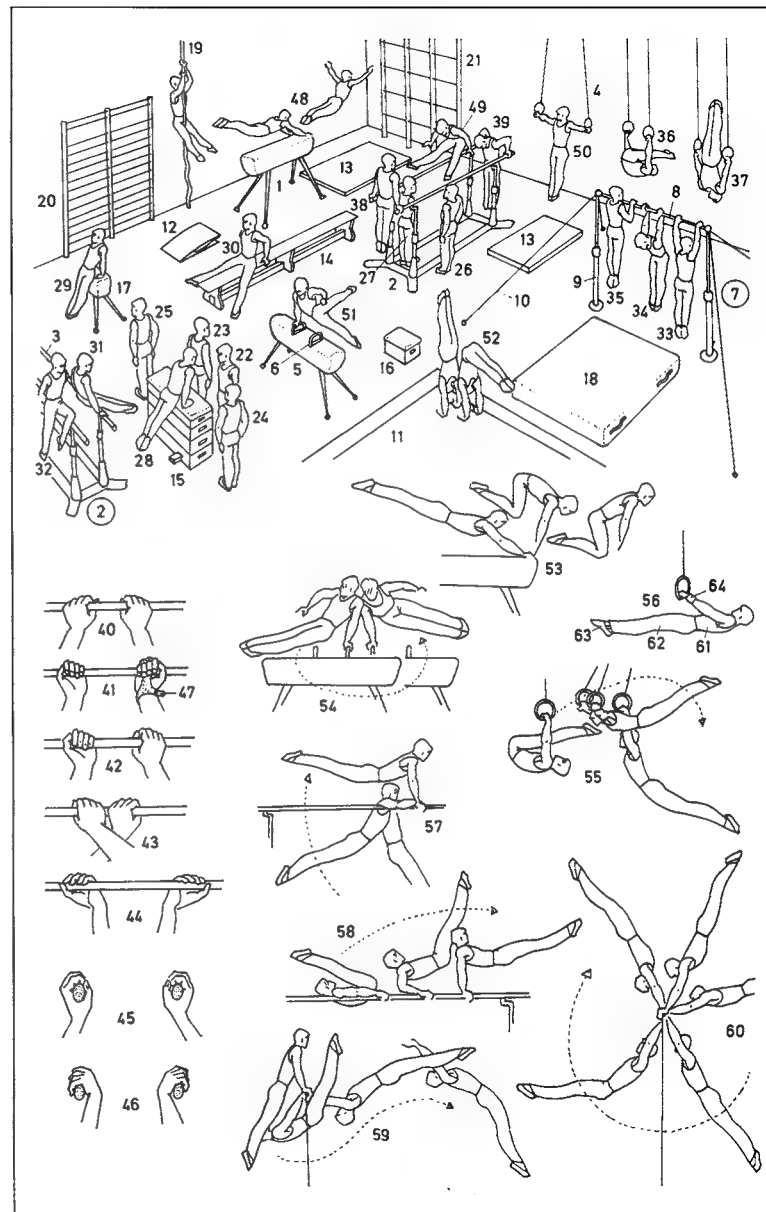

1-6 gymnastics apparatus in women's

Olympic gymnastics

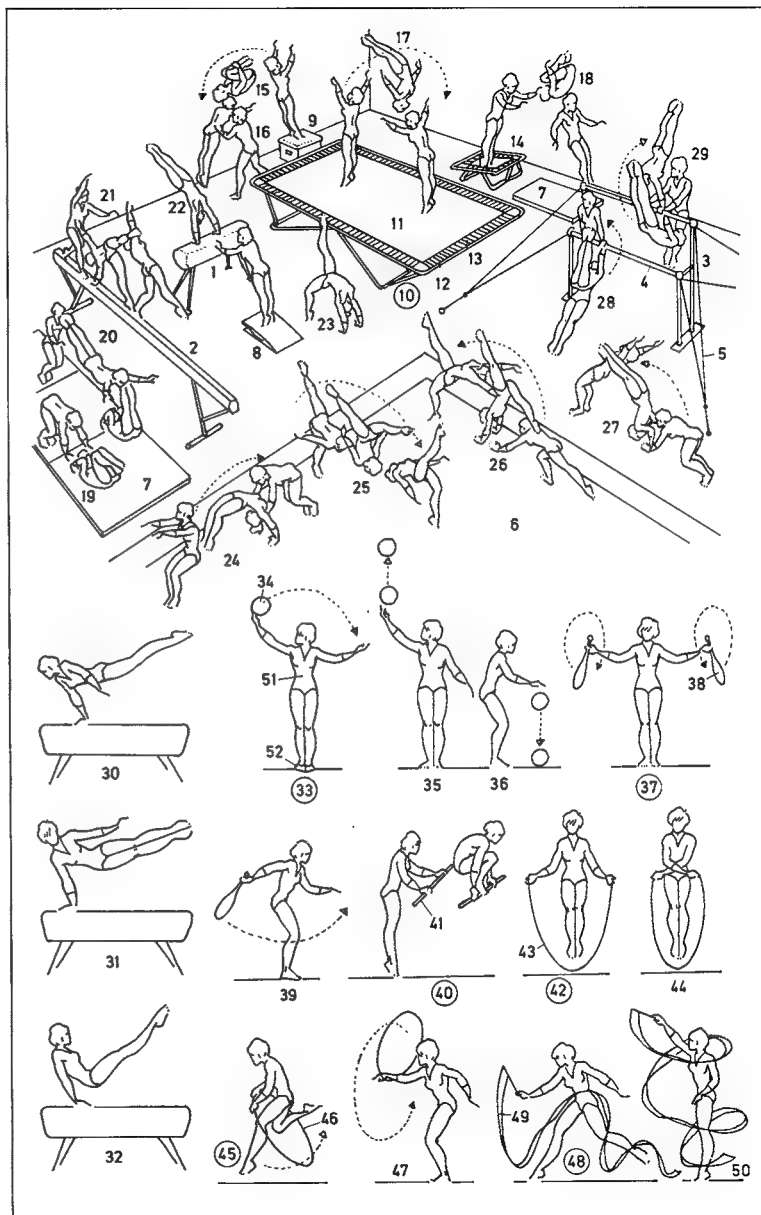
1 horse (vaulting horse)**2** beam**3** asymmetric bars (uneven bars)**4** bar**5** stay wires**6** floor (12 m × 12 m floor area)**7-14 auxiliary apparatus and apparatus for school and club gymnastics****7** landing mat**8** springboard (Reuther board)**9** small box**10** trampoline**11** sheet (web)**12** frame**13** rubber springs**14** springboard trampoline**15-32 apparatus exercises****15** backward somersault**16** spotting position (standing-in position)**17** vertical backward somersault on the trampoline**18** forward somersault on the springboard trampoline**19** forward roll on the floor**20** long-fly to forward roll on the floor**21** cartwheel on the beam**22** handspring on the horse**23** backward walkover**24** back flip (flik-flak) on the floor**25** free walkover forward on the floor**26** forward walkover on the floor**27** headspring on the floor**28** upstart on the asymmetric bars**29** free backward circle on the asymmetric bars**30** face vault over the horse**31** flank vault over the horse**32** back vault (rear vault) over the horse**33-50 gymnastics with hand apparatus****33** hand-to-hand throw**34** gymnastic ball**35** high toss**36** bounce**37** hand circling with two clubs**38** gymnastic club**39** swing**40** tuck jump**41** bar**42** skip**43** rope (skipping rope)**44** criss-cross skip**45** skip through the hoop**46** gymnastic hoop**47** hand circle**48** serpent**49** gymnastic ribbon**50** spiral**51, 52** gymnastics kit**51** leotard**52** gym shoes

- 1-8 running**
1-6 start
 1 starting block
 2 adjustable block (pedal)
 3 start
 4 crouch start
 5 runner, a sprinter; *also*: middle-distance runner, long-distance runner
 6 running track (track), a cinder track or synthetic track
7,8 hurdles (hurdle racing); *sim.*: steeplechase
 7 clearing the hurdle
 8 hurdle
9-41 jumping and vaulting
9-27 high jump
 9 Fosbury flop (Fosbury, flop)
 10 high jumper
 11 body rotation (rotation on the body's longitudinal and latitudinal axes)
 12 shoulder landing
 13 upright
 14 bar (crossbar)
 15 Eastern roll
 16 Western roll
 17 roll
 18 rotation
 19 landing
 20 height scale
 21 Eastern cut-off
 22 scissors (scissor jump)
 23 straddle (straddle jump)
 24 turn
 25 vertical free leg
 26 take-off
 27 free leg
28-36 pole vault
 28 pole (vaulting pole)
 29 pole vaulter (vaulter) in the pull-up phase
 30 swing
 31 crossing the bar
 32 high jump apparatus (high jump equipment)
 33 upright
 34 bar (crossbar)

- 35 box
 36 landing area (landing pad)
37-41 long jump
 37 take-off
 38 take-off board
 39 landing area
 40 hitch-kick
 41 hang
42-47 hammer throw
 42 hammer
 43 hammer head
 44 handle
 45 grip
 46 holding the grip
 47 glove
 48 shot put
 49 shot (weight)
 50 O'Brien technique
51-53 javelin throw
 51 grip with thumb and index finger
 52 grip with thumb and middle finger
 53 horseshoe grip
 54 binding

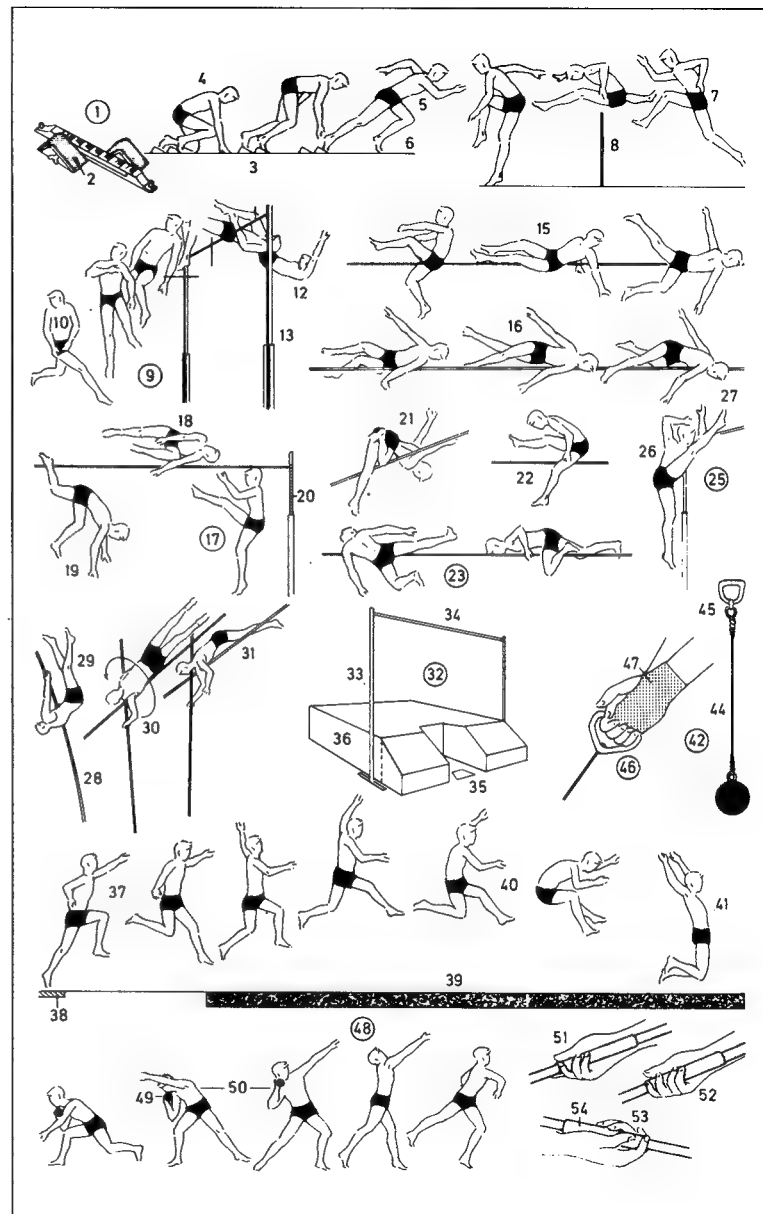

1-5 weightlifting

- 1 squat-style snatch
- 2 weightlifter
- 3 disc (disk) barbell
- 4 jerk with split
- 5 maintained lift

6-12 wrestling

- 6-9 Greco-Roman wrestling
- 6 standing wrestling (wrestling in standing position)
- 7 wrestler
- 8 on-the-ground wrestling (*here*: the referee's position)
- 9 bridge

10-12 freestyle wrestling

- 10 bar arm (arm bar) with grapevine
- 11 double leg lock
- 12 wrestling mat (mat)

13-17 judo (*sim.*: ju-jitsu, jiu-jitsu, ju-jutsu)

- 13 drawing the opponent off balance to the right and forward
- 14 judoka (judoist)
- 15 coloured (*Am.* colored) belt, as a symbol of Dan grade

16 referee

17 judo throw

18, 19 karate

18 karateka

19 side thrust kick, a kicking technique

20-50 boxing (boxing match)

20-24 training apparatus (training equipment)

- 20 spring-supported punch ball
- 21 punch bag (*Am.* punching bag)
- 22 speed ball
- 23 suspended punch ball
- 24 punch ball

25 boxer, an amateur boxer (boxes in a singlet, vest, *Am.* undershirt) or a professional boxer (boxes without singlet)

- 26 boxing glove
- 27 sparring partner
- 28 straight punch (straight blow)
- 29 ducking and sidestepping

30 headguard

31 infighting; *here*: clinch

32 uppercut

33 hook to the head; *here*: right hook

34 punch below the belt, a foul punch (illegal punch, foul)

35-50 boxing match (boxing contest), a title fight (title bout)

35 boxing ring (ring)

36 ropes

37 stay wire (stay rope)

38 neutral corner

39 winner

40 loser by a knockout

41 referee

42 counting out

43 judge

44 second

45 manager

46 gong

47 timekeeper

48 record keeper

49 press photographer

50 sports reporter (reporter)

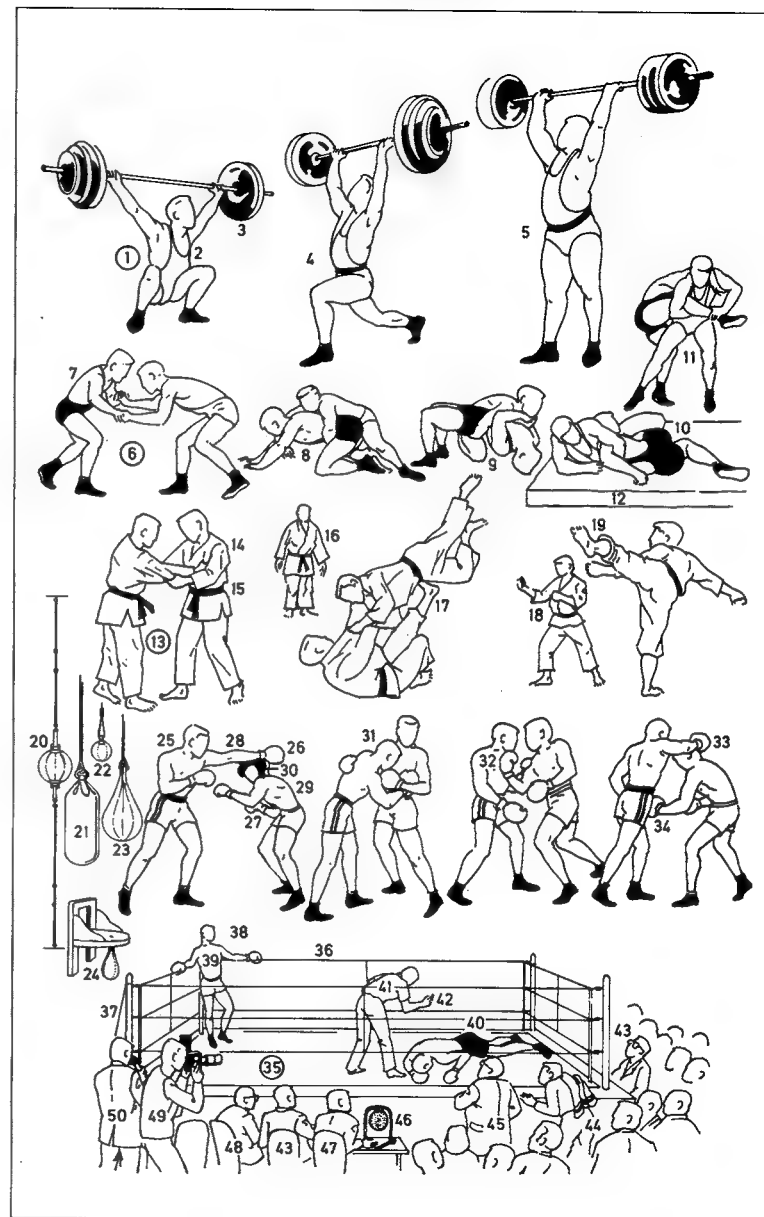

- 1-57 mountaineering** (mountain climbing, Alpinism)
- 1** hut (Alpine Club hut, mountain hut, base)
- 2-13 climbing** (rock climbing) [rock climbing technique]
- 2** rock face (rock wall)
- 3** fissure (vertical, horizontal, or diagonal fissure)
- 4** ledge (rock ledge, grass ledge, scree ledge, snow ledge, ice ledge)
- 5** mountaineer (climber, mountain climber, Alpinist)
- 6** anorak (high-altitude anorak, snowshirt, padded jacket)
- 7** breeches (climbing breeches)
- 8** chimney
- 9** belay (spike, rock spike)
- 10** belay
- 11** rope sling (sling)
- 12** rope
- 13** spur
- 14-21 snow and ice climbing** [snow and ice climbing technique]
- 14** ice slope (firm slope)
- 15** snow and ice climber
- 16** ice axe (*Am. ax*)
- 17** step (ice step)
- 18** snow goggles
- 19** hood (anorak hood)
- 20** cornice (snow cornice)
- 21** ridge (ice ridge)
- 22-27 rope** (roped party)
- 22** glacier
- 23** crevasse
- 24** snow bridge
- 25** leader
- 26** second man (belayer)
- 27** third man (non-belayer)
- 28-30 roping down** (abseiling, rapelling)
- 28** abseil sling
- 29** sling seat
- 30** Dülfer seat

- 31-57 mountaineering equipment** (climbing equipment, snow and ice climbing equipment)
- 31** ice axe (*Am. ax*)
- 32** wrist sling
- 33** pick
- 34** adze (*Am. adz*)
- 35** karabiner hole
- 36** short-shafted ice axe (*Am. ax*)
- 37** hammer axe (*Am. ax*)
- 38** general-purpose piton
- 39** abseil piton (ringed piton)
- 40** ice piton (semi-tubular screw ice piton, corkscrew piton)
- 41** drive-in ice piton
- 42** mountaineering boot
- 43** corrugated sole
- 44** climbing boot
- 45** roughened stiff rubber upper
- 46** karabiner
- 47** screwgate
- 48** crampons (lightweight crampons, twelve-point crampons, ten-point crampons)
- 49** front points
- 50** point guards
- 51** crampon strap
- 52** crampon cable fastener
- 53** safety helmet (protective helmet)
- 54** helmet lamp
- 55** snow gaiters
- 56** climbing harness
- 57** sit harness

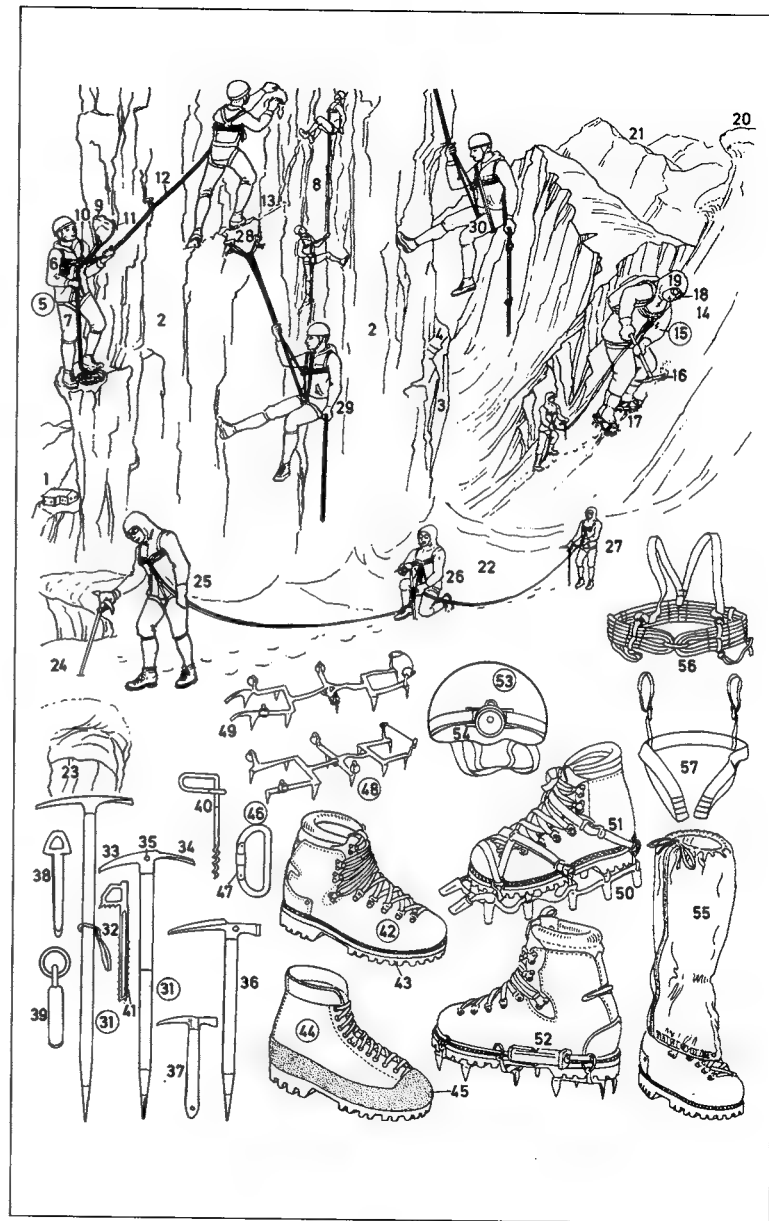

1-72 skiing

- 1 compact ski
- 2 safety binding (release binding)
- 3 strap
- 4 steel edge
- 5 ski stick (ski pole)
- 6 grip
- 7 loop
- 8 basket
- 9 ladies' one-piece ski suit
- 10 skiing cap (ski cap)
- 11 skiing goggles
- 12 cemented sole ski boot
- 13 crash helmet
- 14-20 cross-country equipment
- 14 cross-country ski
- 15 cross-country rat trap binding
- 16 cross-country boot
- 17 cross-country gear
- 18 peaked cap
- 19 sunglasses
- 20 cross-country poles made of bamboo
- 21-24 ski-waxing equipment
- 21 ski wax
- 22 waxing iron (blowlamp, blowtorch)
- 23 waxing cork
- 24 wax scraper
- 25 downhill racing pole
- 26 herringbone, for climbing a slope
- 27 sidestep, for climbing a slope
- 28 ski bag
- 29 slalom
- 30 gate pole
- 31 racing suit
- 32 downhill racing
- 33 'egg' position, the ideal downhill racing position
- 34 downhill ski
- 35 ski jumping
- 36 lean forward
- 37 number
- 38 ski jumping ski
- 39 grooves (3 to 5 grooves)
- 40 cable binding
- 41 ski jumping boots
- 42 cross-country
- 43 cross-country stretch-suit

- 44 course
- 45 course-marking flag
- 46 layers of a modern ski
- 47 special core
- 48 laminates
- 49 stabilizing layer (stabilizer)
- 50 steel edge
- 51 aluminium (*Am.* aluminum) upper edge
- 52 synthetic bottom (artificial bottom)
- 53 safety jet
- 54-56 parts of the binding
- 54 automatic heel unit
- 55 toe unit
- 56 ski stop
- 57-63 ski lift
- 57 double chair lift
- 58 safety bar with footrest
- 59 ski lift
- 60 track
- 61 hook
- 62 automatic cable pulley
- 63 haulage cable
- 64 slalom
- 65 open gate
- 66 closed vertical gate
- 67 open vertical gate
- 68 transversal chicane
- 69 hairpin
- 70 elbow
- 71 corridor
- 72 Allais chicane



1-26 ice skating

- 1 ice skater, a solo skater
- 2 tracing leg
- 3 free leg
- 4 pair skaters
- 5 death spiral
- 6 pivot
- 7 stag jump (stag leap)
- 8 jump-sit-spin
- 9 upright spin
- 10 holding the foot
- 11-19 compulsory figures
- 11 curve eight
- 12 change
- 13 three
- 14 double-three
- 15 loop
- 16 change loop
- 17 bracket
- 18 counter
- 19 rocker
- 20-25 ice skates
- 20 speed skating set (speed skate)
- 21 edge
- 22 hollow grinding (hollow ridge, concave ridge)
- 23 ice hockey set (ice hockey skate)
- 24 ice skating boot
- 25 skate guard
- 26 speed skater
- 27, 28 skate sailing
- 27 skate sailor
- 28 hand sail
- 29-37 ice hockey
- 29 ice hockey player
- 30 ice hockey stick
- 31 stick handle
- 32 stick blade
- 33 shin pad
- 34 headgear (protective helmet)
- 35 puck, a vulcanized rubber disc (disk)
- 36 goalkeeper
- 37 goal
- 38-40 ice-stick shooting (Bavarian curling)

38 ice-stick shooter (Bavarian curler)

- 39 ice stick
- 40 block
- 41-43 curling
- 41 curler
- 42 curling stone (granite)
- 43 curling brush (curling broom, besom)
- 44-46 ice yachting (iceboating, ice sailing)
- 44 ice yacht (iceboat)
- 45 steering runner
- 46 outrigger runner

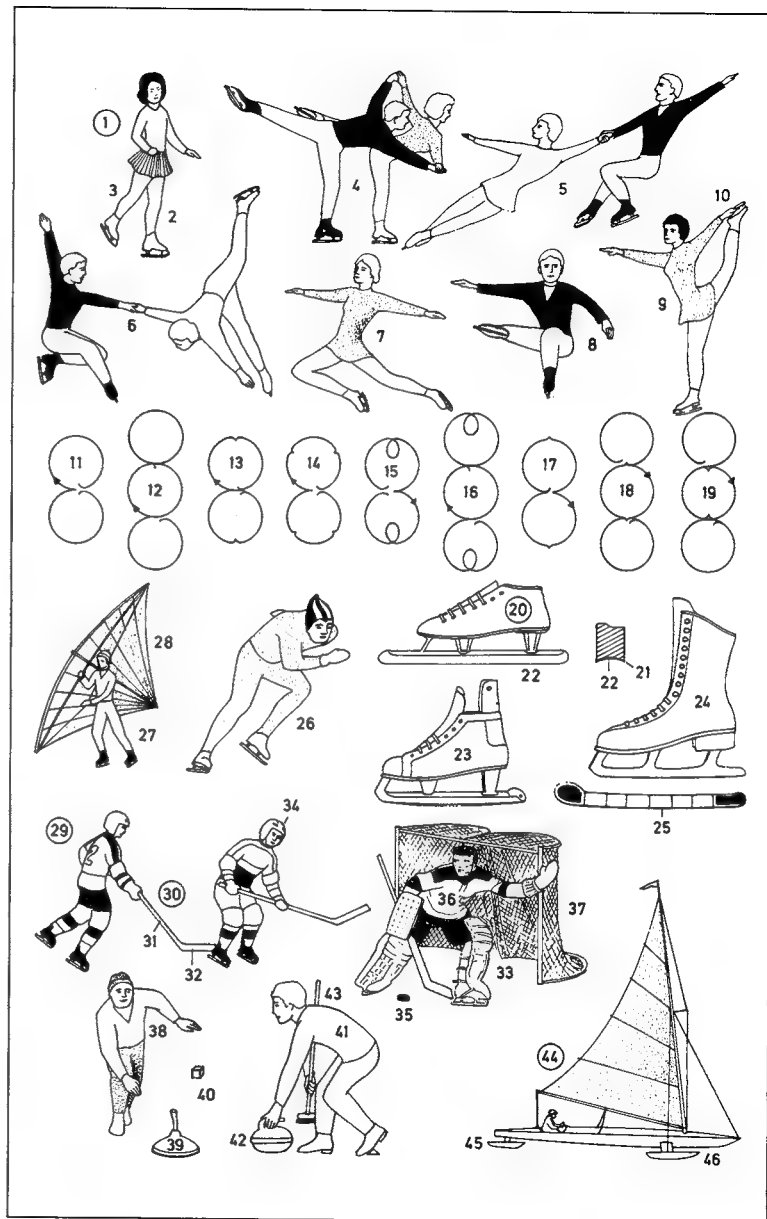

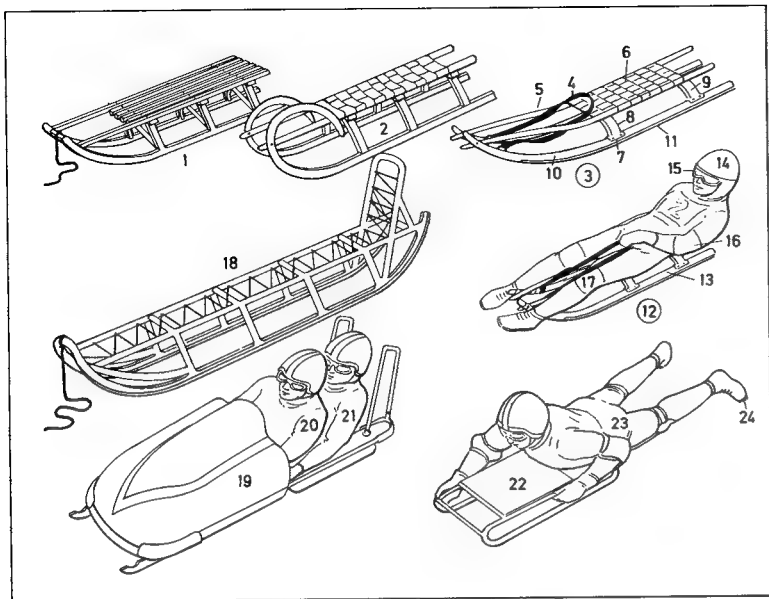

- 1 toboggan (sledge, *Am.* sled)
 2 toboggan (sledge, *Am.* sled) with seat of plaid straps
 3 junior luge toboggan (junior luge, junior toboggan)
 4 rein
 5 bar (strut)
 6 seat
 7 bracket
 8 front prop
 9 rear prop
 10 movable runner
 11 metal face
 12 luge tobogganer
 13 luge toboggan (luge, toboggan)
 14 crash helmet
 15 goggles
 16 elbow pad
 17 knee pad
 18 Nansen sledge, a polar sledge
 19-21 bobsleigh (bobsledding)
 19 bobsleigh (bobsled), a two-man bobsleigh (a boblet)
 20 steersman
 21 brakeman
 22-24 skeleton tobogganing (Cresta tobogganing)
 22 skeleton (skeleton toboggan)
 23 skeleton rider
 24 rake, for braking and steering

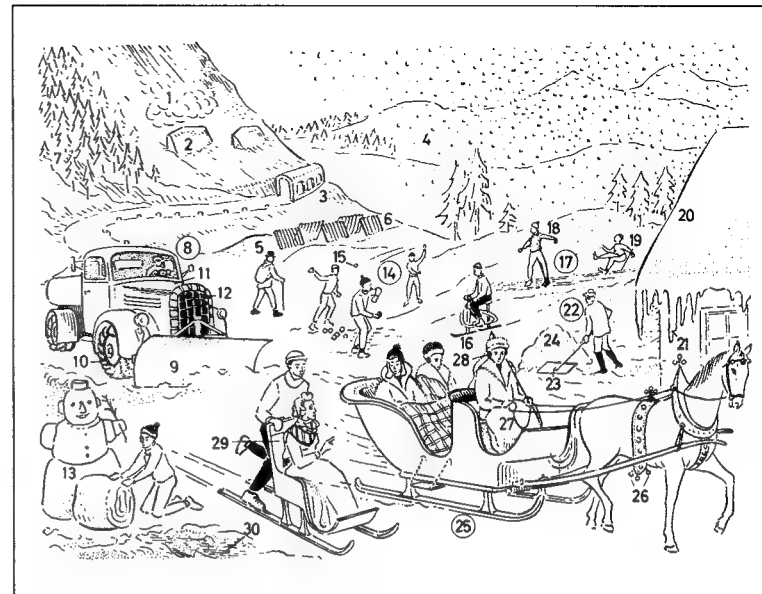

- 1 avalanche (snow avalanche, *Am.* snowslide); *kinds:* wind avalanche, ground avalanche
 2 avalanche wall, a deflecting wall (diverting wall); *sim.:* avalanche wedge
 3 avalanche gallery
 4 snowfall
 5 snowdrift
 6 snow fence
 7 avalanche forest [planted as protection against avalanches]
 8 street-cleaning lorry (street cleaner)
 9 snow plough (*Am.* snowplow) attachment
 10 snow chain (skid chain, tyre chain, *Am.* tire chain)
 11 radiator bonnet (*Am.* radiator hood)
 12 radiator shutter and shutter opening (louvre shutter)
 13 snowman
 14 snowball fight
 15 snowball
 16 ski bob
 17 slide
 18 boy, sliding
 19 icy surface (icy ground)
 20 covering of snow (on the roof)
 21 icicle
 22 man clearing snow
 23 snow push (snow shovel)
 24 heap of snow
 25 horse-drawn sleigh (horse sleigh)
 26 sleigh bells (bells, set of bells)
 27 foot muff (*Am.* foot bag)
 28 earmuff
 29 handsledge (tread sledge); *sim.:* push sledge
 30 slush

- 1-13 **skittles**
 1-11 skittle frame
 1 front pin (front)
 2 left front second pin (left front second)
 3 running three [left]
 4 right front second pin (right front second)
 5 running three [right]
 6 left corner pin (left corner), a corner (copper)
 7 landlord
 8 right corner pin (right corner), a corner (copper)
 9 back left second pin (back left second)
 10 back right second pin (back right second)
 11 back pin (back)
 12 pin
 13 landlord
 14-20 **tenpin bowling**
 14 frame
 15 bowling ball (ball with finger holes)
 16 finger hole
 17-20 deliveries
 17 straight ball
 18 hook ball (hook)
 19 curve
 20 back-up ball (back-up)
 21 **boules; sim.:** Italian game of bocce, green bowls (bowls)
 22 boules player
 23 jack (target jack)
 24 grooved boule
 25 group of players
 26 **rifle shooting**
 27-29 shooting positions
 27 standing position
 28 kneeling position
 29 prone position
 30-33 targets
 30 target for 50 m events (50 m target)
 31 circle
 32 target for 100 m events (100 m target)
 33 bobbing target (turning target, running-board target)
 34-39 ammunition
 34 air rifle cartridge
 35 rimfire cartridge for zimmerstutzen (indoor target rifle), a smallbore German single-shot rifle
 36 case head
 37 caseless round
 38 .22 long rifle cartridge
 39 .222 Remington cartridge
 40-49 sporting rifles
 40 air rifle
 41 optical sight

- 42 front sight (foresight)
 43 smallbore standard rifle
 44 international smallbore free rifle
 45 palm rest for standing position
 46 butt plate with hook
 47 butt with thumb hole
 48 smallbore rifle for bobbing target (turning target)
 49 telescopic sight (riflescope, telescope sight)
 50 optical ring sight
 51 optical ring and bead sight
 52-66 **archery** (target archery)
 52 shot
 53 archer
 54 competition bow
 55 riser
 56 point-of-aim mark
 57 grip (handle)
 58 stabilizer
 59 bow string (string)
 60 arrow
 61 pile (point) of the arrow
 62 fletching
 63 nock
 64 shaft
 65 cresting
 66 target
 67 Basque game of **pelota (jai alai)**
 68 pelota player
 69 wicker basket (cesta)
 70-78 **skeet** (skeet shooting), a kind of clay pigeon shooting
 70 skeet over-and-under shotgun
 71 muzzle with skeet choke
 72 ready position on call
 73 firing position
 74 shooting range
 75 high house
 76 low house
 77 target's path
 78 shooting station (shooting box)
 79 **aero wheel**
 80 handle
 81 footrest
 82 **go-karting** (karting)
 83 go-kart (kart)
 84 number plate (number)
 85 pedals
 86 pneumatic tyre (*Am. tire*)
 87 petrol tank (*Am. gasoline tank*)
 88 frame
 89 steering wheel
 90 bucket seat
 91 protective bulkhead
 92 two-stroke engine
 93 silencer (*Am. muffler*)

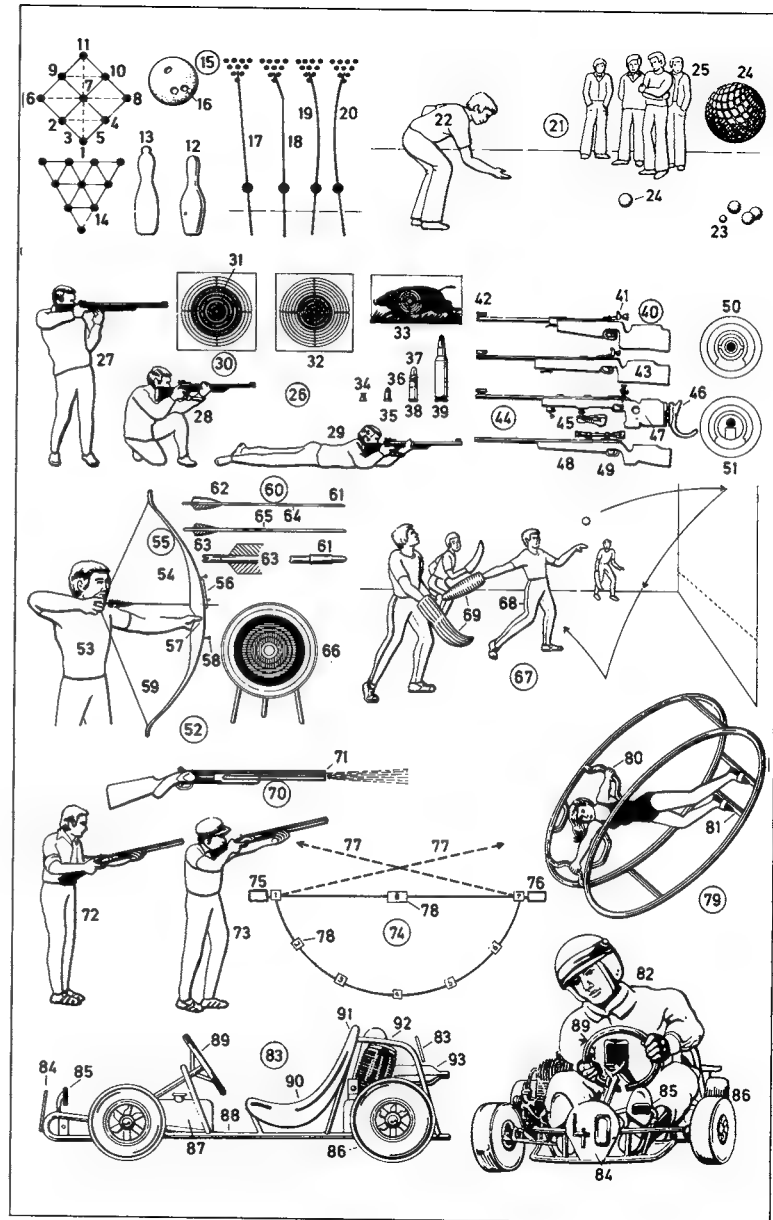

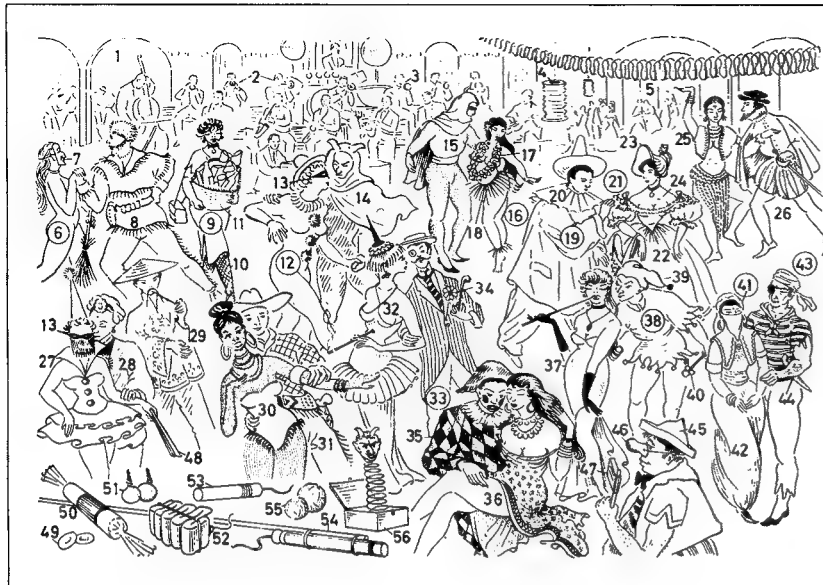

1-48 masked ball (masquerade, fancy-dress ball)

- 1 ballroom
- 2 dance band
- 3 pop musician
- 4 paper lantern
- 5 festoon (string of decorations)
- 6-48 disguise (fancy dress) at the masquerade
- 6 witch
- 7 mask
- 8 fur trapper (trapper)
- 9 Apache girl
- 10 net stocking
- 11 first prize in the tombola (raffle), a hamper
- 12 pierette
- 13 half mask (domino)
- 14 devil
- 15 domino
- 16 hula-hula girl (Hawaii girl)
- 17 garland
- 18 grass skirt (hula skirt)

- 19 pierrot
- 20 ruff
- 21 midinette
- 22 Biedermeier dress
- 23 poke bonnet
- 24 décolletage with beauty spot
- 25 bayadère (Hindu dancing girl)
- 26 grandee
- 27 Columbine
- 28 maharaja (maharajah)
- 29 mandarin, a Chinese dignitary
- 30 exotic girl (exotic)
- 31 cowboy; *sim.*: gaucho (vaquero)
- 32 vamp, in fancy dress
- 33 dandy (fop, beau)
- 34 rosette
- 35 harlequin
- 36 gypsy (gypsy) girl
- 37 cocotte (demi-monde, demi-mondaine, demi-rep)
- 38 owl-glass, a fool (jester, buffoon)
- 39 foolscap (jester's cap and bells)
- 40 rattle



41 odalisque, Eastern female slave in Sultan's seraglio

- 42 chalwar (pantaloons)
- 43 pirate (buccaneer)
- 44 tattoo
- 45 paper hat
- 46 false nose
- 47 clapper (rattle)
- 48 slapstick
- 49-54 fireworks
- 49 percussion cap
- 50 cracker
- 51 banger
- 52 jumping jack
- 53 cannon cracker (maroon, maroon)
- 54 rocket
- 55 paper ball
- 56 jack-in-the-box
- 57-70 **carnival procession**
- 57 carnival float (carnival truck)
- 58 King Carnival

59 bauble (fool's sceptre, *Am.* scepter)

- 60 fool's badge
- 61 Queen Carnival
- 62 confetti
- 63 giant
- 64 beauty queen
- 65 fairy-tale figure
- 66 paper streamer
- 67 majorette
- 68 king's guard
- 69 buffoon, a clown
- 70 lansquenet's drum

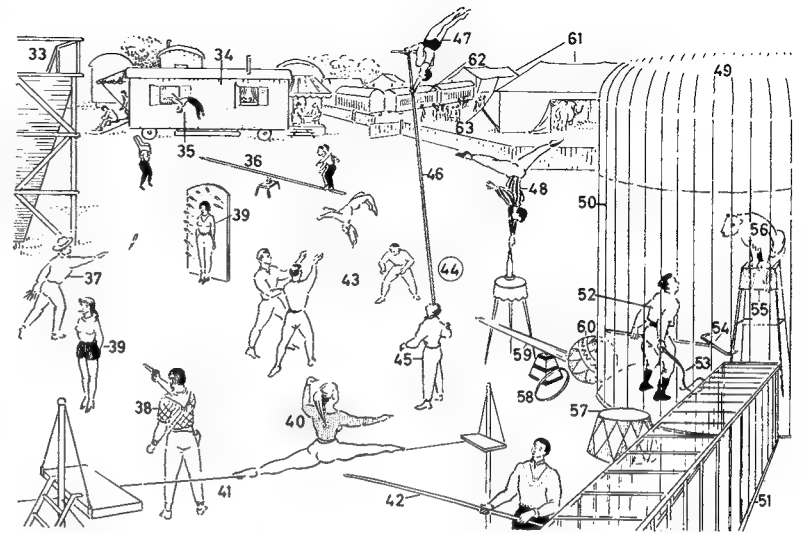
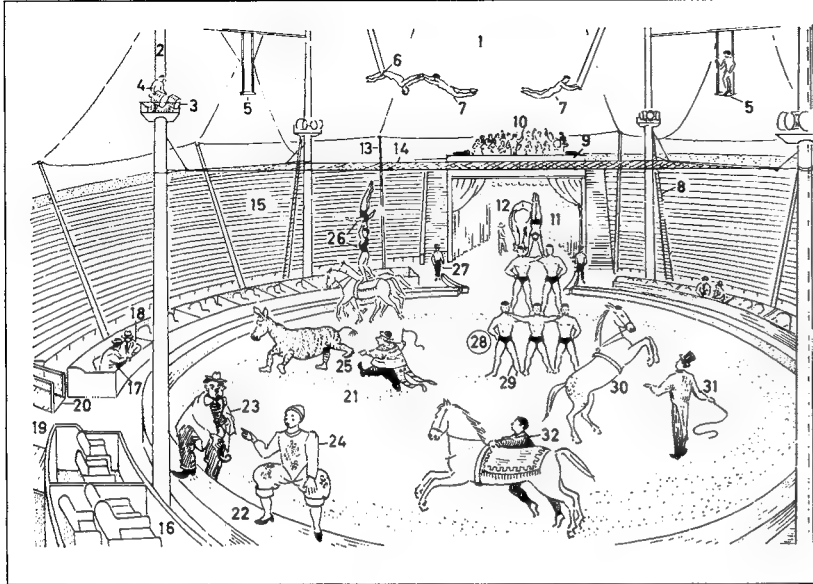

1-63 travelling (*Am.* traveling) circus

1 circus tent (big top), a four-pole tent

2 tent pole

3 spotlight

4 lighting technician

5 trapeze platform

6 trapeze

7 trapeze artist

8 rope ladder

9 bandstand

10 circus band

11 ring entrance (arena entrance)

12 wings

13 tent prop (prop)

14 safety net

15 seats for the spectators

16 circus box

17 circus manager

18 agent

19 entrance and exit

20 steps

21 ring (arena)

22 ring fence

23 musical clown (clown)

24 clown

25 comic turn (clown act), a circus act

26 circus riders (bareback riders)

27 ring attendant, a circus attendant

28 pyramid

29 support

30, 31 performance by liberty horses

30 circus horse, performing the levade (pesade)

31 ringmaster

32 vaulter

33 emergency exit

34 caravan (circus caravan, *Am.* trailer)

35 springboard acrobat (springboard artist)

36 springboard

37 knife thrower

38 circus marksman

39 assistant

40 tightrope dancer

41 tightrope

42 balancing pole

43 throwing act

44 balancing act

45 support

46 pole (bamboo pole)

47 acrobat

48 equilibrist (balancer)

49 wild animal cage, a round cage

50 bars of the cage

51 passage (barred passage, passage for the wild animals)

52 tamer (wild animal tamer)

53 whip

54 fork

55 pedestal

56 wild animal (tiger, lion)

57 stand

58 hoop (jumping hoop)

59 seesaw

60 ball

61 camp

62 cage caravan

63 menagerie

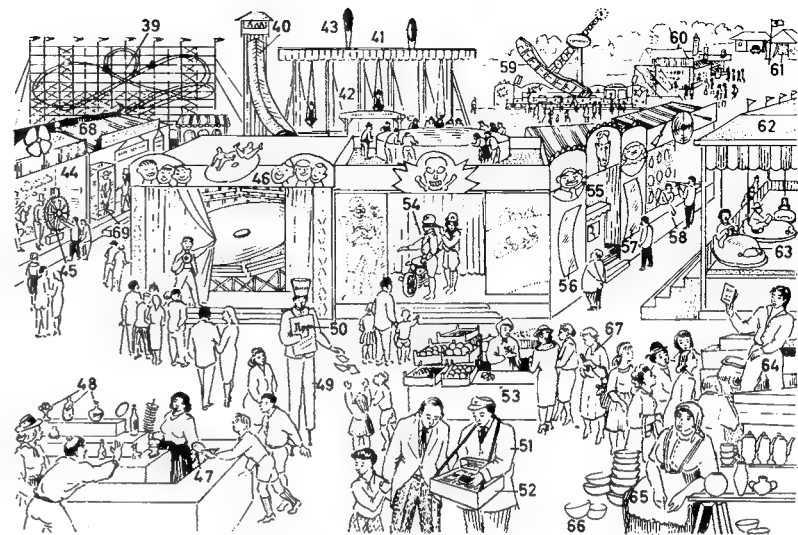
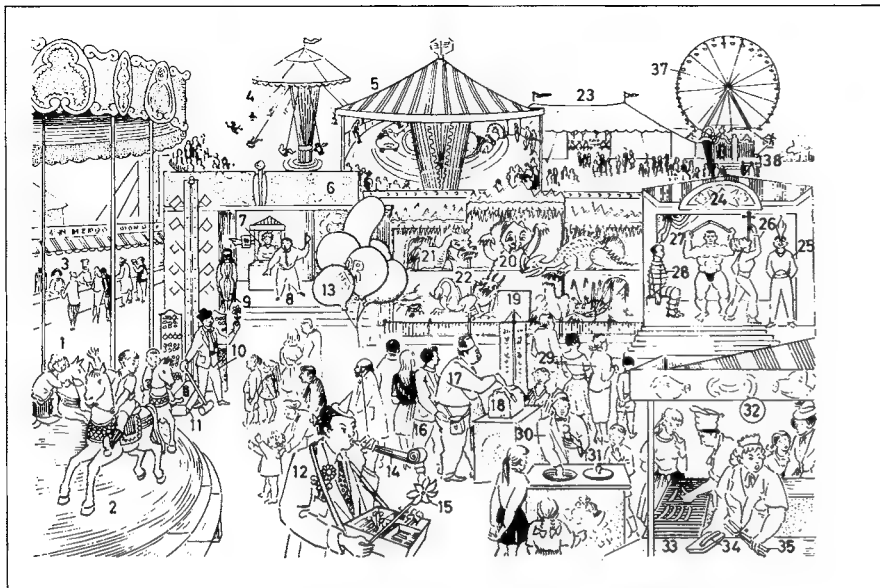

1-69 fair (annual fair)

- 1 fairground
- 2 children's merry-go-round (whirligig), a roundabout (*Am.* carousel)
- 3 refreshment stall (drinks stall)
- 4 chairplane
- 5 up-and-down roundabout
- 6 show booth (booth)
- 7 box (box office)
- 8 barker
- 9 medium
- 10 showman
- 11 try-your-strength machine
- 12 hawker
- 13 balloon
- 14 paper serpent
- 15 windmill
- 16 pickpocket (thief)
- 17 vendor
- 18 nougat
- 19 ghost train
- 20 monster

- 21 dragon
- 22 monster
- 23 beer marquee
- 24 sideshow
- 25-28 travelling (*Am.* traveling) artistes (travelling show people)
- 25 fire eater
- 26 sword swallower
- 27 strong man
- 28 escapologist
- 29 spectators
- 30 ice-cream vendor (ice-cream man)
- 31 ice-cream cornet, with ice cream
- 32 sausage stand
- 33 grill (*Am.* broiler)
- 34 bratwurst (grilled sausage, *Am.* broiled sausage)
- 35 sausage tongs
- 36 fortune teller
- 37 big wheel (Ferris wheel)
- 38 orchestion (automatic organ), an automatic musical instrument
- 39 scenic railway (switchback)

- 40 toboggan slide (chute)
- 41 swing boats
- 42 swing boat, turning full circle
- 43 full circle
- 44 lottery booth (tombola booth)
- 45 wheel of fortune
- 46 devil's wheel (typhoon wheel)
- 47 throwing ring (quoit)
- 48 prizes
- 49 sandwich man on stilts
- 50 sandwich board (placard)
- 51 cigarette seller, an itinerant trader (a hawker)
- 52 tray
- 53 fruit stall
- 54 wall-of-death rider
- 55 hall of mirrors
- 56 concave mirror
- 57 convex mirror
- 58 shooting gallery
- 59 giant swing boat
- 60 junk stalls (second-hand stalls)
- 61 first aid tent (first aid post)

- 62 dodgems (bumper cars)
- 63 dodgem (bumper car)
- 64-66 pottery stand
- 64 barker
- 65 market woman
- 66 pottery
- 67 visitors to the fair
- 68 waxworks
- 69 wax figure

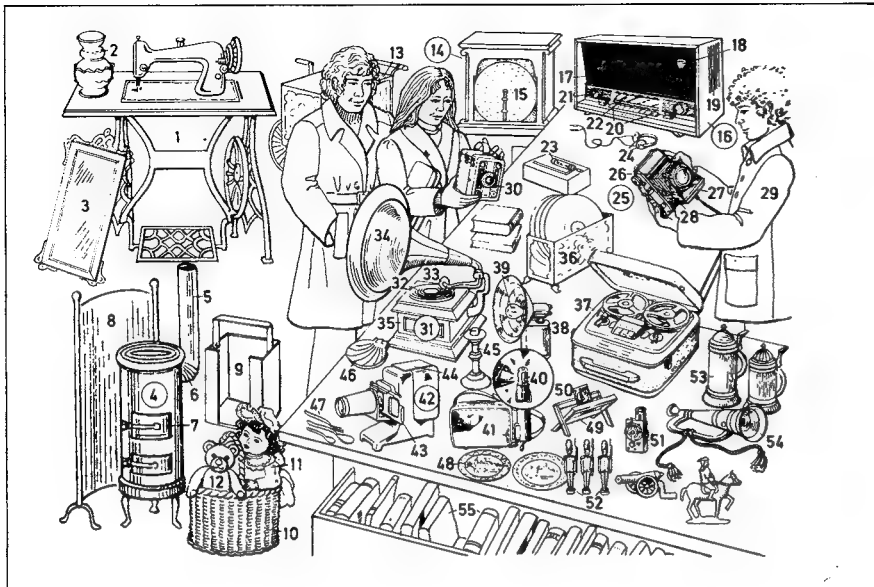

- 1 treadle sewing machine
- 2 flower vase
- 3 wall mirror
- 4 cylindrical stove
- 5 stovepipe
- 6 stovepipe elbow
- 7 stove door
- 8 stove screen
- 9 coal scuttle
- 10 firewood basket
- 11 doll
- 12 teddy bear
- 13 barrel organ
- 14 orchestron
- 15 metal disc (disk)
- 16 radio (radio set, *loc.*: 'steam radio'), a superheterodyne (superhet)
- 17 baffle board
- 18 'magic eye', a tuning indicator valve
- 19 loudspeaker aperture
- 20 station selector buttons (station preset buttons)
- 21 tuning knob
- 22 frequency bands

- 23 crystal detector (crystal set)
- 24 headphones (headset)
- 25 folding camera
- 26 bellows
- 27 hinged cover
- 28 spring extension
- 29 salesman
- 30 box camera
- 31 gramophone
- 32 record (gramophone record)
- 33 needle head with gramophone needle
- 34 horn
- 35 gramophone box
- 36 record rack
- 37 portable tape recorder
- 38 flashgun
- 39 flash bulb
- 40, 41 electronic flash (electronic flashgun)
- 40 flash head
- 41 accumulator
- 42 slide projector
- 43 slide holder
- 44 lamphouse

- 45 candlestick
- 46 scallop shell
- 47 cutlery
- 48 souvenir plate
- 49 drying rack for photographic plates
- 50 photographic plate
- 51 delayed-action release
- 52 tin soldiers (*sim.*: lead soldiers)
- 53 beer mug (stein)
- 54 bugle
- 55 second-hand books
- 56 grandfather clock
- 57 clock case
- 58 pendulum
- 59 time weight
- 60 striking weight
- 61 rocking chair
- 62 sailor suit
- 63 sailor's hat
- 64 washing set
- 65 washing basin
- 66 water jug
- 67 washstand
- 68 dolly
- 69 washtub

- 70 washboard
- 71 humming top
- 72 slate
- 73 pencil box
- 74 adding machine
- 75 paper roll
- 76 number keys
- 77 abacus
- 78 inkwell, with lid
- 79 typewriter
- 80 [hand-operated] calculating machine (calculator)
- 81 operating handle
- 82 result register (product register)
- 83 rotary counting mechanism (rotary counter)
- 84 kitchen scales
- 85 waist slip (underskirt)
- 86 wooden handcart
- 87 wall clock
- 88 bed warmer
- 89 milk churn

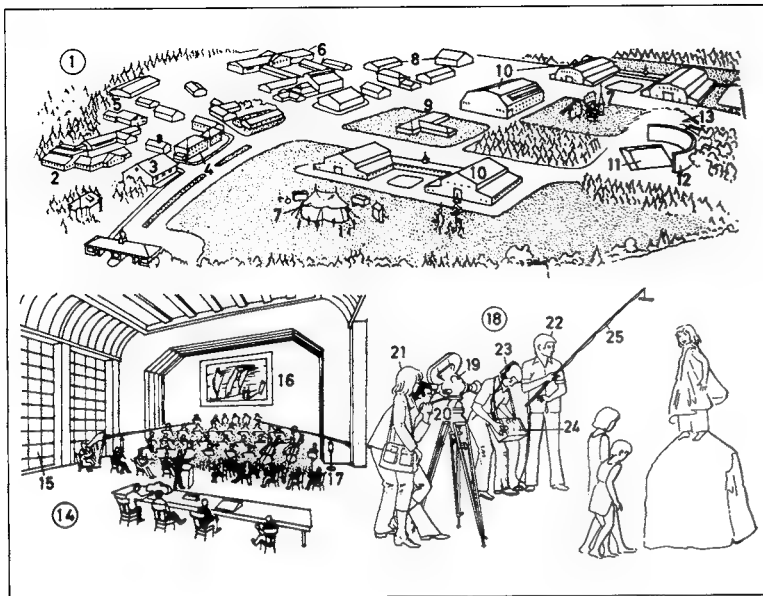

- 1-13 film studios** (studio complex, *Am.* movie studios)
1 lot (studio lot)
2 processing laboratories (film laboratories, motion picture laboratories)
3 cutting rooms
4 administration building (office building, offices)
5 film (motion picture) storage vault (film library, motion picture library)
6 workshop
7 film set (*Am.* movie set)
8 power house
9 technical and research laboratories
10 groups of stages
11 concrete tank for marine sequences
12 cyclorama
13 hill
14-60 shooting (filming)
14 music recording studio (music recording theatre, *Am.* theater)
15 'acoustic' wall lining

- 16** screen (projection screen)
17 film orchestra
18 exterior shooting (outdoor shooting, exterior filming, outdoor filming)
19 camera with crystal-controlled drive
20 cameraman
21 assistant director
22 boom operator (boom swinger)
23 recording engineer (sound recordist)
24 portable sound recorder with crystal-controlled drive
25 microphone boom
26-60 shooting (filming) in the studio (on the sound stage, on the stage, in the filming hall)
26 production manager
27 leading lady (film actress, film star, star)
28 leading man (film actor, film star, star)
29 film extra (extra)
30 arrangement of microphones for stereo and sound effects

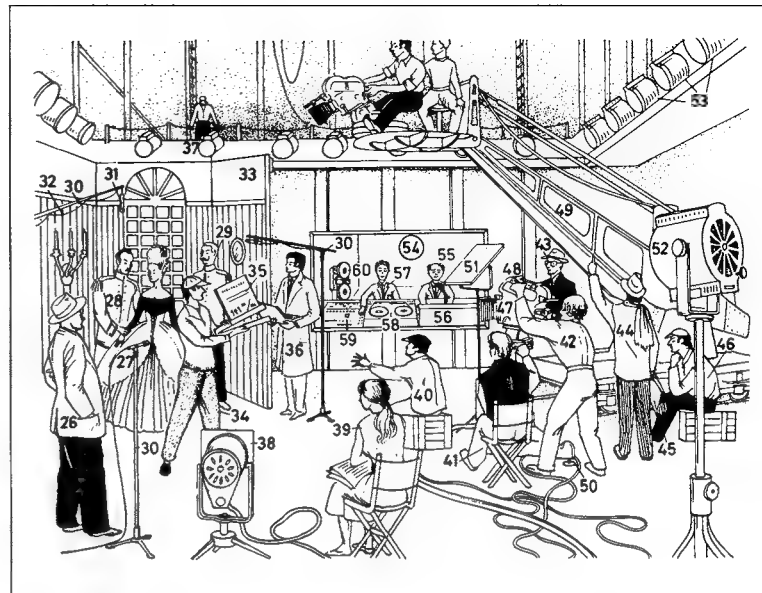

- 31** studio microphone
32 microphone cable
33 side flats and background
34 clapper boy
35 clapper board (clapper) with slates (boards) for the film title, shot number (scene number), and take number
36 make-up artist (hairstylist)
37 lighting electrician (studio electrician, lighting man, *Am.* gaffer)
38 diffusing screen
39 continuity girl (script girl)
40 film director (director)
41 cameraman (first cameraman)
42 camera operator, an assistant cameraman (camera assistant)
43 set designer (art director)
44 director of photography
45 filmscript (script, shooting script, *Am.* movie script)
46 assistant director
47 soundproof film camera (soundproof motion picture camera), a wide screen camera (cinemascope camera)

- 48** soundproof housing (soundproof cover, blimp)
49 camera crane (dolly)
50 hydraulic stand
51 mask (screen) for protection from spill light (gobo)
52 tripod spotlight (fill-in light, filler light, fill light, filler)
53 spotlight catwalk
54 recording room
55 recording engineer (sound recordist)
56 mixing console (mixing desk)
57 sound assistant (assistant sound engineer)
58 magnetic sound recording equipment (magnetic sound recorder)
59 amplifier and special effects equipment, e.g. for echo and sound effects
60 sound recording camera (optical sound recorder)

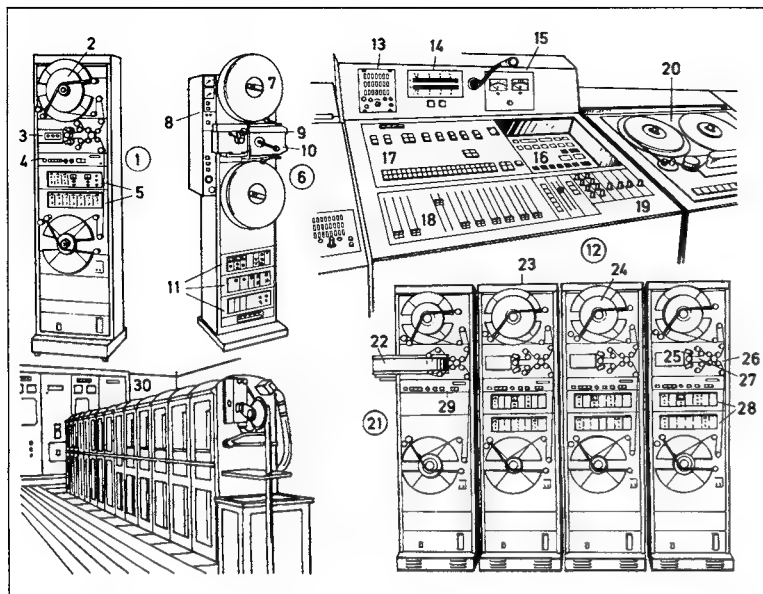

1-46 sound recording and re-recording (dubbing)

- 1 magnetic sound recording equipment (magnetic sound recorder)
- 2 magnetic film spool
- 3 magnetic head support assembly
- 4 control panel
- 5 magnetic sound recording and playback amplifier
- 6 optical sound recorder (sound recording camera, optical sound recording equipment)
- 7 daylight film magazine
- 8 control and monitoring panel
- 9 eyepiece for visual control of optical sound recording
- 10 deck
- 11 recording amplifier and mains power unit
- 12 control desk (control console)
- 13 monitoring loudspeaker (control loudspeaker)
- 14 recording level indicators
- 15 monitoring instruments
- 16 jack panel
- 17 control panel
- 18 sliding control
- 19 equalizer
- 20 magnetic sound deck
- 21 mixer for magnetic film
- 22 film projector
- 23 recording and playback equipment
- 24 film reel (film spool)
- 25 head support assembly for the recording head, playback head, and erase head
- 26 film transport mechanism
- 27 synchronizing filter
- 28 magnetic sound amplifier
- 29 control panel
- 30 film-processing machines (film-developing machines) in the processing laboratory (film laboratory, motion picture laboratory)

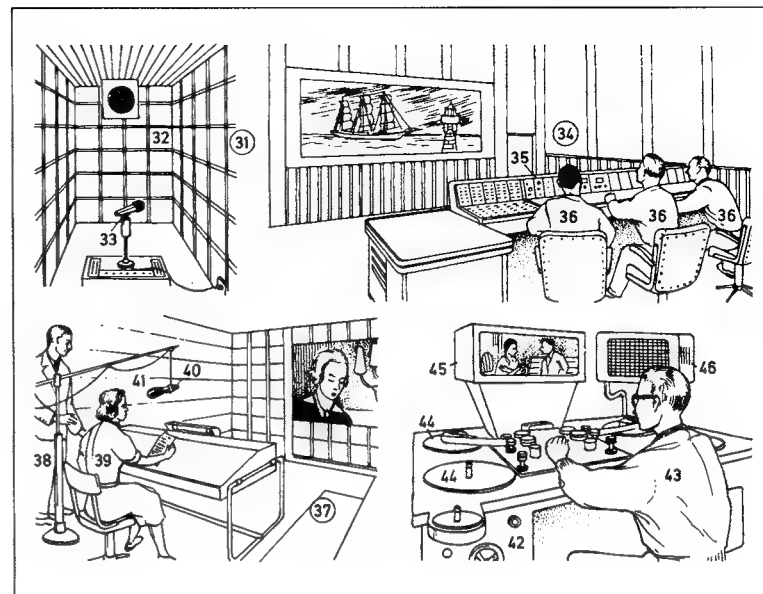

- 31 echo chamber
- 32 echo chamber loudspeaker
- 33 echo chamber microphone
- 34-36 sound mixing (sound dubbing, mixing of several sound tracks)
- 34 mixing room (dubbing room)
- 35 mixing console (mixing desk) for mono or stereo sound
- 36 dubbing mixers (recording engineers, sound recordists) dubbing (mixing)
- 37-41 synchronization (syncing, dubbing, post-synchronization, post-syncing)
- 37 dubbing studio (dubbing theatre, *Am.* theater)
- 38 dubbing director
- 39 dubbing speaker (dubbing actress)
- 40 boom microphone
- 41 microphone cable
- 42-46 cutting (editing)
- 42 cutting table (editing table, cutting bench)
- 43 film editor (cutter)
- 44 film turntables for picture and sound tracks
- 45 projection of the picture
- 46 loudspeaker

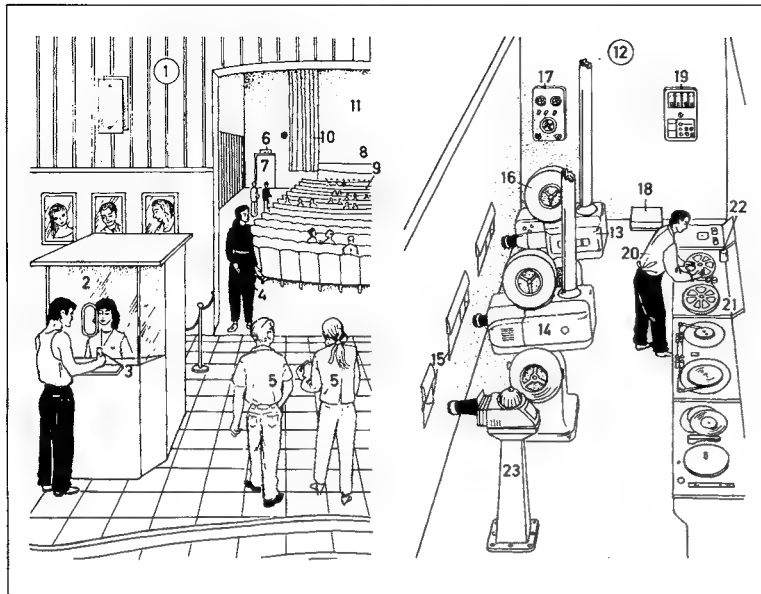

1-23 film projection (motion picture projection)

- 1 cinema (picture house, *Am.* movie theater, movie house)
 2 cinema box office (*Am.* movie theater box office)
 3 cinema ticket (*Am.* movie theater ticket)
 4 usherette
 5 cinemagoers (filmgoers, cinema audience, *Am.* moviegoers, movie audience)
 6 safety lighting (emergency lighting)
 7 emergency exit
 8 stage
 9 rows of seats (rows)
 10 stage curtain (screen curtain)
 11 screen (projection screen)
 12 projection room (projection booth)
 13 lefthand projector
 14 righthand projector
 15 projection room window with projection window and observation port

- 16 reel drum (spool box)
 17 house light dimmers (auditorium lighting control)
 18 rectifier, a selenium or mercury vapour rectifier for the projection lamps
 19 amplifier
 20 projectionist
 21 rewind bench for rewinding the film
 22 film cement (splicing cement)
 23 slide projector for advertisements
- 24-52 film projectors**
 24 sound projector (film projector, cinema projector, theatre projector, *Am.* movie projector)
 25-38 projector mechanism
 25 fireproof reel drums (spool boxes) with circulating oil cooling system
 26 feed sprocket (supply sprocket)
 27 take-up sprocket
 28 magnetic head cluster
 29 guide roller (guiding roller) with framing control

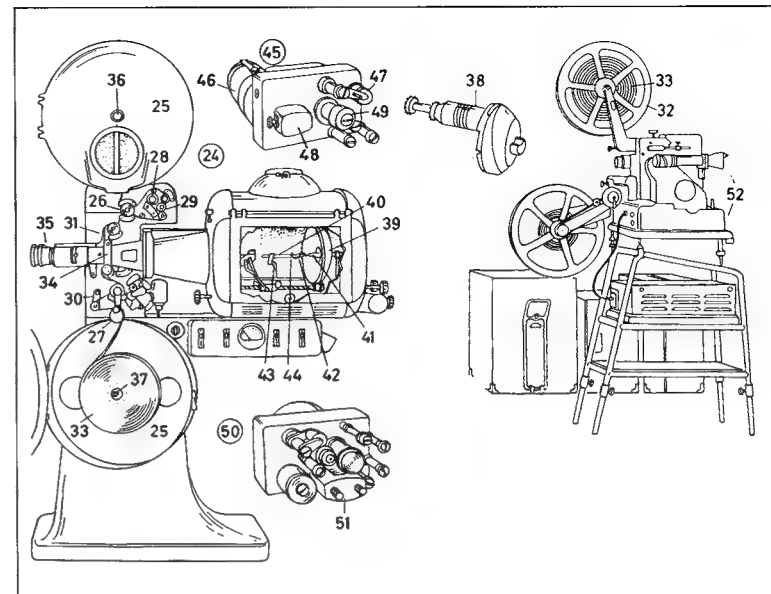

- 30 loop former for smoothing out the intermittent movement; *also*: film break detector
 31 film path
 32 film reel (film spool)
 33 reel of film
 34 film gate (picture gate, projector gate) with cooling fan
 35 projection lens (projector lens)
 36 feed spindle
 37 take-up spindle with friction drive
 38 maltese cross mechanism (maltese cross movement, Geneva movement)
 39-44 lamphouse
 39 mirror arc lamp, with aspherical (non-spherical) concave mirror and blowout magnet for stabilizing the arc (*also*: high-pressure xenon arc lamp)
 40 positive carbon (positive carbon rod)

- 41 negative carbon (negative carbon rod)
 42 arc
 43 carbon rod holder
 44 crater (carbon crater)
 45 optical sound unit [also designed for multi-channel optical stereophonic sound and for push-pull sound tracks]
 46 sound optics
 47 sound head
 48 exciter lamp in housing
 49 photocell in hollow drum
 50 attachable four-track magnetic sound unit (penthouse head, magnetic sound head)
 51 four-track magnetic head
 52 narrow-gauge (*Am.* narrow-gage) cinema projector for mobile cinema

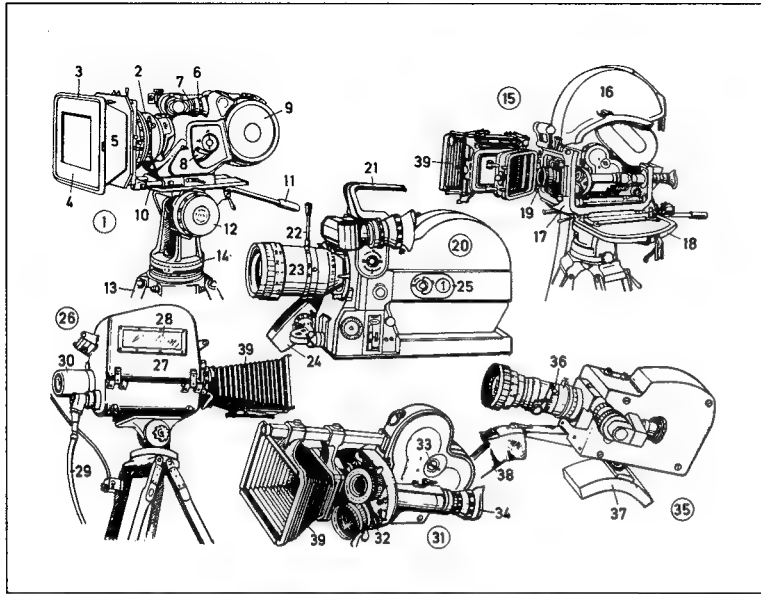

1-39 motion picture cameras (film cameras)

- 1 standard-gauge (*Am.* standard-gage) motion picture camera (standard-gauge, *Am.* standard-gage, 35 mm camera)
 2 lens (object lens, taking lens)
 3 lens hood (sunshade) with matte box
 4 matte (mask)
 5 lens hood barrel
 6 viewfinder eyepiece
 7 eyepiece control ring
 8 opening control for the segment disc (disk) shutter
 9 magazine housing
 10 slide bar for the lens hood
 11 control arm (control lever)
 12 pan and tilt head
 13 wooden tripod
 14 degree scale
 15 soundproof (blimped) motion picture camera (film camera)
 16-18 soundproof housing (blimp)
 16 upper section of the soundproof housing
 17 lower section of the soundproof housing
 18 open sidewall of the soundproof housing
 19 camera lens
 20 lightweight professional motion picture camera
 21 grip (handgrip)
 22 zooming lever
 23 zoom lens (variable focus lens, varifocal lens) with infinitely variable focus
 24 handgrip with shutter release
 25 camera door
 26 sound camera (newsreel camera) for recording sound and picture
 27 soundproof housing (blimp)
 28 window for the frame counters and indicator scales
 29 pilot tone cable (sync pulse cable)
 30 pilot tone generator (signal generator, pulse generator)
 31 professional narrow-gauge (*Am.* narrow-gage) motion picture camera, a 16 mm camera
 32 lens turret (turret head)
 33 housing lock
 34 eyecup
 35 high-speed camera, a special narrow-gauge (*Am.* narrow-gage) camera
 36 zooming lever
 37 rifle grip
 38 handgrip with shutter release
 39 lens hood bellows

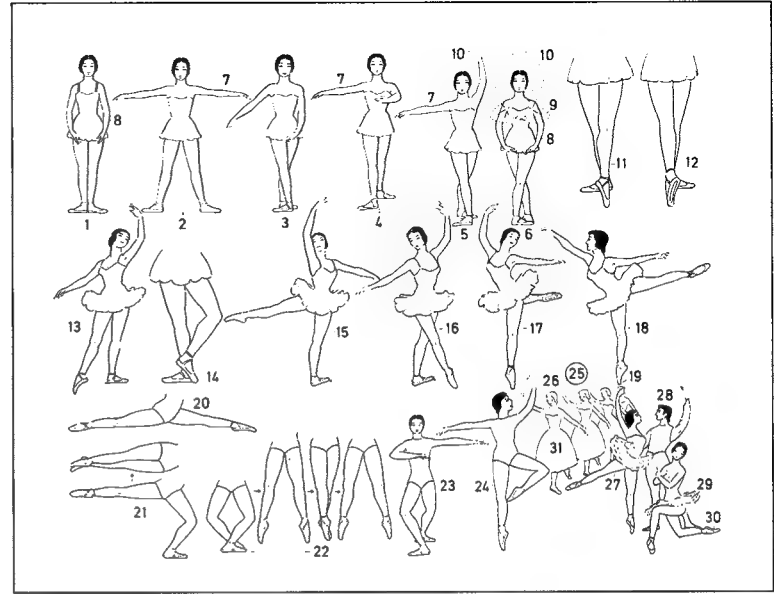

1-6 the five positions (ballet positions)

- 1 first position
 2 second position
 3 third position
 4 fourth position [open]
 5 fourth position [crossed; extended fifth position]
 6 fifth position
 7-10 ports de bras (arm positions)
 7 port de bras à côté
 8 port de bras en bas
 9 port de bras en avant
 10 port de bras en haut
 11 dégagé à la quatrième devant
 12 dégagé à la quatrième derrière
 13 effacé
 14 sur le cou-de-pied
 15 écarté
 16 croisé
 17 attitude
 18 arabesque
 19 à pointe (on full point)
 20 splits
 21 cabriole (capriole)
 22 entrechat (entrechat quatre)
 23 préparation [e.g. for a pirouette]
 24 pirouette
 25 corps de ballet
 26 ballet dancer (ballerina)
 27, 28 pas de trois
 27 prima ballerina
 28 principal male dancer (leading soloist)
 29 tutu
 30 point shoe, a ballet shoe (ballet slipper)
 31 ballet skirt

1-4 types of curtain operation

- 1 draw curtain (side parting)
- 2 tableau curtain (bunching up side-ways)
- 3 fly curtain (vertical ascent)
- 4 combined fly and draw curtain
- 5-11 **cloakroom hall** (Am. checkroom hall)
- 5 cloakroom (Am. checkroom)
- 6 cloakroom attendant (Am. checkroom attendant)
- 7 cloakroom ticket (Am. check)
- 8 playgoer (theatregoer, Am. theatergoer)
- 9 opera glass (opera glasses)
- 10 commissionaire
- 11 theatre (Am. theater) ticket, an admission ticket
- 12, 13 **foyer** (lobby, crush room)
- 12 usher; *form.:* box attendant
- 13 programme (Am. program)
- 14-27 **auditorium and stage**

- 14 stage
- 15 proscenium
- 16-20 **auditorium**
- 16 gallery (balcony)
- 17 upper circle
- 18 dress circle (Am. balcony, mezzanine)
- 19 front stalls
- 20 seat (theatre seat, Am. theater seat)
- 21-27 **rehearsal** (stage rehearsal)
- 21 chorus
- 22, 23 singer
- 24 orchestra pit
- 25 orchestra
- 26 conductor
- 27 baton (conductor's baton)
- 28-42 **paint room**, a workshop
- 28 stagehand (scene shifter)
- 29 catwalk (bridge)
- 30 set piece
- 31 reinforcing struts
- 32 built piece (built unit)
- 33 backcloth (backdrop)
- 34 portable box for paint containers

- 35 scene painter
- 36 paint trolley
- 37 stage designer (set designer)
- 38 costume designer
- 39 design for a costume
- 40 sketch for a costume
- 41 model stage
- 42 model of the set
- 43-52 **dressing room**
- 43 dressing room mirror
- 44 make-up gown
- 45 make-up table
- 46 greasepaint stick
- 47 chief make-up artist (chief make-up man)
- 48 make-up artist (hairstylist)
- 49 wig
- 50 props (properties)
- 51 theatrical costume
- 52 call light

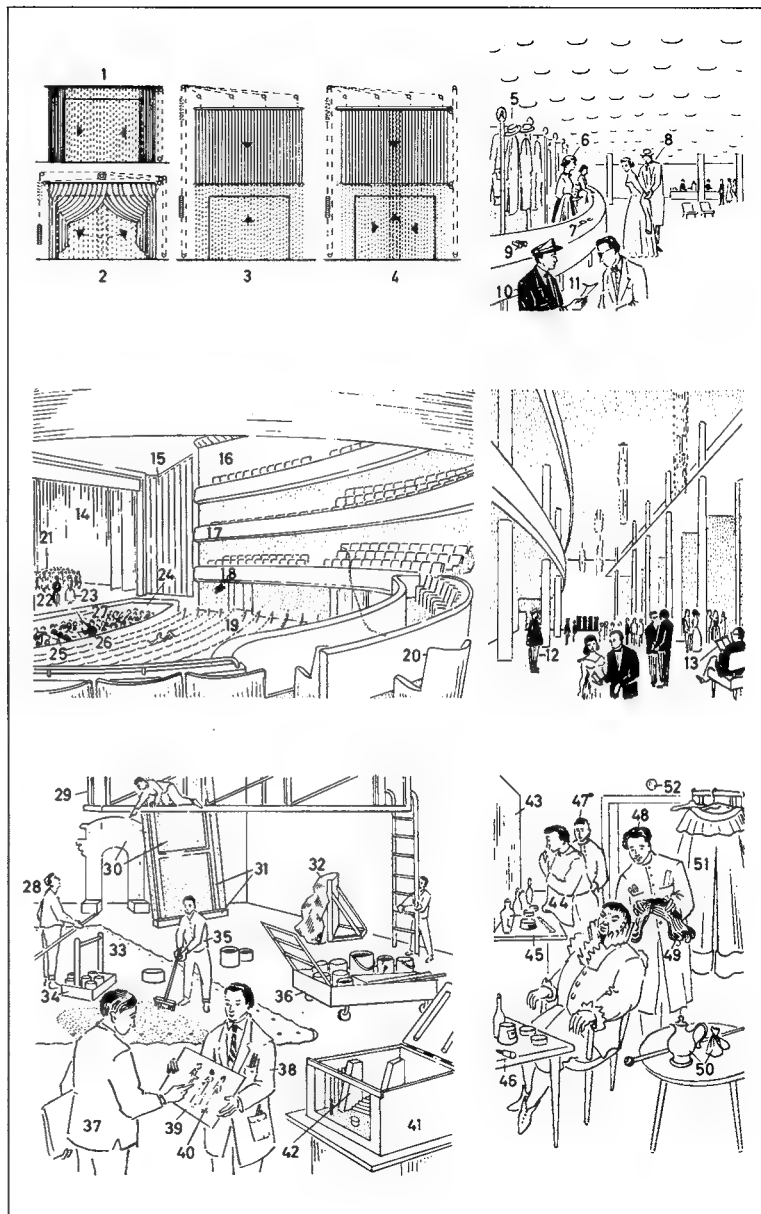

1-60 stagehouse with machinery

(machinery in the flies and below stage)

- 1 control room
- 2 control console (lighting console, lighting control console) with pre-set control for presetting lighting effects
- 3 lighting plot (light plot)
- 4 grid (gridiron)
- 5 fly floor (fly gallery)
- 6 sprinkler system for fire prevention (for fire protection)
- 7 fly man
- 8 fly lines (lines)
- 9 cyclorama
- 10 backcloth (backdrop, background)
- 11 arch, a drop cloth
- 12 border
- 13 compartment (compartment-type, compartmentalized) batten (*Am.* border light)
- 14 stage lighting units (stage lights)
- 15 horizon lights (backdrop lights)
- 16 adjustable acting area lights (acting area spotlights)
- 17 scenery projectors (projectors)
- 18 monitor (water cannon) (piece of safety equipment)
- 19 travelling (*Am.* traveling) lighting bridge (travelling lighting gallery)
- 20 lighting operator (lighting man)
- 21 portal spotlight (tower spotlight)
- 22 adjustable proscenium
- 23 curtain (theatrical curtain)
- 24 iron curtain (safety curtain, fire curtain)
- 25 forestage (apron)
- 26 footlight (footlights, floats)
- 27 prompt box
- 28 prompter
- 29 stage manager's desk
- 30 stage director (stage manager)
- 31 revolving stage
- 32 trap opening
- 33 lift (*Am.* elevator)
- 34 bridge (*Am.* elevator), a rostrum

- 35 pieces of scenery
- 36 scene
- 37 actor
- 38 actress
- 39 extras (supers, supernumeraries)
- 40 director (producer)
- 41 prompt book (prompt script)
- 42 director's table (producer's table)
- 43 assistant director (assistant producer)
- 44 director's script (producer's script)
- 45 stage carpenter
- 46 stagehand (scene shifter)
- 47 set piece
- 48 mirror spot (mirror spotlight)
- 49 automatic filter change (with colour filters, colour mediums, gelatines)
- 50 hydraulic plant room
- 51 water tank
- 52 suction pipe
- 53 hydraulic pump
- 54 pressure pipe
- 55 pressure tank (accumulator)
- 56 pressure gauge (*Am.* gage)
- 57 level indicator (liquid level indicator)
- 58 control lever
- 59 operator
- 60 rams

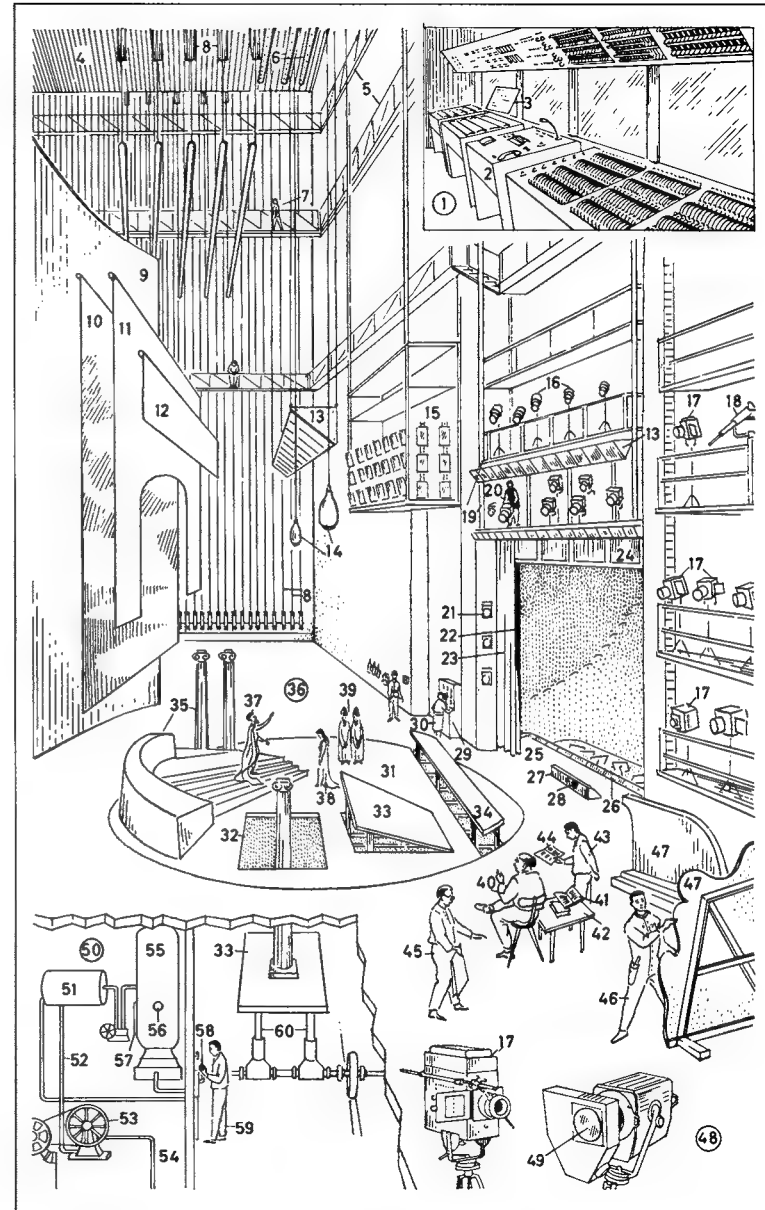

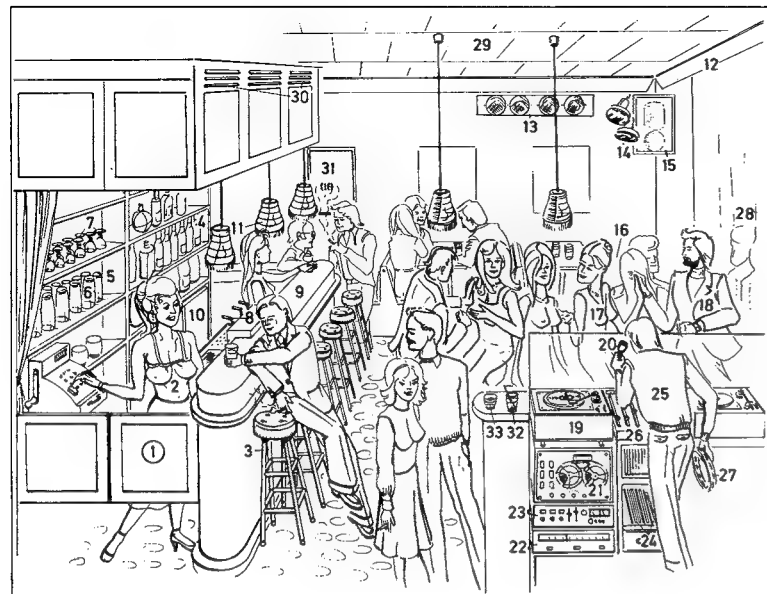

- | | |
|--|--|
| 1 bar | 22 tuner |
| 2 barmaid | 23 amplifier |
| 3 bar stool | 24 records (discs) |
| 4 shelf for bottles | 25 disc jockey |
| 5 shelf for glasses | 26 mixing console (mixing desk, mixer) |
| 6 beer glass | 27 tambourine |
| 7 wine and liqueur glasses | 28 mirrored wall |
| 8 beer tap (tap) | 29 ceiling tiles |
| 9 bar | 30 ventilators |
| 10 refrigerator (fridge, <i>Am.</i> icebox) | 31 toilets (lavatories, WC) |
| 11 bar lamps | 32 long drink |
| 12 indirect lighting | 33 cocktail (<i>Am.</i> highball) |
| 13 colour (<i>Am.</i> color) organ (clavilux) | |
| 14 dance floor lighting | |
| 15 speaker (loudspeaker) | |
| 16 dance floor | |
| 17, 18 dancing couple (dancers) | |
| 19 record player | |
| 20 microphone | |
| 21 tape recorder | |
| 22, 23 stereo system (stereo equipment) | |

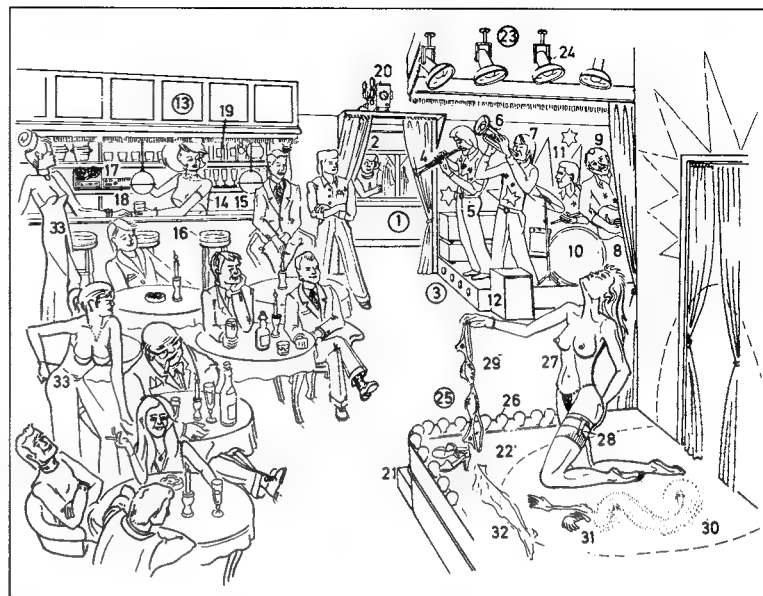

1-33 nightclub (night spot)

- | | |
|--|--|
| 1 cloakroom (<i>Am.</i> checkroom) | 21 box containing screen |
| 2 cloakroom attendant (<i>Am.</i> checkroom attendant) | 22 stage |
| 3 band | 23 stage lighting |
| 4 clarinet | 24 spotlight |
| 5 clarinetist (<i>Am.</i> clarinetist) | 25 festoon lighting |
| 6 trumpet | 26 festoon lamp (lamp, light bulb) |
| 7 trumpeter | 27-32 striptease act (striptease number) |
| 8 guitar | 27 striptease artist (stripper) |
| 9 guitarist (guitar player) | 28 suspender (<i>Am.</i> garter) |
| 10 drums | 29 brassière (bra) |
| 11 drummer | 30 fur stole |
| 12 speaker (loudspeaker) | 31 gloves |
| 13 bar | 32 stocking |
| 14 barmaid | 33 hostess |
| 15 bar | |
| 16 bar stool | |
| 17 tape recorder | |
| 18 receiver | |
| 19 spirits | |
| 20 cine projector for porno films (sex films, blue movies) | |

1-33 bullfight (corrida, corrida de toros)

- 1 mock bullfight
- 2 novice (aspirant matador, novillero)
- 3 mock bull (dummy bull)
- 4 novice banderillero (apprentice banderillero)
- 5 bullring (plaza de toros) [diagram]
- 6 main entrance
- 7 boxes
- 8 stands
- 9 arena (ring)
- 10 bullfighters' entrance
- 11 torril door
- 12 exit gate for killed bulls
- 13 slaughterhouse
- 14 bull pens (corrals)
- 15 paddock
- 16 lancer on horseback (picador)
- 17 lance (pike pole, javelin)
- 18 armoured (*Am.* armored) horse
- 19 leg armour (*Am.* armor)
- 20 picador's round hat
- 21 banderillero, a torero
- 22 banderillas (barbed darts)
- 23 shirtwaist
- 24 bullfight
- 25 matador (swordsman), a torero
- 26 queue, a distinguishing mark of the matador
- 27 red cloak (capa)
- 28 fighting bull
- 29 montera [hat made of tiny black silk chenille balls]
- 30 killing the bull (kill, estocada)
- 31 matador in charity performances [without professional uniform]
- 32 estoque (sword)
- 33 muleta
- 34 rodeo
- 35 young bull
- 36 cowboy
- 37 stetson (stetson hat)
- 38 scarf (necktie)
- 39 rodeo rider
- 40 lasso

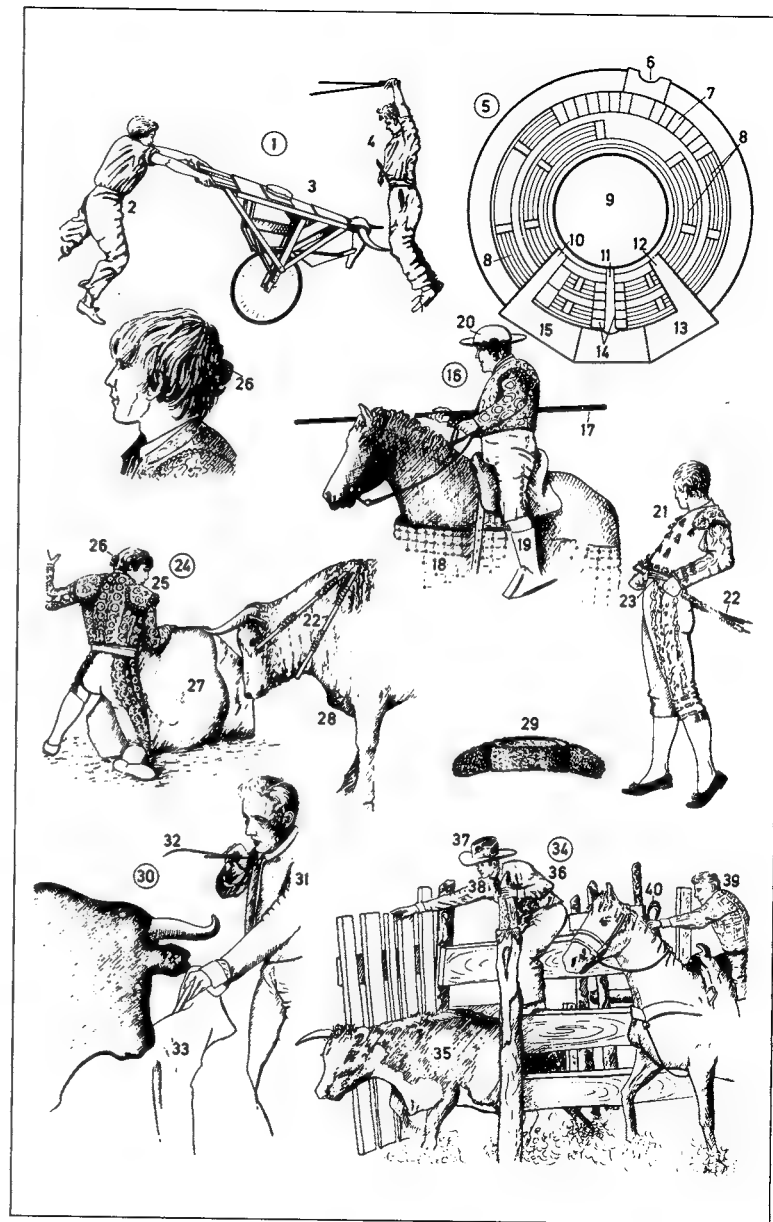

1, 2 medieval (mediaeval) notes

1 plainsong notation (neumes, neums, pneumes, square notation)

2 mensural notation

3-7 musical note (note)

3 note head

4 note stem (note tail)

5 hook

6 stroke

7 dot indicating augmentation of note's value

8-11 clefs

8 treble clef (G-clef, violin clef)

9 bass clef (F-clef)

10 alto clef (C-clef)

11 tenor clef

12-19 note values

12 breve (brevis, *Am.* double-whole note)13 semibreve (*Am.* whole note)14 minim (*Am.* half note)15 crotchet (*Am.* quarter note)16 quaver (*Am.* eighth note)17 semiquaver (*Am.* sixteenth note)18 demisemiquaver (*Am.* thirty-second note)19 hemidemisemiquaver (*Am.* sixty-fourth note)

20-27 rests

20 breve rest

21 semibreve rest (*Am.* whole rest)22 minim rest (*Am.* half rest)23 crotchet rest (*Am.* quarter rest)24 quaver rest (*Am.* eighth rest)25 semiquaver rest (*Am.* sixteenth rest)26 demisemiquaver rest (*Am.* thirty-second rest)27 hemidemisemiquaver rest (*Am.* sixty-fourth rest)28-42 time (time signatures, measure, *Am.* meter)

28 two-eight time

29 two-four time

30 two-two time

31 four-eight time

32 four-four time (common time)

33 four-two time

34 six-eight time

35 six-four time

36 three-eight time

37 three-four time

38 three-two time

39 nine-eight time

40 nine-four time

41 five-four time

42 bar (bar line, measure line)

43, 44 staff (stave)

43 line of the staff

44 space

45-49 scales

45 C major scale naturals: c, d, e, f, g, a, b, c

46 A minor scale [natural] naturals: a, b, c, d, e, f, g, a

47 A minor scale [harmonic]

48 A minor scale [melodic]

49 chromatic scale

50-54 accidentals (inflections, key signatures)

50, 51 signs indicating the raising of a note

50 sharp (raising the note a semitone or half-step)

51 double sharp (raising the note a tone or full-step)

52, 53 signs indicating the lowering of a note

52 flat (lowering the note a semitone or half-step)

53 double flat (lowering the note a tone or full-step)

54 natural

55-68 keys (major keys and the related minor keys having the same signature)

55 C major (A minor)

56 G major (E minor)

57 D major (B minor)

58 A major (F sharp minor)

59 E major (C sharp minor)

60 B major (G sharp minor)

61 F sharp major (D sharp minor)

62 C major (A minor)

63 F major (D minor)

64 B flat major (G minor)

65 E flat major (C minor)

66 A flat major (F minor)

67 D flat major (B flat minor)

68 G flat major (E flat minor)

Magni - fi - cat

Nu kom der heidē Heiland,

1 2 3 7 42 44 28 29 45 46 47 48 49 50 51 52 53 54 55 56 57 58 59 60 61 62 63 64 65 66 67 68

- 1-5 chord
- 1-4 triad
- 1 major triad
- 2 minor triad
- 3 diminished triad
- 4 augmented triad
- 5 chord of four notes, a chord of the seventh (seventh chord, dominant seventh chord)
- 6-13 intervals
- 6 unison (unison interval)
- 7 major second
- 8 major third
- 9 perfect fourth
- 10 perfect fifth
- 11 major sixth
- 12 major seventh
- 13 perfect octave
- 14-22 ornaments (graces, grace notes)
- 14 long appoggiatura
- 15 acciaccatura (short appoggiatura)
- 16 slide
- 17 trill (shake) without turn
- 18 trill (shake) with turn
- 19 upper mordent (inverted mordent, pralltriller)
- 20 lower mordent (mordent)
- 21 turn
- 22 arpeggio
- 23-26 other signs in musical notation
- 23 triplet; *corresponding groupings*: duplet (couplet), quadruplet, quintuplet, sextolet (sextuplet), septolet (septuplet, septimole)
- 24 tie (bind)
- 25 pause (pause sign)
- 26 repeat mark
- 27-41 expression marks (signs of relative intensity)
- 27 marcato (marcato, markiert, attack, strong accent)
- 28 presto (quick, fast)
- 29 portato (lourer, mezzo staccato, carried)
- 30 tenuto (held)
- 31 crescendo (increasing gradually in power)

- 32 decrescendo (diminuendo, decreasing or diminishing gradually in power)
- 33 legato (bound)
- 34 staccato (detached)
- 35 piano (soft)
- 36 pianissimo (very soft)
- 37 pianissimo piano (as soft as possible)
- 38 forte (loud)
- 39 fortissimo (very loud)
- 40 forte fortissimo (double fortissimo, as loud as possible)
- 41 forte piano (loud and immediately soft again)
- 42-50 divisions of the compass
- 42 subcontra octave (double contra octave)
- 43 contra octave
- 44 great octave
- 45 small octave
- 46 one-line octave
- 47 two-line octave
- 48 three-line octave
- 49 four-line octave
- 50 five-line octave

1 2 3 4 5 6 7 8 9 10 11 12 13

14 15 16 17 18 19 20 21

22 23 24 25 26

28 Presto

29 30 31 32 33 34

p *pp* *ppp* *f* *ff* *fff* *fp*

35 36 37 38 39 40 41

42 43 44 45 46 47 48 49 50

sva sopra

sva bassa

${}_2A {}_2B {}_2H {}_2C$ usw. ; $H C H c h c^1 h^1 c^2 h^2 c^3 h^3 c^4 h^4 c^5$
 in Britain:
 $A_2 B_2 C_2 C_1$ etc. $B_1 C B c b c' b^1 c^1 b^2 c^2 b^3 c^3 b^4 c^4 b^5 c^5$

- 1 lur, a bronze trumpet
- 2 panpipes (Pandean pipes, syrinx)
- 3 aulos, a double shawm
- 4 aulos pipe
- 5 phorbeia (peristomion, capistrum, mouth band)
- 6 crumhorn (crumhorn, cromorne, krumhorn, krummhorn)
- 7 recorder (fipple flute)
- 8 bagpipe; *sim.*: musette
- 9 bag
- 10 chanter (melody pipe)
- 11 drone (drone pipe)
- 12 curved cornett (zink)
- 13 serpent
- 14 shawm (schalmeyes); *larger*: bombard (bombarde, pommcr)
- 15 cythara (cithara); *sim. and smaller*: lyre
- 16 arm
- 17 bridge
- 18 sound box (resonating chamber, resonator)
- 19 plectrum, a plucking device
- 20 kit (pochette), a miniature violin
- 21 cittern (cithern, cither, cister, citole), a plucked instrument; *sim.*: pandora (bandora, bandore)
- 22 sound hole
- 23 viol (descant viol, treble viol, a viola da gamba); *larger*: tenor viol, bass viol (viola da gamba, gamba), violone (double bass viol)
- 24 viol bow
- 25 hurdy-gurdy (vielle à roue, symphonia, armonie, organistrum)
- 26 friction wheel
- 27 wheel cover (wheel guard)
- 28 keyboard (keys)
- 29 resonating body (resonator, sound box)
- 30 melody strings
- 31 drone strings (drones, bourdons)
- 32 dulcimer
- 33 rib (resonator wall)
- 34 beater for the Valasian dulcimer

- 35 hammer (stick) for the Appenzell dulcimer
- 36 clavichord; *kinds*: fretted or unfretted clavichord
- 37 clavichord mechanism
- 38 key (key lever)
- 39 balance rail
- 40 guiding blade
- 41 guiding slot
- 42 resting rail
- 43 tangent
- 44 string
- 45 harpsichord (clavicembalo, cembalo), a wing-shaped stringed keyboard instrument; *sim.*: spinet (virginal)
- 46 upper keyboard (upper manual)
- 47 lower keyboard (lower manual)
- 48 harpsichord mechanism
- 49 key (key lever)
- 50 jack
- 51 slide (register)
- 52 tongue
- 53 quill plectrum
- 54 damper
- 55 string
- 56 portable organ, a portable organ; *larger*: positive organ (positive)
- 57 pipe (flue pipe)
- 58 bellows

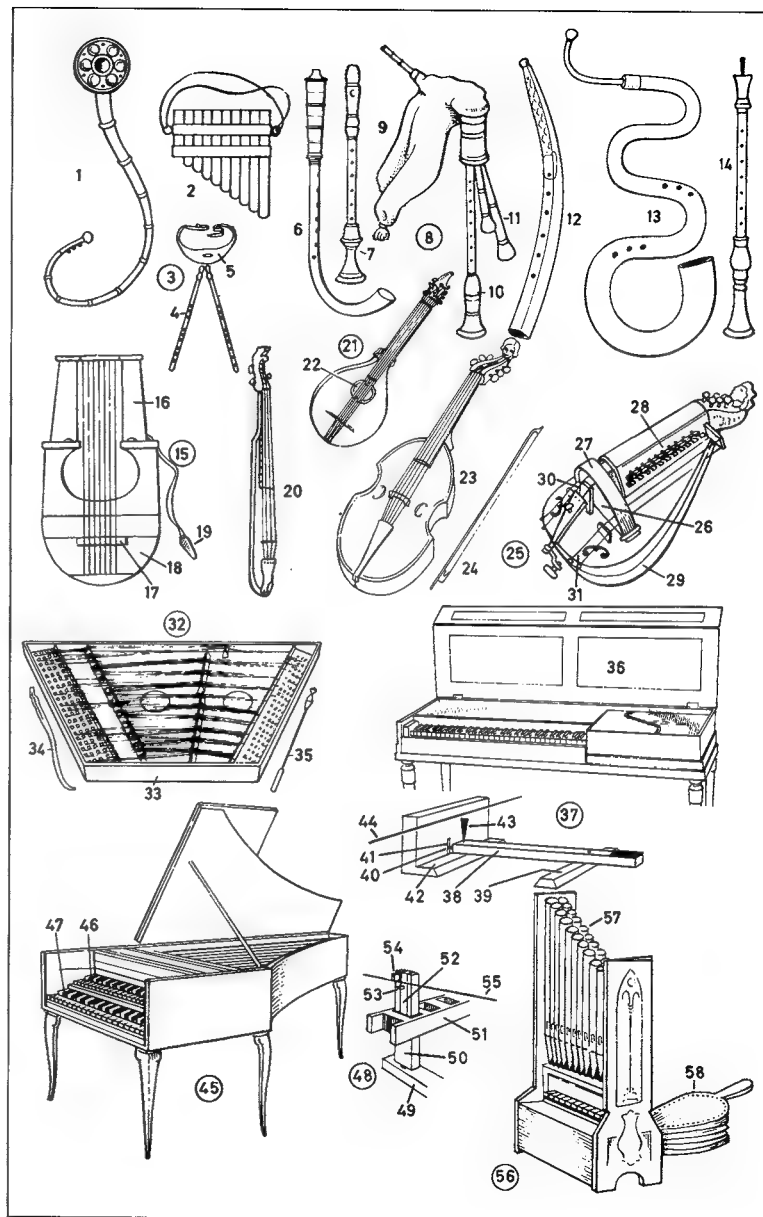

1-62 orchestral instruments

1-27 stringed instruments, bowed instruments

- 1 violin
2 neck of the violin
3 resonating body (violin body, sound box of the violin)
4 rib (side wall)
5 violin bridge
6 F-hole, a sound hole
7 tailpiece
8 chin rest
9 strings (violin strings, fiddle strings): G-string, D-string, A-string, E-string
10 mute (sordino)
11 resin (rosin, colophony)
12 violin bow (bow)
13 nut (frog)
14 stick (bow stick)
15 hair of the violin bow (horsehair)
16 violoncello (cello), a member of the da gamba violin family
17 scroll
18 tuning peg (peg)
19 pegbox
20 nut
21 fingerboard
22 spike (tailpin)
23 double bass (contrabass, violone, double bass viol, *Am.* bass)
24 belly (top, soundboard)
25 rib (side wall)
26 purfling (inlay)
27 viola
28-38 woodwind instruments (woodwinds)
28 bassoon; *larger*: double bassoon (contrabassoon)
29 tube with double reed
30 piccolo (small flute, piccolo flute, flauto piccolo)
31 flute (German flute), a cross flute (transverse flute, side-blown flute)
32 key
33 fingerhole
34 clarinet; *larger*: bass clarinet

- 35 key (brille)
36 mouthpiece
37 bell
38 oboe (hautboy); *kinds*: oboe d'amore; tenor oboes: oboe da caccia, cor anglais; heckelphone (baritone oboe)
39-48 brass instruments (brass)
39 tenor horn
40 valve
41 French horn (horn, waldhorn), a valve horn
42 bell
43 trumpet; *larger*: Bb cornet; *smaller*: cornet
44 bass tuba (tuba, bombardon); *sim.*: helicon (pellitone), contrabass tuba
45 thumb hold
46 trombone; *kinds*: alto trombone, tenor trombone, bass trombone
47 trombone slide (slide)
48 bell
49-59 percussion instruments
49 triangle
50 cymbals
51-59 membranophones
51 side drum (snare drum)
52 drum head (head, upper head, batter head, vellum)
53 tensioning screw
54 drumstick
55 bass drum (Turkish drum)
56 stick (padded stick)
57 kettledrum (timpano), a screw-tensioned drum; *sim.*: machine drum (mechanically tuned drum)
58 kettledrum skin (kettledrum vellum)
59 tuning screw
60 harp, a pedal harp
61 strings
62 pedal

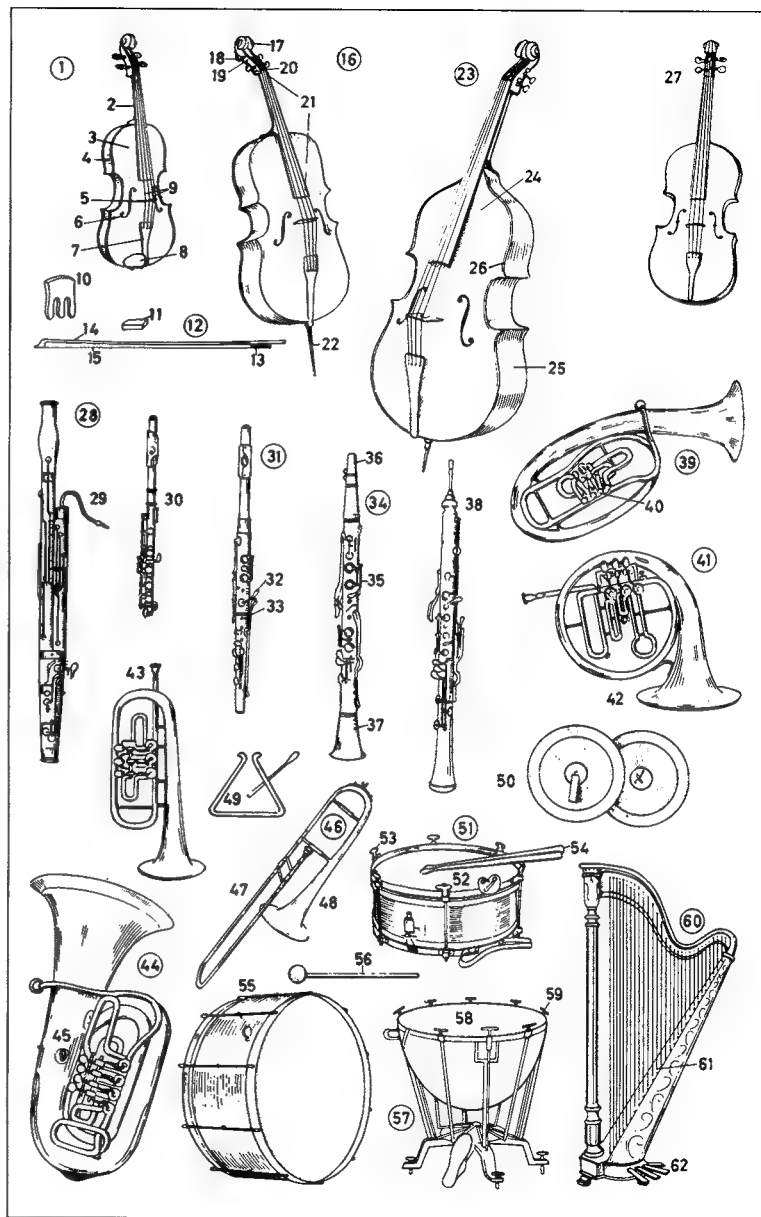

1-46 popular musical instruments (folk instruments)

1-31 stringed instruments

- 1 lute; *larger*: theorbo, chitarrone
 2 resonating body (resonator)
 3 soundboard (belly, table)
 4 string fastener (string holder)
 5 sound hole (rose)
 6 string, a gut (catgut) string
 7 neck
 8 fingerboard
 9 fret
 10 head (bent-back pegbox, swan-head pegbox, pegbox)
 11 tuning peg (peg, lute pin)
 12 guitar
 13 string holder
 14 string, a gut (catgut) or nylon string
 15 resonating body (resonating chamber, resonator, sound box)
 16 mandolin (mandoline)
 17 sleeve protector (cuff protector)
 18 neck
 19 pegdisc
 20 plectrum
 21 zither (plucked zither)
 22 pin block (wrest pin block, wrest plank)
 23 tuning pin (wrest pin)
 24 accompaniment strings (bass strings, unfretted strings, open strings)
 25 melody strings (fretted strings, stopped strings)
 26 semicircular projection of the resonating sound box (resonating body)
 27 ring plectrum
 28 balalaika
 29 banjo
 30 tambourine-like body
 31 parchment membrane
 32 ocarina, a globular flute
 33 mouthpiece
 34 fingerhole
 35 mouth organ (harmonica)
 36 accordion; *sim.*: piano accordion, concertina, bandoneon
 37 bellows
 38 bellows strap

- 39 melody side (keyboard side, melody keys)
 40 keyboard (keys)
 41 treble stop (treble coupler, treble register)
 42 stop lever
 43 bass side (accompaniment side, bass studs, bass press-studs, bass buttons)
 44 bass stop (bass coupler, bass register)
 45 tambourine
 46 castanets
 47-78 jazz band instruments (dance band instruments)
 47-58 percussion instruments
 47-54 drum kit (drum set, drums)
 47 bass drum
 48 small tom-tom
 49 large tom-tom
 50 high-hat cymbals (choke cymbals, Charleston cymbals, cup cymbals)
 51 cymbal
 52 cymbal stand (cymbal holder)
 53 wire brush
 54 pedal mechanism
 55 conga drum (conga)
 56 tension hoop
 57 timbales
 58 bongo drums (bongos)
 59 maracas; *sim.*: shakers
 60 guiro
 61 xylophone; *form.*: straw fiddle; *sim.*: marimbaphone (steel marimba), tubaphone
 62 wooden slab
 63 resonating chamber (sound box)
 64 beater
 65 jazz trumpet
 66 valve
 67 finger hook
 68 mute (sordino)
 69 saxophone
 70 bell
 71 crook
 72 mouthpiece
 73 struck guitar (jazz guitar)
 74 hollow to facilitate fingering
 75 vibraphone (*Am.* vibraharp)
 76 metal frame
 77 metal bar
 78 tubular metal resonator

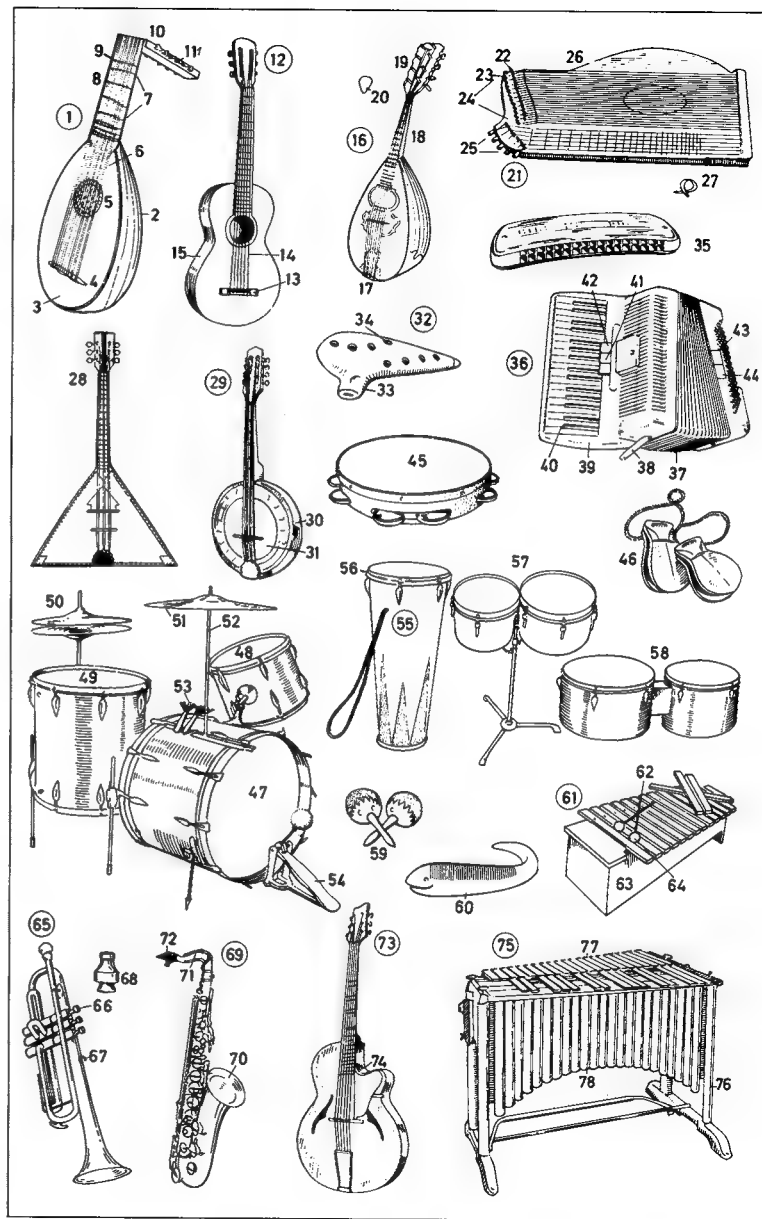

- 1 piano (pianoforte, upright piano, upright, vertical piano, spinet piano, console piano), a keyboard instrument (keyed instrument); *smaller form:* cottage piano (piano); *earlier forms:* pantaleon; celesta, with steel bars instead of strings
- 2-18 piano action (piano mechanism)
- 2 iron frame
- 3 hammer; *collectively:* striking mechanism
- 4, 5 keyboard (piano keys)
- 4 white key (ivory key)
- 5 black key (ebony key)
- 6 piano case
- 7 strings (piano strings)
- 8, 9 piano pedals
- 8 right pedal (sustaining pedal, damper pedal; *loosely:* forte pedal, loud pedal) for raising the dampers
- 9 left pedal (soft pedal; *loosely:* piano pedal) for reducing the striking distance of the hammers on the strings
- 10 treble strings
- 11 treble bridge (treble belly bridge)
- 12 bass strings
- 13 bass bridge (bass belly bridge)
- 14 hitch pin
- 15 hammer rail
- 16 brace
- 17 tuning pin (wrest pin, tuning peg)
- 18 pin block (wrest pin block, wrest plank)
- 19 metronome
- 20 tuning hammer (tuning key, wrest)
- 21 tuning wedge
- 22-39 key action (key mechanism)
- 22 beam
- 23 damper-lifting lever
- 24 felt-covered hammer head
- 25 hammer shank
- 26 hammer rail
- 27 check (back check)
- 28 check felt (back check felt)

- 29 wire stem of the check (wire stem of the back check)
- 30 sticker (hopper, hammer jack, hammer lever)
- 31 button
- 32 action lever
- 33 pilot
- 34 pilot wire
- 35 tape wire
- 36 tape
- 37 damper (damper block)
- 38 damper lifter
- 39 damper rest rail
- 40 grand piano (horizontal piano, grand, concert grand; *smaller:* baby grand piano, boudoir piano; *sim.:* square piano, table piano)
- 41 grand piano pedals; right pedal for raising the dampers; left pedal for softening the tone (shifting the keyboard so that only one string is struck 'una corda')
- 42 pedal bracket
- 43 harmonium (reed organ, melodium)
- 44 draw stop (stop, stop knob)
- 45 knee lever (knee swell, swell)
- 46 pedal (bellows pedal)
- 47 harmonium case
- 48 harmonium keyboard (manual)

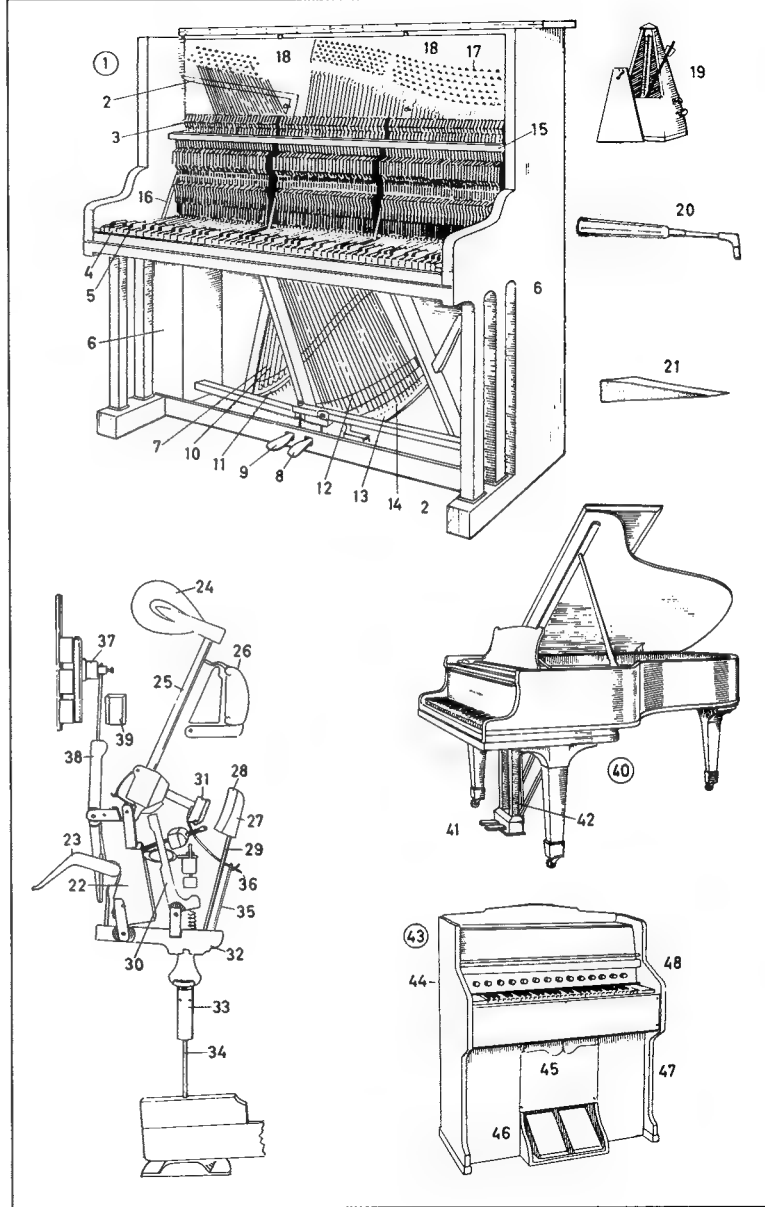

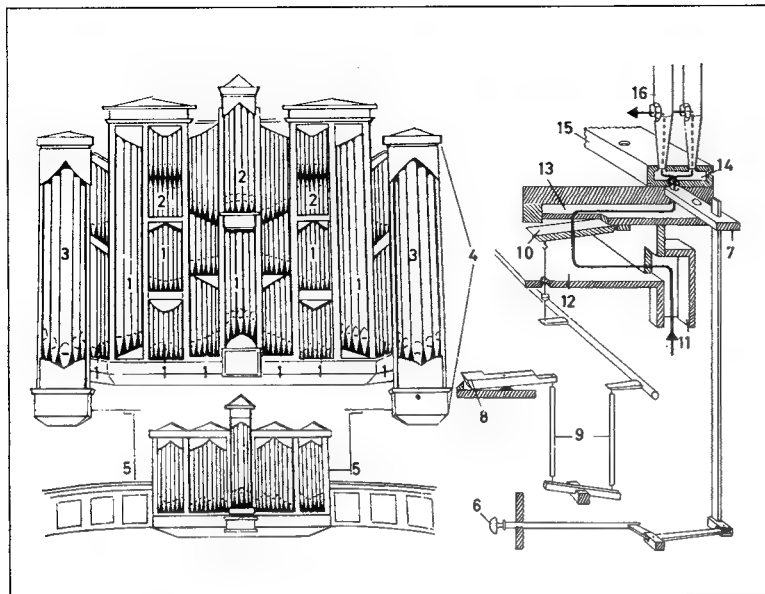

- 1-52 organ** (church organ)
1-5 front view of organ (organ case)
 [built according to classical principles]
1-3 display pipes (face pipes)
1 Hauptwerk
2 Oberwerk
3 pedal pipes
4 pedal tower
5 Rückpositiv
6-16 tracker action (mechanical action); *other systems*: pneumatic action, electric action
6 draw stop (stop, stop knob)
7 slider (slide)
8 key (key lever)
9 sticker
10 pallet
11 wind trunk
12-14 wind chest, a slider wind chest; *other types*: sliderless wind chest (unit wind chest), spring chest, kegellade chest (cone chest), diaphragm chest
12 wind chest (wind chest box)
13 groove
14 upper board groove
15 upper board
16 pipe of a particular stop
17-35 organ pipes (pipes)
17-22 metal reed pipe (*set of pipes*: reed stop), a posaune stop
17 boot
18 shallot
19 tongue
20 block
21 tuning wire (tuning crook)
22 tube
23-30 open metal flue pipe, a salicional
23 foot

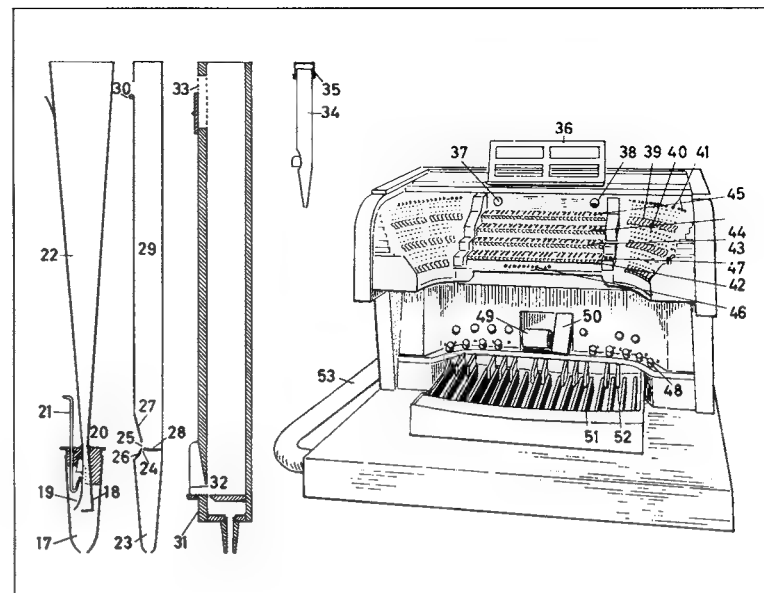

- 24** flue pipe windway (flue pipe duct)
25 mouth (cutup)
26 lower lip
27 upper lip
28 languid
29 body of the pipe (pipe)
30 tuning flap (tuning tongue), a tuning device
31-33 open wooden flue pipe (open wood), principal (diapason)
31 cap
32 ear
33 tuning hole (tuning slot), with slide
34 stopped flue pipe
35 stopper
36-52 organ console (console) of an electric action organ
36 music rest (music stand)
37 crescendo roller indicator
38 voltmeter
39 stop tab (rocker)
40 free combination stud (free combination knob)
41 cancel buttons for reeds, couplers etc.
42 manual I, for the Rückpositiv
43 manual II, for the Hauptwerk
44 manual III, for the Oberwerk
45 manual IV, for the Schwellwerk
46 thumb pistons controlling the manual stops (free or fixed combinations) and buttons for setting the combinations
47 switches for current to blower and action
48 toe piston, for the coupler
49 crescendo roller (general crescendo roller)
50 balanced swell pedal
51 pedal key [natural]
52 pedal key [sharp or flat]
53 cable (transmission cable)

- 1-61 fabulous creatures** (fabulous animals), mythical creatures
- 1 dragon
 - 2 serpent's body
 - 3 claws (claw)
 - 4 bat's wing
 - 5 fork-tongued mouth
 - 6 forked tongue
 - 7 unicorn [symbol of virginity]
 - 8 spirally twisted horn
 - 9 Phoenix
 - 10 flames or ashes of resurrection
 - 11 griffin (griffon, gryphon)
 - 12 eagle's head
 - 13 griffin's claws
 - 14 lion's body
 - 15 wing
 - 16 chimera (chimaera), a monster
 - 17 lion's head
 - 18 goat's head
 - 19 dragon's body
 - 20 sphinx, a symbolic figure
 - 21 human head
 - 22 lion's body
 - 23 mermaid (nix, nixie, water nixie, sea maid, sea maiden, naiad, water nymph, water elf, ocean nymph, sea nymph, river nymph); *sim.*: Nereids, Oceanids (sea divinities, sea deities, sea goddesses); *male*: nix (merman, seaman)
 - 24 woman's trunk
 - 25 fish's tail (dolphin's tail)
 - 26 Pegasus (favourite, *Am.* favorite, steed of the Muses, winged horse); *sim.*: hippogryph
 - 27 horse's body
 - 28 wings
 - 29 Cerberus (hellhound)
 - 30 three-headed dog's body
 - 31 serpent's tail
 - 32 Lernaean (Lernean) Hydra
 - 33 nine-headed serpent's body
 - 34 basilisk (cockatrice)
 - 35 cock's head
 - 36 dragon's body

- 37 giant (titan)
- 38 rock
- 39 serpent's foot
- 40 triton, a merman (demigod of the sea)
- 41 conch shell trumpet
- 42 horse's hoof
- 43 fish's tail
- 44 hippocampus
- 45 horse's trunk
- 46 fish's tail
- 47 sea ox, a sea monster
- 48 monster's body
- 49 fish's tail
- 50 seven-headed dragon of St. John's Revelation (Revelations, Apocalypse)
- 51 wing
- 52 centaur (hippocentaur), half man and half beast
- 53 man's body with bow and arrow
- 54 horse's body
- 55 harpy, a winged monster
- 56 woman's head
- 57 bird's body
- 58 siren, a daemon
- 59 woman's body
- 60 wing
- 61 bird's claw

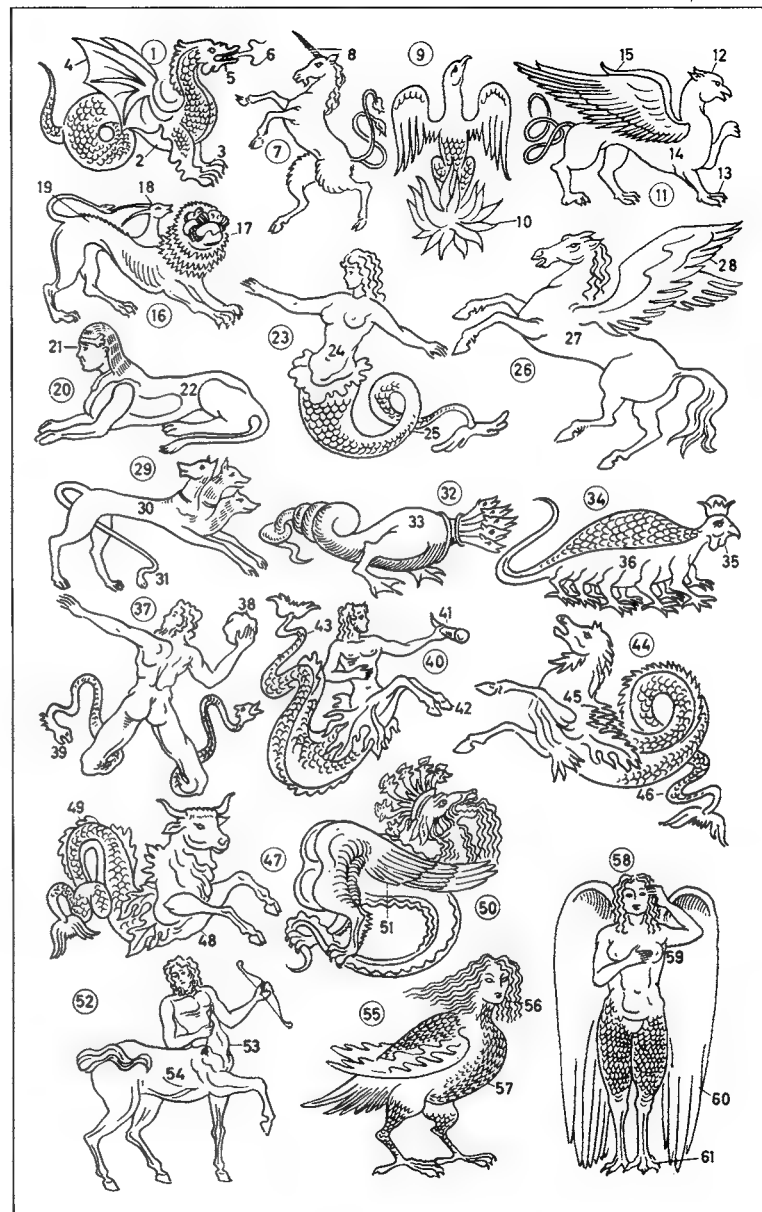

1-40 prehistoric finds

1-9 **Old Stone Age** (Palaeolithic, Paleolithic, period) and **Mesolithic period**

- 1 hand axe (*Am. ax*) (fist hatchet), a stone tool
 2 head of throwing spear, made of bone
 3 bone harpoon
 4 head
 5 harpoon thrower, made of reindeer antler
 6 painted pebble
 7 head of a wild horse, a carving
 8 Stone Age idol, an ivory statuette
 9 bison, a cave painting (rock painting) [cave art, cave painting]

10-20 **New Stone Age** (Neolithic period)

- 10 amphora [corded ware]
 11 bowl [menhir group]
 12 collared flask [Funnel-Beaker culture]
 13 vessel with spiral pattern [spiral design pottery]
 14 bell beaker [bell beaker culture]
 15 pile dwelling (lake dwelling, lacustrine dwelling)
 16 dolmen (cromlech), a megalithic tomb (*coll.*: giant's tomb); *other kinds*: passage grave, gallery grave (long cist); *when covered with earth*: tumulus (barrow, mound)
 17 stone cist, a contracted burial
 18 menhir (standing stone), a monolith

- 19 boat axe (*Am. ax*), a stone battle axe
 20 clay figurine, an idol

21-40 **Bronze Age and Iron Age**; *epochs*: Hallstatt period, La Tène period

- 21 bronze spear head
 22 hafted bronze dagger
 23 socketed axe (*Am. ax*), a bronze axe with haft fastened to rings
 24 girdle clasp
 25 necklace (lunula)
 26 gold neck ring

- 27 violin-bow fibula (safety pin)
 28 serpentine fibula; *other kinds*: boat fibula, arc fibula
 29 bulb-head pin, a bronze pin
 30 two-piece spiral fibula; *sim.*: disc (disk) fibula
 31 hafted bronze knife
 32 iron key
 33 ploughshare (*Am. plowshare*)
 34 sheet-bronze situla, a funerary vessel
 35 pitcher [chip-carved pottery]
 36 miniature ritual cart (miniature ritual chariot)
 37 Celtic silver coin
 38 face urn, a cinerary urn; *other kinds*: domestic urn, embossed urn
 39 urn grave in stone chamber
 40 urn with cylindrical neck

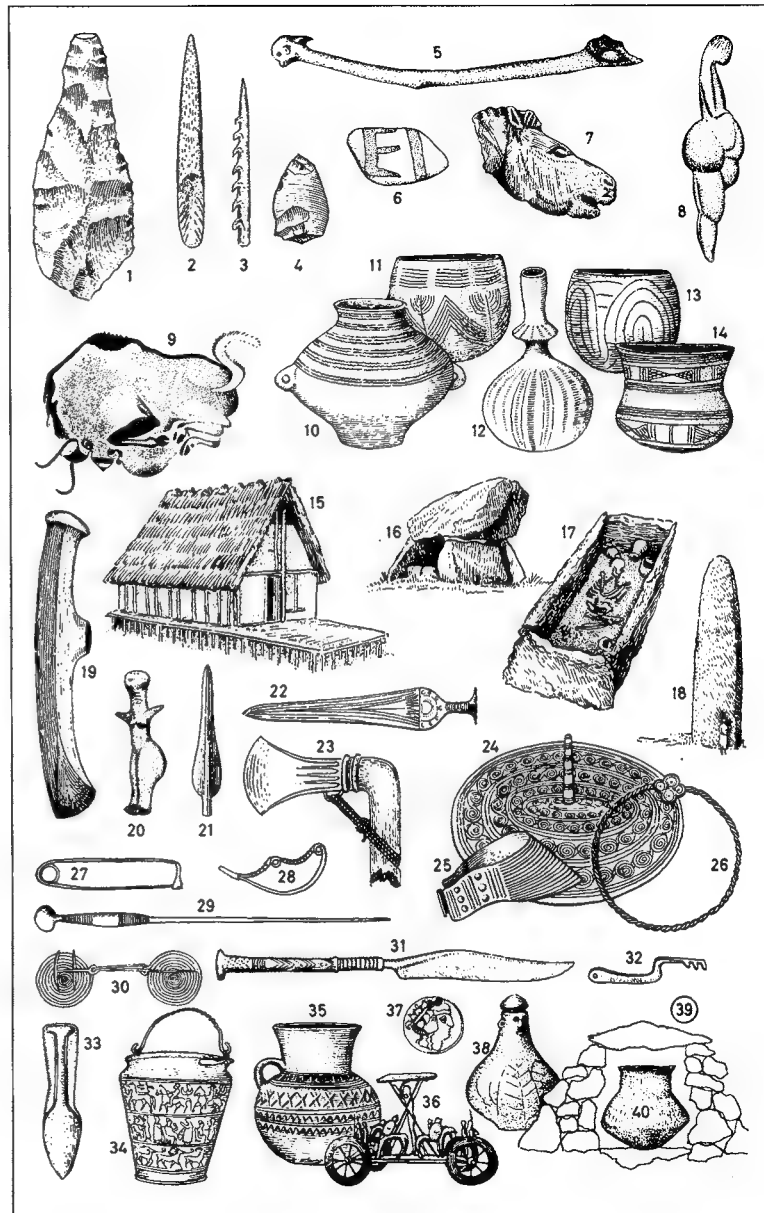

- 1 knight's castle (castle)
 2 inner ward (inner bailey)
 3 draw well
 4 keep (donjon)
 5 dungeon
 6 battlements (crenellation)
 7 merlon
 8 tower platform
 9 watchman
 10 ladies' apartments (bowers)
 11 dormer window (dormer)
 12 balcony
 13 storehouse (magazine)
 14 angle tower
 15 curtain wall (curtains, enclosure wall)
 16 bastion
 17 angle tower
 18 crenel (embrasure)
 19 inner wall
 20 battlemented parapet
 21 parapet (breastwork)
 22 gatehouse
 23 machicolation (machicoulis)
 24 portcullis
 25 drawbridge
 26 buttress
 27 offices and service rooms
 28 turret
 29 chapel
 30 great hall
 31 outer ward (outer bailey)
 32 castle gate
 33 moat (ditch)
 34 approach
 35 watchtower (turret)
 36 palisade (pallisade, palisading)
 37 moat (ditch, fosse)
 38-65 knight's armour (*Am. armor*)
 38 suit of armour (*Am. armor*)
 39-42 helmet
 39 skull
 40 visor (visor)
 41 beaver
 42 throat piece
 43 gorget
 44 épaulière
 45 pallette (pauldron, besageur)
 46 breastplate (cuirass)

- 47 brassard (rear brace and vambrace)
 48 cubitière (coudière, couter)
 49 tasse (tasset)
 50 gauntlet
 51 habergeon (haubergeon)
 52 cuisse (cuish, cuissard, cuissart)
 53 knee cap (knee piece, genouillère, poleyn)
 54 jambeau (greave)
 55 solleret (sabaton, sabbaton)
 56 pavis (pavise, pavais)
 57 buckler (round shield)
 58 boss (umbo)
 59 iron hat
 60 morion
 61 light casque
 62 types of mail and armour (*Am. armor*)
 63 mail (chain mail, chain armour, *Am. armor*)
 64 scale armour (*Am. armor*)
 65 plate armour (*Am. armor*)
 66 accolade (dubbing, knighting)
 67 liege lord, a knight
 68 esquire
 69 cup bearer
 70 minstrel (minnesinger, troubadour)
 71 tournament (tourney, joust, just, tilt)
 72 crusader
 73 Knight Templar
 74 caparison (trappings)
 75 herald (marshal at tournament)
 76 tilting armour (*Am. armor*)
 77 tilting helmet (jousting helmet)
 78 panache (plume of feathers)
 79 tilting target (tilting shield)
 80 lance rest
 81 tilting lance (lance)
 82 vamplate
 83-88 horse armour (*Am. armor*)
 83 neck guard (neck piece)
 84 chamfron (chaffron, chaftron, chamfrain, chanfron)
 85 poitreil
 86 flanchard (flancard)
 87 tournament saddle
 88 rump piece (quarter piece)

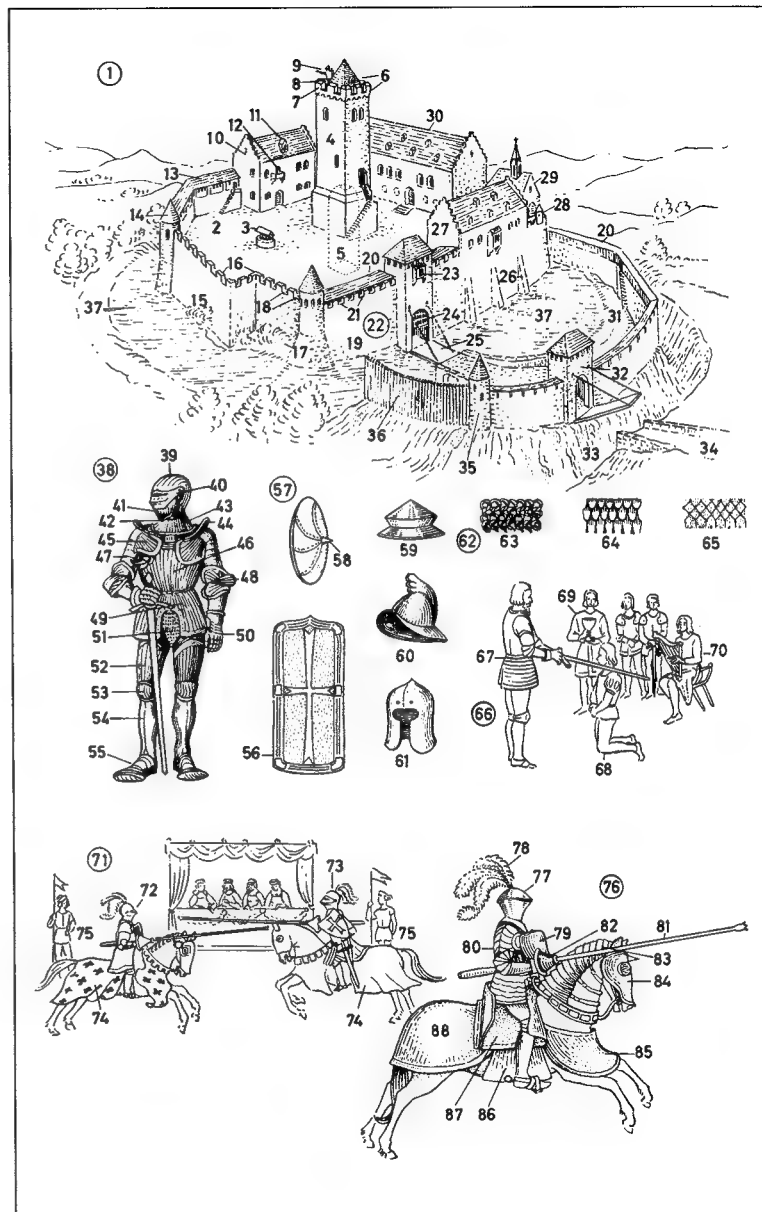

1-30 Protestant church

- 1 chancel
- 2 lectern
- 3 altar carpet
- 4 altar (communion table, Lord's table, holy table)
- 5 altar steps
- 6 altar cloth
- 7 altar candle
- 8 pyx (pix)
- 9 paten (patin, patine)
- 10 chalice (communion cup)
- 11 Bible (Holy Bible, Scriptures, Holy Scripture)
- 12 altar crucifix
- 13 altarpiece
- 14 church window
- 15 stained glass
- 16 wall candelabrum
- 17 vestry door (sacristy door)
- 18 pulpit steps
- 19 pulpit
- 20 antependium
- 21 canopy (soundboard, sounding board)
- 22 preacher (pastor, vicar, clergyman, rector) in his robes (vestments, canonicals)
- 23 pulpit balustrade
- 24 hymn board showing hymn numbers
- 25 gallery
- 26 vergers (sexton, sacristan)
- 27 aisle
- 28 pew; *collectively*: pews (seating)
- 29 churchgoer (worshipper); *collectively*: congregation
- 30 hymn book

- 38 missal (mass book)
- 39 priest
- 40 server
- 41 sedilia
- 42 tabernacle
- 43 stele (stela)
- 44 paschal candle (Easter candle)
- 45 paschal candlestick (Easter candlestick)
- 46 sanctus bell
- 47 processional cross
- 48 altar decoration (foliage, flower arrangement)
- 49 sanctuary lamp
- 50 altarpiece, a picture of Christ
- 51 Madonna (statue of the Virgin Mary)
- 52 pricket
- 53 votive candles
- 54 station of the Cross
- 55 offertory box
- 56 literature stand
- 57 literature (pamphlets, tracts)
- 58 vergers (sexton, sacristan)
- 59 offertory bag
- 60 offering
- 61 man praying
- 62 prayer book

- 31-62 **Roman Catholic church**
- 31 altar steps
- 32 presbytery (choir, chancel, sacristum, sanctuary)
- 33 altar
- 34 altar candles
- 35 altar cross
- 36 altar cloth
- 37 lectern

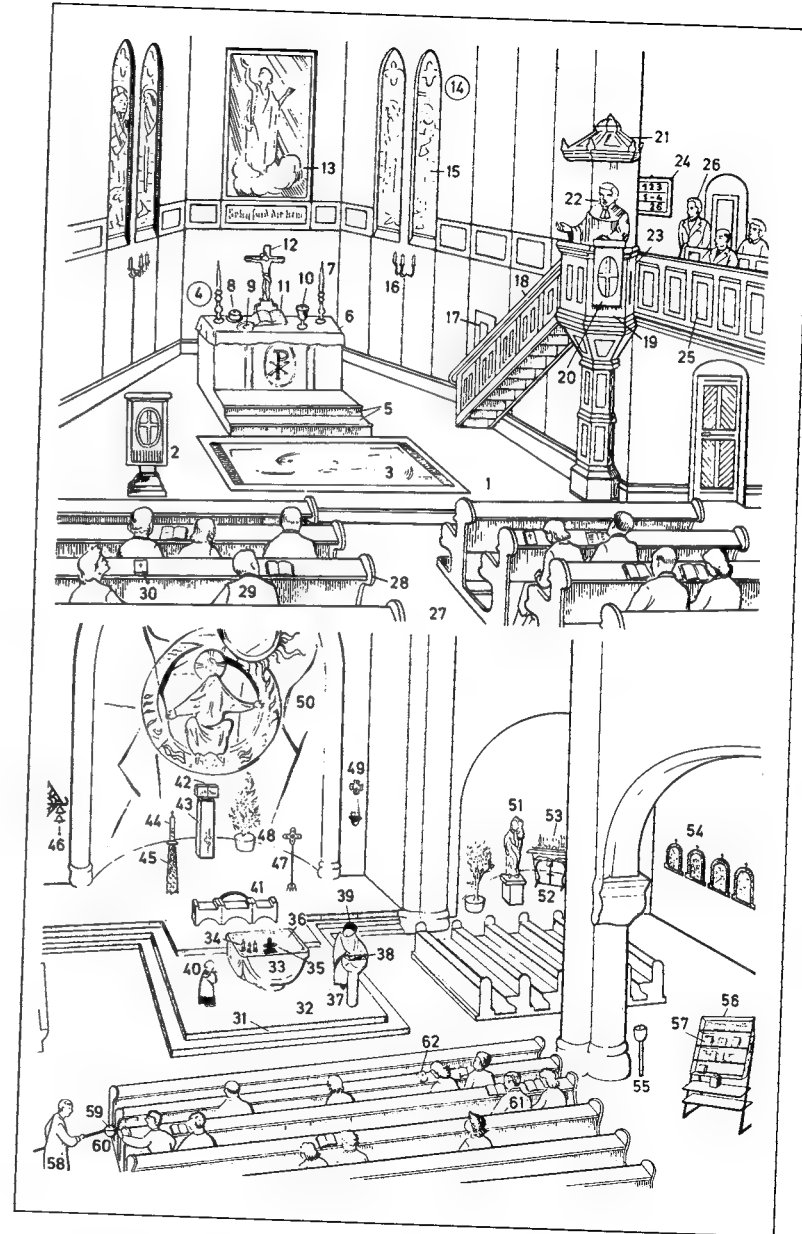

- 1 church
 2 steeple
 3 weathercock
 4 weather vane (wind vane)
 5 spire ball
 6 church spire (spire)
 7 church clock (tower clock)
 8 belfry window
 9 electrically operated bell
 10 ridge cross
 11 church roof
 12 memorial chapel
 13 vestry (sacristy), an annexe (annex)
 14 memorial tablet (memorial plate, wall memorial, wall stone)
 15 side entrance
 16 church door (main door, portal)
 17 churchgoer
 18 graveyard wall (churchyard wall)
 19 graveyard gate (churchyard gate, lichgate, lychgate)
 20 vicarage (parsonage, rectory)
 21-41 graveyard (churchyard, God's acre, *Am.* burying ground)
 21 mortuary
 22 grave digger
 23 grave (tomb)
 24 grave mound
 25 cross
 26 gravestone (headstone, tombstone)
 27 family grave (family tomb)
 28 graveyard chapel
 29 child's grave
 30 urn grave
 31 urn
 32 soldier's grave
 33-41 funeral (burial)
 33 mourners
 34 grave
 35 coffin (*Am.* casket)
 36 spade
 37 clergyman
 38 the bereaved
 39 widow's veil, a mourning veil
 40 pallbearers
 41 bier
 42-50 procession (religious procession)
 42 processional crucifix
 43 cross bearer (crucifer)
 44 processional banner, a church banner
 45 acolyte
 46 canopy bearer
 47 priest
 48 monstrance with the Blessed Sacrament (consecrated Host)
 49 canopy (baldachin, baldaquin)
 50 nuns
 51 participants in the procession
 52-58 monastery
 52 cloister
 53 monastery garden
 54 monk, a Benedictine monk
 55 habit (monk's habit)
 56 cowl (hood)
 57 tonsure
 58 breviary
 59 catacomb, an early Christian underground burial place
 60 niche (tomb recess, arcosolium)
 61 stone slab

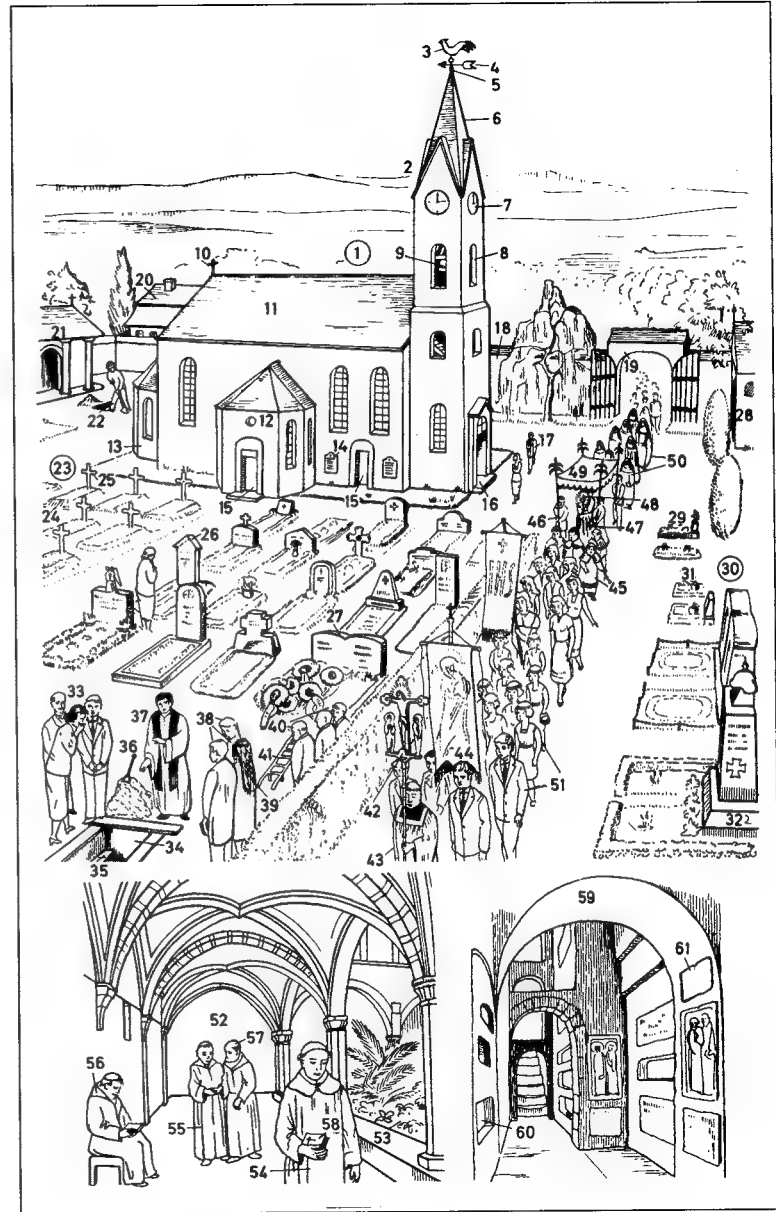

- 1 Christian baptism (christening)
- 2 baptistery (baptistry)
- 3 Protestant clergyman
- 4 robes (vestments, canonicals)
- 5 bands
- 6 collar
- 7 child to be baptized (christened)
- 8 christening robe (christening dress)
- 9 christening shawl
- 10 font
- 11 font basin
- 12 baptismal water
- 13 godparents
- 14 church wedding (wedding ceremony, marriage ceremony)
- 15, 16 bridal couple
- 15 bride
- 16 bridegroom (groom)
- 17 ring (wedding ring)
- 18 bride's bouquet (bridal bouquet)
- 19 bridal wreath
- 20 veil (bridal veil)
- 21 [myrtle] buttonhole
- 22 clergyman
- 23 witnesses [to the marriage]
- 24 bridesmaid
- 25 kneeler
- 26 Holy Communion
- 27 communicants
- 28 Host (wafer)
- 29 communion cup
- 30 rosary
- 31 paternoster
- 32 Ave Maria; set of 10: decade
- 33 crucifix
- 34-54 liturgical vessels (ecclesiastical vessels)
- 34 monstrance
- 35 Host (consecrated Host, Blessed Sacrament)
- 36 lunula (lunule)
- 37 rays
- 38 censer (thurible), for offering incense (for incensing)
- 39 thurible chain
- 40 thurible cover

- 41 thurible bowl
- 42 incense boat
- 43 incense spoon
- 44 cruet set
- 45 water cruet
- 46 wine cruet
- 47 holy water basin
- 48 ciborium containing the sacred wafers
- 49 chalice
- 50 dish for communion wafers
- 51 paten (patin, patine)
- 52 altar bells
- 53 pyx (pix)
- 54 aspergillum
- 55-72 forms of Christian crosses
- 55 Latin cross (cross of the Passion)
- 56 Greek cross
- 57 Russian cross
- 58 St. Peter's cross
- 59 St. Anthony's cross (tau cross)
- 60 St. Andrew's cross (saltire cross)
- 61 Y-cross
- 62 cross of Lorraine
- 63 ansate cross
- 64 patriarchal cross
- 65 cardinal's cross
- 66 papal cross
- 67 Constantinian cross, a monogram of Christ (CHR)
- 68 crosslet
- 69 cross moline
- 70 cross of Jerusalem
- 71 cross botonnée (cross treflée)
- 72 fivefold cross (quintuple cross)
- 73 Celtic cross

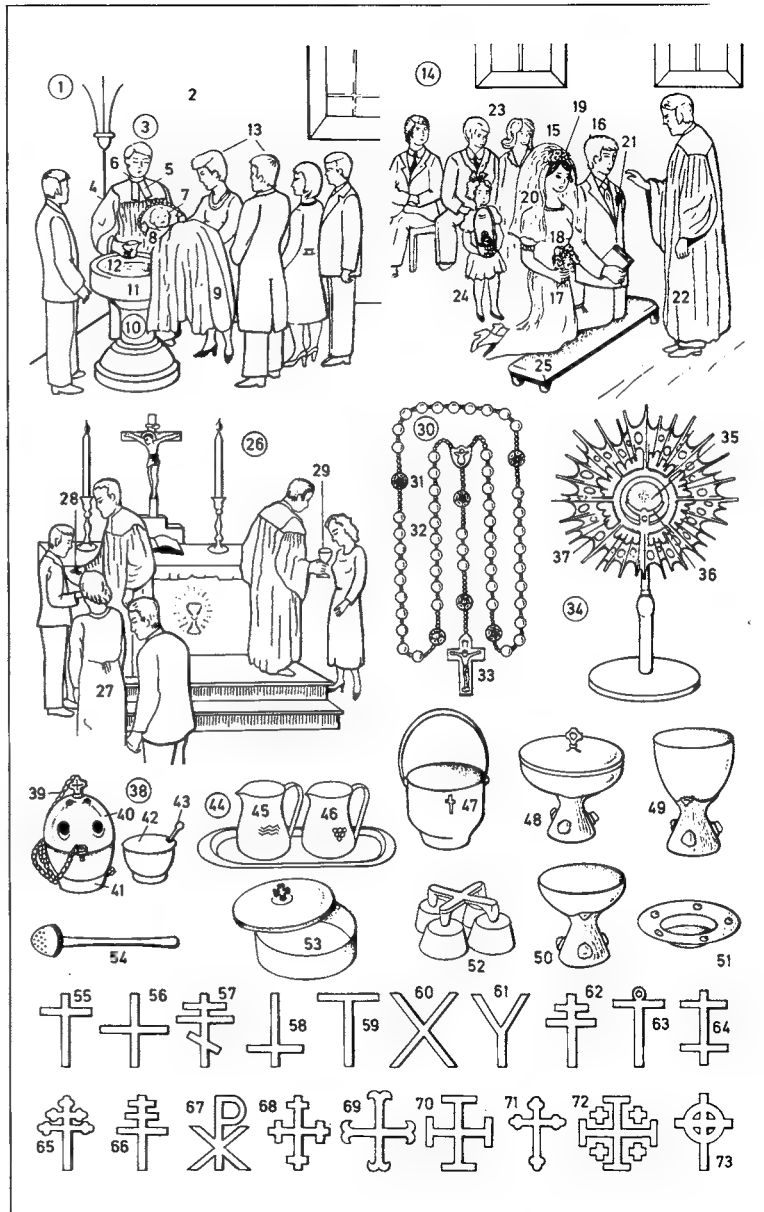

1-18 Egyptian art

- 1 pyramid, a royal tomb
- 2 king's chamber
- 3 queen's chamber
- 4 air passage
- 5 coffin chamber
- 6 pyramid site
- 7 funerary temple
- 8 valley temple
- 9 pylon, a monumental gateway
- 10 obelisks
- 11 Egyptian sphinx
- 12 winged sun disc (sun disk)
- 13 lotus column
- 14 knob-leaf capital (bud-shaped capital)
- 15 papyrus column
- 16 bell-shaped capital
- 17 palm column
- 18 ornamented column

19, 20 Babylonian art

- 19 Babylonian frieze
- 20 glazed relief tile

21-28 art of the Persians

- 21 tower tomb
- 22 stepped pyramid
- 23 double bull column
- 24 projecting leaves
- 25 palm capital
- 26 volute (scroll)
- 27 shaft
- 28 double bull capital

29-36 art of the Assyrians

- 29 Sargon's Palace, palace buildings
- 30 city wall
- 31 castle wall
- 32 temple tower (ziggurat), a stepped (terraced) tower
- 33 outside staircase
- 34 main portal
- 35 portal relief
- 36 portal figure

37 art of Asia Minor

- 38 rock tomb

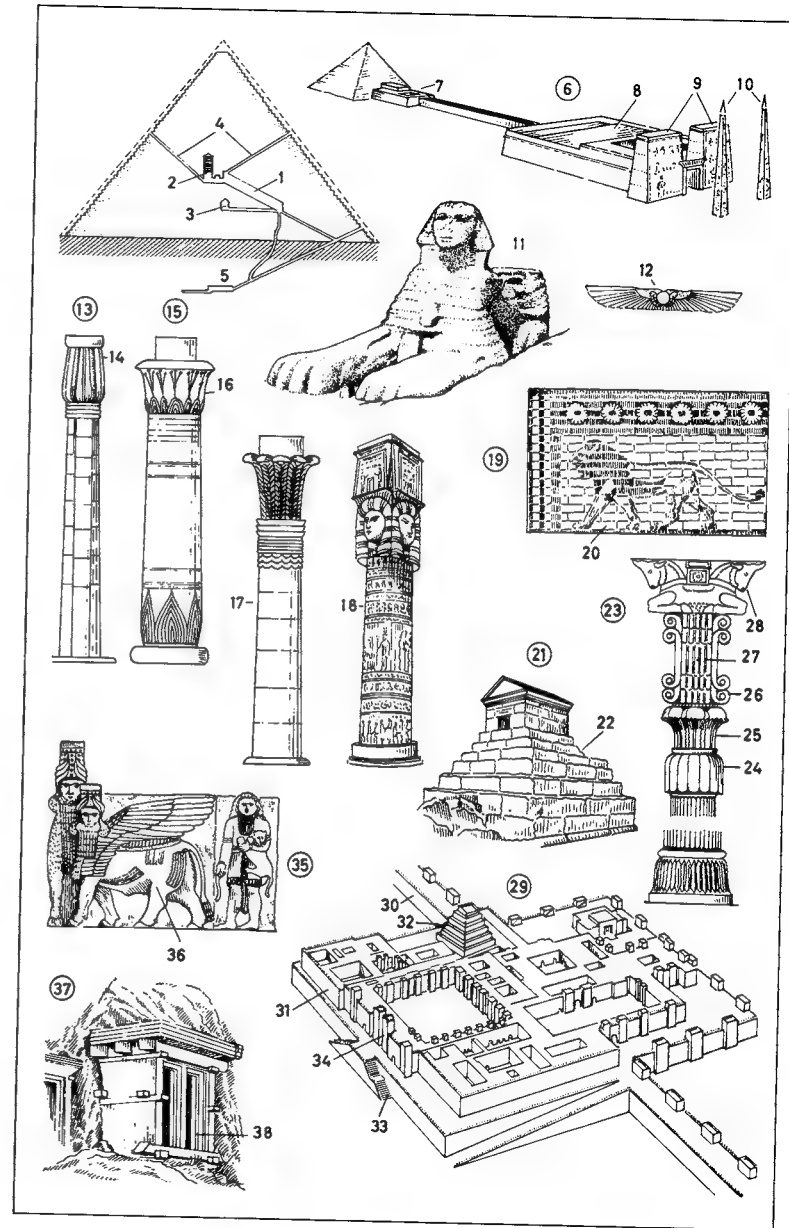

1-48 Greek art

1-7 the Acropolis

1 the Parthenon, a Doric temple

2 peristyle

3 pediment

4 crepidoma (stereobate)

5 statue

6 temple wall

7 propylaea

8 Doric column

9 Ionic column

10 Corinthian column

11-14 cornice

11 cyma

12 corona

13 mutule

14 dentils

15 triglyph

16 metope, a frieze decoration

17 regula

18 epistyle (architrave)

19 cyma (cymatium, kymation)

20-25 capital

20 abacus

21 echinus

22 hypotrachelium (gorgerin)

23 volute (scroll)

24 volute cushion

25 acanthus

26 column shaft

27 flutes (grooves, channels)

28-31 base

28 [upper] torus

29 trochilus (concave moulding, *Am.* moulding)

30 [lower] torus

31 plinth

32 stylobate

33 stele (stela)

34 acroterion (acroterium, acroter)

35 herm (herma, hermes)

36 caryatid; *male*: Atlas

37 Greek vase

38-43 Greek ornamentation (Greek decoration, Greek decorative designs)

38 bead-and-dart moulding (*Am.*

moulding), an ornamental band

39 running dog (Vitruvian scroll)

40 leaf ornament

41 palmette

42 egg and dart (egg and tongue, egg and anchor) cyma

43 meander

44 Greek theatre (*Am.* theater)

45 scene

46 proscenium

47 orchestra

48 thymele (altar)

49-52 Etruscan art

49 Etruscan temple

50 portico

51 cella

52 entablature

53-60 Roman art

53 aqueduct

54 conduit (water channel)

55 centrally-planned building (centralized building)

56 portico

57 reglet

58 cupola

59 triumphal arch

60 attic

61-71 Early Christian art

61 basilica

62 nave

63 aisle

64 apse

65 campanile

66 atrium

67 colonnade

68 fountain

69 altar

70 clerestory (clearstory)

71 triumphal arch

72-75 Byzantine art

72, 73 dome system

72 main dome

73 semidome

74 pendentive

75 eye, a lighting aperture

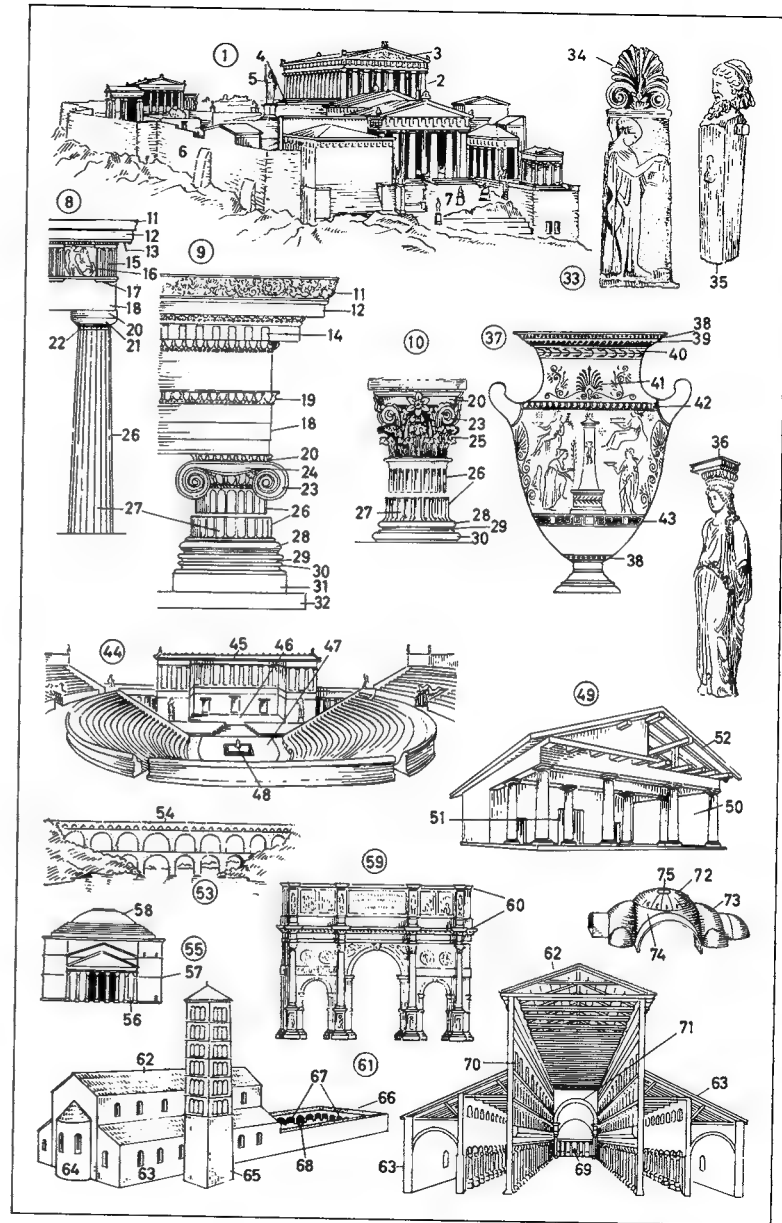

1-21 Romanesque art**1-13 Romanesque church, a cathedral**

- 1 nave
- 2 aisle
- 3 transept
- 4 choir (chancel)
- 5 apse
- 6 central tower (*Am.* center tower)
- 7 pyramidal tower roof
- 8 arcading
- 9 frieze of round arcading
- 10 blind arcade (blind arcading)
- 11 lesene, a pilaster strip
- 12 circular window
- 13 side entrance
- 14-16 Romanesque ornamentation
(Romanesque decoration,
Romanesque decorative designs)
- 14 chequered (*Am.* checkered) pattern
(chequered design)
- 15 imbrication (imbricated design)
- 16 chevron design
- 17 Romanesque system of vaulting
- 18 transverse arch
- 19 barrel vault (tunnel vault)
- 20 pillar
- 21 cushion capital

22-41 Gothic art

- 22 Gothic church [westwork, west
end, west façade], a cathedral
- 23 rose window
- 24 church door (main door, portal), a
recessed portal
- 25 archivolt
- 26 tympanum
- 27-35 Gothic structural system
- 27, 28 buttresses
- 27 buttress
- 28 flying buttress
- 29 pinnacle
- 30 gargoyle
- 31, 32 cross vault (groin vault)
- 31 ribs (cross ribs)
- 32 boss (pendant)
- 33 triforium
- 34 clustered pier (compound pier)

35 respond (engaged pillar)

- 36 pediment
- 37 finial
- 38 crocket
- 39-41 tracery window, a lancet window
- 39, 40 tracery
- 39 quatrefoil
- 40 cinquefoil
- 41 mullions
- 42-54 Renaissance art
- 42 Renaissance church
- 43 projection, a projecting part of the
building
- 44 drum
- 45 lantern
- 46 pilaster (engaged pillar)
- 47 Renaissance palace
- 48 cornice
- 49 pedimental window
- 50 pedimental window with round
gable
- 51 rustication (rustic work)
- 52 string course
- 53 sarcophagus
- 54 festoon (garland)

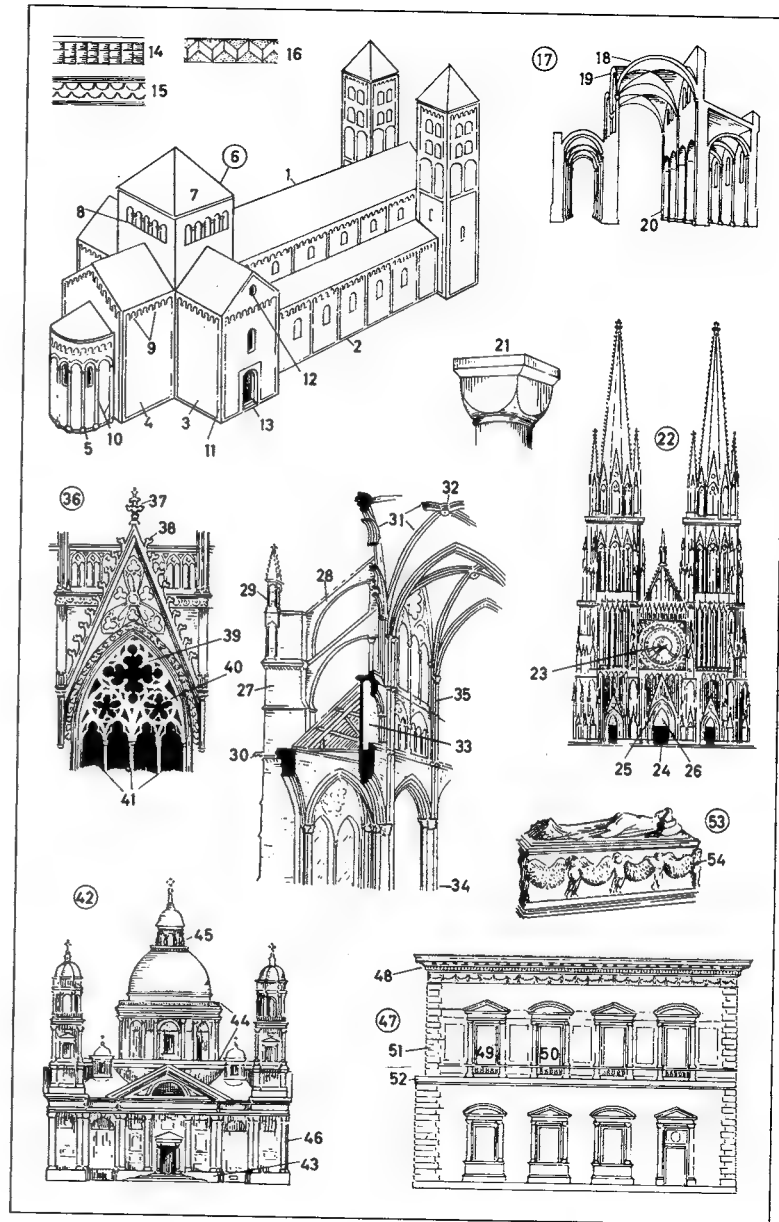

1-8 Baroque art

- 1 Baroque church
- 2 bull's eye
- 3 bulbous cupola
- 4 dormer window (dormer)
- 5 curved gable
- 6 twin columns
- 7 cartouche
- 8 scrollwork
- 9-13 Rococo art
- 9 Rococo wall
- 10 coving, a hollow moulding (*Am.* moulding)
- 11 framing
- 12 ornamental moulding (*Am.* moulding)
- 13 rocaille, a Rococo ornament
- 14 table in Louis Seize style (Louis Seize table)
- 15 neoclassical building (building in neoclassical style), a gateway
- 16 Empire table (table in the Empire style)
- 17 Biedermeier sofa (sofa in the Biedermeier style)
- 18 Art Nouveau easy chair (easy chair in the Art Nouveau style)

19-37 types of arch

- 19 arch
- 20 abutment
- 21 impost
- 22 springer, a voussoir (wedge stone)
- 23 keystone
- 24 face
- 25 intrados
- 26 extrados
- 27 round arch
- 28 segmental arch (basket handle)
- 29 parabolic arch
- 30 horseshoe arch
- 31 lancet arch
- 32 trefoil arch
- 33 shouldered arch
- 34 convex arch
- 35 tented arch
- 36 ogee arch (keel arch)

37 Tudor arch

38-50 types of vault

- 38 barrel vault (tunnel vault)
- 39 crown
- 40 side
- 41 cloister vault (cloistered vault)
- 42 groin vault (groined vault)
- 43 rib vault (ribbed vault)
- 44 stellar vault
- 45 net vault
- 46 fan vault
- 47 trough vault
- 48 trough
- 49 cavetto vault
- 50 cavetto

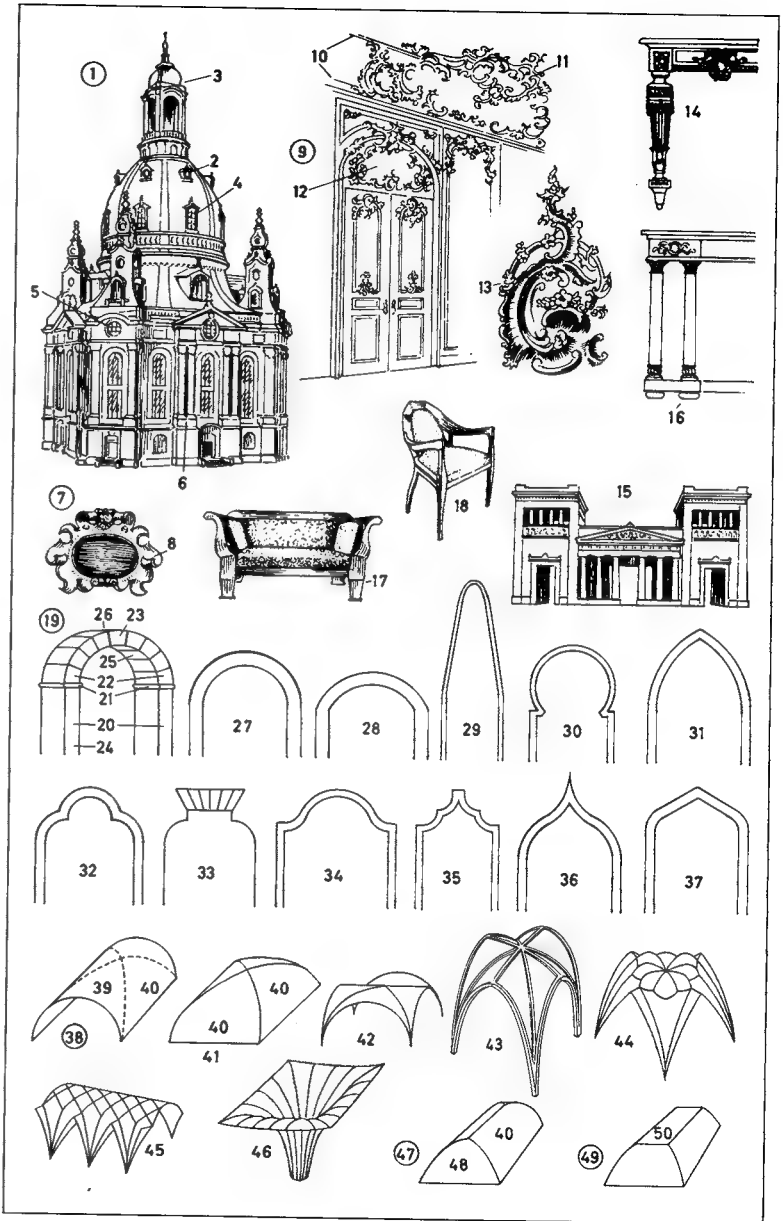

1-6 Chinese art

- 1 pagoda (multi-storey, multistory, pagoda), a temple tower
- 2 storey (story) roof (roof of storey)
- 3 pailou (pailoo), a memorial archway
- 4 archway
- 5 porcelain vase
- 6 incised lacquered work

7-11 Japanese art

- 7 temple
- 8 bell tower
- 9 supporting structure
- 10 bodhisattva (boddhisattva), a Buddhist saint
- 11 torii, a gateway

12-18 Islamic art

- 12 mosque
- 13 minaret, a prayer tower
- 14 mihrab
- 15 minbar (mimbar, pulpit)
- 16 mausoleum, a tomb
- 17 stalactite vault (stalactitic vault)
- 18 Arabian capital

19-28 Indian art

- 19 dancing Siva (Shiva), an Indian god
- 20 statue of Buddha
- 21 stupa (Indian pagoda), a mound (dome), a Buddhist shrine
- 22 umbrella
- 23 stone wall (*Am.* stone fence)
- 24 gate
- 25 temple buildings
- 26 shikara (sika, sikhara, temple tower)
- 27 chaitya hall
- 28 chaitya, a small stupa

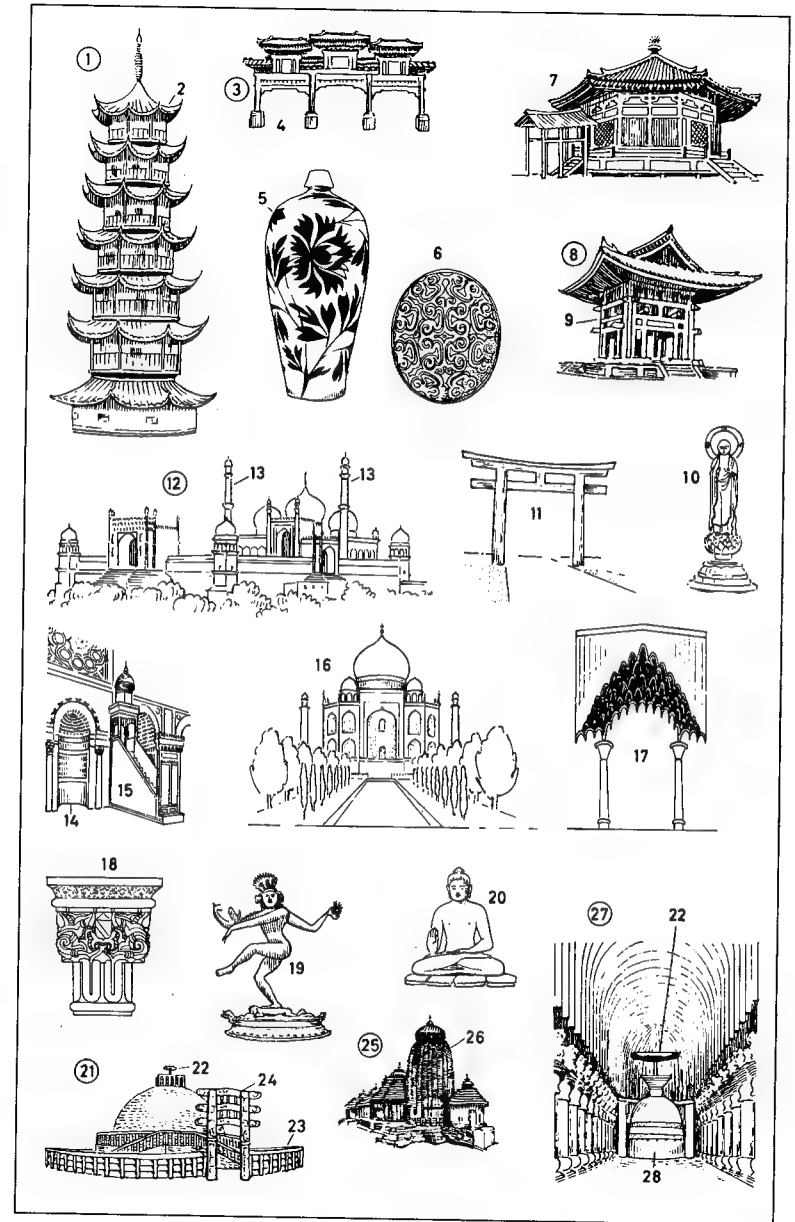

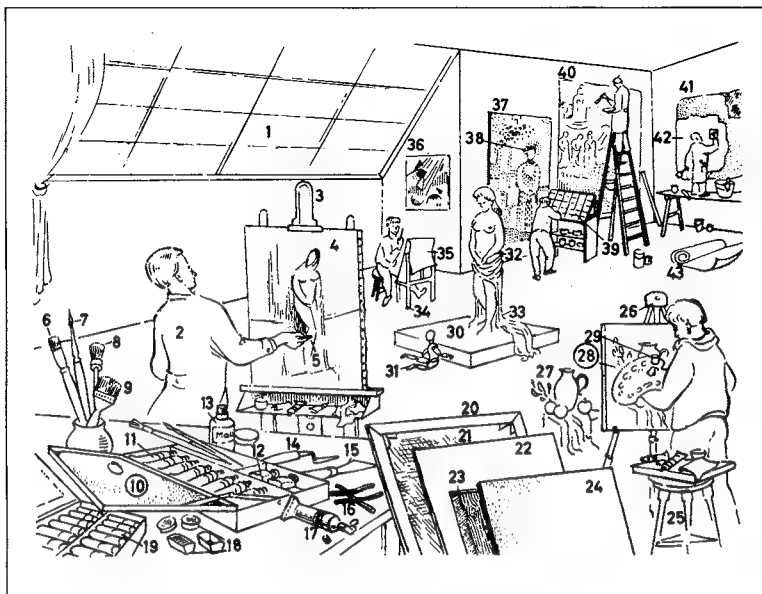

1-43 studio

- | | |
|--|--|
| 1 studio skylight | 22 piece of hardboard, with painting surface |
| 2 painter, an artist | 23 wooden board |
| 3 studio easel | 24 fibreboard (<i>Am.</i> fiberboard) |
| 4 chalk sketch, a rough draft | 25 painting table |
| 5 crayon (piece of chalk) | 26 folding easel |
| 6-19 painting materials | 27 still life group, a motif |
| 6 flat brush | 28 palette |
| 7 camel hair brush | 29 palette dipper |
| 8 round brush | 30 platform |
| 9 priming brush | 31 lay figure (mannequin, manikin) |
| 10 box of paints (paintbox) | 32 nude model (model, nude) |
| 11 tube of oil paint | 33 drapery |
| 12 varnish | 34 drawing easel |
| 13 thinner | 35 sketch pad |
| 14 palette knife | 36 study in oils |
| 15 spatula | 37 mosaic (tessellation) |
| 16 charcoal pencil (charcoal, piece of charcoal) | 38 mosaic figure |
| 17 tempera (gouache) | 39 tesserae |
| 18 watercolour (<i>Am.</i> watercolor) | 40 fresco (mural) |
| 19 pastel crayon | 41 sgraffito |
| 20 wedged stretcher (canvas stretcher) | 42 plaster |
| 21 canvas | 43 cartoon |

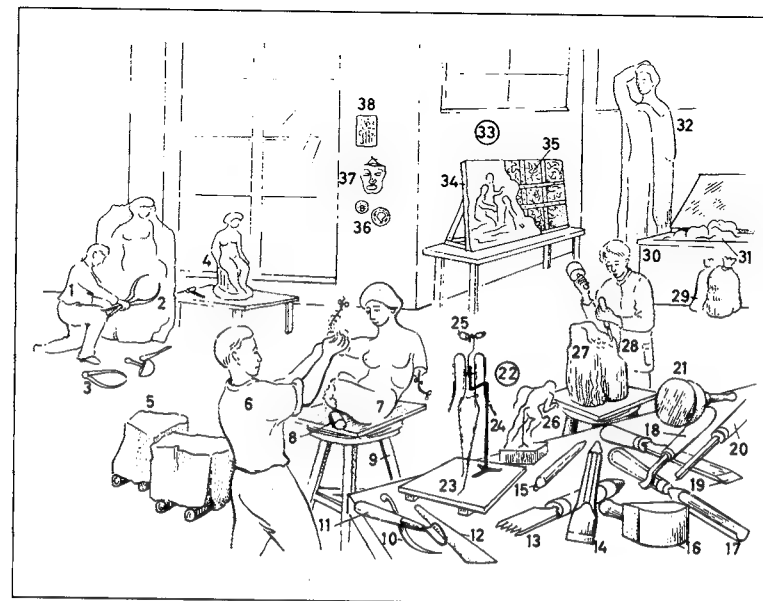

- | | |
|--|---|
| 1 sculptor | 20 V-shaped gouge |
| 2 proportional dividers | 21 mallet |
| 3 calliper (caliper) | 22 framework |
| 4 plaster model, a plaster cast | 23 baseboard |
| 5 block of stone (stone block) | 24 armature support (metal rod) |
| 6 modeller (<i>Am.</i> modeler) | 25 armature |
| 7 clay figure, a torso | 26 wax model |
| 8 roll of clay, a modelling (<i>Am.</i> modeling) substance | 27 block of wood |
| 9 modelling (<i>Am.</i> modeling) stand | 28 wood carver (wood sculptor) |
| 10 wooden modelling (<i>Am.</i> modeling) tool | 29 sack of gypsum powder (gypsum) |
| 11 wire modelling (<i>Am.</i> modeling) tool | 30 clay box |
| 12 beating wood | 31 modelling (<i>Am.</i> modeling) clay |
| 13 claw chisel (toothed chisel, tooth chisel) | 32 statue, a sculpture |
| 14 flat chisel | 33 low relief (bas-relief) |
| 15 point (punch) | 34 modelling (<i>Am.</i> modeling) board |
| 16 iron-headed hammer | 35 wire frame, wire netting |
| 17 gouge (hollow chisel) | 36 circular medallion (tondo) |
| 18 spoon chisel | 37 mask |
| 19 wood chisel, a bevelled-edge chisel | 38 plaque |

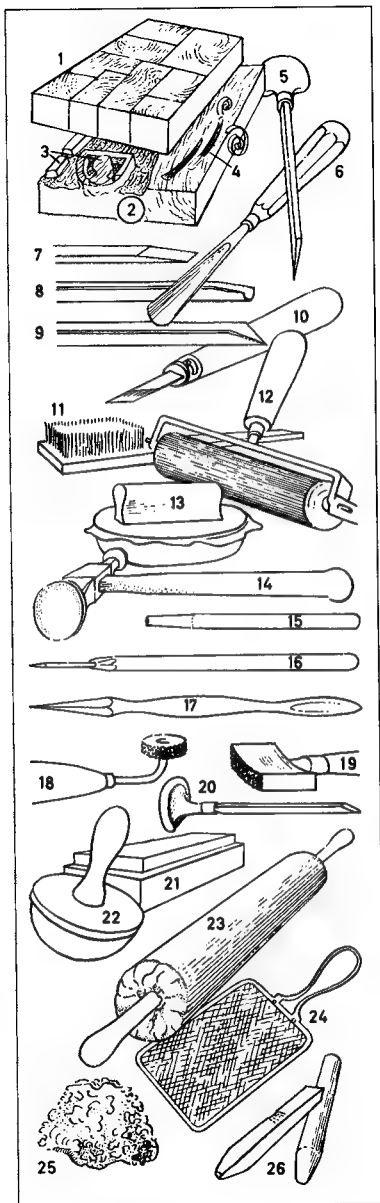

1-13 wood engraving (xylography), a relief printing method (a letterpress printing method)

- 1 end-grain block for wood engravings, a wooden block
- 2 wooden plank for woodcutting, a relief image carrier
- 3 positive cut
- 4 plank cut
- 5 burin (graver)
- 6 U-shaped gouge
- 7 scoper (scauper, scalper)
- 8 scoop
- 9 V-shaped gouge
- 10 contour knife
- 11 brush
- 12 roller (brayer)
- 13 pad (wiper)

14-24 copperplate engraving (chalcography), an intaglio process; *kinds*: etching, mezzotint, aquatint, crayon engraving

- 14 hammer
- 15 burin
- 16 etching needle (engraver)
- 17 scraper and burnisher
- 18 roulette
- 19 rocking tool (rocker)
- 20 round-headed graver, a graver (burin)
- 21 oilstone
- 22 dabber (inking ball, ink ball)
- 23 leather roller
- 24 sieve
- 25, 26 lithography (stone lithography), a planographic printing method
- 25 sponge for moistening the lithographic stone
- 26 lithographic crayons (greasy chalk)

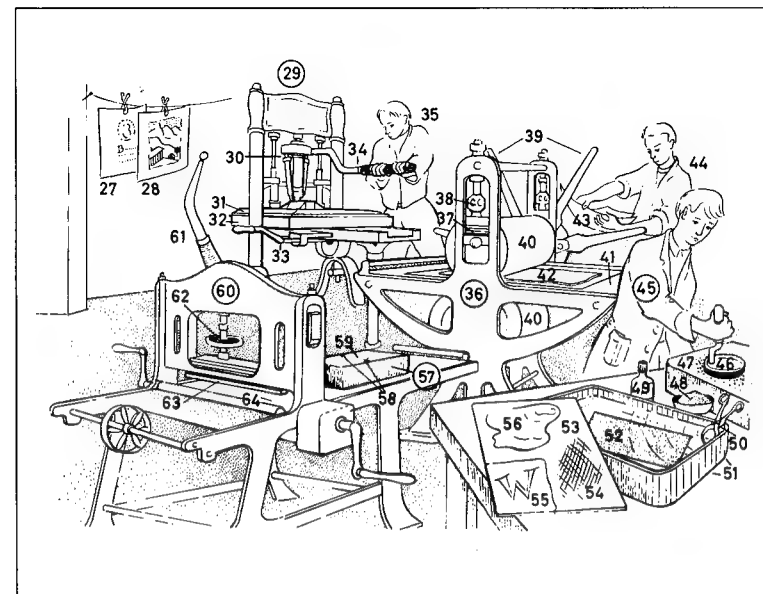

27-64 graphic art studio, a printing office (*Am. printery*)











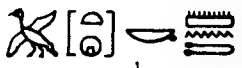
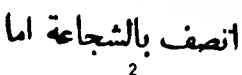

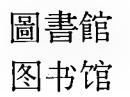

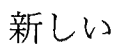
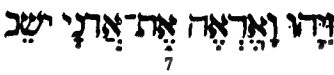
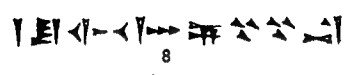
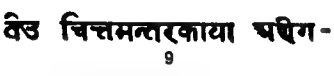

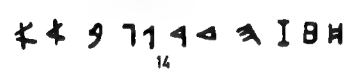

- 27 broadside (broadsheet, single sheet)
- 28 full-colour (*Am. full-color*) print (colour print, chromolithograph)
- 29 platen press, a hand press
- 30 toggle
- 31 platen
- 32 type forme (*Am. form*)
- 33 feed mechanism
- 34 bar (devil's tail)
- 35 pressman
- 36 copperplate press
- 37 tympan
- 38 pressure regulator
- 39 star wheel
- 40 cylinder
- 41 bed
- 42 felt cloth
- 43 proof (pull)
- 44 copperplate engraver

45 lithographer (litho artist), grinding the stone

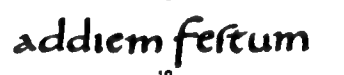
- 46 grinding disc (disk)
- 47 grain (granular texture)
- 48 pulverized glass
- 49 rubber solution
- 50 tongs
- 51 etching bath for etching
- 52 zinc plate
- 53 polished copperplate
- 54 cross hatch
- 55 etching ground
- 56 non-printing area
- 57 lithographic stone
- 58 register marks
- 59 printing surface (printing image carrier)
- 60 lithographic press
- 61 lever
- 62 scraper adjustment
- 63 scraper
- 64 bed

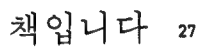
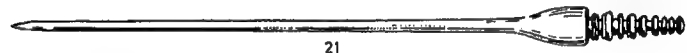
1-20 scripts of various peoples

- 1 ancient Egyptian hieroglyphics, pictorial system of writing
- 2 Arabic
- 3 Armenian
- 4 Georgian
- 5 Chinese
- 6 Japanese
- 7 Hebrew (Hebraic)
- 8 cuneiform script
- 9 Devanagari, script employed in Sanskrit
- 10 Siamese
- 11 Tamil
- 12 Tibetan
- 13 Sinaitic script
- 14 Phoenician
- 15 Greek
- 16 Roman capitals
- 17 uncial (uncials, uncial script)
- 18 Carolingian (Carlovingian, Caroline) minuscule
- 19 runes
- 20 Cyrillic
- 21-26 ancient writing implements
- 21 Indian steel stylus for writing on palm leaves
- 22 ancient Egyptian reed pen
- 23 writing cane
- 24 brush
- 25 Roman metal pen (stylus)
- 26 quill (quill pen)
- 27 Korean

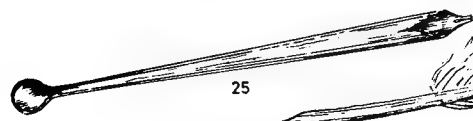
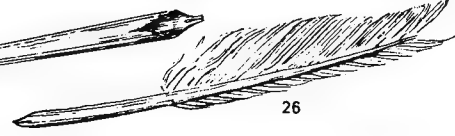
 <p>1</p>	 <p>2</p>	 <p>3</p>	 <p>5</p>
 <p>4</p>	 <p>5</p>	 <p>7</p>	 <p>8</p>
 <p>9</p>	 <p>10</p>	 <p>11</p>	 <p>12</p>
 <p>13</p>	 <p>14</p>	 <p>15</p>	 <p>16</p>
 <p>17</p>	 <p>18</p>	 <p>19</p>	 <p>20</p>
 <p>27</p>			
 <p>21</p>			
 <p>22</p>			
 <p>23</p>			
 <p>24</p>			
 <p>25</p>			
 <p>26</p>			

- 1-15 types (type faces)
 1 Gothic type (German black-letter type)
 2 Schwabacher type (German black-letter type)
 3 Fraktur (German black-letter type)
 4 Humanist (Mediaeval)
 5 Transitional
 6 Didone
 7 Sanserif (Sanserif type, Grotesque)
 8 Egyptian
 9 typescript (typewriting)
 10 English hand (English handwriting, English writing)
 11 German hand (German handwriting, German writing)
 12 Latin script
 13 shorthand (shorthand writing, stenography)
 14 phonetics (phonetic transcription)
 15 Braille
- 16-29 punctuation marks (stops)
 16 full stop (period, full point)
 17 colon
 18 comma
 19 semicolon
 20 question mark (interrogation point, interrogation mark)
 21 exclamation mark (*Am.* exclamation point)
 22 apostrophe
 23 dash (em rule)
 24 parentheses (round brackets)
 25 square brackets
 26 quotation mark (double quotation marks, paired quotation marks, inverted commas)
 27 guillemet (French quotation mark)
 28 hyphen
 29 marks of omission (ellipses)
- 30-35 accents and diacritical marks (diacritics)
 30 acute accent (acute)
 31 grave accent (grave)
 32 circumflex accent (circumflex)
 33 cedilla [under c]
- 34 diaeresis (*Am.* dieresis) [over e]
 35 tilde [over n]
 36 section mark
- 37-70 newspaper, a national daily newspaper
 37 newspaper page
 38 front page
 39 newspaper heading
 40 contents
 41 price
 42 date of publication
 43 place of publication
 44 headline
 45 column
 46 column heading
 47 column rule
 48 leading article (leader, editorial)
 49 reference to related article
 50 brief news item
 51 political section
 52 page heading
 53 cartoon
 54 report by newspaper's own correspondent
 55 news agency's sign
 56 advertisement (*coll. ad*)
 57 sports section
 58 press photo
 59 caption
 60 sports report
 61 sports news item
 62 home and overseas news section
 63 news in brief (miscellaneous news)
 64 television programmes (*Am.* programs)
 65 weather report
 66 weather chart (weather map)
 67 arts section (feuilleton)
 68 death notice
 69 advertisements (classified advertising)
 70 job advertisement, a vacancy (a situation offered)



- 1 red
- 2 yellow
- 3 blue
- 4 pink
- 5 brown
- 6 azure (sky blue)
- 7 orange
- 8 green
- 9 violet
- 10 additive mixture of colours (*Am. colors*)
- 11 white
- 12 subtractive mixture of colours (*Am. colors*)
- 13 black
- 14 solar spectrum (colours, *Am. colors*, of the rainbow)
- 15 grey (*Am. gray*) scale
- 16 heat colours (*Am. colors*)



- ① I II III IV V VI VII VIII IX X
 ② 1 2 3 4 5 6 7 8 9 10
- ① XX XXX XL XLIX IL L LX LXX LXXX XC
 ② 20 30 40 49 50 60 70 80 90
- ① XCIX IC C CC CCC CD D DC DCC DCCC
 ② 99 100 200 300 400 500 600 700 800
- ① CM CMXC M
 ② 900 990 1000
- ③ 9658 ④ 5 kg. ⑤ 2 ⑥ 2nd ⑦ +5 ⑧ -5

1-26 arithmetic**1-22 numbers**

- 1** Roman numerals
2 Arabic numerals
3 abstract number, a four-figure number [8: units; 5: tens; 6: hundreds; 9: thousands]
4 concrete number (physical quantity consisting of the numerical value and the unit or unit symbol)
5 cardinal number (cardinal)
6 ordinal number (ordinal)
7 positive number [with plus sign]
8 negative number [with minus sign]
9 algebraic symbols
10 mixed number [3: whole number (integer); $\frac{1}{3}$: fraction]
11 even numbers
12 odd numbers
13 prime numbers

14 complex number [3: real part; $2\sqrt{-1}$: imaginary part]

15, 16 vulgar fractions

15 proper fraction [2: numerator, horizontal line; 3: denominator]

16 improper fraction, also the reciprocal of item 15

17 compound fraction (complex fraction)

18 improper fraction [when cancelled down produces a whole number]

19 fractions of different denominations [35: common denominator]

20 proper decimal fraction with decimal point and decimal places [3: tenths; 5: hundredths; 7: thousandths]

21, 22 recurring decimal

⑨ a, b, c... ⑩ $3\frac{1}{3}$ ⑪ 2, 4, 6, 8 ⑫ 1, 3, 5, 7

⑬ 3, 5, 7, 11 ⑭ $3 + 2\sqrt{-1}$ ⑮ $\frac{2}{3}$ ⑯ $\frac{3}{2}$

⑰ $\frac{\frac{5}{6}}{\frac{3}{4}}$ ⑱ $\frac{12}{4}$ ⑲ $\frac{4}{5} + \frac{2}{7} = \frac{38}{35}$ ⑳ 0.357

㉑ $0.6666\dots = 0.\bar{6}$ ㉒ $3 + 2 = 5$

㉔ $3 - 2 = 1$ ㉕ $3 \cdot 2 = 6$
 $3 \times 2 = 6$ ㉖ $6 \div 2 = 3$

23-26 fundamental arithmetical operations

- 23** addition (adding) [3 and 2: the terms of the sum; + : plus sign; = : equals sign; 5: the sum]
24 subtraction (subtracting); [3: the minuend; - : minus sign; 2: the subtrahend; 1: the remainder (difference)]
25 multiplication (multiplying); [3: the multiplicand; \times : multiplication sign; 2: the multiplier; 2 and 3: factors; 6: the product]
26 division (dividing); [6: the dividend; \div : division sign; 2: the divisor; 3: the quotient]

$$\textcircled{1} 3^2 = 9 \quad \textcircled{2} \sqrt[3]{8} = 2 \quad \textcircled{3} \sqrt{4} = 2$$

$$\textcircled{4} 3x + 2 = 12$$

⑥

$$\textcircled{5} 4a + 6ab - 2ac = 2a(2 + 3b - c) \quad \log_{10} 3 = 0.4771$$

$$\textcircled{7} \frac{P[\pounds 1000] \times R[5\%] \times T[2 \text{ years}]}{100} = I[\pounds 100]$$

1-24 arithmetic

1-10 advanced arithmetical operations

- 1** raising to a power [three squared (3^2): the power; 3: the base; 2: the exponent (index); 9: value of the power]
2 evolution (extracting a root); [cube root of 8; cube root; 8: the radical; 3: the index (degree) of the root; $\sqrt{\quad}$: radical sign; 2: value of the root]
3 square root
4, 5 algebra
4 simple equation [3, 2: the coefficients; x : the unknown quantity]
5 identical equation; [a, b, c: algebraic symbols]
6 logarithmic calculation (taking the logarithm, log); [log: logarithm sign; 3: number whose logarithm is required; 10: the base; 0: the characteristic; 4771: the mantissa; 0.4771: the logarithm]

- 7** simple interest formula [P: the principal; R: rate of interest; T: time; I: interest (profit); %: percentage sign]

8-10 rule of three (rule-of-three sum, simple proportion)

- 8** statement with the unknown quantity \times
9 equation (conditional equation)

10 solution

11-14 higher mathematics

- 11** arithmetical series with the elements 2, 4, 6, 8
12 geometrical series
13, 14 infinitesimal calculus
13 derivative [dx, dy: the differentials; d: differential sign]
14 integral (integration) [x: the variable; C: constant of integration; \int : the integral sign; dx: the differential]

$$\textcircled{8} \begin{array}{l} 2 \text{ years @ } \pounds 50 \\ 4 \text{ years @ } \pounds x \end{array} \quad \textcircled{11} 2 + 4 + 6 + 8 \dots$$

$$\textcircled{9} 2 : 50 = 4 : x$$

$$\textcircled{10} x = \pounds 100$$

$$\textcircled{12} 2 + 4 + 8 + 16 + 32 \dots \quad \textcircled{13} \frac{dy}{dx}$$

$$\int ax dx = a \int x dx = \frac{ax^2}{2} + C$$

$$\textcircled{15} \infty$$

$$\textcircled{16} \equiv$$

$$\textcircled{17} \approx$$

$$\textcircled{18} \neq$$

$$\textcircled{19} >$$

$$\textcircled{20} <$$

$$\textcircled{21} \parallel$$

$$\textcircled{22} \sim$$

$$\textcircled{23} \triangleleft$$

$$\textcircled{24} \triangle$$

15-24 mathematical symbols

- 15** infinity
16 identically equal to (the sign of identity)
17 approximately equal to
18 unequal to
19 greater than
20 less than
21-24 geometrical symbols
21 parallel (sign of parallelism)
22 similar to (sign of similarity)
23 angle symbol
24 triangle symbol

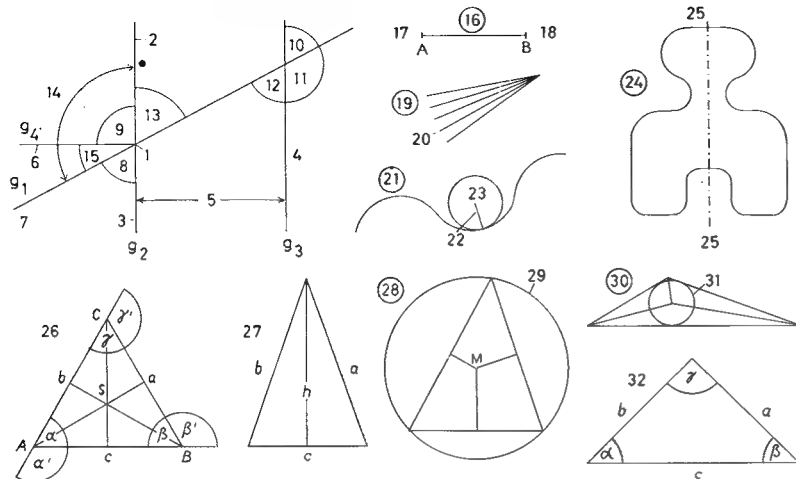

1-58 plane geometry (elementary geometry, Euclidian geometry)

1-23 point, line, angle

1 point [point of intersection of g_1 and g_2], the angular point of **8**

2, 3 straight line g_2

4 the parallel to g_2

5 distance between the straight lines g_2 and g_3

6 perpendicular (g_4) on g_2

7, 3 the arms of **8**

8, 13 vertically opposite angles

8 angle

9 right angle [90°]

10, 11, 12 reflex angle

10 acute angle, also the alternate angle to **8**

11 obtuse angle

12 corresponding angle to **10**

13, 9, 15 straight angle [180°]

14 adjacent angle; *here*: supplementary angle to **13**

15 complementary angle to **8**

16 straight line AB

17 end A

18 end B

19 pencil of rays

20 ray

21 curved line

22 radius of curvature

23 centre (*Am. center*) of curvature

24-58 plane surfaces

24 symmetrical figure

25 axis of symmetry

26-32 plane triangles

26 equilateral triangle [A, B, C: the vertices; a, b, c: the sides; α (alpha), β (beta), γ (gamma): the interior angles; α' , β' , γ' : the exterior angles; S: the centre (*Am. center*)]

27 isosceles triangle [a, b: the sides (legs); c: the base; h: the perpendicular, an altitude]

28 acute-angled triangle with perpendicular bisectors of the sides

29 circumcircle (circumscribed circle)

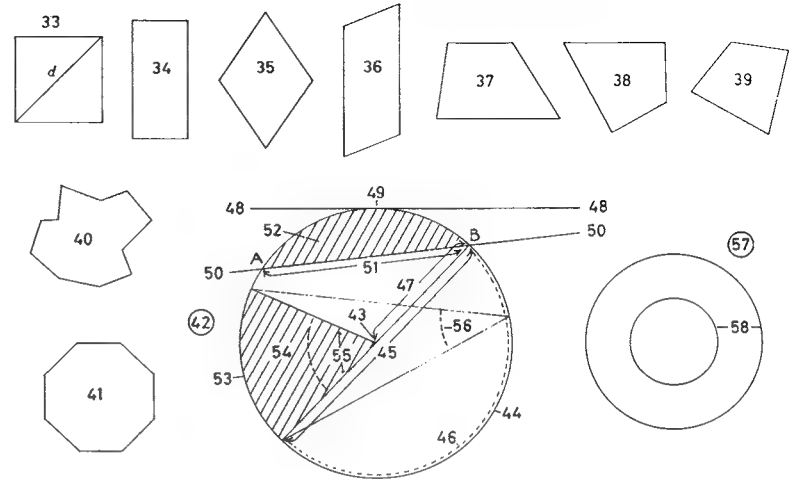

30 obtuse-angled triangle with bisectors of the angles

31 inscribed circle

32 right-angled triangle and the trigonometrical functions of angles [a, b: the catheti; c: the hypotenuse; γ : the right angle; $a/c = \sin \alpha$ (sine); $b/c = \cos \alpha$ (cosine); $a/b = \tan \alpha$ (tangent); $b/a = \cot \alpha$ (cotangent)]

33-39 quadrilaterals

33-36 parallelograms

33 square [d: a diagonal]

34 rectangle

35 rhombus (rhomb, lozenge)

36 rhomboid

37 trapezium

38 deltoid (kite)

39 irregular quadrilateral

40 polygon

41 regular polygon

42 circle

43 centre (*Am. center*)

44 circumference (periphery)

45 diameter

46 semicircle

47 radius (r)

48 tangent

49 point of contact (P)

50 secant

51 the chord AB

52 segment

53 arc

54 sector

55 angle subtended by the arc at the centre (*Am. center*) (centre, *Am. center*, angle)

56 circumferential angle

57 ring (annulus)

58 concentric circles

- 1 system of right-angled coordinates
- 2, 3 axes of coordinates (coordinate axes)
- 2 axis of abscissae (x-axis)
- 3 axis of ordinates (y-axis)
- 4 origin of ordinates
- 5 quadrant [I-IV: 1st to 4th quadrant]
- 6 positive direction
- 7 negative direction
- 8 points $[P_1$ and $P_2]$ in the system of coordinates; x_1 and y_1 [and x_2 and y_2 respectively] their coordinates
- 9 values of the abscissae $[x_1$ and $x_2]$ (the abscissae)
- 10 values of the ordinates $[y_1$ and $y_2]$ (the ordinates)
- 11-29 conic sections
- 11 curves in the system of coordinates
- 12 plane curves [a: the gradient (slope) of the curve; b: the ordinates' intersection of the curve; c: the root of the curve]
- 13 inflected curves
- 14 parabola, \cap curve of the second degree
- 15 branches of the parabola
- 16 vertex of the parabola
- 17 axis of the parabola
- 18 a curve of the third degree
- 19 maximum of the curve
- 20 minimum of the curve
- 21 point of inflexion (of inflection)
- 22 ellipse
- 23 transverse axis (major axis)
- 24 conjugate axis (minor axis)
- 25 foci of the ellipse $[F_1$ and $F_2]$
- 26 hyperbola
- 27 foci $[F_1$ and $F_2]$
- 28 vertices $[S_1$ and $S_2]$
- 29 asymptotes [a and b]
- 30-46 solids
- 30 cube
- 31 square, a plane (plane surface)
- 32 edge

- 33 corner
- 34 quadratic prism
- 35 base
- 36 parallelepiped
- 37 triangular prism
- 38 cylinder, a right cylinder
- 39 base, a circular plane
- 40 curved surface
- 41 sphere
- 42 ellipsoid of revolution
- 43 cone
- 44 height of the cone (cone height)
- 45 truncated cone (frustum of a cone)
- 46 quadrilateral pyramid

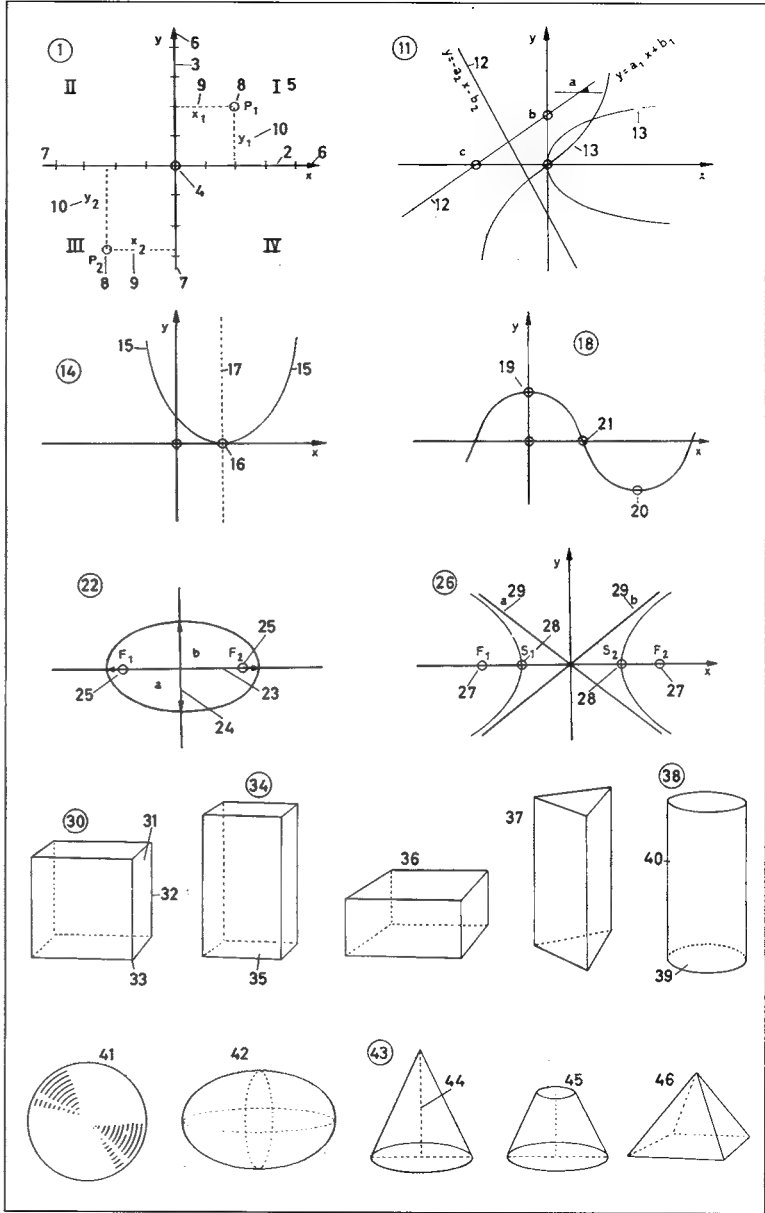

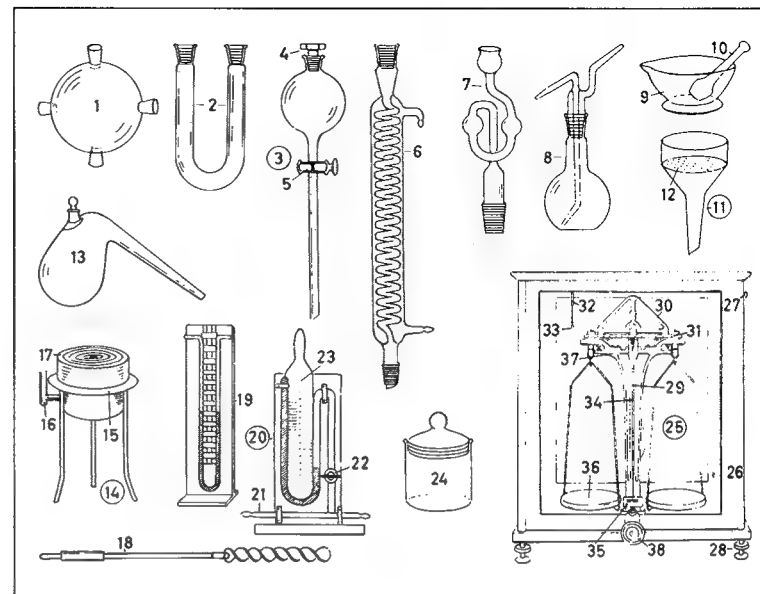
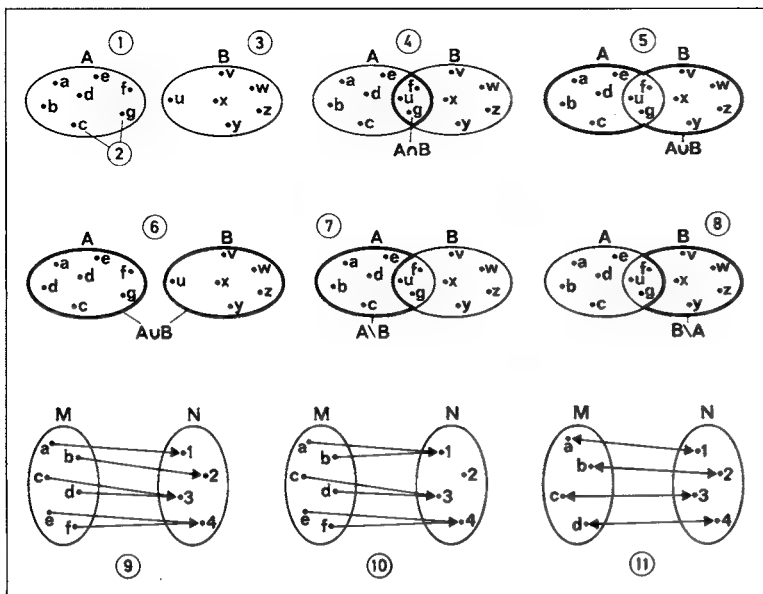

1-38 laboratory apparatus (laboratory equipment)

- | | |
|--|---|
| 1 Scheidt globe | 20 mirror manometer for measuring small pressures |
| 2 U-tube | 21 inlet |
| 3 separating funnel | 22 tap (<i>Am. faucet</i>) |
| 4 octagonal ground-glass stopper | 23 sliding scale |
| 5 tap (<i>Am. faucet</i>) | 24 weighing bottle |
| 6 coiled condenser | 25 analytical balance |
| 7 air lock | 26 case |
| 8 wash-bottle | 27 sliding front panel |
| 9 mortar | 28 three-point support |
| 10 pestle | 29 column (balance column) |
| 11 filter funnel (Büchner funnel) | 30 balance beam (beam) |
| 12 filter (filter plate) | 31 rider bar |
| 13 retort | 32 rider holder |
| 14 water bath | 33 rider |
| 15 tripod | 34 pointer |
| 16 water gauge (<i>Am. gage</i>) | 35 scale |
| 17 insertion rings | 36 scale pan |
| 18 stirrer | 37 stop |
| 19 manometer for measuring positive and negative pressures | 38 stop knob |

1-63 laboratory apparatus (laboratory equipment)

- 1 Bunsen burner
- 2 gas inlet (gas inlet pipe)
- 3 air regulator
- 4 Teclu burner
- 5 pipe union
- 6 gas regulator
- 7 stem
- 8 air regulator
- 9 bench torch
- 10 casing
- 11 oxygen inlet
- 12 hydrogen inlet
- 13 oxygen jet
- 14 tripod
- 15 ring (retort ring)
- 16 funnel
- 17 pipe clay triangle
- 18 wire gauze
- 19 wire gauze with asbestos centre (*Am. center*)
- 20 beaker
- 21 burette (for measuring the volume of liquids)
- 22 burette stand
- 23 burette clamp
- 24 graduated pipette
- 25 pipette
- 26 measuring cylinder (measuring glass)
- 27 measuring flask
- 28 volumetric flask
- 29 evaporating dish (evaporating basin), made of porcelain
- 30 tube clamp (tube clip, pinchcock)
- 31 clay crucible with lid
- 32 crucible tongs
- 33 clamp
- 34 test tube
- 35 test tube rack
- 36 flat-bottomed flask
- 37 ground glass neck
- 38 long-necked round-bottomed flask
- 39 Erlenmeyer flask (conical flask)
- 40 filter flask

- 41 fluted filter
- 42 one-way tap
- 43 calcium chloride tube
- 44 stopper with tap
- 45 cylinder
- 46 distillation apparatus (distilling apparatus)
- 47 distillation flask (distilling flask)
- 48 condenser
- 49 return tap, a two-way tap
- 50 distillation flask (distilling flask, Claisen flask)
- 51 desiccator
- 52 lid with fitted tube
- 53 tap
- 54 desiccator insert made of porcelain
- 55 three-necked flask
- 56 connecting piece (Y-tube)
- 57 three-necked bottle
- 58 gas-washing bottle
- 59 gas generator (Kipp's apparatus, *Am. Kipp generator*)
- 60 overflow container
- 61 container for the solid
- 62 acid container
- 63 gas outlet

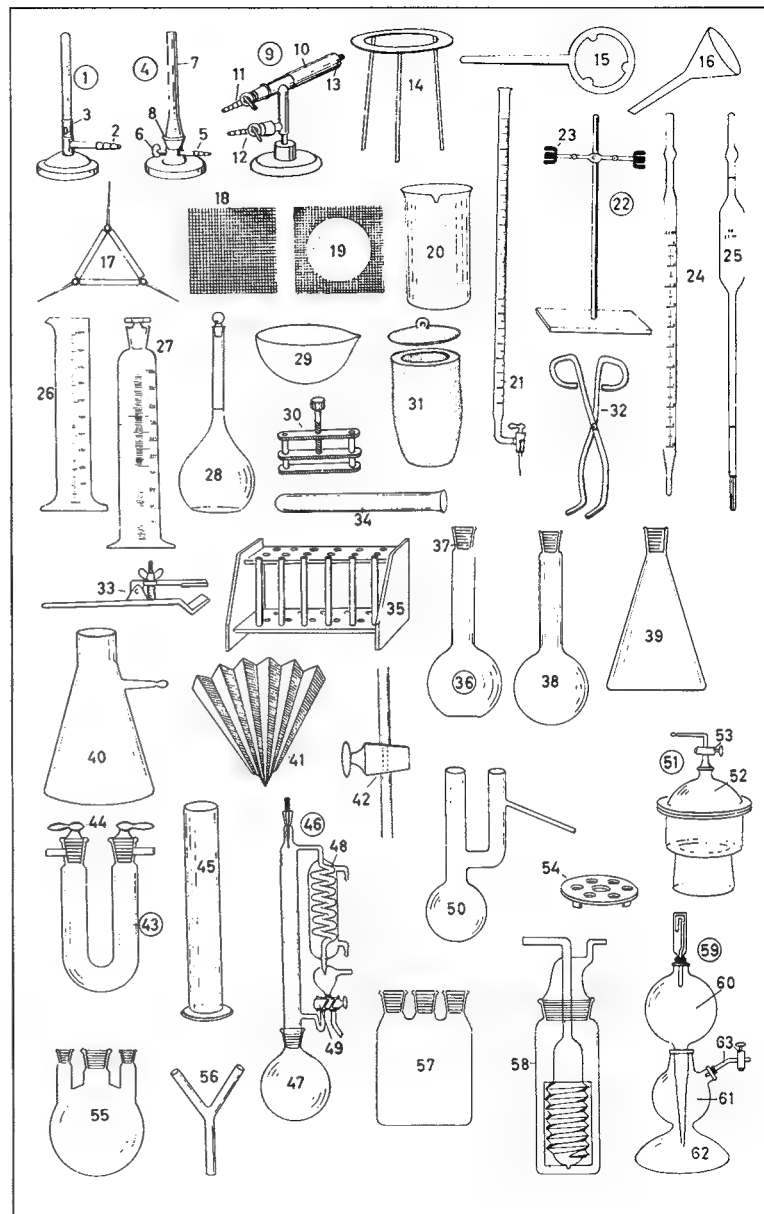

- 1-26 basic crystal forms and crystal combinations** [structure of crystals]
- 1-17 regular** (cubic, tesseral, isometric) **crystal system**
- 1 tetrahedron (four-faced polyhedron) [tetrahedrite, fahlerz, fahl ore]
 - 2 hexahedron (cube, six-faced polyhedron), a holohedron [rock salt]
 - 3 centre (*Am.* center) of symmetry (crystal centre)
 - 4 axis of symmetry (rotation axis)
 - 5 plane of symmetry
 - 6 octahedron (eight-faced polyhedron) [gold]
 - 7 rhombic dodecahedron [garnet]
 - 8 pentagonal dodecahedron [pyrite, iron pyrites]
 - 9 pentagon (five-sided polygon)
 - 10 triakis-octahedron [diamond]
 - 11 icosahedron (twenty-faced polyhedron), a regular polyhedron
 - 12 icositetrahedron (twenty-four-faced polyhedron) [leucite]
 - 13 hexakis-octahedron (hexoctahedron, forty-eight-faced polyhedron) [diamond]
 - 14 octahedron with cube [galena]
 - 15 hexagon (six-sided polygon)
 - 16 cube with octahedron [fluorite, fluorspar]
 - 17 octagon (eight-sided polygon)
- 18, 19 tetragonal crystal system**
- 18 tetragonal dipyramid (tetragonal bipyramid)
 - 19 protoprism with protopyramid [zircon]
- 20-22 hexagonal crystal system**
- 20 protoprism with protopyramid, deutero-pyramid and basal pinacoid [apatite]
 - 21 hexagonal prism
 - 22 hexagonal (ditrigonal) biprism with rhombohedron [calcite]
- 23 orthorhombic pyramid (rhombic crystal system) [sulphur, *Am.* sulfur]
- 24, 25 monoclinic crystal system**
- 24 monoclinic prism with clinopinacoid and hemipyramid (hemi-hedron) [gypsum]
 - 25 orthopinacoid (swallowtail twin crystal) [gypsum]
- 26 triclinic pinacoids** (triclinic crystal system) [copper sulphate, *Am.* copper sulfate]
- 27-33 apparatus for measuring crystals** (for crystallography)
- 27 contact goniometer
 - 28 reflecting goniometer
 - 29 crystal
 - 30 collimator
 - 31 observation telescope
 - 32 divided circle (graduated circle)
 - 33 lens for reading the angle of rotation

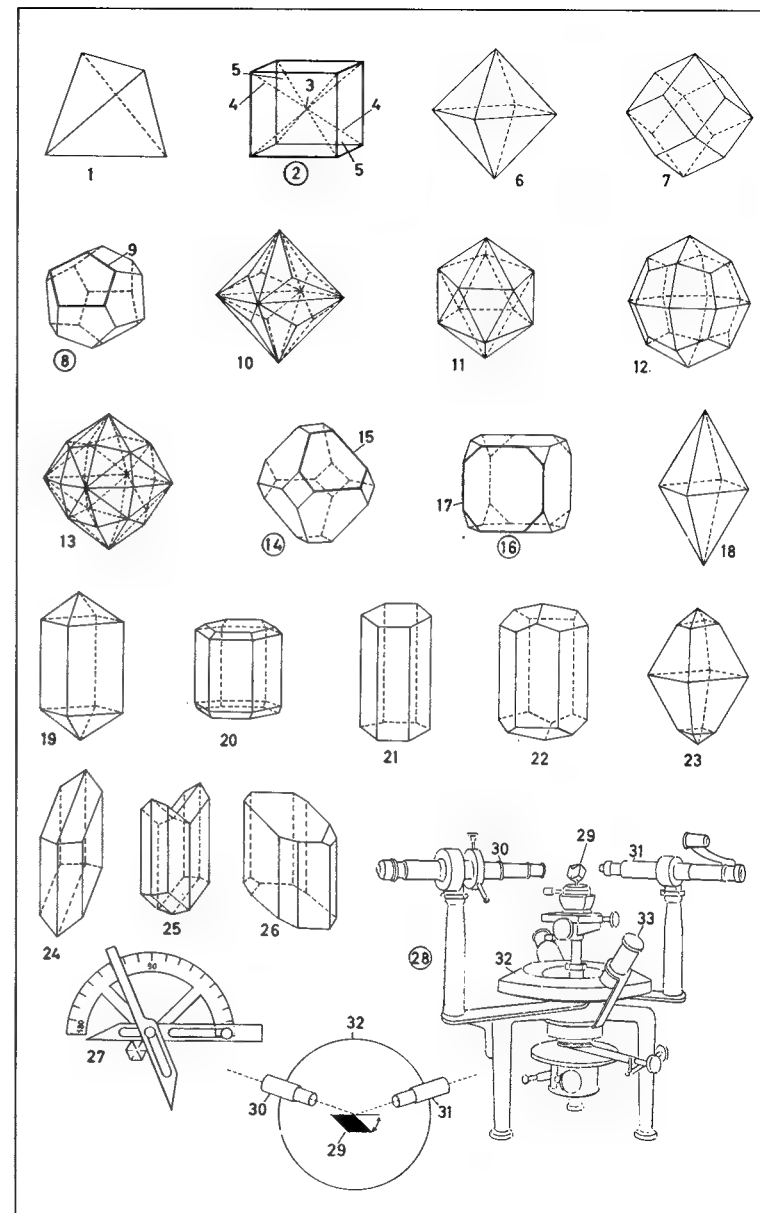

- 1 totem pole
- 2 totem, a carved and painted pictorial or symbolic representation
- 3 plains Indian
- 4 mustang, a prairie horse
- 5 lasso, a long throwing-rope with running noose
- 6 pipe of peace
- 7 wigwam (tepee, teepee)
- 8 tent pole
- 9 smoke flap
- 10 squaw, an Indian woman
- 11 Indian chief
- 12 headdress, an ornamental feather headdress
- 13 war paint
- 14 necklace of bear claws
- 15 scalp (cut from enemy's head), a trophy
- 16 tomahawk, a battle axe (*Am. ax*)
- 17 leggings
- 18 moccasin, a shoe of leather and bast
- 19 canoe of the forest Indians
- 20 Maya temple, a stepped pyramid
- 21 mummy
- 22 quipa (knotted threads, knotted code of the Incas)
- 23 Indio (Indian of Central and South America); *here*: highland Indian
- 24 poncho, a blanket with a head opening used as an armless cloak-like wrap
- 25 Indian of the tropical forest
- 26 blowpipe
- 27 quiver
- 28 dart
- 29 dart point
- 30 shrunken head, a trophy
- 31 bola (bolas), a throwing and entangling device
- 32 leather-covered stone or metal ball
- 33 pile dwelling
- 34 duk-duk dancer, a member of a duk-duk (men's secret society)

- 35 outrigger canoe (canoe with outrigger)
- 36 outrigger
- 37 Australian aborigine
- 38 loincloth of human hair
- 39 boomerang, a wooden missile
- 40 throwing stick (spear thrower) with spears

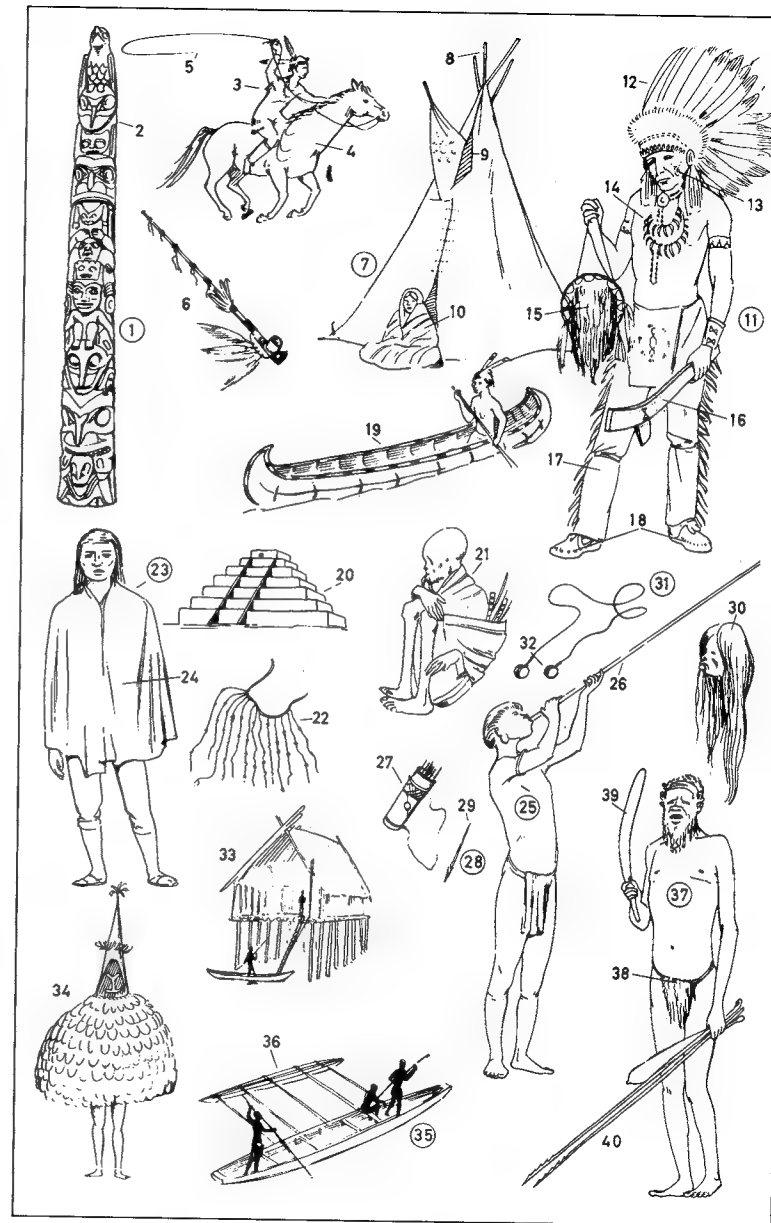

- 1 Eskimo
- 2 sledge dog (sled dog), a husky
- 3 dog sledge (dog sled)
- 4 igloo, a dome-shaped snow hut
- 5 block of snow
- 6 entrance tunnel
- 7 blubber-oil lamp
- 8 wooden missile
- 9 lance
- 10 harpoon
- 11 skin float
- 12 kayak, a light one-man canoe
- 13 skin-covered wooden or bone frame
- 14 paddle
- 15 reindeer harness
- 16 reindeer
- 17 Ostyak (Ostiak)
- 18 passenger sledge
- 19 yurt (yurta), a dwelling tent of the western and central Asiatic nomads
- 20 felt covering
- 21 smoke outlet
- 22 Kirghiz
- 23 sheepskin cap
- 24 shaman
- 25 decorative fringe
- 26 frame drum
- 27 Tibetan
- 28 flintlock with bayonets
- 29 prayer wheel
- 30 felt boot
- 31 houseboat (sampan)
- 32 junk
- 33 mat sail
- 34 rickshaw (ricksha)
- 35 rickshaw coolie (cooly)
- 36 Chinese lantern
- 37 samurai
- 38 padded armour (*Am.* armor)
- 39 geisha
- 40 kimono
- 41 obi
- 42 fan
- 43 coolie (cooly)
- 44 kris (creese, crease), a Malayan dagger
- 45 snake charmer
- 46 turban
- 47 flute
- 48 dancing snake



- 1 camel caravan
- 2 riding animal
- 3 pack animal
- 4 oasis
- 5 grove of palm trees
- 6 bedouin (beduin)
- 7 burnous
- 8 Masai warrior
- 9 headdress (hairdress)
- 10 shield
- 11 painted ox hide
- 12 long-bladed spear
- 13 negro
- 14 dance drum
- 15 throwing knife
- 16 wooden mask
- 17 figure of an ancestor
- 18 slit gong
- 19 drumstick
- 20 dugout, a boat hollowed out of a tree trunk
- 21 negro hut
- 22 negress
- 23 lip plug (labret)
- 24 grinding stone
- 25 Herero woman
- 26 leather cap
- 27 calabash (gourd)
- 28 beehive-shaped hut
- 29 bushman
- 30 earplug
- 31 loincloth
- 32 bow
- 33 knobkerry (knobkerrie), a club with round, knobbed end
- 34 bushman woman making a fire by twirling a stick
- 35 windbreak
- 36 Zulu in dance costume
- 37 dancing stick
- 38 bangle
- 39 ivory war horn
- 40 string of amulets and bones
- 41 pigmy
- 42 magic pipe for exorcising evil spirits
- 43 fetish



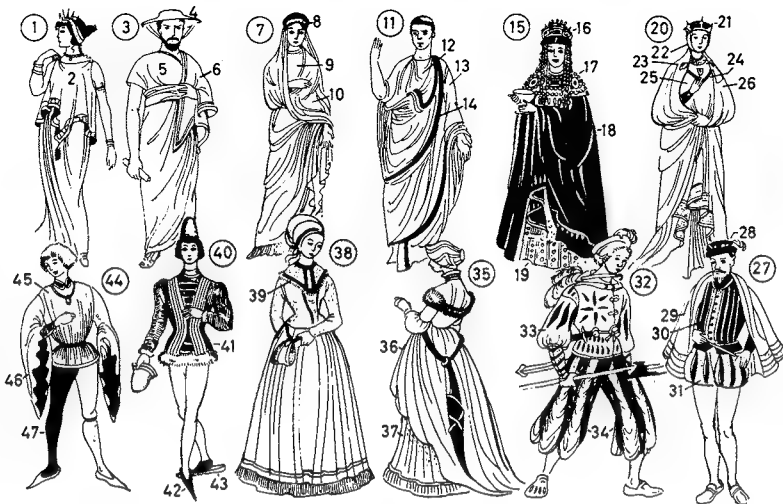

- | | |
|---|---|
| 1 Greek woman | 24 cloak cord |
| 2 peplos | 25 girt-up gown (girt-up surcoat, girt-up tunic) |
| 3 Greek | 26 cloak |
| 4 petasus (Thessalonian hat) | 27 German dressed in the Spanish style [ca. 1575] |
| 5 chiton, a linen gown worn as a basic garment | 28 wide-brimmed cap |
| 6 himation, woollen (<i>Am.</i> woolen) cloak | 29 short cloak (Spanish cloak, short cape) |
| 7 Roman woman | 30 padded doublet (stuffed doublet, peasecod) |
| 8 toupee wig (partial wig) | 31 stuffed trunk-hose |
| 9 stola | 32 lansquenet (German mercenary soldier) [ca. 1530] |
| 10 palla, a coloured (<i>Am.</i> colored) wrap | 33 slashed doublet (paned doublet) |
| 11 Roman | 34 Pluderhose (loose breeches, paned trunk-hose, slops) |
| 12 tunica (tunic) | 35 woman of Basle [ca. 1525] |
| 13 toga | 36 overgown (gown) |
| 14 purple border (purple band) | 37 undergown (petticoat) |
| 15 Byzantine empress | 38 woman of Nuremberg [ca. 1500] |
| 16 pearl diadem | 39 shoulder cape |
| 17 jewels | 40 Burgundian [15th cent.] |
| 18 purple cloak | 41 short doublet |
| 19 long tunic | |
| 20 German princess [13th cent.] | |
| 21 crown (diadem) | |
| 22 chinband | |
| 23 tassel | |



- | | |
|---|--|
| 42 piked shoes (peaked shoes, copped shoes, crackowes, poulaines) | 62 three-cornered hat |
| 43 pattens (clogs) | 63 dress sword |
| 44 young nobleman [ca. 1400] | 64 lady [ca. 1700] |
| 45 short, padded doublet (short, quilted doublet, jerkin) | 65 lace fontange (high headdress of lace) |
| 46 dagged sleeves (petal-scalloped sleeves) | 66 lace-trimmed loose-hanging gown (loose-fitting housecoat, robe de chambre, negligée, contouche) |
| 47 hose | 67 band of embroidery |
| 48 Augsburg patrician lady [ca. 1575] | 68 lady [ca. 1880] |
| 49 puffed sleeve | 69 bustle |
| 50 overgown (gown, open gown, sleeveless gown) | 70 lady [ca. 1858] |
| 51 French lady [ca. 1600] | 71 poke bonnet |
| 52 millstone ruff (cartwheel ruff, ruff) | 72 crinoline |
| 53 corseted waist (wasp waist) | 73 gentleman of the Biedermeier period |
| 54 gentleman [ca. 1650] | 74 high collar (choker collar) |
| 55 wide-brimmed felt hat (cavalier hat) | 75 embroidered waistcoat (vest) |
| 56 falling collar (wide-falling collar) of linen | 76 frock coat |
| 57 white lining | 77 pigtail wig |
| 58 jack boots (bucket-top boots) | 78 ribbon (bow) |
| 59 lady [ca. 1650] | 79 ladies in court dress [ca. 1780] |
| 60 full puffed sleeves (puffed sleeves) | 80 train |
| 61 gentleman [ca. 1700] | 81 upswept Rococo coiffure |
| | 82 hair decoration |
| | 83 panniered overskirt |

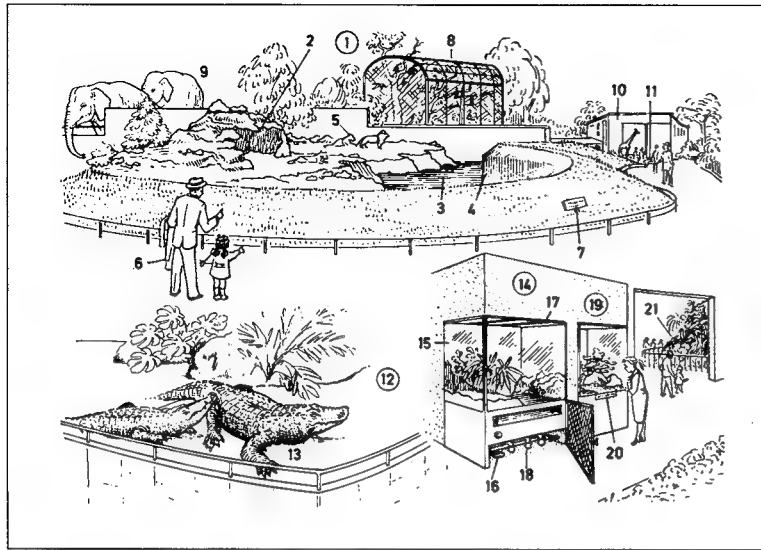

- 1 outdoor enclosure
- 2 rocks
- 3 moat
- 4 enclosing wall
- 5 animals on show; *here*: a pride of lions
- 6 visitor to the zoo
- 7 notice
- 8 aviary
- 9 elephant enclosure
- 10 animal house (*e.g.* carnivore house, giraffe house, elephant house, monkey house)
- 11 outside cage (summer quarters)
- 12 reptile enclosure
- 13 Nile crocodile
- 14 terrarium and aquarium
- 15 glass case
- 16 fresh-air inlet
- 17 ventilator
- 18 underfloor heating
- 19 aquarium
- 20 information plate
- 21 flora in artificially maintained climate

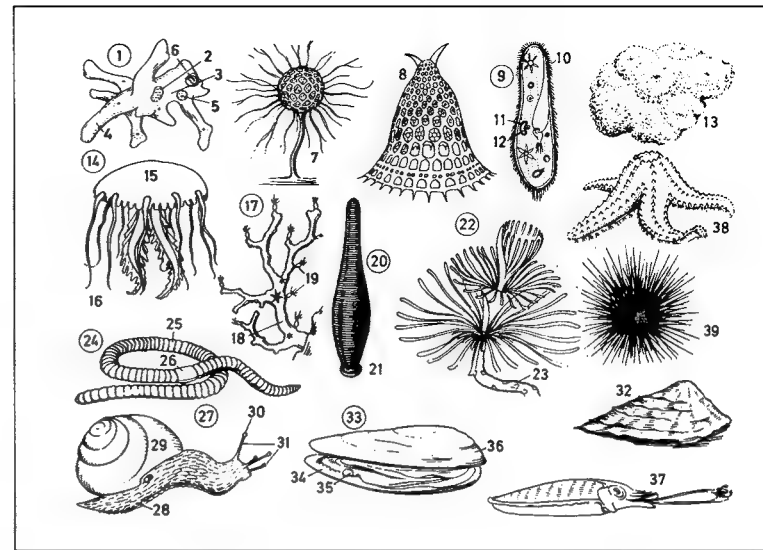

- 1-12 **unicellular** (one-celled, single-celled) **animals** (protozoans)
- 1 amoeba, a rhizopod
- 2 cell nucleus
- 3 protoplasm
- 4 pseudopod
- 5 excretory vacuole (contractile vacuole, an organelle)
- 6 food vacuole
- 7 Actinophrys, a heliozoan
- 8 radiolarian; *here*: siliceous skeleton
- 9 slipper animalcule, a Paramecium (ciliate infusorian)
- 10 cilium
- 11 macronucleus (meganucleus)
- 12 micronucleus
- 13-39 **multicellular animals** (metazoans)
- 13 bath sponge, a porifer (sponge)
- 14 medusa, a discomedusa, a coelenterate
- 15 umbrella
- 16 tentacle
- 17 red coral (precious coral), a coral animal (anthozoan, reef-building animal)
- 18 coral colony
- 19 coral polyp
- 20-26 worms (Vermes)
- 20 leech, an annelid
- 21 sucker
- 22 Spirographis, a bristle worm
- 23 tube
- 24 earthworm
- 25 segment
- 26 clitellum [accessory reproductive organ]
- 27-36 molluscs (*Am.* mollusks)
- 27 edible snail, a snail
- 28 creeping foot
- 29 shell (snail shell)
- 30 stalked eye
- 31 tentacles (feelers)
- 32 oyster
- 33 freshwater pearl mussel
- 34 mother-of-pearl (nacre)
- 35 pearl
- 36 mussel shell
- 37 cuttlefish, a cephalopod
- 38, 39 echinoderms
- 38 starfish (sea star)
- 39 sea urchin (sea hedgehog)

- 1, 2 crustaceans**
 1 mitten crab, a crab
 2 water slater
3-39, 48-56 insects
 3 water nymph (dragonfly), a homopteran (homopterous insect)
 4 water scorpion (water bug), a rhynchophore
 5 raptorial leg
 6 mayfly (dayfly, ephemerid)
 7 compound eye
 8 green grasshopper (green locust, meadow grasshopper), an orthopteron (orthopterous insect)
 9 larva (grub)
 10 adult insect, an imago
 11 leaping hind leg
 12 caddis fly (spring fly, water moth), a neuropteran
 13 aphid (greenfly), a plant louse
 14 wingless aphid
 15 winged aphid
16-20 dipterous insects (dipterans)
 16 gnat (mosquito, midge), a culicid
 17 proboscis (sucking organ)
 18 bluebottle (blowfly), a fly
 19 maggot (larva)
 20 chrysalis (pupa)
21-23 Hymenoptera
 21, 22 ant
 21 winged female
 22 worker
 23 bumblebee (humblebee)
24-39 beetles (Coleoptera)
 24 stag beetle, a lamellicorn beetle
 25 mandibles
 26 trophi
 27 antenna (feeler)
 28 head
 29, 30 thorax
 29 thoracic shield (prothorax)
 30 scutellum
 31 tergites
 32 stigma
 33 wing (hind wing)
 34 nervure
 35 point at which the wing folds

- 36 elytron (forewing)
 37 ladybird (*Am. ladybug*), a coccinellid
 38 *Ergates faber*, a longicorn beetle (longicorn)
 39 dung beetle, a lamellicorn beetle
40-47 arachnids
 40 *Euscorpium flavicandus*, a scorpion
 41 cheliped with chelicer
 42 maxillary antenna (maxillary feeler)
 43 tail sting
44-46 spiders
 44 wood tick (dog tick)
 45 cross spider (garden spider), an orb spinner
 46 spinneret
 47 spider's web (web)
48-56 Lepidoptera (butterflies and moths)
 48 mulberry-feeding moth (silk moth), a bombycid moth
 49 eggs
 50 silkworm
 51 cocoon
 52 swallowtail, a butterfly
 53 antenna (feeler)
 54 eyespot
 55 privet hawkmoth, a hawkmoth (sphinx)
 56 proboscis

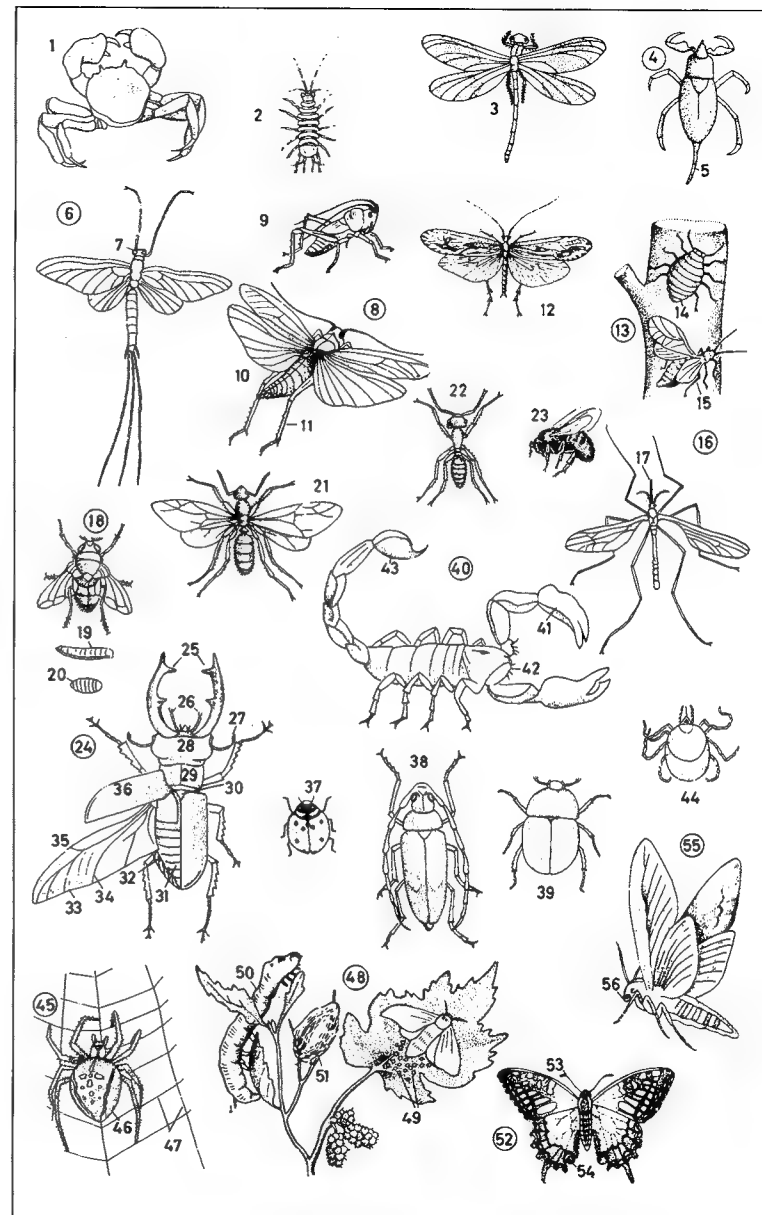

1-3 flightless birds

- 1 cassowary; *sim.*: emu
 2 ostrich
 3 clutch of ostrich eggs [12 - 14 eggs]
 4 king penguin, a penguin, a flightless bird

5-10 web-footed birds

- 5 white pelican
 6 webfoot (webbed foot)
 7 web (palmations) of webbed foot (palmate foot)
 8 lower mandible with gular pouch
 9 northern gannet (gannet, solan goose), a gannet
 10 green cormorant (shag), a cormorant displaying with spread wings

11-14 long-winged birds (seabirds)

- 11 common sea swallow, a sea swallow (tern), diving for food
 12 fulmar
 13 guillemot, an auk
 14 black-headed gull (mire crow), a gull

15-17 Anseres

- 15 goosander (common merganser), a sawbill
 16 mute swan, a swan
 17 knob on the bill
 18 common heron, a heron

19-21 plovers

- 19 stilt (stilt bird, stilt plover)
 20 coot, a rail
 21 lapwing (green plover, peewit, pewit)

- 22 quail, a gallinaceous bird

- 23 turtle dove, a pigeon

- 24 swift

- 25 hoopoe, a roller

- 26 erectile crest

- 27 spotted woodpecker, a woodpecker; *related*: wryneck

- 28 entrance to the nest

- 29 nesting cavity

- 30 cuckoo

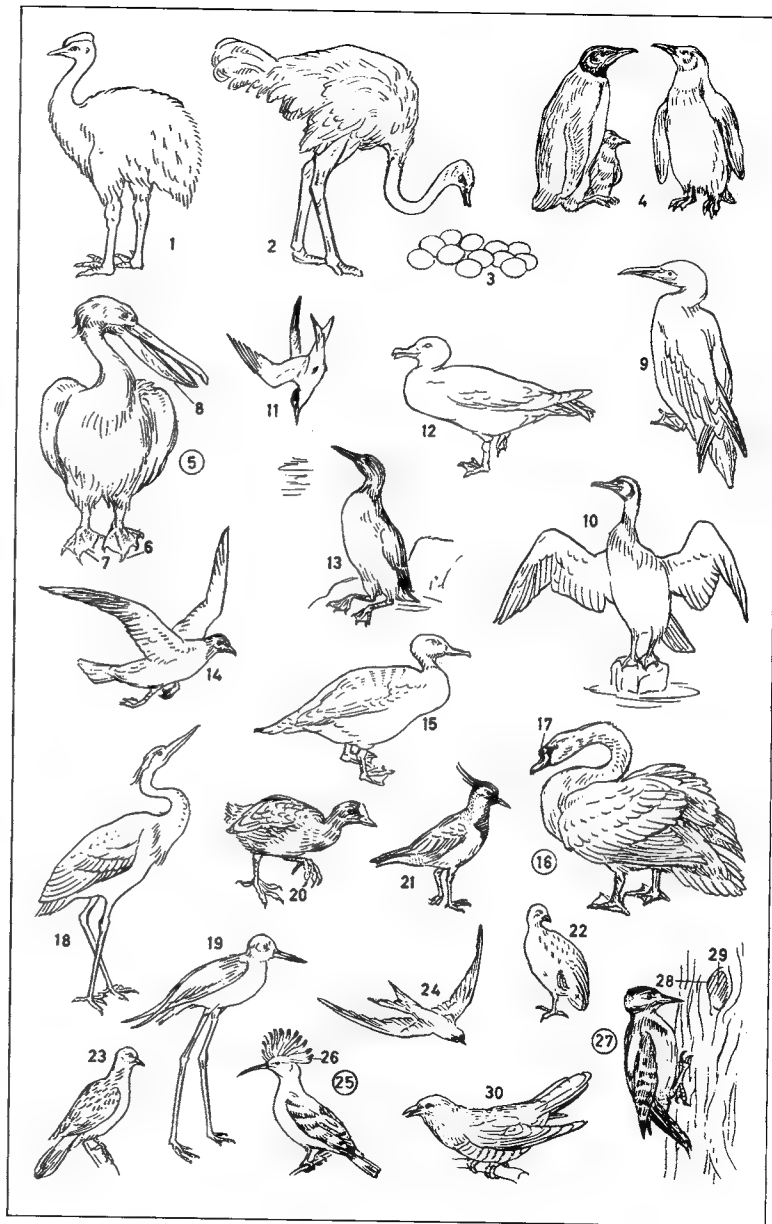

1, 3, 4, 5, 7, 9, 10 songbirds

1 goldfinch, a finch

2 bee eater

3 redstart (star finch), a thrush

4 bluetit, a tit (titmouse), a resident
bird (non-migratory bird)

5 bullfinch

6 common roller (roller)

7 golden oriole, a migratory bird

8 kingfisher

9 white wagtail, a wagtail

10 chaffinch

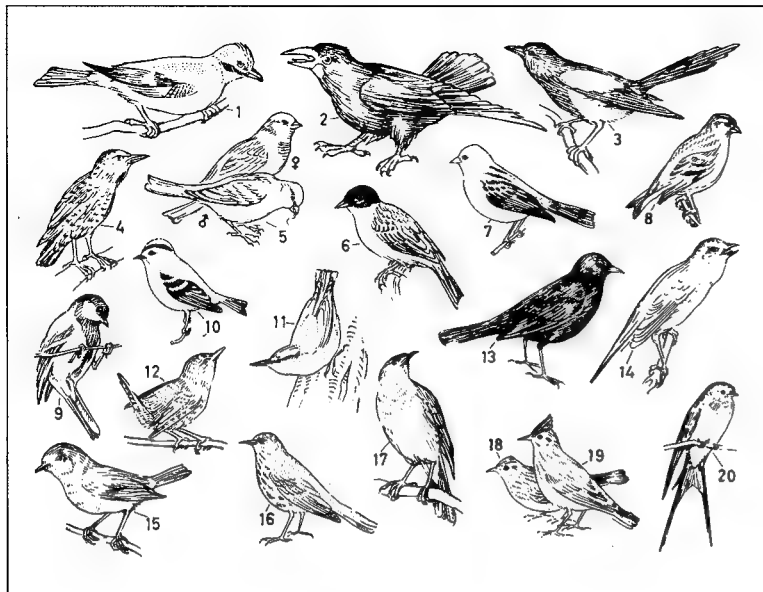

**1-20 songbirds****1-3 Corvidae** (corvine birds, crows)

1 jay (nutcracker)

2 rook, a crow

3 magpie

4 starling (pastor, shepherd bird)

5 house sparrow

6-8 finches

6, 7 buntings

6 yellowhammer (yellow bunting)

7 ortolan (ortolan bunting)

8 siskin (aberdevine)

9 great titmouse (great tit, ox eye), a titmouse (tit)

10 golden-crested wren (goldcrest);
sim.: firecrest, one of the
Regulidae

11 nuthatch

12 wren

13-17 thrushes

13 blackbird

14 nightingale (*poet.*: philomel,
philomela)

15 robin (redbreast, robin redbreast)

16 song thrush (throstle, mavis)

17 thrush nightingale

18, 19 larks

18 woodlark

19 crested lark (tufted lark)

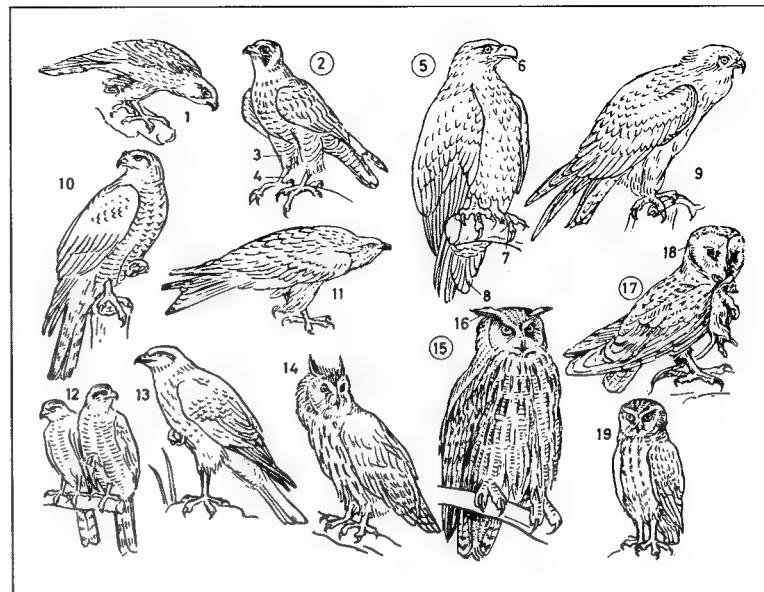
20 common swallow (barn swallow,
chimney swallow), a swallow**1-13 diurnal birds of prey****1-4 falcons**

1 merlin

2 peregrine falcon

3 leg feathers

4 tarsus

5-9 eagles5 white-tailed sea eagle (white-tailed
eagle, grey sea eagle, erne)

6 hooked beak

7 claw (talon)

8 tail

9 common buzzard

10-13 accipiters

10 goshawk

11 common European kite (glede,
kite)

12 sparrow hawk (spar-hawk)

13 marsh harrier (moor buzzard,
moor harrier, moor hawk)**14-19 owls**

14 long-eared owl (horned owl)

15 eagle-owl (great horned owl)

16 plumicorn (feathered ear, ear tuft,
ear, horn)17 barn owl (white owl, silver owl,
yellow owl, church owl, screech
owl)

18 facial disc (disk)

19 little owl (sparrow owl)

- 1 sulphur-crested cockatoo, a parrot
- 2 blue-and-yellow macaw
- 3 blue bird of paradise
- 4 sappho
- 5 cardinal (cardinal bird)
- 6 toucan (red-billed toucan), one of the Piciformes



1-18 fishes

- 1 man-eater (blue shark, requin), a shark
 2 nose (snout)
 3 gill slit (gill cleft)
 4 mirror carp
 5 gill cover (operculum)
 6 dorsal fin
 7 pectoral fin
 8 pelvic fin (abdominal fin, ventral fin)
 9 anal fin
 10 caudal fin (tail fin)
 11 scale
 12 catfish (sheatfish, sheathfish, wels)
 13 barbel
 14 herring
 15 brown trout
 16 pike (northern pike)
 17 freshwater eel (eel)
 18 sea horse (Hippocampus, horsefish)

19 tufted gills**20-26 Amphibia (amphibians)**

- 20-22 salamanders
 20 greater water newt (crested newt),
 ■ water newt
 21 dorsal crest
 22 fire salamander, a salamander
 23-26 salientians (anurans, batrachians)
 23 European toad, a toad
 24 tree frog (tree toad)
 25 vocal sac (vocal pouch, croaking sac)
 26 adhesive disc (disk)

27-41 reptiles

- 27, 30-37 lizards
 27 sand lizard
 28 hawksbill turtle (hawksbill)
 29 carapace (shell)
 30 basilisk
 31 desert monitor, a monitor lizard (monitor)
 32 common iguana, an iguana
 33 chameleon, one of the Chamaeleontidae (Rhipitoglossa)
 34 prehensile foot

35 prehensile tail

- 36 wall gecko, a gecko
 37 slowworm (blindworm), one of the Anguidae
38-41 snakes
 38 ringed snake (ring snake, water snake, grass snake), a colubrid
 39 collar
 40, 41 vipers (adders)
 40 common viper, a poisonous (venomous) snake
 41 asp (asp viper)

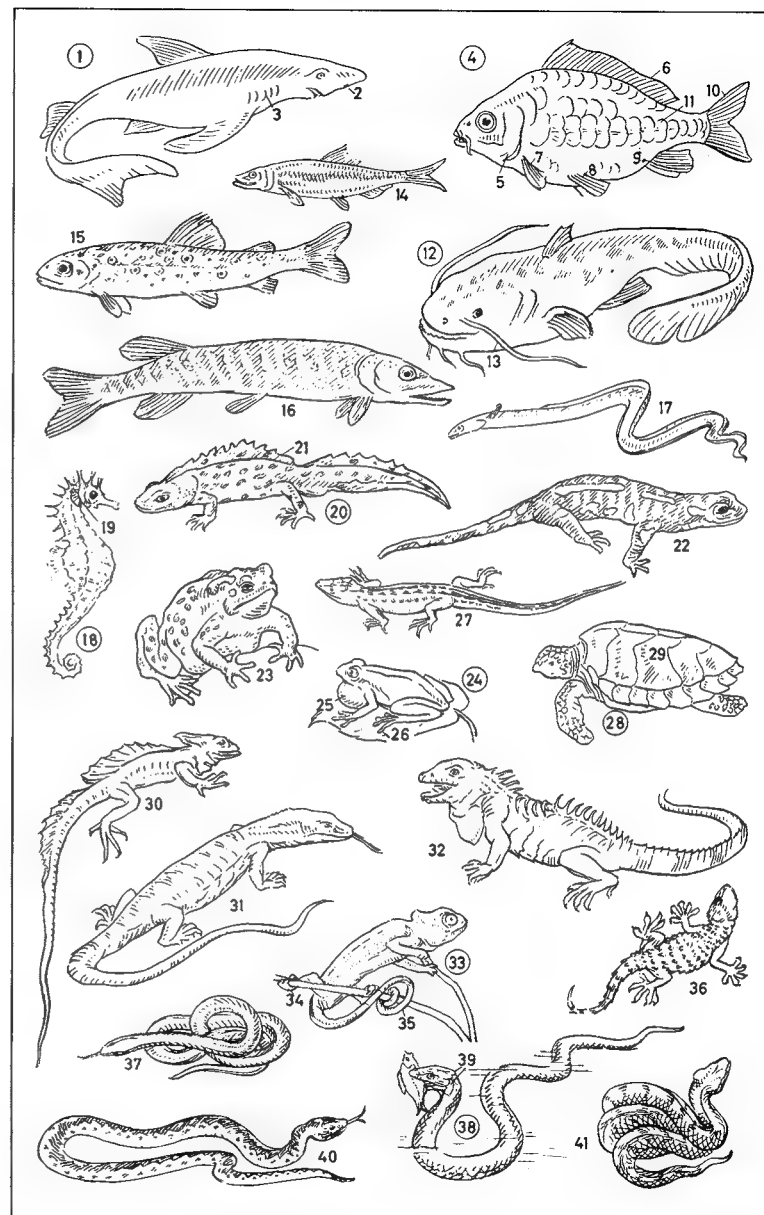

1-6 butterflies

- 1 red admiral
- 2 peacock butterfly
- 3 orange tip (orange tip butterfly)
- 4 brimstone (brimstone butterfly)
- 5 Camberwell beauty (mourning cloak, mourning cloak butterfly)
- 6 blue (lycaenid butterfly, lycaenid)

7-11 moths (Heterocera)

- 7 garden tiger
- 8 red underwing
- 9 death's-head moth (death's-head hawkmoth), a hawkmoth (sphinx)
- 10 caterpillar
- 11 chrysalis (pupa)



- 1 platypus (duck-bill, duck-mole), a monotreme (oviparous mammal)
 2, 3 marsupial mammals (marsupials)
 2 New World opossum, a didelphid
 3 red kangaroo (red flyer), a kangaroo
 4-7 insectivores (insect-eating mammals)
 4 mole
 5 hedgehog
 6 spine
 7 shrew (shrew mouse), one of the Soricidae
 8 nine-banded armadillo (peba)
 9 long-eared bat (flutter-mouse), a flying mammal (chiropter, chiropteran)
 10 pangolin (scaly ant-eater), a scaly mammal
 11 two-toed sloth (unau)
 12-19 rodents
 12 guinea pig (cavy)
 13 porcupine
 14 beaver
 15 jerboa
 16 hamster
 17 water vole
 18 marmot
 19 squirrel
 20 African elephant, a proboscidean (proboscidian)
 21 trunk (proboscis)
 22 tusk
 23 manatee (manati, lamantin), a sirenian
 24 South African dassie (das, coney, hyrax), a procaviid
 25-31 ungulates
 25-27 odd-toed ungulates
 25 African black rhino, a rhinoceros (nasicorn)
 26 Brazilian tapir, a tapir
 27 zebra
 28-31 even-toed ungulates
 28-30 ruminants
 28 llama
 29 Bactrian camel (two-humped camel)
 30 guanaco
 31 hippopotamus

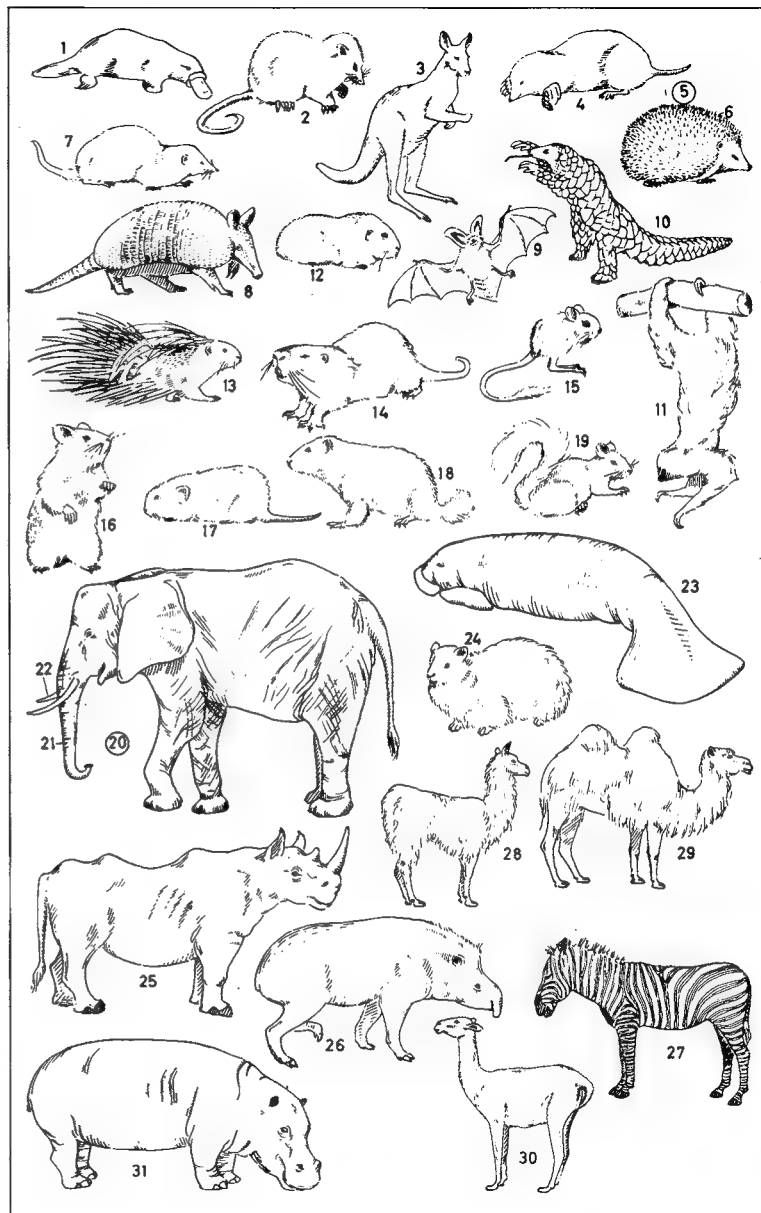

1-10 ungulates, ruminants

- 1 elk (moose)
- 2 wapiti (*Am. elk*)
- 3 chamois
- 4 giraffe
- 5 black buck, an antelope
- 6 mouflon (mouflon)
- 7 ibex (rock goat, bouquetin, steinbock)
- 8 water buffalo (Indian buffalo, water ox)
- 9 bison
- 10 musk ox

11-22 carnivores (beasts of prey)**11-13 Canidae**

- 11 black-backed jackal (jackal)
- 12 red fox
- 13 wolf

14-17 martens

- 14 stone marten (beach marten)
- 15 sable
- 16 weasel
- 17 sea otter, an otter

18-22 seals (pinnipeds)

- 18 fur seal (sea bear, ursine seal)
- 19 common seal (sea calf, sea dog)
- 20 walrus (morse)
- 21 whiskers
- 22 tusk

23-29 whales

- 23 bottle-nosed dolphin (bottle-nose dolphin)
- 24 common dolphin
- 25 sperm whale (cachalot)
- 26 blowhole (spout hole)
- 27 dorsal fin
- 28 flipper
- 29 tail flukes (tail)

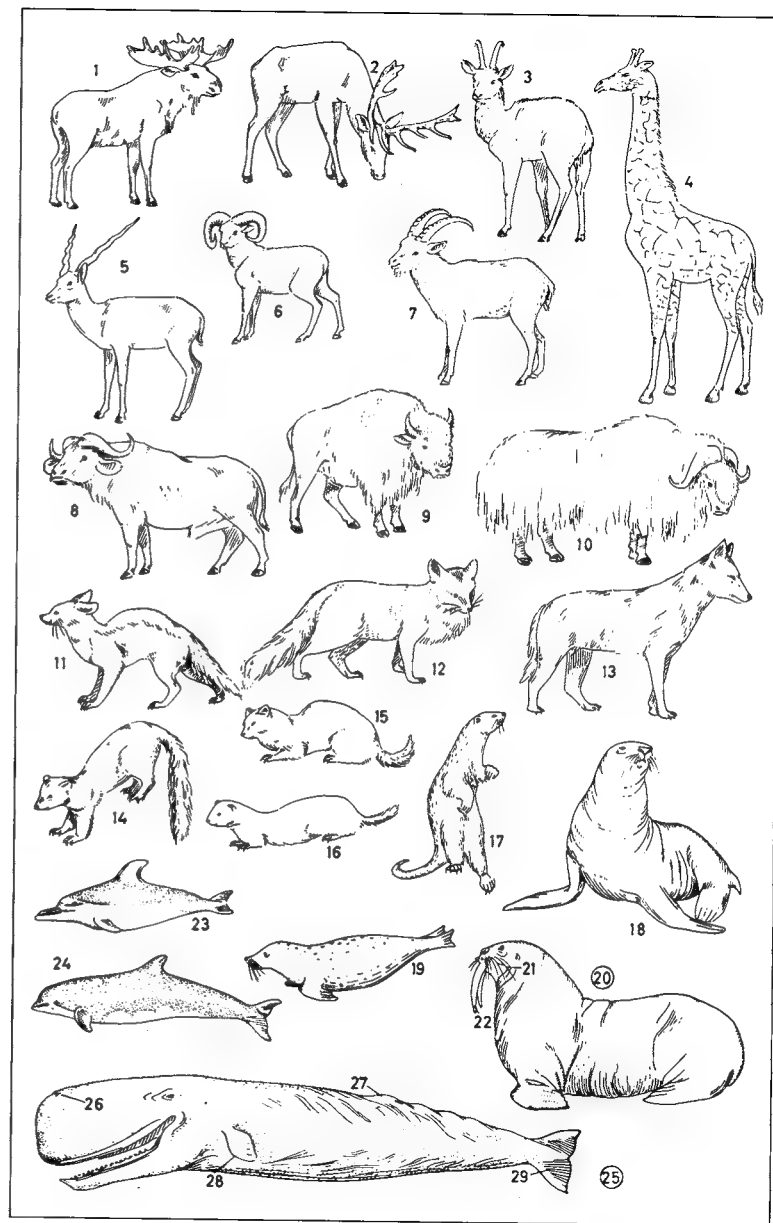

1-11 carnivores (beasts of prey)

1 striped hyena, a hyena

2-8 felines (cats)

2 lion

3 mane (lion's mane)

4 paw

5 tiger

6 leopard

7 cheetah (hunting leopard)

8 lynx

9-11 bears9 raccoon (raccoon, *Am. coon*)

10 brown bear

11 polar bear (white bear)

12-16 primates

12, 13 monkeys

12 rhesus monkey (rhesus, rhesus macaque)

13 baboon

14-16 anthropoids (anthropoid apes, great apes)

14 chimpanzee

15 orang-utan (orang-outan)

16 gorilla

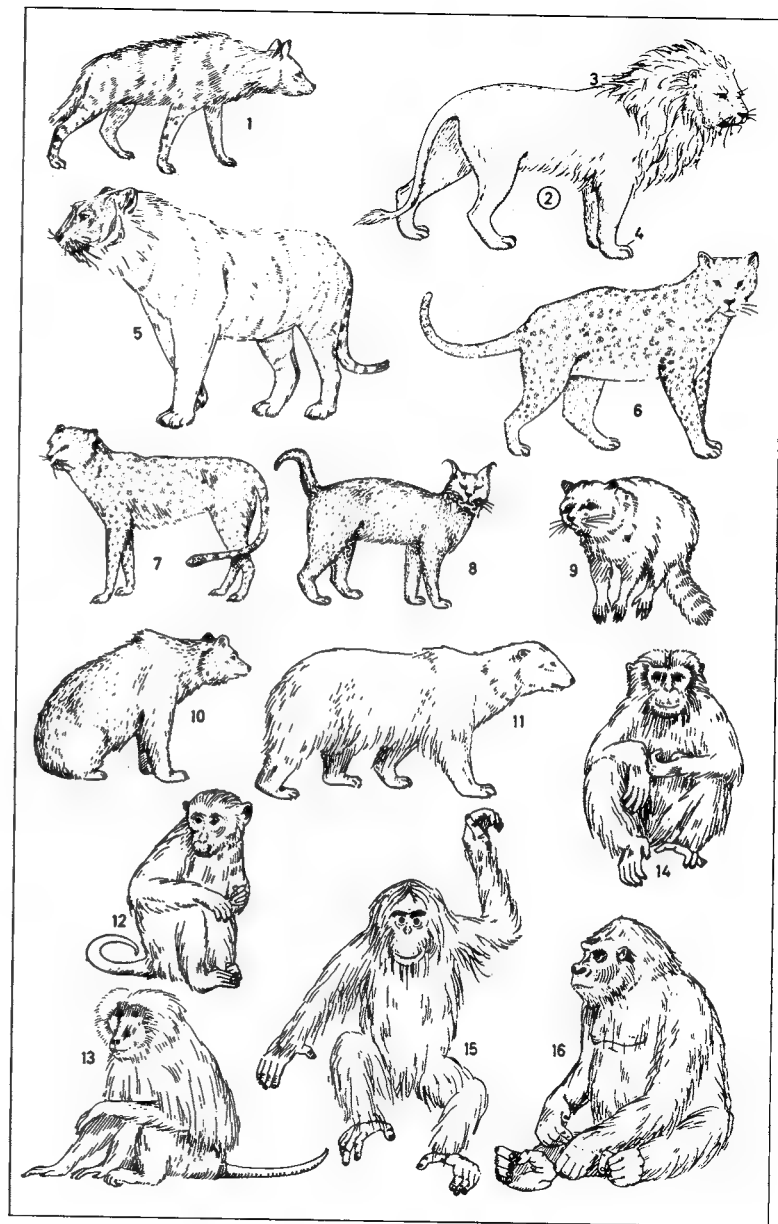



- 1 *Gigantocypris agassizi*
- 2 *Eupharynx pelecyanoides* (pelican eel, pelican fish)
- 3 *Metacrinus* (feather star), a sea lily, an echinoderm
- 4 *Lycoteuthis diadema* (jewelled squid), a cuttlefish [luminescent]
- 5 *Atolla*, a deep-sea medusa, a coelenterate
- 6 *Melanocetes*, a pediculate [luminescent]
- 7 *Lophocalyx philippensis*, a glass sponge
- 8 *Mopsea*, a sea fan [colony]
- 9 *Hydrallmania*, a hydroid polyp, a coelenterate [colony]
- 10 *Malacosteus indicus*, a stomiatid [luminescent]
- 11 *Brisinga endecacnemos*, a sand star (brittle star), an echinoderm [luminescent only when stimulated]
- 12 *Pasiphaea*, a shrimp, a crustacean
- 13 *Echiostoma*, a stomiatid, a fish [luminescent]
- 14 *Umbellula encrinus*, a sea pen (sea feather), a coelenterate [colony, luminescent]
- 15 *Polycheles*, a crustacean
- 16 *Lithodes*, a crustacean, a crab
- 17 *Archaster*, a starfish (sea star), an echinoderm
- 18 *Oneirophanta*, a sea cucumber, an echinoderm
- 19 *Palaeopneustes niasicus*, a sea urchin (sea hedgehog), an echinoderm
- 20 *Chitonactis*, a sea anemone (actinia), a coelenterate

- 1 tree
 2 bole (tree trunk, trunk, stem)
 3 crown of tree (crown)
 4 top of tree (treetop)
 5 bough (limb, branch)
 6 twig (branch)
 7 bole (tree trunk) [cross section]
 8 bark (rind)
 9 phloem (bast sieve tissue, inner fibrous bark)
 10 cambium (cambium ring)
 11 medullary rays (vascular rays, pith rays)
 12 sapwood (sap, alburnum)
 13 heartwood (duramen)
 14 pith
 15 plant
 16-18 root
 16 primary root
 17 secondary root
 18 root hair
 19-25 shoot (sprout)
 19 leaf
 20 stalk
 21 side shoot (offshoot)
 22 terminal bud
 23 flower
 24 flower bud
 25 leaf axil with axillary bud
 26 leaf
 27 leaf stalk (petiole)
 28 leaf blade (blade, lamina)
 29 venation (veins, nervures, ribs)
 30 midrib (nerve)
 31-38 leaf shapes
 31 linear
 32 lanceolate
 33 orbicular (orbiculate)
 34 acerose (acerous, acerate, acicular, needle-shaped)
 35 cordate
 36 ovate
 37 sagittate
 38 reniform
 39-42 compound leaves
 39 digitate (digitated, palmate, quinquefoliate)
 40 pinnatifid
 41 abruptly pinnate
 42 odd-pinnate
 43-50 leaf margin shapes
 43 entire
 44 serrate (serrulate, saw-toothed)
 45 doubly toothed
 46 crenate
 47 dentate
 48 sinuate
 49 ciliate (ciliated)
 50 cilium
 51 flower
 52 flower stalk (flower stem, scape)
 53 receptacle (floral axis, thalamus, torus)
 54 ovary
 55 style
 56 stigma
 57 stamen
 58 sepal
 59 petal
 60 ovary and stamen [section]
 61 ovary wall
 62 ovary cavity
 63 ovule
 64 embryo sac
 65 pollen
 66 pollen tube
 67-77 inflorescences
 67 spike (racemose spike)
 68 raceme (simple raceme)
 69 panicle
 70 cyme
 71 spadix (fleshy spike)
 72 umbel (simple umbel)
 73 capitulum
 74 composite head (discoid flower head)
 75 hollow flower head
 76 bostryx (helicoid cyme)
 77 cincinnus (scorpioid cyme, curled cyme)
 78-82 roots
 78 adventitious roots
 79 tuber (tuberous root, swollen taproot)
 80 adventitious roots (aerial roots)
 81 root thorns
 82 pneumatophores
 83-85 blade of grass
 83 leaf sheath
 84 ligule (ligula)
 85 leaf blade (lamina)
 86 embryo (seed, germ)
 87 cotyledon (seed leaf, seed lobe)
 88 radicle
 89 hypocotyl
 90 plumule (leaf bud)
 91-102 fruits
 91-96 dehiscent fruits
 91 follicle
 92 legume (pod)
 93 siliqua (pod)
 94 schizocarp
 95 pyxidium (circumscissile seed vessel)
 96 poricidal capsule (porose capsule)
 97-102 indehiscent fruits
 97 berry
 98 nut
 99 drupe (stone fruit) (cherry)
 100 aggregate fruit (compound fruit) (rose hip)
 101 aggregate fruit (compound fruit) (raspberry)
 102 pome (apple)

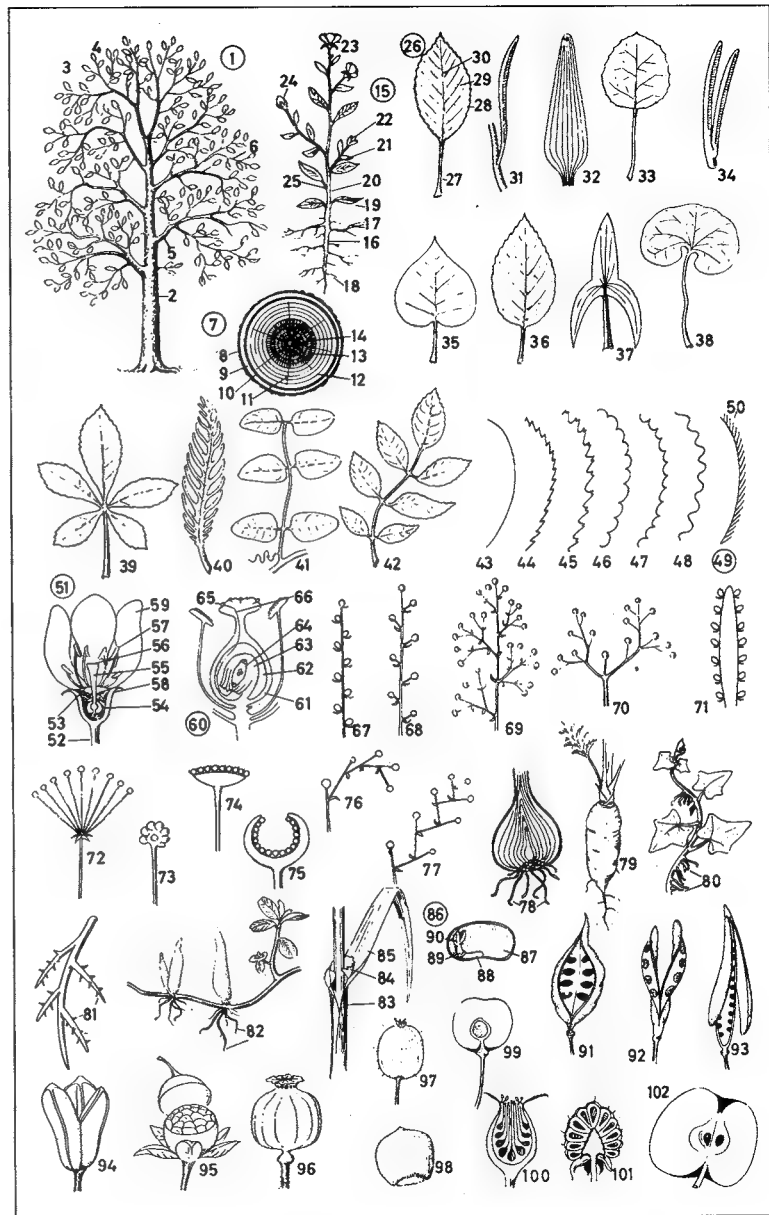

1-73 deciduous trees

- 1 oak (oak tree)
- 2 flowering branch
- 3 fruiting branch
- 4 fruit (acorn)
- 5 cupule (cup)
- 6 female flower
- 7 bract
- 8 male inflorescence
- 9 birch (birch tree)
- 10 branch with catkins, a flowering branch
- 11 fruiting branch
- 12 scale (catkin scale)
- 13 female flower
- 14 male flower
- 15 poplar
- 16 flowering branch
- 17 flower
- 18 fruiting branch
- 19 fruit
- 20 seed
- 21 leaf of the aspen (trembling poplar)
- 22 infructescence
- 23 leaf of the white poplar (silver poplar, silverleaf)
- 24 sallow (goat willow)
- 25 branch with flower buds
- 26 catkin with single flower
- 27 branch with leaves
- 28 fruit
- 29 osier branch with leaves
- 30 alder
- 31 fruiting branch
- 32 branch with previous year's cone
- 33 beech (beech tree)
- 34 flowering branch
- 35 flower
- 36 fruiting branch
- 37 beech nut
- 38 ash (ash tree)
- 39 flowering branch
- 40 flower
- 41 fruiting branch
- 42 mountain ash (rowan, quickbeam)
- 43 inflorescence

- 44 infructescence
- 45 fruit [longitudinal section]
- 46 lime (lime tree, linden, linden tree)
- 47 fruiting branch
- 48 inflorescence
- 49 elm (elm tree)
- 50 fruiting branch
- 51 flowering branch
- 52 flower
- 53 maple (maple tree)
- 54 flowering branch
- 55 flower
- 56 fruiting branch
- 57 maple seed with wings (winged maple seed)
- 58 horse chestnut (horse chestnut tree, chestnut, chestnut tree, buck-eye)
- 59 branch with young fruits
- 60 chestnut (horse chestnut)
- 61 mature (ripe) fruit
- 62 flower [longitudinal section]
- 63 hornbeam (yoke elm)
- 64 fruiting branch
- 65 seed
- 66 flowering branch
- 67 plane (plane tree)
- 68 leaf
- 69 infructescence and fruit
- 70 false acacia (locust tree)
- 71 flowering branch
- 72 part of the infructescence
- 73 base of the leaf stalk with stipules



1-71 coniferous trees (conifers)

- 1 silver fir (European silver fir, common silver fir)
- 2 fir cone, a fruit cone
- 3 cone axis
- 4 female flower cone
- 5 bract scale (bract)
- 6 male flower shoot
- 7 stamen
- 8 cone scale
- 9 seed with wing (winged seed)
- 10 seed [longitudinal section]
- 11 fir needle (needle)
- 12 spruce (spruce fir)
- 13 spruce cone
- 14 cone scale
- 15 seed
- 16 female flower cone
- 17 male inflorescence
- 18 stamen
- 19 spruce needle
- 20 pine (Scots pine)
- 21 dwarf pine
- 22 female flower cone
- 23 short shoot with bundle of two leaves
- 24 male inflorescences
- 25 annual growth
- 26 pine cone
- 27 cone scale
- 28 seed
- 29 fruit cone of the arolla pine (Swiss stone pine)
- 30 fruit cone of the Weymouth pine (white pine)
- 31 short shoot [cross section]
- 32 larch
- 33 flowering branch
- 34 scale of the female flower cone
- 35 anther
- 36 branch with larch cones (fruit cones)
- 37 seed
- 38 cone scale
- 39 arbor vitae (tree of life, thuja)
- 40 fruiting branch
- 41 fruit cone

- 42 scale
- 43 branch with male and female flowers
- 44 male shoot
- 45 scale with pollen sacs
- 46 female shoot
- 47 juniper (juniper tree)
- 48 female shoot [longitudinal section]
- 49 male shoot
- 50 scale with pollen sacs
- 51 fruiting branch
- 52 juniper berry
- 53 fruit [cross section]
- 54 seed
- 55 stone pine
- 56 male shoot
- 57 fruit cone with seeds [longitudinal section]
- 58 cypress
- 59 fruiting branch
- 60 seed
- 61 yew (yew tree)
- 62 male flower shoot and female flower cone
- 63 fruiting branch
- 64 fruit
- 65 cedar (cedar tree)
- 66 fruiting branch
- 67 fruit scale
- 68 male flower shoot and female flower cone
- 69 mammoth tree (Wellingtonia, sequoia)
- 70 fruiting branch
- 71 seed



- 1 forsythia
- 2 ovary and stamen
- 3 leaf
- 4 yellow-flowered jasmine (jasmin, jessamine)
- 5 flower [longitudinal section] with styles, ovaries, and stamens
- 6 privet (common privet)
- 7 flower
- 8 infructescence
- 9 mock orange (sweet syringa)
- 10 snowball (snowball bush, guelder rose)
- 11 flower
- 12 fruits
- 13 oleander (rosebay, rose laurel)
- 14 flower [longitudinal section]
- 15 red magnolia
- 16 leaf
- 17 japonica (japanese quince)
- 18 fruit
- 19 common box (box, box tree)
- 20 female flower
- 21 male flower
- 22 fruit [longitudinal section]
- 23 weigela (weigelia)
- 24 yucca [part of the inflorescence]
- 25 leaf
- 26 dog rose (briar rose, wild briar)
- 27 fruit
- 28 kerria
- 29 fruit
- 30 cornelian cherry
- 31 flower
- 32 fruit (cornelian cherry)
- 33 sweet gale (gale)

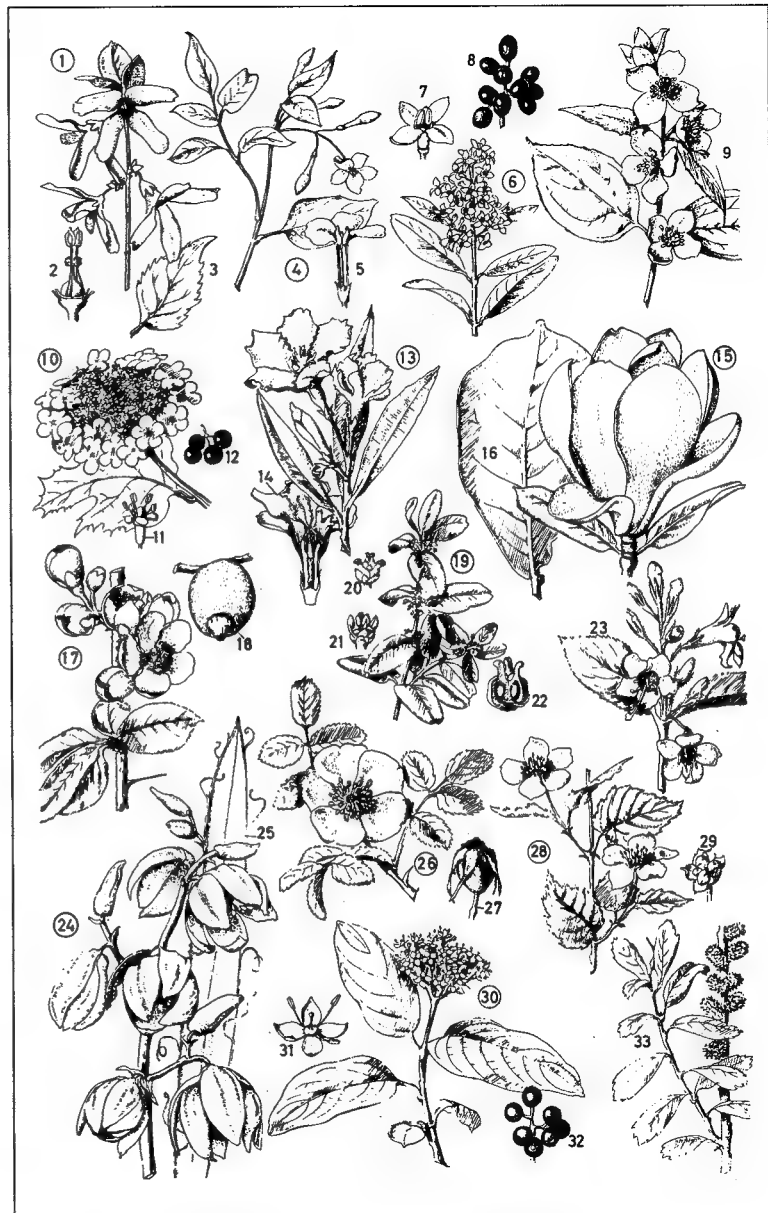

- 1 tulip tree (tulip poplar, saddle tree, whitewood)
- 2 carpels
- 3 stamen
- 4 fruit
- 5 hyssop
- 6 flower [front view]
- 7 flower
- 8 calyx with fruit
- 9 holly
- 10 androgynous (hermaphroditic, hermaphrodite) flower
- 11 male flower
- 12 fruit with stones exposed
- 13 honeysuckle (woodbine, woodbind)
- 14 flower buds
- 15 flower [cut open]
- 16 Virginia creeper (American ivy, woodbine)
- 17 open flower
- 18 infructescence
- 19 fruit [longitudinal section]
- 20 broom
- 21 flower with the petals removed
- 22 immature (unripe) legume (pod)
- 23 spiraea
- 24 flower [longitudinal section]
- 25 fruit
- 26 carpel
- 27 blackthorn (sloe)
- 28 leaves
- 29 fruits
- 30 single-pistilled hawthorn (thorn, may)
- 31 fruit
- 32 laburnum (golden chain, golden rain)
- 33 raceme
- 34 fruits
- 35 black elder (elder)
- 36 elder flowers
- 37 elderberries

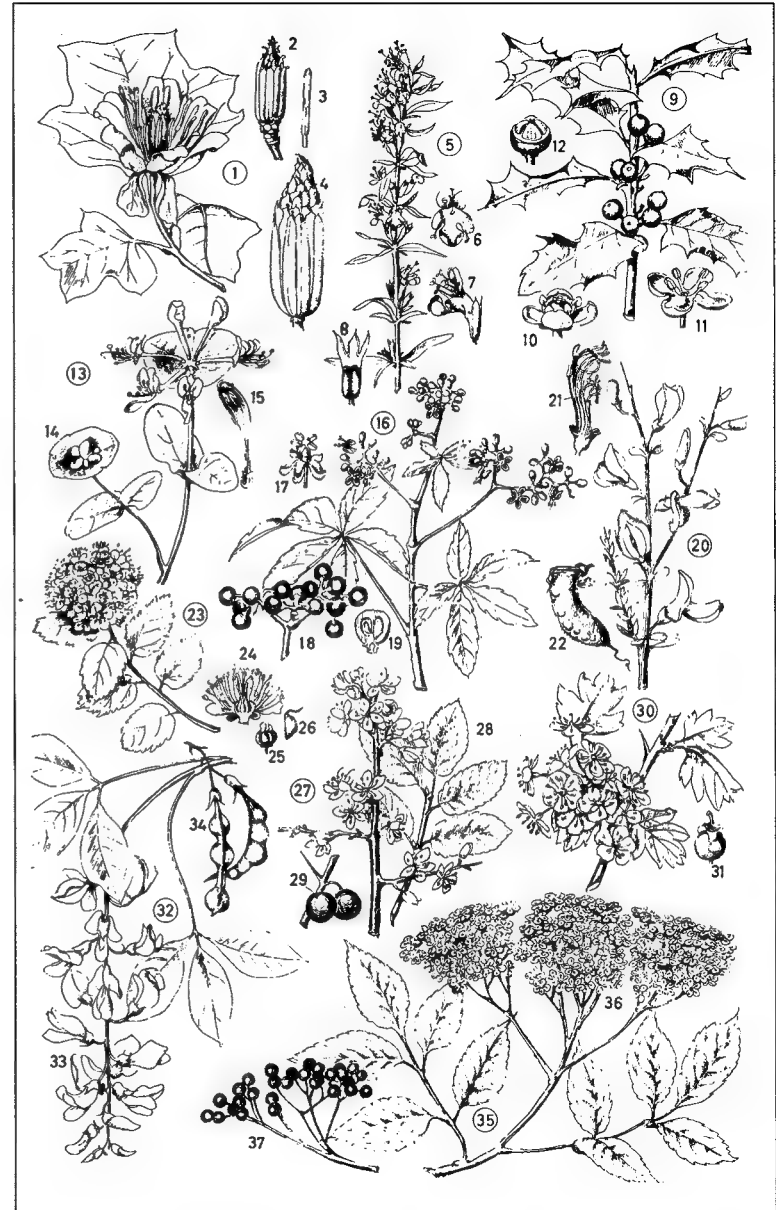

- 1 rotundifoliate (rotundifolious) saxifrage (rotundifoliate breakstone)
- 2 leaf
- 3 flower
- 4 fruit
- 5 anemone (windflower)
- 6 flower [longitudinal section]
- 7 fruit
- 8 buttercup (meadow buttercup, butterflower, goldcup, king cup, crow-foot)
- 9 basal leaf
- 10 fruit
- 11 lady's smock (ladysmock, cuckoo flower)
- 12 basal leaf
- 13 fruit
- 14 harebell (hairbell, bluebell)
- 15 basal leaf
- 16 flower [longitudinal section]
- 17 fruit
- 18 ground ivy (ale hoof)
- 19 flower [longitudinal section]
- 20 flower [front view]
- 21 stonecrop
- 22 speedwell
- 23 flower
- 24 fruit
- 25 seed
- 26 moneywort
- 27 dehiscent fruit
- 28 seed
- 29 small scabious
- 30 basal leaf
- 31 ray floret (flower of outer series)
- 32 disc (disk) floret (flower of inner series)
- 33 involucre calyx with pappus bristles
- 34 ovary with pappus
- 35 fruit
- 36 lesser celandine
- 37 fruit
- 38 leaf axil with bulbil
- 39 annual meadow grass
- 40 flower
- 41 spikelet [side view]

- 42 spikelet [front view]
- 43 caryopsis, an indehiscent fruit
- 44 tuft of grass (clump of grass)
- 45 comfrey
- 46 flower [longitudinal section]
- 47 fruit

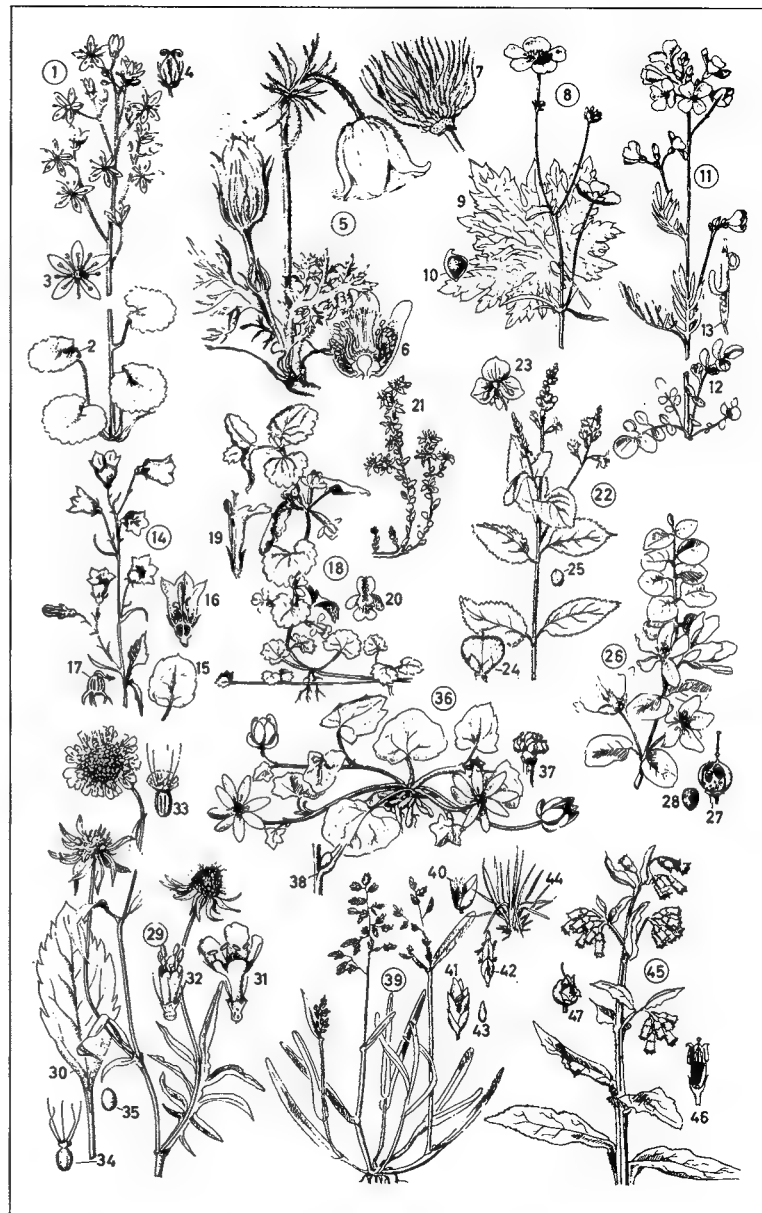

- 1 daisy (*Am.* English daisy)
- 2 flower
- 3 fruit
- 4 oxeye daisy (white oxeye daisy, marguerite)
- 5 flower
- 6 fruit
- 7 masterwort
- 8 cowslip
- 9 great mullein (Aaron's rod, shepherd's club)
- 10 bistort (snakeweed)
- 11 flower
- 12 knapweed
- 13 common mallow
- 14 fruit
- 15 yarrow
- 16 self-heal
- 17 bird's foot trefoil (bird's foot clover)
- 18 horsetail (*equisetum*) [a shoot]
- 19 flower (strobile)
- 20 campion (catchfly)
- 21 ragged robin (cuckoo flower)
- 22 birthwort
- 23 flower
- 24 crane's bill
- 25 wild chicory (witloof, succory, wild endive)
- 26 common toadflax (butter-and-eggs)
- 27 lady's slipper (*Venus's slipper*, *Am.* moccasin flower)
- 28 orchis (wild orchid, an orchid)

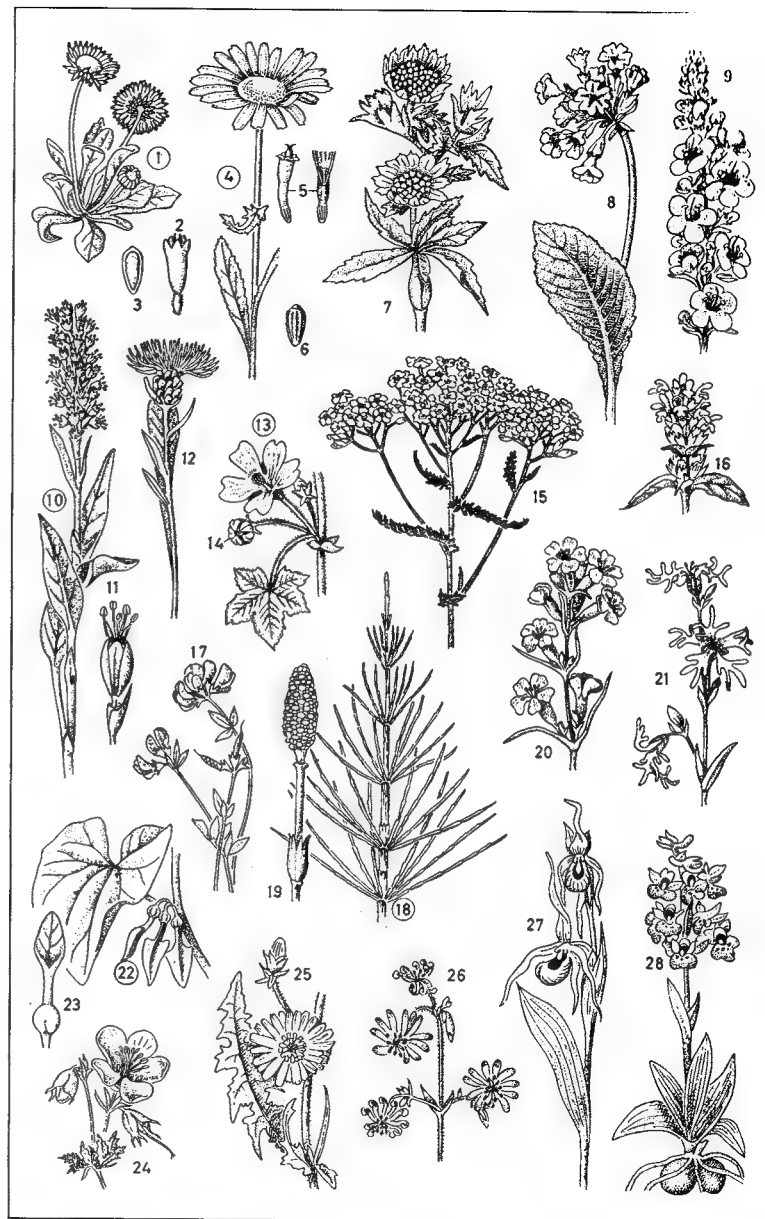

- 1 wood anemone (anemone, wind-flower)
- 2 lily of the valley
- 3 cat's foot (milkwort); *sim.*: sand-flower (everlasting)
- 4 turk's cap (turk's cap lily)
- 5 goatsbeard (goat's beard)
- 6 ramson
- 7 lungwort
- 8 corydalis
- 9 orpine (livelong)
- 10 daphne
- 11 touch-me-not
- 12 staghorn (stag horn moss, stag's horn, stag's horn moss, coral evergreen)
- 13 butterwort, an insectivorous plant
- 14 sundew; *sim.*: Venus's flytrap
- 15 bearberry
- 16 polypody (polypod), ♀ fern; *sim.*: male fern, brake (bracken, eagle fern), royal fern (royal osmund, king's fern, ditch fern)
- 17 haircap moss (hair moss, golden maidenhair), a moss
- 18 cotton grass (cotton rush)
- 19 heather (heath, ling); *sim.*: bell heather (cross-leaved heather)
- 20 rock rose (sun rose)
- 21 marsh tea
- 22 sweet flag (sweet calamus, sweet sedge)
- 23 bilberry (whortleberry, huckleberry, blueberry); *sim.*: cowberry (red whortleberry), bog bilberry (bog whortleberry), crowberry (crakeberry)



**378 Alpine Plants, Aquatic Plants (Water Plants),
and Marsh Plants**

- 1-13 alpine plants
- 1 alpine rose (alpine rhododendron)
- 2 flowering shoot
- 3 alpine soldanella (soldanella)
- 4 corolla opened out
- 5 seed vessel with the style
- 6 alpine wormwood
- 7 inflorescence
- 8 auricula
- 9 edelweiss
- 10 flower shapes
- 11 fruit with pappus tuft
- 12 part of flower head (of capitulum)
- 13 stemless alpine gentian
- 14-57 aquatic plants (water plants) and marsh plants
- 14 white water lily
- 15 leaf
- 16 flower
- 17 Queen Victoria water lily (Victoria regia water lily, royal water lily, Amazon water lily)
- 18 leaf
- 19 underside of the leaf
- 20 flower
- 21 reed mace bulrush (cattail, cat's tail, cattail flag, club rush)
- 22 male part of the spadix
- 23 male flower
- 24 female part
- 25 female flower
- 26 forget-me-not
- 27 flowering shoot
- 28 flower [section]
- 29 frog's bit
- 30 watercress
- 31 stalk with flowers and immature (unripe) fruits
- 32 flower
- 33 siliqua (pod) with seeds
- 34 two seeds
- 35 duckweed (duck's meat)
- 36 plant in flower
- 37 flower
- 38 fruit
- 39 flowering rush
- 40 flower umbel

- 41 leaves
- 42 fruit
- 43 green alga
- 44 water plantain
- 45 leaf
- 46 panicle
- 47 flower
- 48 honey wrack, a brown alga
- 49 thallus (plant body, frond)
- 50 holdfast
- 51 arrow head
- 52 leaf shapes
- 53 inflorescence with male flowers [above] and female flowers [below]
- 54 sea grass
- 55 inflorescence
- 56 Canadian waterweed (Canadian pondweed)
- 57 flower

**Alpine Plants, Aquatic Plants (Water Plants), 378
and Marsh Plants**



- 1 aconite (monkshood, wolfsbane, helmet flower)
- 2 foxglove (Digitalis)
- 3 meadow saffron (naked lady, naked boys)
- 4 hemlock (Conium)
- 5 black nightshade (common nightshade, petty morel)
- 6 henbane
- 7 deadly nightshade (belladonna, banewort, dwale), a solanaceous herb
- 8 thorn apple (stramonium, stramony, *Am.* jimson weed, jimson weed, Jamestown weed, stinkweed)
- 9 cuckoo pint (lords-and-ladies, wild arum, wake-robin)
- 10-13 poisonous fungi (poisonous mushrooms, toadstools)
- 10 fly agaric (fly amanita, fly fungus), an agaric
- 11 amanita
- 12 Satan's mushroom
- 13 woolly milk cap

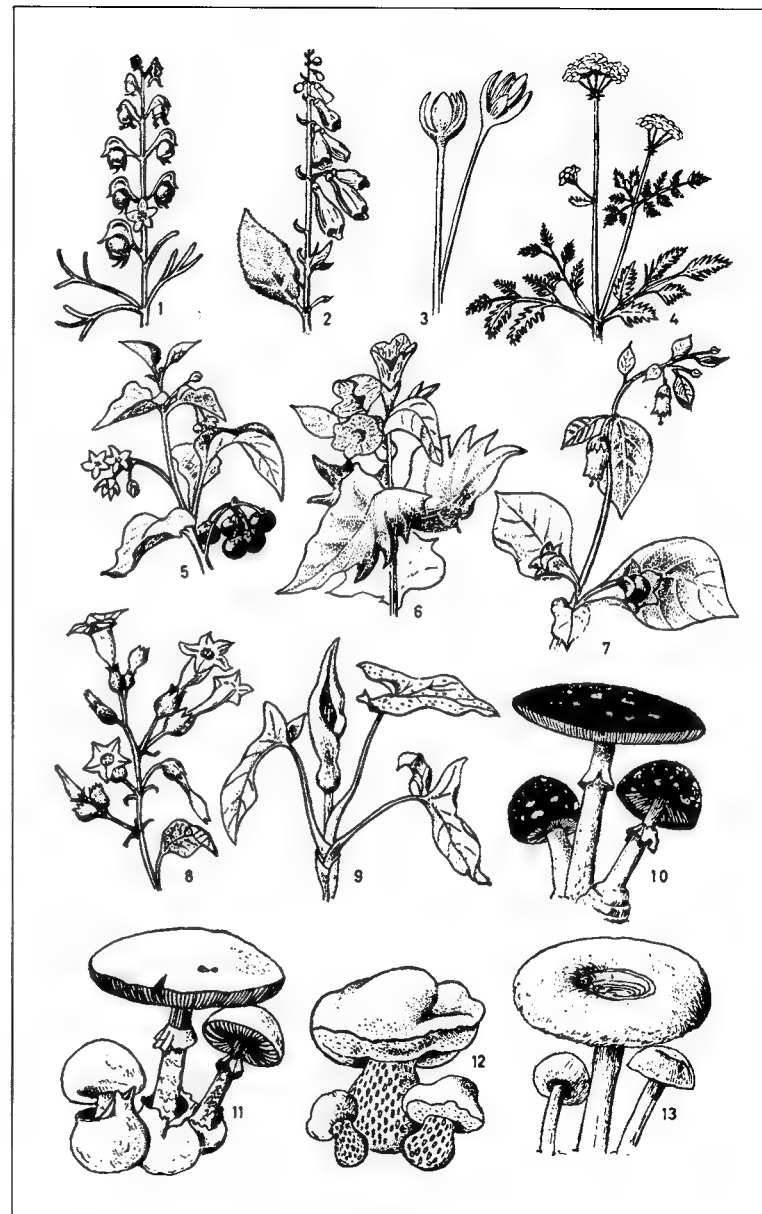

- 1 camomile (chamomile, wild camomile)
- 2 arnica
- 3 peppermint
- 4 wormwood (absinth)
- 5 valerian (allheal)
- 6 fennel
- 7 lavender
- 8 coltsfoot
- 9 tansy
- 10 centaury
- 11 ribwort (ribwort plantain, ribgrass)
- 12 marshmallow
- 13 alder buckthorn (alder dogwood)
- 14 castor-oil plant (Palma Christi)
- 15 opium poppy
- 16 senna (cassia); *the dried leaflets:*
senna leaves
- 17 cinchona (chinchona)
- 18 camphor tree (camphor laurel)
- 19 betel palm (areca, areca palm)
- 20 betel nut (areca nut)

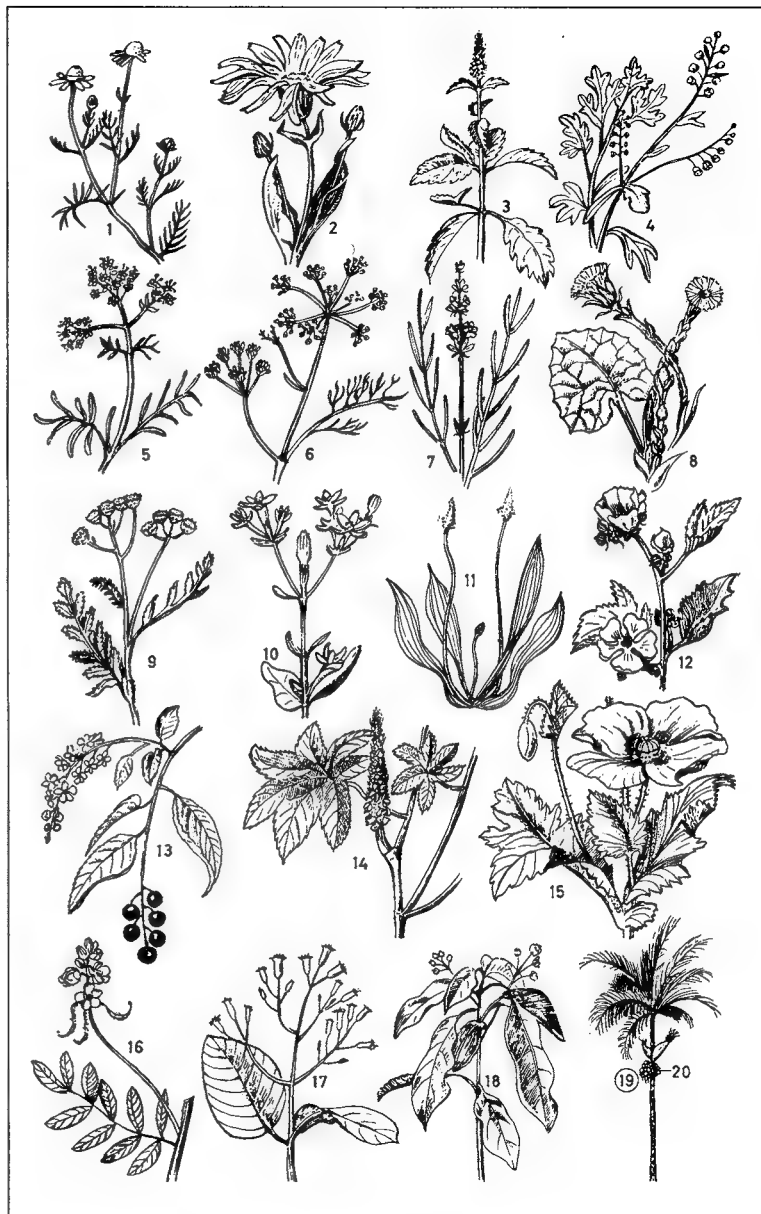

- 1 meadow mushroom (field mushroom)
- 2 mycelial threads (hyphae, mycelium) with fruiting bodies
- 3 mushroom [longitudinal section]
- 4 cap (pileus) with gills
- 5 veil (velum)
- 6 gill [section]
- 7 basidia [on the gill with basidiospores]
- 8 germinating basidiospores (spores)
- 9 truffle
- 10 truffle [external view]
- 11 truffle [section]
- 12 interior showing asci [section]
- 13 two asci with the ascospores (spores)
- 14 chanterelle (chantarelle)
- 15 Chestnut Boletus
- 16 cep (cepe, squirrel's bread, *Boletus edulis*)
- 17 layer of tubes (hymenium)
- 18 stem (stipe)
- 19 puffball (*Bovista nigrescens*)
- 20 devil's tobacco pouch (common puffball)
- 21 Brown Ring Boletus (*Boletus luteus*)
- 22 Birch Boletus (*Boletus scaber*)
- 23 *Russula vesca*
- 24 scaled prickle fungus
- 25 slender funnel fungus
- 26 morel (*Morchella esculenta*)
- 27 morel (*Morchella conica*)
- 28 honey fungus
- 29 saffron milk cap
- 30 parasol mushroom
- 31 hedgehog fungus (yellow prickle fungus)
- 32 yellow coral fungus (goatsbeard, goat's beard, coral *Clavaria*)
- 33 little cluster fungus

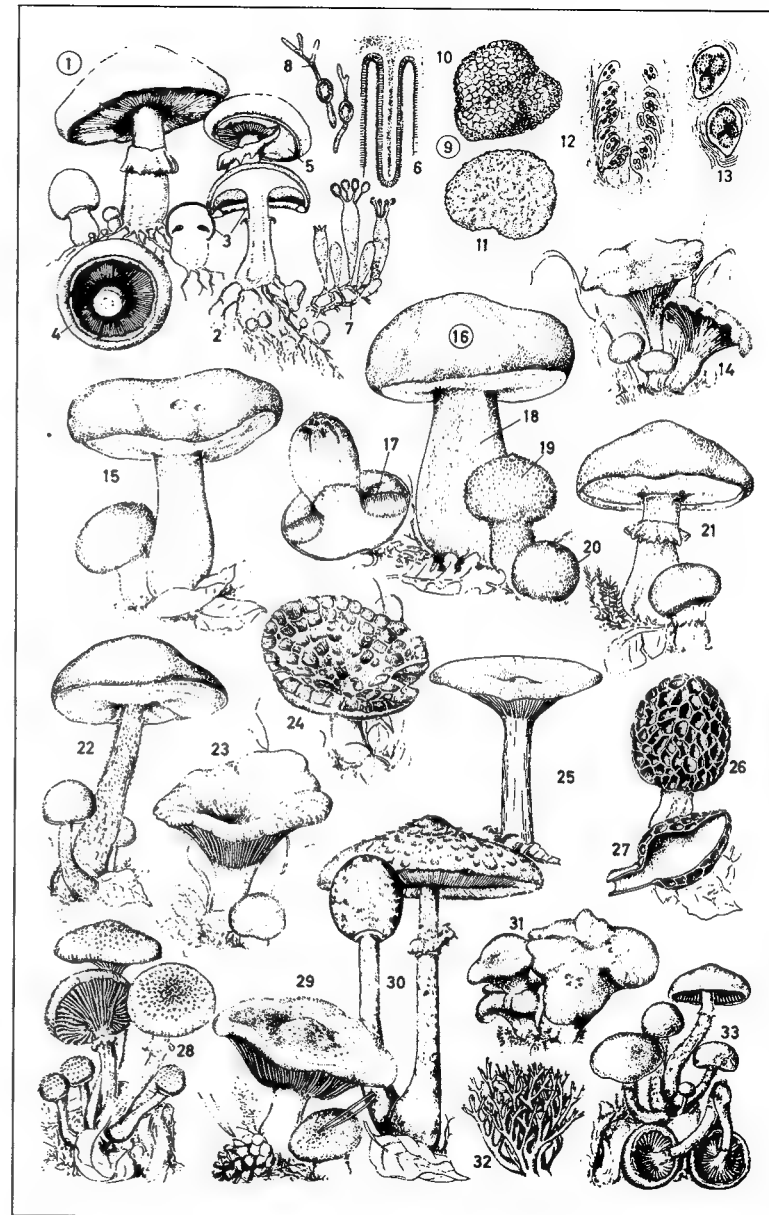

382 Tropical Plants used as Stimulants, Spices, and Flavourings (Am. Flavorings)

- | | |
|--|---|
| 1 coffee tree (coffee plant) | 38 inflorescence |
| 2 fruiting branch | 39 fruit [longitudinal section] with seed (peppercorn); <i>when ground</i> : pepper |
| 3 flowering branch | 40 Virginia tobacco plant |
| 4 flower | 41 flowering shoot |
| 5 fruit with two beans [longitudinal section] | 42 flower |
| 6 coffee bean; <i>when processed</i> : coffee | 43 tobacco leaf; <i>when cured</i> : tobacco |
| 7 tea plant (tea tree) | 44 mature (ripe) fruit capsule |
| 8 flowering branch | 45 seed |
| 9 tea leaf; <i>when processed</i> : tea | 46 vanilla plant |
| 10 fruit | 47 flowering shoot |
| 11 maté shrub (maté, yerba maté, Paraguay tea) | 48 vanilla pod; <i>when cured</i> : stick of vanilla |
| 12 flowering branch with androgynous (hermaphroditic, hermaphrodite) flowers | 49 pistachio tree |
| 13 male flower | 50 flowering branch with female flowers |
| 14 androgynous (hermaphroditic, hermaphrodite) flower | 51 drupe (pistachio, pistachio nut) |
| 15 fruit | 52 sugar cane |
| 16 cacao tree (cacao) | 53 plant in bloom |
| 17 branch with flowers and fruits | 54 panicle |
| 18 flower [longitudinal section] | 55 flower |
| 19 cacao beans (cocoa beans); <i>when processed</i> : cocoa, cocoa powder | |
| 20 seed [longitudinal section] | |
| 21 embryo | |
| 22 cinnamon tree (cinnamon) | |
| 23 flowering branch | |
| 24 fruit | |
| 25 cinnamon bark; <i>when crushed</i> : cinnamon | |
| 26 clove tree | |
| 27 flowering branch | |
| 28 flower bud; <i>when dried</i> : clove | |
| 29 flower | |
| 30 nutmeg tree | |
| 31 flowering branch | |
| 32 female flower [longitudinal section] | |
| 33 mature (ripe) fruit | |
| 34 nutmeg with mace, a seed with lacinate aril | |
| 35 seed [cross section]; <i>when dried</i> : nutmeg | |
| 36 pepper plant | |
| 37 fruiting branch | |



- 1 rape (cole, coleseed)
- 2 basal leaf
- 3 flower [longitudinal section]
- 4 mature (ripe) siliqua (pod)
- 5 oleiferous seed
- 6 flax
- 7 peduncle (pedicel, flower stalk)
- 8 seed vessel (boll)
- 9 hemp
- 10 fruiting female (pistillate) plant
- 11 female inflorescence
- 12 flower
- 13 male inflorescence
- 14 fruit
- 15 seed
- 16 cotton
- 17 flower
- 18 fruit
- 19 lint [cotton wool]
- 20 silk-cotton tree (kapok tree, capoc tree, ceiba tree)
- 21 fruit
- 22 flowering branch
- 23 seed
- 24 seed [longitudinal section]
- 25 jute
- 26 flowering branch
- 27 flower
- 28 fruit
- 29 olive tree (olive)
- 30 flowering branch
- 31 flower
- 32 fruit
- 33 rubber tree (rubber plant)
- 34 fruiting branch
- 35 fig
- 36 flower
- 37 gutta-percha tree
- 38 flowering branch
- 39 flower
- 40 fruit
- 41 peanut (ground nut, monkey nut)
- 42 flowering shoot
- 43 root with fruits
- 44 nut (kernel) [longitudinal section]
- 45 sesame plant (simsim, benniseed)
- 46 flowers and fruiting branch

- 47 flower [longitudinal section]
- 48 coconut palm (coconut tree, coco palm, cocoa palm)
- 49 inflorescence
- 50 female flower
- 51 male flower [longitudinal section]
- 52 fruit [longitudinal section]
- 53 coconut (cokernut)
- 54 oil palm
- 55 male spadix
- 56 infructescence with fruit
- 57 seed with micropyles (foramina) (foraminate seed)
- 58 sago palm
- 59 fruit
- 60 bamboo stem (bamboo culm)
- 61 branch with leaves
- 62 spike
- 63 part of bamboo stem with joints
- 64 papyrus plant (paper reed, paper rush)
- 65 umbel
- 66 spike

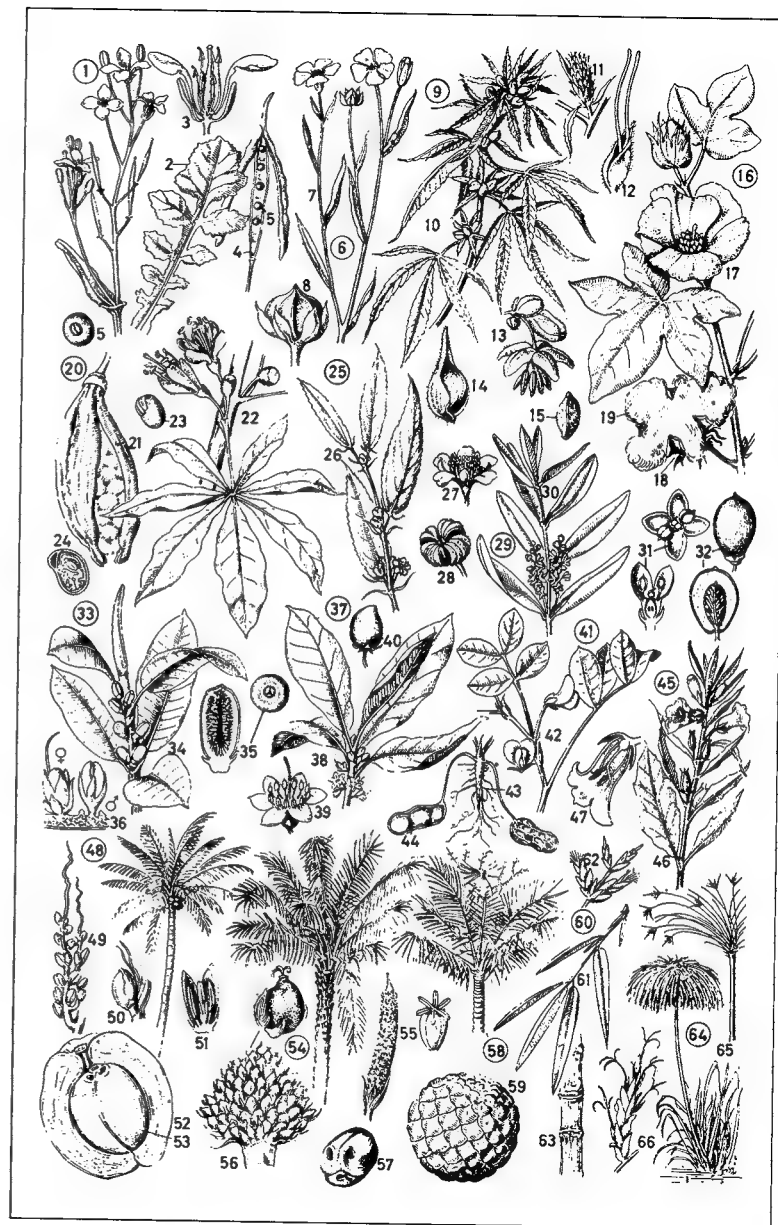

384 Southern Fruits (Tropical, Subtropical, and Mediterranean Fruits)

- 1 date palm (date)
- 2 fruiting palm
- 3 palm frond
- 4 male spadix
- 5 male flower
- 6 female spadix
- 7 female flower
- 8 stand of fruit
- 9 date
- 10 date kernel
- 11 fig
- 12 branch with pseudocarps
- 13 fig with flowers [longitudinal section]
- 14 female flower
- 15 male flower
- 16 pomegranate
- 17 flowering branch
- 18 flower [longitudinal section, corolla removed]
- 19 fruit
- 20 seed [longitudinal section]
- 21 seed [cross section]
- 22 embryo
- 23 lemon; *sim.*: tangerine (mandarin), orange, grapefruit
- 24 flowering branch
- 25 orange flower [longitudinal section]
- 26 fruit
- 27 orange [cross section]
- 28 banana plant (banana tree)
- 29 crown
- 30 herbaceous stalk with overlapping leaf sheaths
- 31 inflorescence with young fruits
- 32 infructescence (bunch of fruit)
- 33 banana
- 34 banana flower
- 35 banana leaf [diagram]
- 36 almond
- 37 flowering branch
- 38 fruiting branch
- 39 fruit
- 40 drupe containing seed [almond]
- 41 carob
- 42 branch with female flowers

- 43 female flower
- 44 male flower
- 45 fruit
- 46 siliqua (pod) [cross section]
- 47 seed
- 48 sweet chestnut (Spanish chestnut)
- 49 flowering branch
- 50 female inflorescence
- 51 male flower
- 52 cupule containing seeds
- 53 Brazil nut
- 54 flowering branch
- 55 leaf
- 56 flower [from above]
- 57 flower [longitudinal section]
- 58 opened capsule containing seeds
- 59 Brazil nut [cross section]
- 60 nut [longitudinal section]
- 61 pineapple plant (pineapple)
- 62 pseudocarp with crown of leaves
- 63 syncarp
- 64 pineapple flower
- 65 flower [longitudinal section]

Southern Fruits (Tropical, Subtropical, and Mediterranean Fruits) 384



Index

1 Atom I

1-8 atom models

- 1 model of the hydrogen (H) atom
- 2 atomic nucleus, a proton
- 3 electron
- 4 electron spin
- 5 model of the helium (He) atom
- 6 electron shell
- 7 Pauli exclusion principle (exclusion principle, Pauli principle)
- 8 complete electron shell of the Na atom (sodium atom)
- 9-14 molecular structures (lattice structures)
- 9 crystal of sodium chloride (of common salt)
- 10 chlorine ion
- 11 sodium ion
- 12 crystal of cristobalite
- 13 oxygen atom
- 14 silicon atom
- 15 energy level diagram (term diagram, possible quantum jumps) of the hydrogen atom
- 16 atomic nucleus (proton)
- 17 electron
- 18 ground state level
- 19 excited state
- 20-25 quantum jumps (quantum transitions)
- 20 Lyman series
- 21 Balmer series
- 22 Paschen series
- 23 Brackett series
- 24 Pfund series
- 25 free electron
- 26 Bohr-Sommerfeld model of the H atom
- 27 electron orbits of the electron
- 28 spontaneous decay of radioactive material
- 29 atomic nucleus
- 30-31 alpha (α) particle (alpha ray, helium nucleus)
- 30 neutron
- 31 proton
- 32 beta (β) particle (beta ray, electron)
- 33 gamma (γ) ray, a hard X-ray
- 34 nuclear fission

- الدَّوْرَة (1)
نَمَاج ذَرِيَّة
نَمُودَج ذَرَّة الهيدروجين
نَوَاة ذَرِيَّة، بروتون
إلِكْتْرُون
ذُرُور الإلِكْتْرُون
نَمُودَج ذَرَّة الهليوم
غلاف الإلِكْتْرُوني
قاعدة "بولي" للاستبعاد (قاعدة الإشتياد، قاعدة "بولي")
غلاف الإلِكْتْرُوني كَامِل لذَرَّة الصوديوم
العِيَنَات الجَزِيئِيَّة (بِنِيَات شَبَكِيَّة)
بُورَة كلوريد الصوديوم (الْمَلْح المَعْرُوف)
أْيُون الكلور
أْيُون الصوديوم
بُورَة الكريستوباليت
ذَرَّة الأكسجين
ذَرَّة السليكون
مُخَطَّط مستويات الطاقة لذَرَّة الهيدروجين (الْفَقْر الكَمِّي المُمْكِن)
نَوَاة ذَرِيَّة (بروتون)
إلِكْتْرُون
سَمْتَوِي حَالَة الخمود
حَالَة الإشتيارة
الْفَقْر الكَمِّي
مُتَسَلِّسَة "ليمان"
مُتَسَلِّسَة "بالمر"
مُتَسَلِّسَة "باشن"
مُتَسَلِّسَة "براكيت"
مُتَسَلِّسَة "فونْت"
إلِكْتْرُون حر/ طليق
نَمُودَج ذَرَّة الهيدروجين ليونر وسمزفيلد
العَدَارَات الإلِكْتْرُونِيَّة للإلِكْتْرُون
الانْتِخَال الفُورِي للمادة المُشَعَّة
نَوَاة ذَرِيَّة
جِسْمِيَم ألفا (شعاع ألفا، نَوَاة الهليوم)
نيترون
بروتون
جِسْمِيَم بيتا (شعاع بيتا، إلِكْتْرُون)
إشعاع جاما
الانْتِطَار النُوي

- 35 heavy atomic nucleus
- 36 neutron bombardment
- 37-38 fission fragments
- 39 released neutron
- 40 gamma (γ) ray
- 41 chain reaction
- 42 incident neutron
- 43 nucleus prior to fission
- 44 fission fragment
- 45 released neutron
- 46 repeated fission
- 47 fission fragment
- 48 controlled chain reaction in a nuclear reactor
- 49 atomic nucleus of a fissionable element
- 50 neutron bombardment
- 51 fission fragment (new atomic nucleus)
- 52 released neutron
- 53 absorbed neutrons
- 54 moderator, μ retarding layer of graphite
- 55 extraction of heat (production of energy)
- 56 X-ray
- 57 concrete and lead shield
- 58 bubble chamber for showing the tracks of high-energy ionising particles
- 59 light source
- 60 camera
- 61 expansion line
- 62 path of light rays
- 63 magnet
- 64 beam entry point
- 65 reflector
- 66 chamber

2 Atom II

- 1-23 radiation detectors (radiation meters)
- 1 radiation monitor
- 2 ionization chamber (ion chamber)
- 3 central electrode
- 4 measurement range selector
- 5 instrument housing
- 6 meter
- 7 zero adjustment
- 8-23 dosimeter (dose-meter)
- 8 film dosimeter
- 9 filter

- نَوَاة ذَرِيَّة ثَقِيلَة
قَبْلَة نيترونية
شَطَابَا انْتِطَارِيَّة
نيترون مُتَطَلَق
إشعاع جاما
تفاعل مُتَسَلِّس
النيترون السَّاقِط
النَوَاة قَبْل الانْتِطَار
شَطْبِيَّة انْتِطَارِيَّة
نيترون مُتَطَلَق
انْتِطَار مُتَكَرِّر
شَطْبِيَّة انْتِطَارِيَّة
تفاعل مُتَسَلِّس مُحَكَّم فِي مفاعل نُوي
النَوَاة الذَرِيَّة لِعَنْصُر انْتِطَارِي
قَبْلَة نيترونية
شَطْبِيَّة انْتِطَارِيَّة (نَوَاة ذَرِيَّة جَدِيدَة)
نيترون مُتَطَلَق
نيترونات مُتَمَصَّة
وسيط مُهَدِّئ
النيترونات (طَبَقَة مُهَدِّئَة من الجرافيت)
إسْتِخْلَاص الحرارة (إِنْتِاج الطاقة)
إشعاع سيني
لوح من الخرسانة والرصاص
حِجْرَة الفَقَاعَات لِإِظْهَار مَسَالِك الجِسْمِيَمَات المُوَبَّئَة عَالِيَة الطاقة
مُضَدَّر ضَوْء
آلَة تَصْوِير، كاميرا
حِطَّ العَدَد
مَسَار أشعة الضوء
مُغْنَطِيس
نَقْطَة دَخُول الحَزْمَة الضَوْبِيَّة
عَاكِس
غُرْفَة، حِجْرَة
- الدَّوْرَة (2)
مُكْتَشَف الإشعاع (عَدَادَات قِيَاس الإشعاع)
مِرْقَاب الإشعاع
غُرْفَة التَّايِن
نَمِيَت الجِهَاز
عَدَاد، مِقْيَاس
ضَبْط قِرَاءَة الصُّفْر
مِقْيَاس الجُرْعَات الإشعَاعِيَّة
مِقْيَاس جُرْعَات إشعَاعِيَّة غَضَائِي
مُرَشِّح، فِلْتَر

47 Pictor (the Painter)	كُرسي المصنور
48 Reticulum (the Net)	الشبكة
4 Astronomy II	(2) الفلك
1-9 the moon	القمر
1 moon's path (moon's orbit round the earth)	مدار القمر حول الأرض
2-7 lunar phases (moon's phases) (lunation)	منازل القمر
2 new moon	قمر أول الشهر
3 crescent (crescent moon, waxing moon)	هلال
4 half-moon (first quarter)	التربيع الأول
5 full moon	بدر
6 half-moon (last quarter, third quarter)	التربيع الأخير
7 crescent (crescent moon, waning moon)	محاق (هلال)
8 the earth (terrestrial globe)	الأرض (الكرة الأرضية)
9 direction of the sun's rays	اتجاه أشعة الشمس
10-21 apparent path of the sun at the beginning of the seasons	المسار الظاهري للشمس في بداية الفصول
10 celestial axis	المحور الفلكي/ السماوي
11 zenith	سُمّت الرأس
12 horizontal plane	سُستوى أفقي
13 nadir	تغير السمت
14 east point	نقطة الشرق
15 west point	نقطة الغرب
16 north point	نقطة الشمال
17 south point	نقطة الجنوب
18 apparent path of the sun on 21 December	المسار الظاهري للشمس يوم 21 ديسمبر
19 apparent path of the sun on 21 March and 23 September	المسار الظاهري للشمس يوم 21 مارس ويوم 23 سبتمبر
20 apparent path of the sun on 21 June	المسار الظاهري للشمس يوم 21 يونيو
21 border of the twilight area	حد منطقة الشفق/ السحر
22-28 rotary motions of the earth's axis	الحركات الدورانية لمحور الأرض
22 axis of the ecliptic	محور مدار الشمس
23 celestial sphere	الظاهري بين البروج
24 path of the celestial pole [precession and nutation]	الفئة السماوية
25 instantaneous axis of rotation	مسار القطب السماوي
26 celestial pole	المحور اللحظي للدوران
27 mean axis of rotation	القطب السماوي
28 polhode	المحور المتوسط للدوران
29-35 solar and lunar eclipse (not to scale)	مسار دوران محوري كسوف الشمس وكسوف القمر
29 the sun	الشمس

18 Virgo (the Virgin) with Spica	العذراء مع السُّبلة
19 Libra (the Balance, the Scales)	الميزان
20 Serpens (the Serpent)	السُّعْبان
21 Hercules	هرقل، الهياضي
22 Lyra (the Lyre) with Vega	القيثارة مع النسر الواقع
23 Cygnus (the Swan, the Northern Cross) with Deneb	الدَّجاجة مع ذنب الدَّجاجة
24 Andromeda	اندروميدا المرأة المسلسلة
25 Taurus (the Bull) with Aldebaran	الثور مع الدبران
26 The Pleiades (Pleiads, the Seven Sisters) an open cluster of stars	الثريا
27 Auriga (the Wagoner, the Charioteer) with Capella	العنان مع العيوق
28 Gemini (the Twins) with Castor and Pollux	الجوزاء مع خير التوأمين وورأس التوأم المؤخر
29 Ursa Major (the Great Bear, the Greater Bear, the Plough, Charles's Wain, Am, the Big Dipper) with the double star (binary star) Mizar and Alcor	الدب الأكبر مع الإزار والذكور
30 Boötes (the Herdsman) with Arcturus	راعِي الشَّاء/ العواء مع
31 Corona Borealis (the Northern Crown)	السمك الرامح
32 Draco (the Dragon)	الإكليل الشمالي
33 Cassiopeia	التنين
34 Ursa Minor (the Little Bear, Lesser Bear, Am, Little Dipper) with the Pole Star (Polaris, the North Star)	ذات الكرسي
35 the Milky Way (the Galaxy)	الدب الأصغر مع النجم القطبي
36-48 the southern sky	السَّمَاء الجنوبية
36 Capricorn (the Goat, the Sea Goat)	الجدي
37 Sagittarius (the Archer)	القوس
38 Scorpio (the Scorpion)	العقرب
39 Centaurus (the Centaur)	قنطورس، الظلمان
40 Triangulum Australe (the Southern Triangle)	المثلث الجنوبي
41 Pavo (the Peacock)	الطاووس
42 Grus (the Crane)	الكركي
43 Octans (the Octant)	الثمن
44 Crux (the Southern Cross, the Cross)	الصليب الجنوبي
45 Argo (the Celestial Ship)	برج السفينة
46 Carina (the Keel)	الجُجُو

48 dust shield	وقاء التراب
49 synchrotron	السينكروترون
50 danger zone	منطقة الخطر
51 magnet	مغناطيس
52 pumps for emptying the vacuum chamber	مضخات تفريغ الحجرة الخوائية
3 Astronomy I	(1) الفلك
1-35 star map of the northern sky (northern hemisphere)	خريطة النجوم الخاصة بالسماء الشمالية (نصف الكرة الشمالي)
1-8 divisions of the sky	أقسام السماء
1 celestial pole with the Pole Star (Polaris, the North Star)	القطب السماوي مع النجم القطبي (النجم الشمالي)
2 ecliptic (apparent annual path of the sun)	فلك البروج (مدار الشمس السنوي الظاهري بين البروج)
3 celestial equator (equinoctial line)	خط الاستواء السماوي
4 tropic of Cancer	مدار السرطان
5 circle enclosing circumpolar stars	الدائرة المحيطة بالنجوم الكائنة حول القطب
6-7 equinoctial points (equinoxes)	نقطتا الاعتدال الربيعي والخريفي
6 vernal equinoctial point (first point of Aries)	نقطة الاعتدال الربيعي
7 autumnal equinoctial point	نقطة الاعتدال الخريفي
8 summer solstice	الانقلاب الصيفي
9-48 constellations (grouping of fixed stars into figures) and names of stars	الكوكبات وأسماء النجوم
9 Aquila (the Eagle) with Altair the principal star (the brightest star)	العقاب مع النسر الطائر (أكثر النجوم سطوعاً)
10 Pegasus (the Winged Horse)	الفرس الأعظم (الفرس الممتح)
11 Cetus (the Whale) with Mira, a variable star	قيطس (الحوث) مع ميرا
12 Eridanus (the Celestial River)	النهر
13 Orion (the Hunter) with Rigel, Betelgeuse and Bellatrix	الجوزاء مع رجل الجوزاء اليسرى
14 Canis Major (the Great Dog, the Greater Dog) with Sirius (the Dog Star), a star of the first magnitude	الكلب الأكبر مع الشعري اليمانية
15 Canis Minor (the Little Dog, the Lesser Dog) with Procyon	الكلب الأصغر مع الشعري الشمالية
16 Hydra (the Water Snake, the Sea Serpent)	السُّحْباج (ثعبان الماء)
17 Leo (the Lion) with Regulus	الأسد مع قلب الأسد

10 film	غشاء رقيق
11 film-ring dosimeter	مقياس جرعات إشعاعية
12 filter	غشائي حثفي
13 film	مُرَشِّح، فلتر
14 cover with filter	غشاء رقيق
15 pocket meter (pen meter, pocket chamber)	غطاء مُرَوِّد بمُرَشِّح مقياس جيب
16 window	حجرة
17 ionization chamber (ion chamber)	غرفة التأين
18 clip (pen clip)	مشبك
19 Geiger counter (Geiger-Müller counter)	عداد "جايغر"
20 counter tube casing	غلاف أنبوب العداد
21 counter tube	أنبوب العداد
22 instrument housing	مبيت الآلة
23 measurement range selector	مفتاح انتقاء مدى القياس
24 Wilson cloud chamber (Wilson chamber)	حجرة "ولسن" الغيمية
25 compression plate	لوح ضغط
26 cloud chamber photograph	صورة الحجرة الغيمية
27 cloud chamber track of an alpha particle	مسار جسيم ألفا في الحجرة الغيمية
28 telecobalt unit (coll. cobalt bomb)	وحدة تليكو بلت (قنبلة الكوبلت)
29 pillar stand	دعامة عمودية
30 support cables	كيبالات إسناد
31 radiation shield (radiation shielding)	درع الإشعاع
32 sliding shield	درع انزلاقي
33 bladed diaphragm	رقب متصل
34 light-beam positioning device	جهاز توضع الحزمة الضوئية
35 pendulum device (pendulum)	جهاز بندولي (بندول)
36 irradiation table	طاولة التشعيع
37 rail (track)	مسار
38 manipulator with sphere unit	جهاز معالجة مُرَوِّد بوحدة كروية
39 handle	مقبض
40 safety catch (locking lever)	زِر الأمان (ذراع قفل)
41 wrist joint	وصلة رُسغية
42 master arm	الذراع الرئيسي
43 clamping device (clamp)	جهاز تثبيت (قامبطة)
44 tongs	كلايتان
45 slotted board	لوح مثقب
46 radiation shield (protective shield, protective shielding), a lead shielding wall [section]	درع الإشعاع (درع واقٍ من الإشعاع، جدار مُدرع بالبرصاص) [مقطع]
47 grasping arm of a pair of manipulators (of a master/slave manipulator)	ذراع الإمساك الخاصة بزوج من أجهزة المعالجة (لجهاز معالج/تابع)

29 fuel tank	خزان وقود
30 engine	محرك
31 mechanism for unfolding the legs	آلية فرد أرجل السفينة
32 main shock absorber	مُخَفِّف الصَّدْمَة الرئيسي
33 landing pad	مسند الهبوط
34 ingress/egress platform (hatch platform)	منصة دخول/ خروج
35 ladder to platform and hatch	سلم مؤدي إلى المنصة والفتحة
36 cardan mount for engine	حامل كرندي للمحرك
37-47 ascent stage	مرحلة الصعود
37 fuel tank	خزان وقود
38 ingress/egress hatch (entry/exit hatch)	فتحة الدخول والخروج
39 LM manoeuvring (Am. manoeuvring) rockets	صواريخ المناورة الخاصة بالموديولات القمرية
40 window	شباك
41 crew compartment	حجرة الطاقم/ الملاحين
42 rendezvous radar antenna	هوائي رادار من أجل الالتقاء
43 inertial measurement unit	وحدة قياس القصور الذاتي
44 directional antenna for ground control	هوائي اتجاهي للتحكم الأرضي
45 upper hatch (docking hatch)	فتحة علوية
46 inflight antenna	هوائي طيران
47 docking target recess	تجويف الالتحام بمركبة أخرى في الفضاء
7 Atmosphere	الغلاف الجوي
1 the troposphere	التروبوسفير
2 thunderclouds	سحب رعدية
3 the highest mountain, Mount Everest [8,882 m]	أعلى جبل، جبل افيرست [8,882 م]
4 rainbow	قوس قزح
5 jet stream level	مستوى التيار المتدفق
6 zero level [inversion of vertical air movement]	مستوى صفر [انعكاس حركة الهواء الرأسية]
7 ground layer (surface boundary layer)	الطبقة الأرضية
8 the stratosphere	الاستراتوسفير
9 tropopause	منطقة الركود (تروبوبوز)
10 separating layer (layer of weaker air movement)	طبقة فاصلة (طبقة حركة تيار هوائي أضعف)
11 atomic explosion	انفجار ذري
12 hydrogen bomb explosion	انفجار قنبلة هيدروجينية
13 ozone layer	طبقة الأوزون
14 range of sound wave propagation	مدى انتشار الموجات الصوتية
15 stratosphere aircraft	طائرة استراتوسفيرية
16 manned balloon	مِنطاد مزود بأفراد
17 sounding balloon	مِنطاد/ بالون رصد جوي

حجرة الرصد وبها سبكتروجراف	33 observation room housing the spectrograph
الهبوط على سطح القمر	6 Moon Landing
سفينة الفضاء "أبوللو" موديل (حجرة انفضالية) خدمة	1 Apollo spacecraft
مفتح المحرك الرئيسي للصاروخ	2 service module (SM) خدمة
هوائي اتجاهي صواريخ المناورة	3 nozzle of the main rocket engine
خزانات الأكسجين والهيدروجين الخاصة بنظام طاقة السفينة	4 directional antenna
خزان وقود مشعات نظام طاقة سفينة الفضاء	5 manoeuvring (Am. manoeuvring) rockets
موديل القيادة	6 oxygen and hydrogen tanks for the spacecraft's energy system
فتحة دخول الكبسولة الفضائية	7 fuel tank
رائد فضاء	8 radiators of the spacecraft's energy system
موديل قمر	9 command module (Apollo space capsule)
سطح القمر	10 entry hatch of the space capsule
تُرَاب قَمَرِي	11 astronaut
قطعة صخرية	12 lunar module (LM)
حفرة نيزكية	13 moon's surface (lunar surface), ■ dust-covered surface
الأرض (الكرة الأرضية)	14 lunar dust
بدلة الفضاء	15 piece of rock
جهاز الأكسجين الخاص بالطوارئ	16 meteorite crater
جيب للتظار الشمسية [به نظارة شمسية للاستخدام على متن السفينة]	17 the earth
نظام دعم الحياة	18-27 space suit (extra-vehicular suit)
قلاية	18 emergency oxygen apparatus
خونة البدلة الفضائية	19 sunglass pocket [with sunglasses for use on board]
مزودة بمشعات شمسية	20 life support system (life support pack), ■ backpack unit
صندوق التحكم الخاص بنظام دعم الحياة	21 access flap
جيب لكثاف في حجم القلم	22 space suit helmet with sun filters
قلاية صمام التنظيف	23 control box of the life support pack
توصيلة الأنابيب والكتيل الخاصة بنظام الراديو والتبوية وتبريد الماء	24 night pocket
جيب للأقلام والأدوات، إلخ.	25 access flap for the purge valve
مرحلة الهبوط	26 tube and cable connections for the radio, ventilation, and water-cooling systems
آلية توصيل	27 pocket for pens, tools, etc.
	28-36 descent stage
	28 connector

الخوت	24 well
الفلك (3)	25 foyer
المركز الأوروبي الجنوبي الممثل على "سيرو لا سيلا"، شيلي [مقطع]	26 theatre (Am. theater)
المرآة الرئيسية وقمرها 3,6 م (144 بوصة)	27 projection booth
هيكل التركيز البؤري الرئيسي مزود بحامل المرآة الثانوية	28 foundation pile
مرآة مسطحة لمسار أشعة "كويدي"	29-33 the Kitt Peak solar observatory near Tucson, Ariz. [section]
قفص "كاسجرين"	29 heliostat
سبكتروجراف شبيكي	30 sunken observation shaft
كاميرا سبكتروجرافية	31 water-cooled wind-shield
ذراع تدوير المحور الساعي	32 concave mirror
المحور الساعي	
حامل على شكل حدوة فرس	
سطح ارتكاز هيدروستاتي	
أجهزة التركيز البؤري الرئيسية والثانوية	
قبة المرصد، قبة دوار	
فتحة المرصد	
غطاء قبة يتحرك رأسيًا	
حاجب الريح	
عاكسة نجمية ثابتة التوجيه (سيدروستات)	
قبة "شوتجارت" الفلكية، مفلاك "شوتجارت" [مقطع]	
منطقة الإدارة والورشة والمخزن	
سقانة حديدية	
هرم زجاجي	
سلم مقوس دوار	
قبة الإسقاط	
حاجز الضوء	
بروجكتور المفلاك	
بئر	
دهليز	
مسرح	
حجيرة الإسقاط	
خازوق الأساس	
مرصد "كيت بيك" الشمسي بالقرب من "تاكسون"، "أريز" [قطاع]	
هليوستات	
عمود رصد غاطس	
حاجب ريع مبرد بالماء	
مرآة مقعرة	

الذرة - الكون - الأرض / Atom, Universe, Earth	30 observation room housing the spectrograph
الذرة - الكون - الأرض / Atom, Universe, Earth	31 water-cooled wind-shield
الذرة - الكون - الأرض / Atom, Universe, Earth	32 concave mirror

الذرة - الكون - الأرض / Atom, Universe, Earth	33 observation room housing the spectrograph
الذرة - الكون - الأرض / Atom, Universe, Earth	34 ingress/egress platform (hatch platform)
الذرة - الكون - الأرض / Atom, Universe, Earth	35 ladder to platform and hatch
الذرة - الكون - الأرض / Atom, Universe, Earth	36 cardan mount for engine
الذرة - الكون - الأرض / Atom, Universe, Earth	37-47 ascent stage
الذرة - الكون - الأرض / Atom, Universe, Earth	37 fuel tank
الذرة - الكون - الأرض / Atom, Universe, Earth	38 ingress/egress hatch (entry/exit hatch)
الذرة - الكون - الأرض / Atom, Universe, Earth	39 LM manoeuvring (Am. manoeuvring) rockets
الذرة - الكون - الأرض / Atom, Universe, Earth	40 window
الذرة - الكون - الأرض / Atom, Universe, Earth	41 crew compartment
الذرة - الكون - الأرض / Atom, Universe, Earth	42 rendezvous radar antenna
الذرة - الكون - الأرض / Atom, Universe, Earth	43 inertial measurement unit
الذرة - الكون - الأرض / Atom, Universe, Earth	44 directional antenna for ground control
الذرة - الكون - الأرض / Atom, Universe, Earth	45 upper hatch (docking hatch)
الذرة - الكون - الأرض / Atom, Universe, Earth	46 inflight antenna
الذرة - الكون - الأرض / Atom, Universe, Earth	47 docking target recess

الذرة - الكون - الأرض / Atom, Universe, Earth	30 observation room housing the spectrograph
الذرة - الكون - الأرض / Atom, Universe, Earth	31 water-cooled wind-shield
الذرة - الكون - الأرض / Atom, Universe, Earth	32 concave mirror

32 rain مطر
 33 drizzle رَدَان
 34 snow ثَلْج
 35 ice pellets (graupel, soft hail) برد رَخو
 36 hail برد
 37 shower وابل
 38 thunderstorm عاصفة رعدية
 39 lightning برق
40-58 climatic map الخريطة المناخية
 40 isotherm (line connecting points having equal mean temperature) خط تساوي درجة الحرارة الأرضية، خط الحَارَر
 41 0°C (zero) isotherm (line connecting points having a mean annual temperature of 0°C) خط الحَارَر الصْفَرِي (خط يربط نقاطاً لها متوسط درجة حرارة سنوي يبلغ صفرًا متوياً)
 42 isocheim (line connecting points having equal mean winter temperature) خط تساوي القَرِّ (خط يربط نقاطاً لها متوسط حرارة متساوي في الشتاء)
 43 isother (line connecting points having equal mean summer temperature) خط تساوي القَيْظ (خط يربط نقاطاً لها متوسط حرارة متساوي في الصيف)
 44 isohel (line connecting points having equal duration of sunshine) خط تساوي السُّوع الشمسي
 45 isohyet (line connecting points having equal amounts of precipitation) خط تساوي المطر (خط يربط نقاطاً لها كمية متساوية من التساقط)
46-52 atmospheric circulation (wind systems) الدورة الجوية (أنظمة الرياح)
 46-47 calm belts حزامان ساكنان
 46 equatorial trough (equatorial calms, doldrums) نطاق الرهُو الاستوائي
 47 subtropical high-pressure belts (horse latitudes) عروض الخيل (منطقتان مستقرتا الطقس بين القطبين)
 48 north-east trade winds (north-east trades, tropical easterlies) رياح تجارية شمالية شرقية
 49 south-east trade winds (south-east trades, tropical easterlies) رياح تجارية جنوبية شرقية
 50 zones of the variable westerlies مناطق الرياح الغربية المتغيرة
 51 polar wind zones مناطق الرياح القطبية
 52 summer monsoon رياح موسمية صيفية
53-58 earth's climates الأقاليم المناخية الأرضية
 53 equatorial climate: tropical zone (tropical rain zone) المناخ الاستوائي المنطقتان المدارية (منطقة الأمطار الاستوائية)
 54 the two arid zones (equatorial dry zones): desert and steppe zones المنطقتان القاحلتان منطقتا الصحراء والسَّهْب

1000 (مليار)
 3 mciobar (isobar of under 1,000 mb) مايوبار (اليسوبار يقل عن 1000 مليبار)
 4 atmospheric (barometric) pressure given in millibars الضغط الجوي مقاساً بالمليبار
 5 low-pressure area (low, cyclone, depression) منطقة ضغط منخفض
 6 high-pressure area (high, anticyclone) منطقة ضغط مرتفع
 7 observatory (meteorological watch office, weather station) or ocean station vessel (weather ship) مرصد (محطة أرصاد جوية) أو سفينة أرصاد جوية
 8 temperature درجة الحرارة
9-19 means of representing wind direction (wind-direction symbols) طرق/رموز تمثيل اتجاه الرياح
 9 wind-direction shaft (wind arrow) سهم تحديد اتجاه الرياح
 10 wind-speed barb (wind-speed feather) ريشة تحديد سرعة الرياح
 11 calm هادئة
 12 1-2 knots (1 knot = 1.852 kph) 2-1 عقدة العقدة = 1.852 كم/س
 13 3-7 knots 7-3 عقد
 14 8-12 knots 12-8 عقدة
 15 13-17 knots 17-13 عقدة
 16 18-22 knots 22-18 عقدة
 17 23-27 knots 27-23 عقدة
 18 28-32 knots 32-28 عقدة
 19 58-62 knots 62-58 عقدة
20-24 state of the sky (distribution of the cloud cover) حالة السماء (توزيع السحب)
 20 clear (cloudless) صافية (خالية من الغيوم)
 21 fair سَحْب قليلة
 22 partly cloudy غائمة جزئياً
 23 cloudy غائمة
 24 overcast (sky mostly or completely covered) ملبدة بالغيوم
25-29 fronts and air currents الجبهات والتيارات الهوائية
 25 occlusion (occluded front) جبهة مغلقة
 26 warm front جبهة دافئة
 27 cold front جبهة باردة
 28 warm airstream (warm current) تيار (هواء) دافئ
 29 cold airstream (cold current) تيار (هواء) بارد
30-39 meteorological phenomena الظواهر المناخية
 30 precipitation area منطقة تساقط (مطر أو ثلج أو ندى) ضباب
 31 fog ضباب

cloud (sheet cloud) of medium height سحب طبقي متوسط يَحْمَلُ أمطاراً/ثلوجاً في أجزائه العلوية
 9 altostratus praecipitans, a layer cloud (sheet cloud) with precipitation in its upper parts مرزن طبقي مطير، الخفيف
 10 nimbostratus, a rain cloud, a layer cloud (sheet cloud) of very large vertical extent which produces precipitation (rain or snow) مرزن جزئي يظهر أسفل الخفيف
 11 fractostratus, a ragged cloud occurring beneath nimbostratus ركامي جزئي
 12 fractocumulus, a ragged cloud like 11 but with billowing shapes السحب في الجبهات الباردة
13-17 clouds at cold fronts جبهة باردة
 13 cold front سمحاق ركامي عندما يُطْفِئ السماء يَطلِقُ عليها السماء الإِسْفَرِيَّة
 14 cirrocumulus, thin fleecy cloud in the form of globular masses; covering the sky: mackerel sky سحاب ركامي متوسط
 15 altocumulus, a cloud in the form of large globular masses سحاب صيفي قلاعي وندفة
 16 altocumulus castellanus and altocumulus floccus, species of 15 سحاب طبقي متوسط (نوع من السحاب الركامي المتوسط)
 17 cumulonimbus, a heap cloud of very large vertical extent, to be classified under 1-4 in the case of tropical storms ركامي مطير، يُصنّف تحت الأنواع من 1-4 في حالة العواصف المدارية
18-19 types of precipitation نوعا التساقط
 18 steady rain or snow covering a large area, precipitation of uniform intensity تساقط ذو كثافة منتظمة، أمطار أو ثلوج متواصلة تغطي منطقة واسعة
 19 shower, scattered precipitation وابل، همزة
9 Meteorology II and Climatology وعلم المناخ
1-39 weather chart خريطة الطقس الجوي
 (weather map, surface chart, surface synoptic chart)
 1 isobar (line of equal or constant atmospheric or barometric pressure at sea level) يسوبار خط تساوي الضغط الجوي
 2 plicobar (isobar of over بلايوبار (يسوبار يزيد عن

18 meteor نيزك، شهاب
 19 upper limit of ozone layer الحد العلوي لطبقة الأوزون
 20 zero level مستوى صفر
 21 eruption of Krakatoa انفجار بركان "كراكاتوا"
 22 luminous clouds (noctilucent clouds) سَحْب (الليلة) مضيئة
 23 the ionosphere الأيونوسفير
 24 range of research rockets مدى صواريخ البحوث
 25 shooting star شهاب، نيزك
 26 short wave (high frequency) موجة قصيرة (تردد عال)
 27 E-layer (Heaviside-Kennelly Layer) طبقة "كيلي" و"هيفيسايد"
 28 F1-layer طبقة أبلتون - 1
 29 F2-layer طبقة أبلتون - 2
 30 aurora (polar light) الشفق (ضوء قطبي)
 31 the exosphere الإكسوسفير
 32 atom layer طبقة ذرية
 33 range of satellite sounding مدى السبر بالقمر الصناعي
 34 fringe region منطقة حافية
 35 altitude scale مقياس الارتفاع
 36 temperature scale (thermometric scale) مقياس الحرارة
 37 temperature graph الرسم البياني للحرارة
8 Meteorology I الأرصاد الجوية (1)
1-19 clouds and weather السحب والطقس
1-4 clouds found in homogeneous air masses السحب الموجودة في كتل الهواء المتجانسة
 1 cumulus (woolpack cloud), a heap cloud; here: cumulus humilis (fair-weather cumulus), a flat-based heap cloud ركام، سحاب كثوي
 2 cumulus congestus, a heap cloud with more marked vertical development ركام كومي
 3 stratocumulus, a layer cloud (sheet cloud) arranged in heavy masses ركامي طبقي
 4 stratus (high fog), a thick, uniform layer cloud (sheet cloud) رهل سحاب طبقي كثيف متبسط
5-12 clouds found at warm fronts السحب في الجبهات الدافئة
 5 warm front جبهة دافئة
 6 cirrus, a high to very high ice-crystal cloud, thin and assuming a wide variety of forms قرع، طخاء سحاب رقيق سمحاق
 7 cirrostratus, an ice-crystal cloud veil سمحاق طبقي
 8 altostratus, a layer سحاب طبقي متوسط، رباب

فَتْحَةٌ بُرْكَانٍ خَامِدٍ
 المغناطيسية البْلوتونية
 باثُوليت
 لاجُوليت، تَدَاخُلُ
 سِدِّ نَارِي
 الزُّلْزَالُ (نَوْعَاهُ تَتَكَوَّنُ، بُرْكَانِي) وَعِلْمُ الزُّلْزَالِ
 مَرَكِزُ الزُّلْزَالِ الجَوْفِيُّ
 مَرَكِزُ الزُّلْزَالِ السُّطْحِي
 عَمَقُ مَرَكِزِ الزُّلْزَالِ
 مَوْجَةٌ صُنْدِيَّةٌ
 مَوْجَاتُ زَلْزَالِيَّةٍ سَطْحِيَّةٍ
 خَطٌّ شَاوِي شِدَّةُ الزُّلْزَالَةِ
 مَحْلَقَةٌ مَرَكِزُ الزُّلْزَالِ السُّطْحِي
 سِزْمُوجِرَافِ أَفْقِي
 مَضَائِلُ كَهْرُومَغْنَاطِيسِي
 مِقْيَاسُ التَّعْدِيلِ الخَاصِ
 بِفَتْرَةِ التَّدَايِبِ العُرْزِ لِلبِنْدُولِ
 وَصَلَةُ النَابِضِ الخَاصَةِ
 بِتَغْلِيقِ البِنْدُولِ
 كَلْبَةٌ
 مَلْفَاتُ الحَدِّ الخَاصَةِ
 بِتَسْجِيلِ فُولْتِيَّةِ الجِلْفَانُومِتِرِ
 أُنْثَارُ الزُّلْزَالِ
 شَلَالٌ
 انْتِزَاقٌ أَرْضِي، انْتِهْيَارٌ
 رُكَامٌ
 صُنْحَرَةٌ خَفِيفَةٌ
 حَفْرَةٌ بِالوَعِيَّةِ، نَحْلٌ
 انْفِصَامٌ، زَحْرَحَةٌ، انْتِجَالٌ
 وَفِيَّةٌ زَحْفُ التُّرْبَةِ
 شِقٌّ، فَاصِلٌ
 مَوْجَةٌ سِينَامِيَّةٌ نَاتِجَةٌ عَنِ

تَصْفِيحَةٌ شَمْسِيَّةٌ
 آلَةٌ تَصْوَيرُ تَلِفِيزِيُونِي
 هَوَانِي
 جِهَازُ اسْتِشْعَارِ شَمْسِي
 هَوَانِي اسْتِشْعَارٌ عَنِ بَعْدِ
 رَاديومتر (جِهَازُ مِقْيَاسِ
 الإِشْعَاعِ)
 الجُغْرَافِيَّةُ الطَّبِيعِيَّةُ (1)
 الهَيْكَلُ الطَّبَاقِي لِلأَرْضِ
 القَشْرَةُ الأَرْضِيَّةُ
 غِلافُ الأَرْضِ الخَامِدِ
 الغِلافُ الصُّخْرِي، الدَّنَّارُ،
 وَشَاحُ الأَرْضِ
 سِيْمَا القَشْرَةِ العَمِيقَةُ (طبقة
 مِتَوَسِطَةٌ)
 اللب، جَوْفُ الأَرْضِ (الكَرَّةُ
 البَاطِنِيَّةُ التَّيْقِيَّةُ)
 مَحْدِنُ هَيْسُوجِرَافِي
 السُّطْحُ الأَرْضِ
 قِمَّةٌ، ذُرْوَةٌ
 كَلْبَةٌ قَارِيَّةٌ
 رَصِيفٌ قَارِيٌّ
 مَحْدَرٌ قَارِيٌّ
 قَاعُ البَحْرِ (سَطْحٌ مَسْتَوٍ
 غُورِي)
 مَسْتَوَى سَطْحِ البَحْرِ
 وَهْدٌ تَحْتَ البَحْرِ
 التُّرْكَانِيَّةُ
 بُرْكَانٌ قِيَامِي
 هَضْبَةٌ لَابِيَّةٌ
 بُرْكَانٌ نَشِطٌ
 قُوَّةٌ بُرْكَانِيَّةٌ
 فَتْحَةُ البُرْكَانِ
 مِجْرَى اللَّابَةِ
 مَلْفَةٌ
 بُرْكَانٌ بَاطِنِيٌّ
 حَمَّةٌ فَوَارَةٌ
 نَفْثٌ مِنَ المَاءِ السَّاحِنِ
 شُرْفَاتٌ لَبِيدَةٌ
 مَحْرُوطٌ
 قُوَّةٌ بُرْكَانِيَّةٌ (بُرْكَانٌ
 خَامِدٌ)
 رَوَاسِبٌ طَفِيَّةٌ
 بَرِيضَةٌ

66 solar panel
 67 television camera
 68 antenna
 69 solar sensor (sun sensor)
 70 telemetry antenna
 71 radiometer
 11 Physical Geography I
 1-5 layered structure of the earth
 1 earth's crust (outer crust of the earth, lithosphere, oxysphere)
 2 hydrosphere
 3 mantle
 4 sima (intermediate layer)
 5 core (earth core, centrosphere, barysphere)
 6-12 hypsographic curve of the earth's surface
 6 peak
 7 continental mass
 8 continental shelf (continental platform, shelf)
 9 continental slope
 10 deep-sea floor (abyssal plane)
 11 sea level
 12 deep-sea trench
 13-28 volcanism (volcanicity)
 13 shield volcano
 14 lava plateau
 15 active volcano, a stratovolcano (composite volcano)
 16 volcanic crater (crater)
 17 volcanic vent
 18 lava stream
 19 tuff (fragmented volcanic material)
 20 subterranean volcano
 21 geyser
 22 jet of hot water and steam
 23 sinter terraces (siliceous sinter terraces, fiorite terraces, pearl sinter terraces)
 24 cone
 25 maar (extinct volcano)
 26 tuff deposit
 27 breccia

بُوصَلَاتُ نَصْفِ كُرْوِيَّةٍ
 مُؤَشِّرُ اتِّجَاهِ الرِّيحِ
 دَوَّارَةُ الرِّيحِ
 مِقْيَاسُ رَطُوبِيَّةِ الجَوِّ السَّافِطِ
 تَرْمُومِتِرٌ ذُو بُصْبِلَةٍ جَافَةٍ
 تَرْمُومِتِرٌ ذُو بُصْبِلَةٍ مَحْضَلَّةٍ
 وَقَاهُ/حَاجِبُ الإِشْعَاعِ
 الشَّمْسِيِّ
 أَنْبُوبٌ مَاصٌ
 مِقْيَاسٌ تَسْجِيلُ كِمِيَةِ المَطَرِ
 غِلافٌ واقٍ
 وَعَاءٌ تَجْمِيعٌ
 غِطَاءٌ واقٍ مِنَ المَطَرِ
 آليَّةُ التَّسْجِيلِ
 مَمْحَصُ الأَنْبُوبِ مَحْضِي
 مِقْيَاسُ التَّنَاسُطِ
 وَعَاءٌ تَجْمِيعٌ
 وَعَاءٌ تَخْزِينٌ
 مِخْطَارٌ مِقْيَاسٌ
 وَابِيحَةٌ لِمِقْيَاسِ كِمِيَةِ سَقُوطِ
 الجَلِيدِ
 وَقَاهُ التَّرْمُومِتِرِ
 مَرَسَمَةُ الرُّطُوبِيَّةِ الشَّمْسِيَّةِ
 (هَيْسُوجِرَافِ)
 تَرْمُوجِرَافِ
 مِقْيَاسُ رَطُوبِيَّةِ الجَوِّ
 تَرْمُومِتِرَاتٌ لِمِقْيَاسِ
 نِجَاحَاتِ الحَرَارَةِ القُصُويِّ
 وَالنَّهْيِ
 تَرْمُومِتِرٌ ذَرَجَةِ الحَرَارَةِ
 القُصُويِّ
 تَرْمُومِتِرٌ ذَرَجَةِ الحَرَارَةِ
 الدُّنْيَا
 مَجْمُوعَةٌ مَسَارٍ لَاسَلِكِي
 مِظْطَادٌ بِأَنْبُوبٍ هَيْدْرُوجِينِ
 مِثْلَةٌ، بِرَاشُوتِ
 عَاكِسٌ رَادَارِيٌّ ذُو خَطُوطِ
 مِباعِدَةٍ
 مِقْرٌ/غِلافُ الآلَةِ مَزُودٌ
 بِمَسَارٍ لَاسَلِكِي (جِهَازٌ
 إِرسَالِ مَوْجَاتٍ قَاصِرَةٍ)
 وَهَوَانِي
 مِقْيَاسٌ إِتْقَانِيَّةٌ الجَوِّ
 آلَةٌ تَسْجِيلٌ
 جِهَازٌ إِرسَالٌ
 جِهَازٌ اسْتِقبَالٌ
 قَمَرٌ صِنَاعِيٌّ لِلرَّصْدِ الجَوِّيِّ
 آلَةٌ تَسْجِيلٌ
 جِهَازٌ إِرسَالٌ
 جِهَازٌ اسْتِقبَالٌ
 قَمَرٌ صِنَاعِيٌّ لِلرَّصْدِ الجَوِّيِّ
 قَلَابَاتٌ تُنظِّمُ ذَرَجَةَ
 الحَرَارَةِ

55 the two temperate rain zones
 56 boreal climate (snow forest climate)
 57-58 polar climates
 57 tundra climate
 58 perpetual frost climate
 10 Meteorological Instruments
 1 mercury barometer, a siphon barometer, a liquid-column barometer
 2 mercury column
 3 millibar scale, 11 millimetre (Am. millimeter) scale
 4 barograph, 11 self-registering aneroid barometer
 5 drum (recording drum)
 6 bank of aneroid capsules (aneroid boxes)
 7 recording arm
 8 hygrograph
 9 hygrometer element (hair element)
 10 reading adjustment
 11 amplitude adjustment
 12 recording arm
 13 recording pen
 14 change gears for the clockwork drive
 15 off switch for the recording arm
 16 drum (recording drum)
 17 time scale
 18 case (housing)
 19 thermograph
 20 drum (recording drum)
 21 recording arm
 22 sensing element
 23 silver-disc (silver-disk) pyrheliometer, an instrument for measuring the sun's radiant energy
 24 silver disc (disk)
 25 thermometer
 26 wooden insulating casing
 27 tube with diaphragm (diaphragmed tube)
 28 wind gauge (Am. gage) (anemometer)
 29 wind-speed indicator (wind-speed meter)
 30 cross arms with hemi-

منطلقنا الأمطار المعتدلة
 مناخ شمالي (مناخ الغابة الجليدية)
 نوعا المناخ القطبي
 مناخ تندرا (القطب الشمالي)
 مناخ الصقيع المستمر
 أَجْهَزَةُ الأَرْضَادِ الجَوِّيَّةِ
 بارومتر زئبقي، بارومتر
 بعمود سائل
 عمود الزئبق
 مقياس المليبار
 باروجراف، 11 (مرسمة الضغط
 الجوي)
 طبلة/أسطوانة التسجيل
 مجموعة كبسولات لاسائلية
 ذراع التسجيل
 مرسمة الرطوبة الشسبية
 هيجرومتر شعري (مقياس
 الرطوبة الشسبية في الجو)
 معايرة القراءة
 معايرة / ضبط السعة
 ذراع التسجيل
 قلم التسجيل
 تروس التغيير الخاصة
 بحركة آلية الساعة
 زر الإيقاف الخاص بذراع
 التسجيل
 طبلة/أسطوانة التسجيل
 مقياس زمني
 غلاف/إطار تثبيت
 ترموجراف
 طبلة/أسطوانة التسجيل
 ذراع التسجيل
 عنصر الاستشعار
 بريليوميتر ذو قرص فضي
 (مقياس حرارة الإشعاع
 الشمسي)
 قرص فضي
 ترمومتر
 غلاف خشبي عازل
 أنبوب رقي
 مقياس سرعة الرياح
 مؤشر سرعة الرياح
 (مقياس سرعة الرياح)
 أذرع متعامدة مزودة

نهر أخدودي
أنواع الوديان [قطاع عرضي]
وادي عميق ضيق
وادي متفرج
وادي متفرج متسع
وادي غوري
وادي قيعري/التوالي
وادي النهري
جرف، منحدر شديد
منحدر انزلاقي
الميسا هضبة صغيرة
منسحجة ذات سفوح شديدة الانحدار
مرتفع صخري
نهر
سهل فيضي
شرفة نهريه
شرفة، شرفة صغيرة
رصيف صخري ثنائي
خفيف الانحدار، راحة، سد تل
قاع الوادي
قاع النهر
رواسب
صخر القاعدة
تكوين الكارست في الحجر الجيري
دحل، دولينا
البولج منخفض ممتدله
أرضية مسطحة وجدران
شديدة الانحدار وليس به
مجري مائي أرضي
تخلل/رشح نهر
نبع/عين الكارست
وادي جاف
بنظام الكهوف
مستوى الماء في تكوين الكارست
صخر غير منفذ
كهف من الحجر الجيري
رواسب معدنية ثانوية
تتكون في الكهوف
هابطة
صاعدة
صاعدة وهابطة متصلتان
نهر باطني

51 canyon river
52-56 types of valley [cross section]
52 gorge (ravine)
53 V-shaped valley (V-valley)
54 widened V-shaped valley
55 U-shaped valley (U-valley, trough valley)
56 synclinal valley
57-70 river valley
57 scarp (escarpment)
58 slip-off slope
59 mesa
60 ridge
61 river
62 flood plain
63 river terrace
64 terracette
65 pediment
66 hill
67 valley floor (valley bottom)
68 riverbed
69 sediment
70 bedrock
71-83 karst formation in limestone
71 dolina, sink (sink-hole, swallowhole)
72 polje
73 percolation of a river
74 karst spring
75 dry valley
76 system of caverns (system of caves)
77 water level (water table) in a karst formation
78 impervious rock (impermeable rock)
79 limestone cave (drip-stone cave)
80-81 speleothems (cave formations)
80 stalactite (dripstone)
81 stalagmite
82 linked-up stalagmite and stalactite
83 subterranean river

مستنقع (مستنقع ملح، هور)
مستنقع سبخ متخضض
طبقات مواد نباتية متعفنة
مياه محصورة
خث هوري
خث مستنقع جار الماء
مستنقع سبخ مرتفع
طبقة من طحالب الإسفنجوم
حديثة التكوين
الحدود الفاصلة بين الطبقات
طبقة من طحالب الإسفنجوم
أقدم في التكوين
بركة المستنقع
مستنقع
المرتفعات الصخرية
صخرة
بحر (محيط)
زبد
منحدر صخري، جرف
ركام صخري انهياي
تلمة
سلم/رصيف السحج
شعب حلقي مرجاني
بحيرة شاطئية صخلة
فتحة، ثغرة
شاطئ
علامة المد
أمواج تتكسر على الشاطئ
حاجز أمواج (المتع تآكل الشاطئ)
رأس حاجز الأمواج
كثيب رملي متقل
برخان، كثيب هلاي
علامات اليم
رطوبة، رابية
حاجز ريع
بحيرة ساحلية
وادي سحيق، هوة
هضبة
شرفة صخرية
صخرة رسوبية
شرفة نهريه
فلق، فلقه

14-24 bog (marsh)
14 low-moor bog
15 layers of decayed vegetable matter
16 entrapped water
17 fen peat [consisting of rush and sedge]
18 alder-swamp peat
19 high-moor bog
20 layer of recent sphagnum mosses
21 boundary between layers (horizons)
22 layer of older sphagnum mosses
23 bog pool
24 swamp
25-31 cliffline (cliffs)
25 rock
26 sea (ocean)
27 surf
28 cliff (cliff face, steep rock face)
29 scree
30 [wave-cut] notch
31 abrasion platform (wave-cut platform)
32 atoll, a ring-shaped coral reef
33 lagoon
34 breach (hole)
35-44 beach
35 high-water line (high-water mark, tidemark)
36 waves breaking on the shore
37 groyne (Am. groin)
38 groyne (Am. groin) head
39 wandering dune (migratory dune, traveling, Am. traveling, dune), a dune
40 barchan (barchane, barkhan, crescentic dune)
41 ripple marks
42 hummock
43 wind cripple
44 coastal lake
45 canyon (cañon, coulee)
46 plateau (tableland)
47 rock terrace
48 sedimentary rock stratified rock
49 river terrace (bed)
50 joint

طبقة غير منفذة
طبقة مسامية تقوم بدور صخر المحكم
غاز طبيعي (الغسوة غازية)
بتروول (زيت خام)
مياه تحبته
برج الحفر
منطقة جبلية
قمة جبلية مستديرة
نقوة جبلي
منحدر جبلي
نبع جانب المنحدر
إقليم جبلي مرتفع
سلسلة جبلية، كتلة جبلية
قمة الجبل
كتف
سرج
واجهة صخرية
شعب
ركام المنحدرات (هشيم)
ممن بري
ممر
الثلج الجليدي
حوض الثلج الجليدي
مقلجة الوادي
شور جليدي
خرطوم المتلجة
مجرى مائي أسفل المتلجة
ركام الجليد الجانبي
ركام الجليد الوسطي
ركام الجليد النهائي
مائدة جليدية
الجغرافية الطبيعية
(3)
طوبوغرافيا نهريه
منصب النهر
رافد (من نهر)
بحيرة
ضفة
شبه جزيرة (لسان ساحلي)
جزيرة
خليج
مجرى مائي
شط، شاطئ
سهل غربي
ميندر، منحطف
قلب المنحطف
أرض ممتدبة

an anticline
28 impervious stratum (impermeable stratum)
29 porous stratum acting as reservoir rock
30 natural gas, a gas cap
31 petroleum (crude oil)
32 underlying water
33 derrick
34 mountainous area
35 rounded mountain top
36 mountain ridge (ridge)
37 mountain slope
38 hillside spring
39-47 high-mountain region
39 mountain range, a massif
40 summit (peak, top of the mountain)
41 shoulder
42 saddle
43 rock face (steep face)
44 gully
45 talus (scree, detritus)
46 bridle path
47 pass (col)
48-56 glacial ice
48 firm field (firm basin, névé)
49 valley glacier
50 crevasse
51 glacier snout
52 subglacial stream
53 lateral moraine
54 medial moraine
55 end moraine
56 glacier table
13 Physical Geography III
1-13 fluvial topography
1 river mouth, a delta
2 distributary (distributary channel), a river branch (river arm)
3 lake
4 bank
5 peninsula (spit)
6 island
7 bay (cove)
8 stream (brook, rivulet, creek)
9 levee
10 alluvial plain
11 meander (river bend)
12 meander core (rock island)
13 meadow

زلال تحت البحر
قشرة مرتفعة
الجغرافية الطبيعية
(2)
الجيو لوجيا
تكون طبقات الصخور الرسوبية
متجه الطبقة
ميل الطبقة الأرضية بالشئبة إلى الأفق
نشوء الجبال
الجبال الإنكسارية
(الجبال الكتلية)
صدع، فالق
خط الصدع
رشيبة الصدع
صدع عادي
صدوع مركبة/معقدة
صدوع درجية/مدرجة
كتل مائلة
هضبة الدفاعية، ظهر
خسف، غور، أخدود
سلسلة جبال التوائية
طية متماثلة
طية غير متماثلة
طية منكئة
طية منطسجة
طية سرجية
محور الطية السحبية
طية مقعرة
محور الطية المقعرة
طية محدبة مركبة
مياه جوفية ارتوازية
طبقة خازنة للماء
صخر غير منفذ
حوض الصرف
بطر ارتوازية
نبع/عين ارتوازية
مكمن بتروول في طية محدبة

wave) produced by seaquake (submarine earthquake)
54 raised beach
12 Physical Geography II
1-33 geology
1 stratification of sedimentary rock
2 strike
3 dip (angle of dip, true dip)
4-20 orogeny (orogenesis, tectogenesis, deformation of rocks by folding and faulting)
4-11 fault-block mountain (block mountain)
4 fault
5 fault line (fault trace)
6 fault throw
7 normal fault (gravity fault, normal slip fault, slump fault)
8-11 complex faults
8 step fault (distributive fault, multiple fault)
9 tilt block
10 horst
11 graben
12-20 range of fold mountains (folded mountains)
12 symmetrical fold (normal fold)
13 asymmetrical fold
14 overfold
15 recumbent fold (reclined fold)
16 saddle (anticline)
17 anticlinal axis
18 trough (syncline)
19 trough surface (trough plane, synclinal axis)
20 anticlinorium
21 groundwater under pressure (artesian water)
22 water-bearing stratum (aquifer, aquafer)
23 impervious rock (impermeable rock)
24 drainage basin (catchment area)
25 artesian well
26 rising water, an artesian spring
27 petroleum reservoir in
682

14 Map I
1-7 graticule of the earth
 (network of meridians and parallels on the earth's surface)
 1 equator
 2 line of latitude (parallel of latitude, parallel)
 3 pole (North Pole or South Pole), \blacksquare terrestrial pole (geographical pole)
 4 line of longitude (meridian of longitude, meridian, terrestrial meridian)
 5 Standard meridian (Prime meridian, Greenwich meridian, meridian of Greenwich)
 6 latitude
 7 longitude
8-9 map projections
 8 conical (conic) projection
 9 cylindrical projection (Mercator projection, Mercator's projection)
10-45 map of the world
 10 tropics
 11 polar circles
12-18 continents
12-13 America
 12 North America
 13 South America
 14 Africa
15-16 Europe and Asia
 15 Europe
 16 Asia
 17 Australia
 18 Antarctica (Antarctic Continent)
19-26 ocean (sea)
 19 Pacific Ocean
 20 Atlantic Ocean
 21 Arctic Ocean
 22 Antarctic Ocean (Southern Ocean)
 23 Indian Ocean
 24 Strait of Gibraltar, a sea strait
 25 Mediterranean (Mediterranean Sea, European Mediterranean)
 26 North Sea, \blacksquare marginal sea (epeiric sea, epi-continental sea)
27-29 key (explanation of

الخريطة (1)
 شبكة خطوط الطول والعرض على الخريطة
 خط الاستواء
 خط عرض
 قطب (القطب الشمالي أو القطب الجنوبي)، قطب أرضي
 خط طول
 خط الزوال الرئيسي
 خريطة العالم
 المداران
 الأذرتان القطبيتان
 القارات
 أمريكا
 أمريكا الشمالية
 أمريكا الجنوبية
 أفريقيا
 أوروبا وآسيا
 أوروبا
 آسيا
 أستراليا
 أنتاركتيكا (القارة القطبية)
 المحيطات
 المحيط الهادسيك
 المحيط الأطلسي (الأطلنطي)
 المحيط القطبي الشمالي
 المحيط القطبي الجنوبي
 المحيط الهندي
 مضيق جبل طارق
 البحر الأبيض المتوسط
 بحر الشمال
 مفتاح الخريطة

map symbols)
 27 cold ocean current
 28 warm ocean current
 29 scale
30-45 ocean (oceanic) currents (ocean drifts)
 30 Gulf Stream (North Atlantic Drift)
 31 Kuroshio (Kuro Siwo, Japan Current)
 32 North Equatorial Current
 33 Equatorial Countercurrent
 34 South Equatorial Current
 35 Brazil Current
 36 Somali Current
 37 Agulhas Current
 38 East Australian Current
 39 California Current
 40 Labrador Current
 41 Canary Current
 42 Peru Current
 43 Benguela (Benguella) Current
 44 West Wind Drift (Antarctic Circumpolar Drift)
 45 West Australian Current
46-62 surveying (land surveying, geodetic surveying, geodesy)
 46 levelling (*Am.* leveling)
 47 graduated measuring rod (levelling, *Am.* leveling, staff)
 48 level (surveying level, surveyor's level), a surveyor's telescope
 49 triangulation station (triangulation point)
 50 supporting scaffold
 51 signal tower (signal mast)
52-62 theodolite, an instrument for measuring angles
 52 micrometer head
 53 micrometer eyepiece
 54 vertical tangent screw
 55 vertical clamp
 56 tangent screw
 57 horizontal clamp
 58 adjustment for the illuminating mirror

مراة مضيئة
 تلسكوب
 ميزان شوية
 معايرة دائرية
63-66 photogrammetry (photopography)
 كاميرا مسح جوي لالتقاط مجموعات متراكبة من الصور
 ستريوسكوب، ميسام بانوجراف، ميساخ ستريوبلانيجراف
15 Map II
1-114 map signs (map symbols, conventional signs) on a 1:25 000 map
 1 coniferous wood (coniferous trees)
 2 clearing
 3 forestry office
 4 deciduous wood (non-coniferous trees)
 5 heath (rough grassland, rough pasture, heath and moor, bracken)
 6 sand or sand hills
 7 beach grass
 8 lighthouse
 9 mean low water
 10 beacon
 11 submarine contours
 12 train ferry
 13 lightship
 14 mixed wood (mixed trees)
 15 brushwood
 16 motorway with slip road (*Am.* freeway with on-ramp, freeway with acceleration lane)
 17 trunk road
 18 grassland
 19 marshy grassland
 20 marsh
 21 main line railway (*Am.* trunk line)
 22 road over railway
 23 branch line
 24 signal box (*Am.* switch tower)
 25 local line
 26 level crossing
 27 halt
 28 residential area
 29 water gauge (*Am.* gage)
 30 good, metalled road

طاحونة هوائية
 بيت الزغور (بحيرة ملحية، ملاحه)
 محطة إذاعة (برج بث لاسلكي أو تلفزيوني)
 منجم
 منجم مهجور
 طريق ثانوي
 مصنع
 مدخنة
 سياج سلكي
 جسر فوق سكة حديدية
 محطة سكة حديدية
 جسر أسفل سكة حديدية
 ممر المشاة
 جسر مشاة أسفل سكة حديدية
 نهر ملاح
 جسر عالم (على أطواف)
 معدنية
 حاجز أمواج
 فتار (المياه الضحلة)
 جسر حجري
 بلدة أو مدينة
 منطقة السوق
 كنيسة ضخمة ذات برجين
 مبنى حكومي
 جسر عبور الطريق
 جسر حديدي
 قناة
 هويس
 رصيف بحري
 معدنية ركاب
 أبرشية بدون برج أو قمة هوائية
 خطوط كتوروية، مناسب
 دير
 معلم كنيسة
 كرم
 سد صغير
 طريق جبلي هوائي
 برج الروية
 سد
 نفق
 نقطة التثليث
 أنقاض مبنى
 مضخة نثار بالرياح
 قلعة، حصن
 بحيرة قوسية الشكل
 نهر
 طاحونة مائية

78 footbridge	جسر عبور المشاة
79 pond	بركة
80 stream (brook, rivulet, creek)	نهر، مجرى مائي
81 water tower	برج خزانات الماء
82 spring	جذول مياه، عين مياه
83 main road (A road)	طريق رئيسي
84 cutting	نقح غير مسقوف
85 cave	كهف
86 lime kiln	قمين جير
87 quarry	مخجر
88 clay pit	خفرة طين
89 brickworks	مصنع طوب
90 narrow-gauge (Am. narrow gage) railway	سكة حديدية ضيقة
91 goods depot (freight depot)	مستودع بضائع
92 monument	نصب تذكاري
93 site of battle	موقع معركة
94 country estate, a demesne	ضيعة أو عزبة
95 wall	جدار، سور
96 stately home	مزل فاخر
97 park	منتزه
98 hedge	سياج
99 poor or unmetalled road	طريق غير معبد
100 well	بئر
101 farm	مزرعة
102 unfenced path (unfenced track)	ممر غير مسجج
103 district boundary	حدود الضاحية
104 embankment	سد
105 village	قرية
106 cemetery	مدافن، جبانة
107 church or chapel with spire	كنيسة قبتها هرمية
108 orchard	بستان
109 milestone	علم الطريق
110 guide post	لافتة الطريق
111 tree nursery	شتل أشجار
112 ride (aisle, lane, section line)	ممر، درب
113 electricity transmission line	خط نقل الكهرباء
114 hop garden	حديقة خشيشة الدينار
16 Man I	الإنسان (1)
1-54 the human body	جسم الإنسان
1-18 head	الرأس
1 vertex (crown of the head, top of the head)	قمة الرأس
2 occiput (back of the head)	القدال، القفا، مؤخرة الرأس
3 hair	شعر
4-17 face	الوجه
4-5 forehead	الجبهة
4 frontal eminence (frontal protuberance)	بروز الجبهة
5 superciliary arch	القوس فوق الهدبي
6 temple	صدغ
7 eye	عين
8 zygomatic bone (malar bone, jugal bone, cheekbone)	العظم الوجني
9 cheek	وجحة
10 nose	أنف
11 nasolabial fold	ثنية أنف-شفوية
12 philtrum	ثزملة، النثرة
13 mouth	فم
14 angle of the mouth (labial commissure)	زاوية الفم
15 chin	ذقن
16 dimple (fossette) in the chin	غمازة، ثقرة في الذقن
17 jaw	فك
18 ear	أذن
19-21 neck	الرقبة/العنق
19 throat	الزور
20 hollow of the throat	وقرة الزور
21 nape of the neck	قفا الرقبة
22-41 trunk	الجذع
22-25 back	الظهر
22 shoulder	كتف
23 shoulderblade (scapula)	لوح الكتف
24 loins	خاصرة
25 small of the back	القطن
26 armpit	إبط
27 armpit hair	شعر الإبط
28-30 thorax (chest)	الصدر
28-29 breasts (breast, mamma)	الثديان
28 nipple	حلمة
29 areola	لغوة، هالة
30 bosom	مكتشف الصدر
31 waist	خصر
32 flank (side)	جنب
33 hip	ورك
34 navel	سرة
35-37 abdomen (stomach)	البطن
35 upper abdomen	الجزء العلوي من البطن، قم المعدة
36 abdomen	بطن
37 lower abdomen	الجزء السفلي من البطن
38 groin	الأربية، المقين
39 pudenda (vulva)	أعضاء التماسل الخارجية
40 seat (backside, coll. bottom)	مقعدة
41 anal groove (anal cleft)	الحز الإشتي
42 gluteal fold (gluteal furrow)	الثنية الألوية
43-54 limbs	الأطراف
43-48 arm	الذراع
43 upper arm	عضد
44 crook of the arm	ثنية الذراع
45 elbow	مرفق
46 forearm	ساعد
47 hand	يد

48 fist (clenched fist, clenched hand)	قبضة
49-54 leg	الساق
49 thigh	فخذ
50 knee	ركبة
51 popliteal space	باطن الركبة
52 shank	الرجل
53 calf	بطن الساق، السمانة
54 foot	قدم

17 Man II

1-29 skeleton (bones)	الهيكلة العظمي (العظام)
1 skull	الجمجمة
2-5 vertebral column (spinal column, spine, backbone)	العمود الفقاري
2 cervical vertebra	فقرة عنقية
3 dorsal vertebra (thoracic vertebra)	فقرة ظهرية
4 lumbar vertebra	فقرة قطنية
5 coccyx (coccygeal vertebra)	المصنص
6-7 shoulder girdle	الحزام الكتفي
6 collarbone (clavicle)	عظم الترقوة (الترقوة)
7 shoulderblade (scapula)	لوح الكتف
8-11 thorax (chest)	الصدر
8 breastbone (sternum)	عظم القصر
9 true ribs	ضلع حقيقي
10 false ribs	ضلع كاذبة
11 costal cartilage	غضروف ضلعي
12-14 arm	الذراع
12 humerus	العظم
13 radius	الكعبرة
14 ulna	الزند
15-17 hand	اليدين
15 carpus	الرسغ
16 metacarpal bone (metacarpal)	العظام السعوية
17 phalanx (phalange)	سلاحيات
18-21 pelvis	الحوض
18 ilium (hip bone)	الترقفة
19 ischium	الورك
20 pubis	العانة
21 sacrum	العجز
22-25 leg	الساق
22 femur (thigh bone, thigh)	عظم الفخذ
23 patella (kneecap)	الرضفة (صابونة الركبة)
24 fibula (splint bone)	الشيطة
25 tibia (shinbone)	الظنوب
26-29 foot	القدم
26 tarsal bones (tarsus)	عظم رضع (رضع القدم)
27 calcaneum (heelbone)	العقب
28 metatarsus	العظام المشطية
29 phalanges	السلاحيات
30-41 skull	الجمجمة
30 frontal bone	العظم الجبهي
31 left parietal bone	العظم الجداري الأيسر
32 occipital bone	العظم القذالي

33 temporal bone	العظم الصدغي
34 external auditory canal	قناة السمع الخارجية
35 lower jawbone (lower jaw, mandible)	الفك السفلي
36 upper jawbone (upper jaw, maxilla)	الفك العلوي
37 zygomatic bone (cheekbone)	العظم الوجني
38 sphenoid bone (sphenoid)	العظم الوتدي
39 ethmoid bone (ethmoid)	العظم المصفوي
40 lacrimal (lacrima) bone	العظم الدمعي
41 nasal bone	العظم الأنفي
42-55 head [section]	الرأس [مقطع]
42 cerebrum (great brain)	المخ
43 pituitary gland (pituitary body, hypophysis cerebri)	الغدة النخامية
44 corpus callosum	الجسم الثقني
45 cerebellum (little brain)	المخخ
46 pons (pons cerebri, pons cerebelli)	جسر المخخ
47 medulla oblongata (brain stem)	التخاع الشوكي
48 spinal cord	الحبل الشوكي
49 oesophagus (esophagus, gullet)	الغريء
50 trachea (windpipe)	القضية الهوائية
51 epiglottis	لسان المزمار
52 tongue	اللسان
53 nasal cavity	التجويف الأنفي
54 sphenoidal sinus	الجيب الوتدي
55 frontal sinus	الجيب الجبهي
56-65 organ of equilibrium and hearing	عضو التوازن والسمع
56-58 external ear	الأذن الخارجية
56 auricle	صوان الأذن
57 ear lobe	فصيص الأذن
58 external auditory canal	قناة السمع الخارجية
59-61 middle ear	الأذن الوسطى
59 tympanic membrane	طبلة الأذن، الغشاء الطبلي
60 tympanic cavity	التجويف الطبلي
61 auditory ossicles: hammer, anvil, and stirrup (malleus, incus, and stapes)	عظيئات السمع المطرقة والسندان والركاب
62-64 inner ear (internal ear)	الأذن الداخلية
62 labyrinth	التيه
63 cochlea	القوقعة
64 auditory nerve	العصب السمعي
65 eustachian tube	قناة استاكوس
18 Man III	الإنسان (3)
1-21 blood circulation (circulatory system)	الدورة الدموية (الجهاز الدوري)
1 common carotid artery,	شريان سباتي عادي

2	an artery	وَرِيدٌ وَدَجِي
2	jugular vein, a vein	شُرَيَانٌ صَدَاقِي
3	temporal artery	وَرِيدٌ صَدَاقِي
4	temporal vein	شُرَيَانٌ جِهَتِي
5	frontal artery	وَرِيدٌ جِهَتِي
6	frontal vein	الشُرَيَانُ تَحْتَ التَّرْقَوِي
7	subclavian artery	الوَرِيدُ تَحْتَ التَّرْقَوِي
8	subclavian vein	الوَرِيدُ الأَجْوْفِ العُلوي
9	superior vena cava	الأورطي، الأَتهَر
10	arch of the aorta (aorta)	الشُرَيَانُ الرَّئَوِي [وَبِهِ دَمٌ وَرِيدِي]
11	pulmonary artery [with venous blood]	الوَرِيدُ الرَّئَوِي [وَبِهِ دَمٌ شُرَيَانِي]
12	pulmonary vein [with arterial blood]	الرئتان
13	lungs	القلب
14	heart	الوَرِيدُ الأَجْوْفِ السفلي
15	inferior vena cava	الأورطي البطني
16	abdominal aorta (descending portion of the aorta)	الشُرَيَانُ الخُرْفَقِي
17	iliac artery	الوَرِيدُ الخُرْفَقِي
18	iliac vein	الشُرَيَانُ الفَخْذِي
19	femoral artery	الشُرَيَانُ الظَّنْبُوبِي
20	tibial artery	الشُرَيَانُ الكَعْبَرِي
21	radial artery	الجهاز العصبي
22-33	nervous system	المخ
22	cerebrum (great brain)	المخخ
23	cerebellum (little brain)	السُّخَاعُ الفُوقِي
24	medulla oblongata (brain stem)	الجذع الشوكي
25	spinal cord	الأغصاب الصدرية
26	thoracic nerves	الضفيرة العَضَدِيَّة
27	brachial plexus	العصب الكَعْبَرِي
28	radial nerve	العصب الزندي
29	ulnar nerve	العصب الوركي
30	great sciatic nerve (lying posteriorly)	العصب الفخذي
31	femoral nerve (anterior crural nerve)	العصب الظَّنْبُوبِي
32	tibial nerve	العصب السُّطُوي
33	peroneal nerve	الجهاز العضلي
34-64	musculature (muscular system)	العضلة القَصِيَّةُ التَّرْقَوِيَّةُ
34	sternocleidomastoid muscle (sternomastoid muscle)	الحلمية
35	deltoid muscle	العضلة الدالية
36	pectoralis major (greater pectoralis muscle, greater pectoralis)	العضلة الصدرية الكبرى
37	biceps brachii (biceps of the arm)	العضلة ذات الرأسين
38	triceps brachii (triceps of the arm)	العضلة ذات الثلاثة رؤوس
39	brachioradialis	العضدية
40	flexor carpi radialis (radial flexor of the wrist)	العضلة العَضَدِيَّةُ الكَعْبَرِيَّةُ
41	thenar muscle	العضلة مَثْبِيَّةُ الرَّسْغِ الكَعْبَرِيَّةُ
		العضلة الرَّاحِيَّةُ

42	serratus anterior	العضلة المَسْتَقِيمةُ الأمامية
43	obliquus externus abdominis (external oblique)	العضلة الخارجية المائلة
44	rectus abdominis	العضلة المستقيمة البطنية
45	sartorius	العضلة الخياطية
46	vastus lateralis and vastus medialis	العضلة المُشْعَبة الوحشية والعضلة المُشْعَبة الإنسية
47	tibialis anterior	العضلة الظنبوبية الأمامية
48	tendo calcaneus (Achilles' tendon)	الوتر العقبى
49	abductor hallucis (abductor of the hallux), a foot muscle	العضلة متباعدة إبهام القدم
50	occipitalis	العضلة القذالية
51	splenius of the neck	العضلة الفلاجية العنقية
52	trapezius	العضلة شبه المتحرفة
53	infraspinatus	العضلة تحت الشوكية
54	teres minor (lesser teres)	العضلة المدورة الصغرى
55	teres major (greater teres)	العضلة المدورة الكبرى
56	extensor carpi radialis longus (long radial extensor of the wrist)	العضلة باسطة الرسغ الكعبرية الطويلة
57	extensor communis digitorum (common extensor of the digits)	العضلة الباسطة الموصلة للأصابع
58	flexor carpi ulnaris (ulnar flexor of the wrist)	العضلة مثنية الرسغ الكعبرية
59	latissimus dorsi	العضلة العريضة الظهرية
60	gluteus maximus	العضلة الأليوية الكبرى
61	biceps femoris (biceps of the thigh)	العضلة ذات الرأسين الفخذية
62	gastrocnemius, medial and lateral heads	العضلة التوأمية للساق
63	extensor communis digitorum (common extensor of the digits)	العضلة الباسطة الموصلة لأصابع القدم
64	peroneus longus (long peroneus)	العضلة الشظوية الطويلة
19	Man IV	الإنسان (4)
1-13	head and neck	الرأس والعنق
1	sternocleidomastoid muscle (sternomastoid muscle)	العضلة القَصِيَّةُ التَّرْقَوِيَّةُ الحلمية
2	occipitalis	العضلة القذالية
3	temporalis (temporal, temporal muscle)	العضلة الصدغية
4	occipito frontalis (frontalis)	العضلة القذالية الجبهية
5	orbicularis oculi	العضلة الدويرية العينية
6	muscles of facial expression	عضلات الوجه
7	masseter	العضلة الماضضة
8	orbicularis oris	العضلة الدويرية الفغوية
9	parotid gland	الغدة الكفية

10	lymph node (sub-mandibular lymph gland)	العقدة الليمفية
11	submandibular gland (submaxillary gland)	الغدة تحت الفك السفلية
12	muscles of the neck	عضلات الرقبة
13	Adam's apple (laryngeal prominence) [in men only]	تفاحة آدم [في الرجال فقط]
14-37	mouth and pharynx	الفم والروء
14	upper lip	الشفة العليا
15	gum	اللثة
16-18	teeth (set of teeth)	الأسنان
16	incisors	الفرواطع
17	canine tooth (canine)	ناب
18	premolar (bicuspid) and molar teeth (pre-molars and molars)	المواحين والمضواحك
19	angle of the mouth (labial commissure)	زاوية الفم
20	hard palate	الحنك الصلب
21	soft palate (velum palati, velum)	الحنك الرخو
22	uvula	عضلة اللهاة
23	palatine tonsil (tonsil)	لوزة
24	pharyngeal opening (pharynx)	فتحة البلعوم
25	tongue	اللسان
26	lower lip	الشفة السفلى
27	upper jaw (maxilla)	الفك العلوي
28-37	tooth	سن
28	periodontal membrane (periodontium, pericementum)	العشاء حول السني
29	cement (dental cementum, crusta petrosa)	الملاط
30	enamel	المينا
31	palatine (dentin)	الغاج
32	dental pulp (tooth pulp, pulp)	اللب السني
33	nerves and blood vessels	الأغصاب والأوعية الدموية
34	incisor	قاطع
35	molar tooth (molar)	خِيس، طاحن
36	root (fang)	جذر، جذمور
37	crown	تاج
38-51	eye	العين
38	eyebrow (supercilium)	حاجب
39	upper eyelid (upper palpebra)	جفن علوي
40	lower eyelid (lower palpebra)	جفن سفلي
41	eyelash (cilium)	رمش، هذب
42	iris	القزحية
43	pupil	الخطقة
44	eye muscles (ocular muscles)	عضلات العين
45	eyeball	العقلة

46	vitreous body	الجسم الزجاجي
47	cornea	القزحية
48	lens	العدسة
49	retina	الشبكية
50	blind spot	البقعة العمياء
51	optic nerve	عصب بصري
52-63	foot	القدم
52	big toe (great toe, first toe, hallux, digitus I)	إبهام القدم
53	second toe (digitus II)	الإصبع الثاني
54	third toe (digitus III)	الإصبع الثالث
55	fourth toe (digitus IV)	الإصبع الرابع
56	little toe (digitus minimus, digitus V)	الإصبع الصغير
57	toenail	ظفر إصبع القدم
58	ball of the foot	الضرة
59	lateral malleolus (external malleolus, outer malleolus, malleolus fibulae)	الثوء الكعبي الوحشي
60	medial malleolus (internal malleolus, inner malleolus, malleolus tibulae, malleolus medialis)	الثوء الكعبي الوحشي الأسي
61	instep (medial longitudinal arch, dorsum of the foot, dorsum pedis)	وجه القدم
62	sole of the foot	إخمس القدم
63	heel	عقب، كعب
64-83	hand	اليد
64	thumb (pollex, digitus I)	الإبهام
65	index finger (fore-finger, second finger, digitus II)	السبابة
66	middle finger (third finger, digitus medius, digitus III)	الوسطى
67	ring finger (fourth finger, digitus anularis, digitus IV)	البنصر
68	little finger (fifth finger, digitus minimus, digitus V)	الخنصر
69	radial side of the hand	الجانب الكعبري لليد
70	ulnar side of the hand	الجانب الزندي لليد
71	palm of the hand (palma manus)	راحة اليد
72-74	lines of the hand	خطوط الكف
72	life line (line of life)	خط العُمر
73	head line (line of the head)	خط الرأس
74	heart line (line of the heart)	خط القلب
75	ball of the thumb (thenar eminence)	كرة اليد
76	wrist (carpus)	رُسع
77	phalanx (phalange)	سلاميات
78	finger pad	لينة الأصابع

الجيرة	screw
ضمادة ضغط	17 compression bandage
إنقاذ ونقل الشخص المصاب	18-23 rescue and transport of an injured person
سكة "راوتك" لإنقاذ ضحية في حادث سيارة)	18 Rautek grip (for rescue of a car accident victim)
مساعد	19 helper
شخص مصاب	20 injured person (casualty)
سكة المقعد	21 chair grip
سكة الحمل	22 carrying grip
نقالة طوارئ مصنوعة من عصى وسرة	23 emergency stretcher of sticks and a jacket
الوضع الصحيح للشخص فاقد الوعي والتنفس الصناعي (إنعاش القلب والرئتين)	24-27 positioning of an unconscious person and artificial respiration (resuscitation)
وضع العنقوبة	24 coma position
شخص فاقد الوعي	25 unconscious person
إنعاش القلب والرئتين عن طريق الفم (قبة الحياة)	26 mouth-to-mouth resuscitation (variation: mouth-to-nose resuscitation)
جهاز إنعاش القلب والرئتين ، جهاز تنفس صناعي	27 resuscitator (respiratory apparatus, resuscitation apparatus), a respirator (artificial breathing device)
طريقة الإنقاذ في حوادث الجليد	28-33 methods of rescue in ice accidents
الشخص الذي سقط في انهيار الجليد	28 person who has fallen through the ice
المقعد	29 rescuer
حبل	30 rope
طاولة (أو ما شابه ذلك)	31 table (or similar device)
سلم	32 ladder
إنقاذ ذاتي	33 self-rescue
إنقاذ غريق	34-38 rescue of a drowning person
طريقة تحرر المقعد من الغريق	34 method of release (release grip, release) to free rescuer from the clutch of a drowning person
الغريق	35 drowning person
المنقذ	36 lifesaver
القطر	37, 38 towing (tows)
سكة الظهر المزدوجة من الكتفين	37 double shoulder tow
سكة الظهر من الرأس	38 head tow
الطبيب (1) عيادة الطبيب	22 Doctor I 1-74 general practice (Am. physician's office)
غرفة الانتظار	1 waiting room
مريض	2 patient

79 fingertip	طَرَف الإِصْبَع	34-35 liver [from behind]	الكَبِد [من الخلف]
80 fingernail (nail)	ظفر الإِصْبَع	34 falciiform ligament of the liver	الرِّبَاط المَنْجَلِي للكَبِد
81 lunule (lunula) of the nail	هَيْكَل الظَّفَر	35 lobe of the liver	فص الكَبِد
82 knuckle	عُقْلَة	36 gall bladder	الحَوْصَلَة الصَّفْرَاوِيَة
83 back of the hand (dorsum of the hand, dorsum manus)	ظَهْر اليَد	37-38 common bile duct	القَنَاة الصَّفْرَاوِيَة
		37 hepatic duct (common hepatic duct)	القَنَاة الكَبِدِيَة
		38 cystic duct	القَنَاة الحَوْصَلِيَة
20 Man V	الإنسان (5)	39 portal vein (hepatic portal vein)	الوَرِيد الكَبِدِي (البَابِي)
1-57 internal organs [front view]	الأعضاء الداخلية [منظَر أمامي]	40 esophagus (esophagus, gullet)	العُرْيَة
1 thyroid gland	العُدَّة الدَّرْقِيَة	41-42 stomach	المَعْدَة
2-3 larynx	الْحَنَجرَة	41 cardiac orifice	فَتْحَة القَوَاد
2 hyoid bone (hyoid)	العَظْم اللَامِي	42 pylorus	البُوب
3 thyroid cartilage	عُضْرُوف دَرَقِي	43 duodenum	الإِثْنَا عَشْرِي
4 trachea (windpipe)	القَصْبَة الهَوَائِيَة	44 pancreas	الْبَنكرياس
5 bronchus	شُعْبَة هَوَائِيَة	45-57 heart (longitudinal section)	الْقَلْب (مَقْلَع طُولِي)
6 right lung	الرِئَة اليَمْنِي	45 atrium	أُذُن القَلْب
7 upper pulmonary lobe (upper lobe of the lung) [section]	الفص الصُدْرِي الرُّوئِي العُلْوِي [مَقْلَع]	46-47 valves of the heart	صِمَامَات القَلْب
8 heart	القَلْب	46 tricuspid valve (right atrioventricular valve)	الصِمَام ثَلَاثِي الشَّرْف
9 diaphragm	الجِجَاب الحَاجِز	47 bicuspid valve (mitral valve, left atrioventricular valve)	الصِمَام ثَنَائِي الشَّرْف (المِيعْرَالِي)
10 liver	الكَبِد	48 cusp	شُرْفَة
11 gall bladder	الحَوْصَلَة الصَّفْرَاوِيَة	49 aortic valve	صِمَام الأَبْهَر
12 spleen	الطَّحَال	50 pulmonary valve	صِمَام رُفْوِي
13 stomach	المَعْدَة	51 ventricle	بَئِطِي
14-22 intestines (bowel)	الإِمْعَاء	52 ventricular septum (interventricular septum)	حَاجِز بَئِطِي
14-16 small intestine (intestinum tenue)	الإِمْعَاء الرَيفِيَة	53 superior vena cava	الوَرِيد الأَجُوف العُلْوِي
14 duodenum	الإِثْنَا عَشْرِي	54 aorta	الوَرِيد الأَوْرطِي
15 jejunum	الصَّائِم	55 pulmonary artery	الشَّرْيَان الرُّوئِي
16 ileum	الفَلَائِي	56 pulmonary vein	وَرِيد رُفْوِي
17-22 large intestine (intestinum crassum)	الإِمْعَاء العَظِيْمَة	57 inferior vena cava	الوَرِيد الأَجُوف السُّفْلِي
17 caecum (cecum)	الأَعْوَر	58 peritoneum	البَرِيْتُون ، الغِشَاء البَرِيْتُونِي
18 appendix (vermiform appendix)	الزَّرَائِيْدَة الدُّوْبِيَة	59 sacrum	العَجز
19 ascending colon	القَوَلُون الصَّاعِد	60 coccyx (coccygeal vertebra)	المُصْصَع
20 transverse colon	القَوَلُون السُّنْعَرَض	61 rectum	المُسْتَقِيم
21 descending colon	القَوَلُون السَّارِل	62 anus	الشَّرْج
22 rectum	المُسْتَقِيم	63 anal sphincter	العَضَلَة المَصْرَة الشَّرْجِيَة
23 oesophagus (esophagus, gullet)	العُرْيَة	64 perineum	العِجَان
24, 25 heart	القَلْب	65 pubic symphysis (symphysis pubis)	الارتِثَاق العَانِي
24 auricle	صِيَوَان	66-77 male sex organ [longitudinal section]	الأعضاء التناسلية للذكور [مَقْلَع طُولِي]
25 anterior longitudinal cardiac sulcus	ثَم أمامي طُولِي	66 penis	القَضْبِي
26 diaphragm	الجِجَاب الحَاجِز	67 corpus cavernosum and spongiosum of the penis (erectile tissue of the penis)	تَرَابِيق الأَجْسَام الكَهْفِيَة والإِسْفِنْجِيَة للقَضْبِي
27 spleen	الطَّحَال	68 urethra	المِثَال
28 right kidney	الكَبِدَة اليَمْنِي	69 glans penis	حَشْفَة القَضْبِي
29 suprarenal gland	العُدَّة فُوق الكَلْبَرِيَة	70 prepuce (foreskin)	القَلْفَة
30-31 left kidney [longitudinal section]	الكَلْبَة المِيسْرِي [مَقْلَع طُولِي]		
30 calyx (renal calyx)	كَأْس		
31 renal pelvis	حَوْض الكَلْبِيْن		
32 ureter	حَالِب		
33 bladder	المِثَانَة		

3 patients with appointments (for a routine check-up or renewal of prescription) مَرْضَى بِمَوَاعِدٍ مُسَبَّقةٍ (لفحص دوري أو استشارة)

4 magazines [for waiting patients] مجلّات

5 reception الاستقبال

6 patients file ملف المَرْضَى

7 eliminated index cards بطاقات مَهفُوسَة مَطْرُوحَة جَانِباً

8 medical record (medical card) سِجِلٌ طِبّي

9 health insurance certificate شهادة تَأْمِينِ صِحّي

10 advertising calendar (publicity calendar) رُوْزَنَامَة تجارِيَة للدعاية

11 appointments book دَفْتَرُ حِجْرِ المَوَاعِدِ

12 correspondence file ملف المراسلات

13 automatic telephone answering and recording set (telephone answering device) جِهَانٌ لِلاْرْتِدَاءِ عَلَى المكالَمَاتِ الهاتِفِيَة وَتَسْجِيلِهَا أَيْضاً

14 radiophone سَمَاعَة داخِلِيَة

15 microphone مَكْبَرُ الصَوْتِ

16 illustrated chart رَسْمٌ تخطيطي مَصُوْرٌ

17 wall calendar رُوْزَنَامَة حائط

18 telephone هاتف، تليفون

19 [doctor's] assistant مساعد/مساعدة [الطبيب]

20 prescription رُوْشِيَة، مَذْكُرَة طِبِيَة

21 telephone index فِهْرَسُ التليفون

22 medical dictionary قاموس طبي

23 pharmacopoeia (list of registered medicines) قَائِمَة العُقَاظِيْرِ وَالأدوية المَسْجَلَة

24 franking machine (Am. postage meter) ماكِينَة دَمْعِ الرُّسَائِلِ

25 stapler دِبَّاسَة

26 diabetics file ملف السُكْرَى

27 dictating machine المِمْلاَة

28 paper punch خِرَامَة وَرَق

29 doctor's stamp خَاتَمُ الطَّبِيبِ

30 ink pad حَبَاة الخاتَمِ

31 pencil holder حَامِلُ أَقْلَامِ

32-74 surgery الجراحة

32 chart of eyegrounds رَسْمٌ تخطيطي لِقَاعِ العَيْنِ

33 doctor's bag (doctor's case) حَقِيْبَة الطَّبِيبِ

34 intercom جِهَانٌ اتِّصَالِ داخِلِي (التركوم)

35 medicine cupboard مِمْبَلِيَة مِمْبَلِيَة

36 swab dispenser وِعَاءٌ رَمِي القِطِيْلَة

37 inflator (Poltizer bag) حَقِيْبَة البُلُوْرَة

38 electrotome مَقْطَعٌ كَهْرَبائي

39 steam sterilizer جِهَانٌ تَعْقِيمِ بِالْبَخَارِ

40 cabinet خِرَامَة، صَوَان

41 medicine samples (from the pharmaceutical industry) مِيزَانُ أَطْفَالِ رَضَعٍ

42 baby scales مِيزَانُ أَطْفَالِ رَضَعٍ

43 examination couch سُرِيرُ الفَحْصِ

44 directional lamp مصباح مَتَحَرِّكٌ

45 instrument table طَاوِلَة الأَدْوَاتِ

46 tube holder حَامِلُ أَنْبَابِ

47 tube of ointment أَنْبُوبُ مَرْهَمٍ

48-50 instruments for minor surgery أدوات الجراحة البسيطة

48 mouth gag أداة فَتْحِ الفَمِ

49 Kocher's forceps مِجْرَفَة "كوتشر"

50 scoop (urette) مِجْرَفَة

51 angled scissors مَقْصٌ طَرَفُهُ مائل بِزاوِيَة

52 forceps مِجْرَفَة، مَلْقاط

53 olive-pointed (bulb-headed) probe مِجْرَسٌ ذُو رَأْسٍ مَتَفَخِّعٍ

54 syringe for irrigations of the ear or bladder مِخْطَنٌ تَغْضِيبِ الأذُنِ أو المِثانة

55 adhesive plaster شَرِيْبَةٌ لاصِق، بِلَاسْتَر (sticking plaster)

56 surgical suture material خِيطُ جِراحَة

57 curved surgical needle إِبْرَة طِبِيَة مَنْحَنِيَة

58 sterile gauze شاش مَعْقَمٌ

59 needle holder حَامِلُ الإِبْرِ

60 spray for disinfecting the skin رَشَّاشٌ لِتَطْهِيْرِ الجِلْدِ

61 thread container حاوِيَة الخِيطِ

62 ophthalmoscope مِظْطَارُ الكَشْفِ عَلَى العَيْنِ

63 freezer for cryosurgery فِرِيْزِرٌ لِجِراحَاتِ القَرْنِيَة

64 dispenser for plasters and small pieces of equipment سَلَّةٌ مَهْمَلَاتٍ لِلاشْرَطَة وَالأصْغَرِ وَالمُخَلَّفَاتِ الصغِيرَة

65 disposable hypodermic needles and syringes سَلَّةٌ مَهْمَلَاتِ الحَقْنِ وَالإِبْرِ تَحْتَ الجِلْدِيَة

66 scales, sliding-weight scales مِيزَانٌ (مِيزَانٌ ذُو ثِقَلٍ مَتَزَلِقٍ)

67 weighing platform مِمْصَة الوَظْنِ

68 sliding weight (jockey) ثِقَلٌ انزلاقي/مَتَحَرِّكٌ

69 height gauge (Am. gage) مِقْيَاسُ الطُولِ

70 waste bin (Am. trash bin) سَلَّةٌ مَهْمَلَاتِ

71 hot-air sterilizer جِهَانٌ تَعْقِيمِ بِالهَوَاءِ الساخِنِ

72 pipette مِمْصَة

73 percussor مِطْرَقَة

74 aural speculum مِظْطَارُ جَوْفِي لِالأذُنِ (مِظْطَارُ الأذُنِ، مِخْطَنُ الأذُنِ)

23 Doctor II (2) الطَّبِيبُ (2)

1 consulting room غُرْفَة الفَحْصِ

2 general practitioner مُمَارِسُ عَامِ

3-21 instruments for gynaecological and proctological examinations أَنْوَاتُ فَحْصِ أَمْرَاضِ النِّسَاءِ وَالمُسْتَقِيمِ

3 warming the instruments up to body temperature تَدْفِئَة الأَدْوَاتِ إِلَى دَرَجَة حَرارةِ الجِسمِ

4 examination couch سُرِيرُ الفَحْصِ

5 colposcope مِظْطَارُ المِهْبَلِ

6 binocular eyepiece عَيْنِيَة المِظْطَارِ

7 miniature camera كاميرا صغِيرَة

8 cold light source مِصْدَرُ ضَوْءٍ بارِدٍ

9 cable release زَرٌّ تَحْرِيرِ الكَبَلِ

10 bracket for the leg support كَتِيفَة تَثْبِيْتِ الساقِينِ

11 leg support (leg holder) حَامِلُ الساقِ

12 holding forceps (sponge holder) جِفتٌ لِمَسَاكِ الإسْفِنْجِ

13 vaginal speculum مِظْطَارُ جَوْفِي مِهْبَلِي

14 lower blade of the vaginal speculum اللُّوْحُ السْفَلِي لِلمِظْطَارِ الجَوْفِي المِهْبَلِي

15 platinum loop (for smears) لُوْلُبٌ بِلاتيني

16 rectoscope مِظْطَارُ المُسْتَقِيمِ

17 biopsy forceps used with the rectoscope (proctoscope) جِفتٌ لأَخْذِ العَيَّةِ المُسْتَحْدَمِ مَعَ مِظْطَارِ المُسْتَقِيمِ

18 insufflator for proctoscopy (rectoscopy) مِغْفَاجٌ تَنْظِيْرِ المُسْتَقِيمِ

19 proctoscope (rectal speculum) مِظْطَارُ جَوْفِي لِلمُسْتَقِيمِ

20 urethroscope مِظْطَارُ الإِحْلِيلِ

21 guide for inserting the proctoscope دَلِيلٌ لإِدْخَالِ المِظْطَارِ الجَوْفِي لِلمُسْتَقِيمِ

22 diathermy unit (short-wave therapy apparatus) وَحْدَةٌ إِيقَادِ الحَرارةِ

23 radiator جِهَانُ الإِشْطَاعِ

24 inhaling apparatus (inhalator) جِهَانُ الاسْتِشْطَاقِ

25 basin (for sputum) حَوْضٌ (لِلصَّماقِ)

26-31 ergometry القياسات

26 bicycle ergometer عَجَلَة لِقِيَاسِ النُّبْضِ وَالتَّنْفُسِ وَرَسْمِ القَلْبِ شاشَة لِلعَرْضِ البَصْرِي لِرَسْمِ القَلْبِ الكَهْرَبائي وَمَعْدَلِ النُّبْضِ وَالتَّنْفُسِ عِنْدَ القِيَامِ بِمَجْهُودٍ

27 monitor (for visual display of the ECG and of pulse and respiratory rates when performing work) رَسَامُ القَلْبِ الكَهْرَبائي

28 ECG (electrocardiograph) الكترودات ماصَة

29 suction electrodes الكترودات شَرِيْبِيَة لِلأَطْرَافِ

30 strap-on electrodes for the limbs مِقْيَاسُ النُّبْضِ

31 spirometer (for measuring respiratory functions) قِيَاسُ صَنْطِ الدَّمِ

32 measuring blood pressure جِهَانٌ قِيَاسِ صَنْطِ الدَّمِ

33 sphygmomanometer كَفَّةٌ قِفاخِيَة

34 inflatable cuff سَمَاعَة طِبِيَة

35 stethoscope وَحْدَةٌ مَعَالِجَة بِالميكرويف

36 microwave treatment unit وَحْدَةٌ المَعَالِجَة الفاراديَة

37 faradization unit (for applying low-frequency currents with different pulse shapes) زَرٌّ الضَّيْبِ الدقيق أَيْضاً

38 automatic tuner مَقْعِدٌ صغِيرٌ

39 short-wave therapy جهاز العلاج بالموجات القصيرة

40 timer جهاز توقيت

41-59 laboratory المعمل، المختبر

41 medical laboratory فَيِّ المِمْسَلِ الطَّبِيبِ

42 technician خَامِلُ أَنْبَابِ شعريَة

42 capillary tube stand for blood sedimentation لَتْرَسِيبِ الدَّمِ

43 measuring cylinder اسْتِطْوَانَة قِيَاسِ

44 automatic pipette جِهَانٌ سَمَطُ أَلِي

45 kidney dish طبق مَعْمَلٌ

46 portable ECG machine for emergency use رَسَامُ قَلْبٍ كَهْرَبائي نَقَالِي لِلاستخدام في الطوارئ

47 automatic pipetting device جِهَانُ السَمَطِ الألي

48 constant temperature حمام ماء ثابت الحرارة

49 tap with water jet حَقِيْبَة/صَبُورٌ ذُو مِمْصَة نَفَاثَة

50 staining dish (for staining blood smears, sediments, and other smears) طَبَقٌ تلوين، طَبَقٌ صَنِيعٌ

51 binocular research microscope ميكروسكوب فَحْصِ ذُو عَيْنَيْتَيْنِ

52 pipette stand for photometry حَامِلُ مِمْصَاتِ لِلْقِيَاسِ الضوئي

53 computer and analyser for photometry حاسِبٌ ألي وَجِهَانٌ لِتَحْلِيلِ القِيَاسِ الضوئي

54 photometer جِهَانُ القِيَاسِ الضوئي

55 potentiometric recorder مَسْجِلٌ قِيَاسِ فَرْقِ الجِهدِ

56 transforming section قِسْمُ التَحْوِيلِ

57 laboratory apparatus (laboratory equipment) مَعْدَاتٌ مَعْمَلِيَة

58 urine sediment chart رَسْمٌ تخطيطي لِترسيب البول

59 centrifuge مِمْصَخَة، فَرَاة بِالطَرْدِ المركزي

24 Dentist طَبِيبُ الأَسْنَانِ

1 dentist (dental surgeon) طَبِيبُ الأَسْنَانِ (جِراحُ الأَسْنَانِ)

2 patient مَرِيضٌ

3 dentist's chair مَقْعِدُ طَبِيبِ الأَسْنَانِ

4 dental instruments أدوات طَبِيبِ الأَسْنَانِ

5 instrument tray صِنِيَّةٌ أدوات

6 drills with different handpieces مِثاقِبٌ/مِخافِرٌ ذَاتُ مَقَابِضِ مِخْتَلِفَة

7 medicine case حَقِيْبَة طِبِيَة

8 storage unit (for dental instruments) وَحْدَةٌ تَخْزِينِ أدوات طَبِيبِ الأَسْنَانِ

9 assistant's unit وَحْدَةٌ المِساعدِ/المِساعدة

10 multi-purpose syringe مِخْطَنٌ مُتَعَدِّدُ الأَغْرَاضِ (for cold and warm water, spray, or air)

11 suction apparatus جِهَانٌ ماصٌ

12 basin حَوْضٌ

13 water glass, filled automatically كُوبٌ ماءٌ يَمْلَأُ أَيْضاً

14 stool مَقْعِدٌ صغِيرٌ

15 washbasin	حوض غسل
16 instrument cabinet	خزانة/صوان الأدوات
17 drawer for drills	دُرَج المَئَاتِب
18 dentist's assistant	مُساعدَة طبيب الأسنان
19 dentist's lamp	مِصباح وَحْدَة الأسنان
20 ceiling light	ضوء مَعلق بالسقف
21 X-ray apparatus for panoramic pictures	جهاز الأشعة السينية لالتقاط صور بانورامية
22 X-ray generator	مُولد الأشعة السينية
23 microwave treatment unit, a radiation unit	وحدة المعالجة بالميكرويف، وحدة إشعاع
24 seat	مقعد
25 denture (set of false teeth)	طاقم أسنان
26 bridge (dental bridge)	كوبري، جسر
27 prepared stump of the tooth	جذر معدّ لتثبيت كوبري
28 crown (kinds: gold crown, jacket crown)	تاج (نوعان تاج ذهب، طُرْبُوش)
29 porcelain tooth (porcelain pontic)	سن من مادة البورسلين
30 filling	حشوة
31 post crown	تاج ذو وَتَد
32 facing	سطح، واجهة
33 diaphragm	حاجز
34 post	وَتَد تثبيت التاج
35 carborundum disc (disk)	قرص من الكربورندوم
36 grinding wheel	عجلة السحل
37 burs	سنايل (جمع سنيلة)
38 flame-shaped finishing bur	سنيلة إنهاء على شكل لهب
39 fissure burs	سنايل شاقبة
40 diamond point	طرف ماسي
41 mouth mirror	مرآة الفم
42 mouth lamp	مصباح الفم
43 cautery	مخضعة الكي
44 platinum-iridium electrode	الكترود بلايني
45 tooth scalars	مقاشط، مقاليح، أدوات تنظيف الأسنان
46 probe	مستبار، مجس
47 extraction forceps	كماشة خلع الأسنان
48 tooth-root elevator	مرفع جذر السن
49 bone chisel	مخّنت/إزميل العظم
50 spatula	ملوقة (أداة المرّج)
51 mixer for filling material	خلّاط مادة الحشو
52 synchronous timer	جهاز توقيت تزامني
53 hypodermic syringe for injection of local anaesthetic	مِحقَن المُخدّر المُوضعي
54 hypodermic needle	إبرة للحقن تحت الجلد
55 matrix holder	حامل المِسندَة
56 impression tray	طابعة (وعاء الطابع)
57 spirit lamp	لمبة كحولية

1-9 control room

1 central control unit for monitoring heart rhythm (cardiac rhythm) and blood pressure	غرفة التحكم وحدة التحكم المركزية لتنظيم ضربات القلب وضغط الدم
2 electrocardiogram monitor (ECG monitor)	شاشة رسّام القلب الكهربي
3 recorder	مسجل
4 recording paper	ورق تسجيل
5 patient's card	بطاقة مريض
6 indicator lights (with call buttons for each patient)	أضواء إرشادية لاستدعاء المريض
7 spatula	ملوقة (أداة المرّج البودرة والمحاليل)
8 window (observation window, glass partition)	نافذة زجاجية للملاحظة
9 blind	ستارة حاجية للضوء
10 bed (hospital bed)	سرير مستنقي
11 stand for infusion apparatus	حامل جهاز المحاليل
12 infusion bottle	زجاجة/قنبلة محاليل
13 tube for intravenous drips	خرطوم تقطيط المحاليل الوريدية
14 infusion device for water-soluble medicaments	جهاز محاليل الأدوية القابلة للذوبان في الماء
15 sphygmomanometer	جهاز قياس ضغط الدم
16 cuff	كفة
17 inflating bulb	مفتاح كفة جهاز الضغط
18 mercury manometer	مانومتر زئبقي
19 bed monitor	شاشة سرير المستشفى
20 connecting lead to the central control unit	كبل التوصيل بوحدة التحكم المركزية
21 electrocardiogram monitor (ECG monitor)	شاشة رسّام القلب الكهربي
22 manometer for the oxygen supply	مقياس إمداد الأكسجين
23 wall connection for oxygen treatment	وصلة في الحائط لتصديد جهاز الأكسجين
24 mobile monitoring unit	وحدة شاشة عرض متنقلة
25 electrode lead to the short-term pacemaker	كبل توصيل الكترود بمنظّم ضربات القلب قصير الأجل
26 electrodes for shock treatment	الكترودات للمعالجة الصدمية
27 ECG recording unit	وحدة تسجيل رسّام القلب الكهربي
28 electrocardiogram monitor (ECG monitor)	شاشة رسّام القلب الكهربي
29 control switches and knobs (controls) for adjusting the monitor	مفاتيح التحكم لضبط وتعديل الشاشة
30 control buttons for the pacemaker unit	مفاتيح التحكم في وحدة منظّم ضربات القلب
31 pacemaker (cardiac pacemaker)	منظّم ضربات القلب

المستشفى (1)
وحدة العناية المركزة

32 mercury battery	بطارية زئبقية
33 programmed impulse generator	مولد نبضات مبرمج
34 electrode exit point	موضع خروج كبل الكترود
35 electrode	الكترود
36 implantation of the pacemaker	زرع منظّم ضربات القلب
37 internal cardiac pacemaker (internal pacemaker, pacemaker)	منظّم ضربات قلب داخلي
38 electrode inserted through the vein	الكترود داخل الوريد
39 cardiac silhouette on the X-ray	صورة القلب على فيلم الأشعة السينية
40 pacemaker control unit	وحدة التحكم في منظّم ضربات القلب
41 electrocardiograph (ECG recorder)	رسّام قلب كهربي
42 automatic impulse meter	مقياس نبض آلي
43 ECG lead to the patient	كبل توصيل رسّام القلب الكهربي بالمريض
44 monitor unit for visual monitoring of the pacemaker impulses	وحدة الشاشة الخاصة بالمراقبة البصرية لنبضات منظّم ضربات القلب
45 long-term ECG analyser	محلّل رسّم القلب الكهربي الممتد
46 magnetic tape for recording the ECG impulses during analysis	شريط مغناطيسي لتسجيل نبضات رسّام القلب أثناء التحليل
47 ECG monitor	شاشة رسّام القلب الكهربي
48 automatic analysis on paper of the ECG rhythm	تحليل آلي على الورق لنظم رسّام القلب الكهربي
49 control knob for the ECG amplitude	ذراع التحكم في سعة رسّام القلب الكهربي
50 program selector switches for the ECG analysis	مفاتيح اختيار برامج تحليل رسّام القلب الكهربي
51 charger for the pacemaker batteries	جهاز شحن بطاريات منظّم ضربات القلب
52 battery tester	جهاز اختبار البطاريات
53 pressure gauge (Am. gage) for the right cardiac catheter	مقياس الضغط الخاص بقطعة القلب
54 trace monitor	شاشة المتابعة
55 pressure indicator	مؤشر الضغط
56 connecting lead to the paper recorder	كبل توصيل إلى جهاز التسجيل على الورق
57 paper recorder for pressure traces	جهاز التسجيل على الورق الخاص بتتبع الضغط

26 Hospital II
1-54 surgical unit
1-33 operating theatre (Am. theater)

1 anaesthesia and breathing apparatus (respiratory machine)	جهاز التخدير والتنفس
2 inhalers (inhaling tubes)	خرطوم الاستنشاق
3 flowmeter for nitrous oxide	مقياس تدفق أكسيد النيتروجين
4 oxygen flow meter	مقياس تدفق الأكسجين
5 pedestal operating table	سرير عمليات يتم خفضه ورفعُه ببدالة سفلية
6 table pedestal	بدالة السرير
7 control device (control unit)	وحدة التحكم
8 adjustable top of the operating table	سطح سرير العمليات القابل للتعديل
9 stand for intravenous drips	حامل المحاليل الوريدية
10 swivel-mounted shadow-free operating lamp	نظام إنارة للعمليات الجراحية عديم الظلال مُكَلّف على محور دوار
11 individual lamp	مصباح مفرد
12 handle	ذراع، مقبض
13 swivel arm	ذراع تدوير/ دوار
14 mobile fluoroscope	منظار فلورية نقالي
15 monitor of the image converter	شاشة عرض مُحوّل الصورة
16 monitor [back]	شاشة عرض (من الخلف)
17 tube	خرطوم، أنبوب
18 image converter	محوّل الصورة
19 C-shaped frame	إطار قوسي
20 control panel for the air-conditioning	وحدة التحكم في مكيف الهواء
21 surgical suture material	خيط جراحة
22 mobile waste tray	سلة مهملات متحركة
23 containers for unsterile (unsterilized) pads	حاوية للحشيات غير المعقمة
24 anaesthesia and respiratory apparatus	جهاز التخدير والتنفس
25 respirator	جهاز تنفس صناعي
26 fluothane container (halothane container)	أسطوانة الهالوثان
27 ventilation control knob	مقبض التحكم في التهوية
28 indicator with pointer for respiratory volume	شاشة ومؤشر حجم التنفس
29 stand with inhalers (inhaling tubes) and pressure gauges (Am. gages)	حامل مقاييس خراطيم الاستنشاق والضغط
30 catheter holder	حامل القططرة
31 catheter in sterile packing	قططرة في غلاف معقم
32 sphygmograph	مخطّط النبض
33 monitor	شاشة عرض
34-54 preparation and sterilization room	غرفة الإعداد والتعقيم
34 dressing material	ضمادات
35 small sterilizer	جهاز تعقيم صغير
36 carriage of the	عربة سرير العمليات

المستشفى (2)
وحدة الجراحة
غرفة العمليات

operating table	طاولة أدوات نقالة
37 mobile instrument table	طاولة أدوات نقالة
38 sterile cloth	نسيج مُعقم
39 instrument tray	صينية الأدوات
40-53 surgical instruments	الأدوات الجراحية
40 olive-pointed (bulb-headed) probe	مجسّ ذو رأس متفخف
41 hollow probe	مجسّ أجوف
42 curved scissors	مقصّ منحنى الطرف
43 scalpel (surgical knife)	سِكْرَط
44 ligature-holding forceps	جفت منسك الأربطة
45 sequestrom forceps	جفت الوشيط
46 jaw	فكّ
47 drainage tube	أنبوب تصريف
48 surgeon's tourniquet	عاصبة التورنيكيت
49 artery forceps	جفت شرايين
50 blunt hook	خُطاف
51 bone nippers (bone-cutting forceps)	جفت العظام
52 scoop (curette) for erosion (curette)	مِكتنفة، مِكتنفة
53 obstetrical forceps	جفت توليد
54 roll of plaster	بكرة شريط لاصق/ بلاستر
27 Hospital III	المستشفى (3)
1-35 X-ray unit	وحدة الأشعة السينية
1 X-ray examination table	طاولة الفحص بالأشعة السينية
2 support for X-ray cassettes	حامل كاسيتات أفلام الأشعة السينية
3 height adjustment of the central beam for lateral views	ضبط ارتفاع العمود المركزي من أجل الروية العرضية
4 compress for pyelography and cholecystography	مضغظ تصوير حوض الكلى والحالب وتصوير المرارة
5 instrument basin	جفنة الأدوات
6 X-ray apparatus for pyelograms	جهاز الأشعة السينية الخاص بتصوير حوض الكلى والحالب
7 X-ray tube	أنبوب الأشعة السينية
8 telescopic X-ray support	حامل أشعة سينية تلسكوبي
9 central X-ray control unit	وحدة التحكم المركزية للأشعة السينية
10 control panel (control desk)	لوحة التحكم
11 radiographer (X-ray technician)	فني أشعة
12 window to the angiography room	نافذة تطل على غرفة التصوير الوعائي
13 oxymeter	مقياس الأكسجين
14 pyelogram cassettes	كاسيتات تصوير حوض الكلى والحالب
15 contrast medium injector	حاقن وسط التباين
16 X-ray image intensifier	مكثف صورة الأشعة السينية
17 C-shaped frame	إطار قوسي

18 X-ray head with X-ray tube	رأس توليد الأشعة السينية
19 image converter with converter tube	المزود بأنبوب الأشعة
20 film camera	محول الصورة المزود بصمام المحول
21 foot switch	آلة تصوير أفلام الأشعة
22 mobile mounting	مفتاح سطحي
23 monitor	حامل متحرك
24 swivel-mounted monitor support	شاشة
25 operating lamp	حامل شاشة مثبت على محور دوراني
26 angiographic examination table	مصباح
27 pillow	سرير التصوير الوعائي
28 eight-channel recorder	وسادة
29 recording paper	مسجل ذو ثماني قنوات ورق تسجيل
30 catheter gauge (Am. gage) unit for catheterization of the heart	ورق تسجيل وحدة جهاز القطرة الخاصة بقسطرة القلب
31 six-channel monitor for pressure graphs and ECG	شاشة ذات ست قنوات لمخطط الضغط ورسم القلب الكهربائي
32 slide-in units of the pressure transducer	وحدات محول طاقة الضغط
33 paper recorder unit with developer for photographic recording	وحدة التسجيل على الورق الخاصة بالتسجيل الفوتوغرافي وبها وحدة تجميع
34 recording paper	ورق تسجيل
35 timer	جهاز توقيت
36-50 spirometry	قياس التنفس
36 spirometry for pulmonary function tests	تخطيط التنفس لاختبارات كفاءة وظيفية للرئتين
37 breathing tube	أنبوب التنفس
38 mouthpiece	بمس (الجزء الذي يوضع بالحلم)
39 soda-lime absorber	مادة ماصة من جبر الصودا
40 recording paper	ورق تسجيل
41 control knobs for gas supply	مفاتيح التحكم في معدل إمداد الغاز
42 O ₂ stabilizer	موازن الأكسجين
43 throttle valve	صمام خائق
44 absorber attachment	وصلة جهاز الامتصاص
45 oxygen cylinder	أسطوانة الأكسجين
46 water supply	مصدر إمداد الماء
47 tube support	حامل الأنبوب
48 mask	قناع، كمامة
49 CO ₂ consumption meter	مقياس استهلاك ك 2أ
50 stool for the patient	(ثاني أكسيد الكربون) مقعد المريض
28 Infant Care and Layette	العناية بالطفل ولوازم الأطفال
1 collapsible cot	سرير طفل قابل للطي
2 bouncing cradle	مهد هزاز
3 baby bath	حمام أطفال
4 changing top	طاولة تغيير الملابس
5 baby (new-born baby)	طفل (رضيع)
6 mother	أم

7 hairbrush	فرشاة شعر
8 comb	مشط
9 hand towel	مشفة يد، فوطة
10 toy duck	لعبة على شكل بطة
11 changing unit	صوان التغييرات
12 teething ring	عضاضة، حلقة التسنين
13 cream jar	وعاء/ قنينة كريم
14 box of baby powder	علبة بودرة أطفال
15 dummy	ذمية
16 ball	كرة
17 sleeping bag	كيس نوم
18 layette box	صندوق لوازم الطفل المولود
19 feeding bottle	رضاعة، زجاجة الإرضاع
20 teat	حلقة
21 bottle warmer	صندوق تدفئة الرضاعة
22 rubber baby pants for disposable nappies (Am. diapers)	حفاضات الطفل تستعمل مرة واحدة فقط
23 vest	صدرية
24 leggings	الطماق
25 baby's jacket	سرة طفل
26 hood	قلنسوة غطاء للرأس والرقبة معاً
27 baby's cup	كوب أطفال
28 baby's plate, a stay-warm plate	طبق أطفال، طبق يحفظ الطعام دافئاً
29 thermometer	ترمومتر
30 bassinet, ■ wicker pram	مهد شبيه بالسلة
31 set of bassinet covers	طاقم أغشية المهد
32 canopy	قبة، غطاء شفاف
33 baby's high chair, a folding chair	كرسي أطفال مرتفع، كرسي قابل للطي
34 pram (baby-carriage) [with windows]	عربة أطفال [ذات نوافذ]
35 folding hood	غطاء قابل للطي
36 window	نافذة
37 pushchair (Am. stroller)	عربة أطفال، كرسي متحرك للأطفال
38 foot-muff (Am. foot-bag)	موقية (تدفئة) القدمين
39 play pen	خجيرة اللعب
40 floor of the play pen	أرضية خجيرة اللعب
41 building blocks (building bricks)	مكعبات بناء
42 small child	طفل صغير
43 bib	صدرية الطفل (توضع تحت ذقنه أثناء الطعام)
44 rattle (baby's rattle)	خشخيشة
45 booties	حذاء قصير، جورب صوف
46 teddy bear	للأطفال
47 potty (baby's pot)	دبّ لعبة
48 carrycot	نوعية للأطفال
49 window	مهد يحمل يدويًا
50 handles	نافذة
	مقبضان
29 Children's Clothes	ملابس الأطفال
1-12 baby clothes	ملابس الطفل الرضيع

1 pram suit	بذلة خروج
2 hood	قلنسوة (تغطي الرأس والرقبة معاً)
3 pram jacket (matinée coat)	سرة ماتينية (مخطف صوفي)
4 pompon (bobble)	بمبونة، شرابية
5 booties	حذاء صوفي للطفل
6 sleeveless vest	صدرية بدون أكمام
7 envelope-neck vest	صدرية ذات فتحة رقبة طرفية
8 wrapover vest	صدرية تشد خارجياً
9 baby's jacket	سرة طفل
10 rubber baby pants	حفاض
11 playsuit	لباس اللعب
12 two-piece suit	بذلة مكونة من قطعتين
13-30 infants' wear	ملابس أطفال
13 child's sundress, a pinafore dress	مئزر للأطفال من غير أكمام
14 frilled shoulder strap	حزام كتف مكشكشة
15 Shirred top	جزء علوي مدرز
16 sun hat	قبعة واقية من الشمس
17 one-piece jersey suit	جرس صوفي قطعة واحدة
18 front zip (Am. zipper)	سوستة أمامية
19 catsuit (playsuit)	لباس اللعب
20 motif (appliqué)	زخارف ألكة
21 romper	سرّوال قصير للعب
22 playsuit (romper suit)	لباس اللعب
23 overall (sleeper and strampler)	مئزر، كفول
24 dressing gown (bath robe)	رُوب حمام (برنس)
25 children's shorts	بنطلون قصير للأطفال (شورت)
26 braces (Am. suspenders)	حزامان
27 children's T-shirt	تي شيرت للأطفال، كترزة
28 jersey dress (knitted dress)	ثانئة
29 embroidery	فستان جرسية (فستان تريكو)
30 children's ankle socks	تطريز
31-47 school children's wear	جورب قصير للأطفال
31 raincoat	ملابس المدرسة للأطفال
32 leather shorts (lederhosen)	معطف واق من المطر
33 staghorn button	بنطلون جلدي قصير
34 braces (Am. suspenders)	زر
35 flap	حزامان
36 girl's dirndl	قلابة
37 cross lacing	درندل بناتي
38 snow suit (quilted suit)	رباط (شريط) مقاطع
39 quilt stitching (quilting)	بذلة مبينة
40 dungarees (bib and brace)	عُرزة تضريبية
41 bib skirt (bib top pinafore)	دغري سرّوال من قماش خشن
42 tights	تنورة صدرية
	جورب طويل ضيق يغطي

بذلة خروج	1 pram suit
قلنسوة (تغطي الرأس والرقبة معاً)	2 hood
سرة ماتينية (مخطف صوفي)	3 pram jacket (matinée coat)
بمبونة، شرابية	4 pompon (bobble)
حذاء صوفي للطفل	5 booties
صدرية بدون أكمام	6 sleeveless vest
صدرية ذات فتحة رقبة طرفية	7 envelope-neck vest
صدرية تشد خارجياً	8 wrapover vest
سرة طفل	9 baby's jacket
حفاض	10 rubber baby pants
لباس اللعب	11 playsuit
بذلة مكونة من قطعتين	12 two-piece suit
ملابس أطفال	13-30 infants' wear
مئزر للأطفال من غير أكمام	13 child's sundress, a pinafore dress
حزام كتف مكشكشة	14 frilled shoulder strap
جزء علوي مدرز	15 Shirred top
قبعة واقية من الشمس	16 sun hat
جرس صوفي قطعة واحدة	17 one-piece jersey suit
سوستة أمامية	18 front zip (Am. zipper)
لباس اللعب	19 catsuit (playsuit)
زخارف ألكة	20 motif (appliqué)
سرّوال قصير للعب	21 romper
لباس اللعب	22 playsuit (romper suit)
مئزر، كفول	23 overall (sleeper and strampler)
رُوب حمام (برنس)	24 dressing gown (bath robe)
بنطلون قصير للأطفال (شورت)	25 children's shorts
حزامان	26 braces (Am. suspenders)
تي شيرت للأطفال، كترزة	27 children's T-shirt
ثانئة	28 jersey dress (knitted dress)
فستان جرسية (فستان تريكو)	29 embroidery
تطريز	30 children's ankle socks
جورب قصير للأطفال	31-47 school children's wear
ملابس المدرسة للأطفال	
معطف واق من المطر	31 raincoat
بنطلون جلدي قصير	32 leather shorts (lederhosen)
زر	33 staghorn button
حزامان	34 braces (Am. suspenders)
قلابة	35 flap
درندل بناتي	36 girl's dirndl
رباط (شريط) مقاطع	37 cross lacing
بذلة مبينة	38 snow suit (quilted suit)
عُرزة تضريبية	39 quilt stitching (quilting)
دغري سرّوال من قماش خشن	40 dungarees (bib and brace)
تنورة صدرية	41 bib skirt (bib top pinafore)
جورب طويل ضيق يغطي	42 tights

(شورت حریمی)

ثنية الشورت
كمر الخصر

جاكيت متفتح للسيدات
حاشية/سترة مطاطي للترزين

بنطال برمودا قصير
غرز سرجية، سراجة

ياقة مكشكشة

عقدة

كولوت

طاقم توبنز

سترة ضيقة

صدرية، سويتز

بنطال صيفي (خفيف)

بدلة قطعة واحدة بنوسنة

أمامية

طية كم لأعلى

سوستة، سنخاب

جيب خارجي

إيشبار، وشاح

بدلة من الدنيم (بدلة جينز)

جاكيت البدلة الدنيم

بنطال جينز

بلوزة خارجية

كم متشي لأعلى

حزام مطاط (سترتش)

صدرية مكشوفة الظهر

صدرية تريكو ترتدي فوق

الملايس

وسط يحكم بشد الرباط

بلوزة تريكو ذات كم قصير

رقبة على شكل V

ياقة قلابية

حاشية/سترة مشغول

بالصنارة (تريكو)

شال

ملايس الداخليّة،

ملايس اللّوم

الملايس الداخليّة

النسائيّة

صدرية للترزين (سوتيان)

سرّوال داخلي يمشد

كورسيه بسروال داخلي

سوتيان كاش

مشد، إزار مطاطي

مشد الجوارب

قميص داخلي قصير

سروال حريمي داخلي

قصير

جوارب حريمي طويل حتى

الركبة

سروال داخلي طويل

سرّوال طويل

سرّوال طويل

جوارب طويل ضيق يغطي

المئك، السّور)

معطف شتوي

كفة من الفرو

ياقة من الفرو

معطف شبيه بالكاب

كاب

زرّ عديّ

تتورة فضفاضة

معطف شبيه بالعباءة

قلنسوة

ملايس السيّدات (2)

(الملايس الضيقية)

تايبز

جاكيت

تتورة

جيب داخلي

غرز تطريزيّة

طاقم من قستان و جاكيت

شرط ترزين

قستان بدون أكمام

قستان صيفي

حزام

قستان من قطعتين

إيزيم الجزام

تتورة تلف حول ترتدي فوق

سويت رفيع

أزرار فوق الكتف

كم خفّاش

توب قوقي

كتف كيمونو

حزام يربط في شكل عقدة

معطف صيفي

قلنسوة قابلة للفصل من

التوب

بلوزة صيفيّة

طية صدر البلوزة

تتورة

طية أمامية

دردنل (قستان الدردنل)

كم متقوش

عقد الدردنل

بلوزة الدردنل

صدر التوب

مربطة الدردنل

دانشيا قطنية (تدريز)

مربطة مكشكشة

كشكشة

أوفرول "سموك"

قستان بيت

جاكيت بوبلين

تي شيرت

بنطال قصير للسيدات

sable)

61 winter coat (cloth coat)

62 fur cuff (fur-trimmed cuff)

63 fur collar (fur-trimmed collar)

64 loden coat

65 cape

66 toggle fastenings

67 loden skirt

68 poncho-style coat

69 hood

31 Ladies' Wear II (Summer Wear)

1 skirt suit

2 jacket

3 skirt

4 inset pocket

5 decorative stitching

6 dress and jacket combination

7 piping

8 pinafore dress

9 summer dress

10 belt

11 two-piece dress

12 belt buckle

13 wrapover (wrap-around) skirt

14 pencil silhouette

15 shoulder buttons

16 batwing sleeve

17 overdress

18 kimono yoke

19 tie belt

20 summer coat

21 detachable hood

22 summer blouse

23 lapel

24 skirt

25 front pleat

26 dirndl (dirndl dress)

27 puffed sleeve

28 dirndl neckline

29 dirndl blouse

30 bodice

31 dirndl apron

32 lace trimming (lace), cotton lace

33 frilled apron

34 frill

35 smock overall

36 house frock (house dress)

37 poplin jacket

38 T-shirt

39 ladies' shorts

كَم طَوِيل

صدرية منبطّة

غرزّة تمريزيّة

قلاّمة جلديّة

بنطلون حريمي شتوي

كغرّة مكشّطة ذات رقبة

عالية ضيقة

بدلة تدغري

جيب خارجي (مئبّت

بالخياطة فوق التوب)

جيب أمامي

صدرية التتورة

توب شبيه بالعباءة

قميص

قستان/ توب (شبيه بلباس

الفلانجين)

زرّكشة بالورد

التك بلوزة أو سترة طويلة

كفة/أسورة كم مضلّعة

تصميم تمريزي

تتورة مكسرة

توب/قستان تريكو من

قطعتين

خط الرقبة

طية (في الكم) لأعلى

كم كيمونو (بدون كلف)

تصميم تدريّز

سترة متينة للحم

زرّكشة كليلية

بلوزة

غرزة زر أنشوطية

تطريز

ياقة عالية

بنطلون قوقازي (موديل)

توب من قطعيتين (قميص

وتتورة طويلة)

عقدة أنشوطية

تخريج قماش يخاط على

التوب للترزين

فتحة أسورة الكم

فتحة جانبيّة

بلوزة فضفاضة (مليرد) غير

محاكة من الجانبين

تتورة ذات طية مقنونة

جودي، طية/كسرة إلى

الداخل

قستان مسائي

كم يلبسه جرسى الشكل

بلوزة سهرة

تتورة سهرة

بدلة حريمي فضفاضة

جاكيت شمواه

قلاّمة من الفرو

معطف من الفرو (الأنواع

الحصّل الفارسي، الفركول،

15 long sleeve

16 quilted waistcoat

17 quilt stitching (quilting)

18 leather trimming

19 winter slacks

20 striped polo jumper

21 boiler suit (dungarees, bib and brace)

22 patch pocket

23 front pocket

24 bib

25 wrapover dress (wrap-around dress)

26 shirt

27 peasant-style dress

28 floral braid

29 tunic (tunic top)

30 ribbed cuff

31 quilted design

32 pleated skirt

33 two-piece knitted dress

34 boat neck, a neckline

35 turn-up

36 kimono sleeve

37 knitted design

38 lumber-jacket

39 cable pattern

40 shirt-blouse

41 loop fastening

42 embroidery

43 stand-up collar

44 cossack trousers

45 two-piece combination (shirt top and long skirt)

46 tie (bow)

47 decorative facing

48 cuff slit

49 side slit

50 tabard

51 inverted pleat skirt

52 godet

53 evening gown

54 pleated bell sleeve

55 party blouse

56 party skirt

57 trouser suit (slack suit)

58 suede jacket

59 fur trimming

60 fur coat (kinds: Persian lamb, broadtail, mink,

نصف الجسم

سويتز، كغرّة

سترة مكشّطة

طماق

تتورة (جوب، جونية)

بلوزة تريكو للأطفال

ملايس المراهبين

بلوزة خارجيّة

بنطلون

بدلة (الفتيات) مكونة من

سترة وتتورة

سترة، جاكيت

تتورة (جوب، جونية)

جوزب يصل إلى الركبة

معطف بناتي

حزام يربط في شكل عقدة

حقيقية يد بناتي

قبعة صوفيّة

بلوزة بناتي

كولوت (تتورة محيطية في

شكل بنطلون)

بنطلون أولادي

قميص أولادي

معطف قصير ذو قلنسوة

جيب داخلي (مئبّت بالخياطة

داخل التوب)

رباط إحكام القلنسوة

أسورة كم محيطية/مشغولة

معطف قصير مزود بقلنسوة

رباط إحكام المعطف عند

الخصر

جيب خارجي (مئبّت

13 slip	نصف الجسم السفلي قميص داخلي طويل	7 dinner dress, an evening suit	بدلة سهرة
14 waist slip	جيبونة	8 silk lapel	ياقة حرير، صدر حرير
15 bikini briefs	سروال بكيني	9 breast pocket	جيب الصدر
16-21 ladies' nightwear	ملابس النوم النسائية	10 dress handkerchief	مذيبل بدلة
16 nightdress (nightgown, nightie)	قميص نوم	11 bow-tie	باييون
17 pyjamas (Am. pajamas)	بيجاما	12 side pocket	جيب جانبي
18 pyjama top	جاكت البيجاما	13 tailcoat (tails), evening dress	بدلة ريدجوت، بدلة سهرة
19 pyjama trousers	بنطال البيجاما	14 coat-tail	ذيل الجاكت
20 housecoat	روب منزلي	15 white waistcoat (vest)	صديري ابيض
21 vest and shorts set [for leisure wear and as nightwear]	طاقم فائلة وشورت للتره ولباس ليالي]	16 white bow-tie	باييون ابيض
22-29 men's underwear (men's underclothes)	الملابس الداخلية الرجالية	17 casual suit	بدلة كاجوال
22 string vest	فائلة غربيالية	18 pocket flap	قلابة/ غطاء الجيب
23 string briefs	سروال غربيالي	19 front yoke	سفرة امامية، كخر
24 front panel	بطانة السروال الامامية	20 denim suit	بدلة دنيم (بدلة جينز)
25 sleeveless vest	فائلة بصحلات (بدون اكمام)	21 denim jacket	جاكت دنيم
26 briefs	سروال داخلي قصير	22 jeans (denims)	بنطال جينز (دنيم)
27 trunks	سروال شورت	23 waistband	كخر الخصر
28 short-sleeved vest	فائلة داخلية باكمام قصيرة	24 beach suit	لباس البحر
29 long Johns	سروال طويل	25 shorts	شورت (بنطال قصير)
30 braces (Am. suspenders)	حمالة	26 short-sleeved jacket	جاكت بكتم قصير
31 braces clip	مشبك حمالة	27 tracksuit	بدلة/لباس التدريب
32-34 men's socks	الجوارب الرجالي	28 tracksuit top with zip	سفرة لباس تدريب مزودة بسوستة
32 knee-length sock	جورب طويل حتى الركبة	29 tracksuit bottoms	بنطال لباس التدريب
33 elasticated top	استك (الطرف المطاطي)	30 cardigan	جاكت/سفرة صوف
34 long sock	الجورب	31 knitted collar	ياقة مشغولة بالمشارة
35-37 men's nightwear	ملابس النوم الرجالية	32 men's short-sleeved pullover (men's short-sleeved sweater)	بلوفر باكمام قصيرة
35 dressing gown	روب نوم قصير	33 short-sleeved shirt	قميص بكتم قصير
36 pyjamas (Am. pajamas)	بيجاما	34 shirt button	زر قميص
37 nightshirt	قميص للنوم	35 turn-up	طية خارجية
38-47 men's shirts	قمصان رجالي	36 knitted shirt	فائلة خارجية مشغولة بالمشارة
38 casual shirt	قميص خارجي (كاجوال)	37 casual shirt	قميص كاجوال
39 belt	حزام	38 patch pocket	جيب خارجي (محاك على القميص من الخارج)
40 cravat	كرافات	39 casual jacket	جاكت كاجوال
41 tie	رباط العنق	40 knee-breeches	بنطال قصير (الركوب الخيل)
42 knot	عقدة	41 knee strap	شريط/رباط الركبة
43 dress shirt	قميص بدلة	42 knee-length sock	جورب طويل حتى الركبة
44 frill (frill front)	كثكثفة	43 leather jacket	جاكت جلدي
45 cuff	أسورة القميص	44 bib and brace overalls	أوفرول مفتوح
46 cuff link	زر معدني لكم القميص	45 adjustable braces (Am. suspenders)	جيب أمامي
47 bow-tie	باييون، رابطة عنق أنشوطية	46 front pocket	جيب بنطال
33 Men's Wear	ملابس الرجال	47 trouser pocket	جيب بنطال
1-67 men's fashion	الأزياء الرجالي	48 fly	لسان تغطية السوستة
1 single-breasted suit, a men's suit	بدلة رجالي	49 rule pocket	جيب جانبي صغير لوضع المسطرة وخلافة
2 jacket	جاكت، سفرة	50 check shirt	قميص كاروه (مربعات)
3 suit trousers	بنطال البدلة	51 men's pullover	بلوفر رجالي
4 waistcoat (vest)	صديري	52 heavy pullover	بلوفر ثقيل
5 lapel	ياقة/طية صدر الجاكت	53 knitted waistcoat (vest)	صديري مشغول بالمشارة
6 trouser leg with crease	رجل بنطال ذات ثنية امامية	54 blazer	جاكت بليزر (دو صقن من الأزرار)
		55 jacket button	زر جاكيت

56 overall	أوفرول (الباطو)	short beard bristles	سؤالف، سبيلات
57 trenchcoat	معطف واق من المطر	24 side-whiskers (sideboards, sideburns)	حلاقة نامعة
58 coat collar	ياقة المعطف	25 clean shave	شريحة أفريقي (كنيش) للرجال والنساء
59 coat belt	حزام المعطف	26 Afro look (for men and women)	شريحات الشعر النسائية
60 poplin coat	معطف بولين	27-38 ladies' hairstyles (coiffures, women's and girls' hairstyles)	ذيل حصان (كودو شفال) شعر مشط للطف
61 coat pocket	جيب المعطف	27 ponytail	كعكة (شيبونون) صغيرتان
62 fly front	لسان تغطية الأزرار (أو السوستة)	28 swept-back hair (swept-up hair, pinned-up hair)	شريحة الإكليل (Gretchen style)
63 car coat	معطف قصير	29 bun (chignon)	إكليل ملفوف
64 coat button	زر المعطف	30 plaits (punches)	شعر معقوص/مجمع
65 scarf	وشاح	31 chaplet hairstyle (Gretchen style)	قصة الشعر القصير
66 cloth coat	معطف طويل	32 chaplet (coiled plaits)	شريحة شعر نسائية يرسل فيها الشعر حتى الكتفين ويلتف إلى الداخل
67 glove	قفاز	33 curled hair	شعر مصفف فوق الجبين
34 Hairstyles and Beards	قصات الشعر وأشكال اللحية	34 shingle (shingled hair, bobbed hair)	شريحة الككتين
1-25 men's beards and hairstyles (haircuts)	اللحيات وقصات الشعر الرجالية	35 pageboy style	ضفيرة ملفوفة
1 long hair worn loose	شعر طويل منتزيس	36 fringe (Am. bangs)	أغطية الرأس
2 allonge periwig (full-bottomed wig), a wig; shorter and smoother: bob wig, toupet	شعر منتعار (باروكة) في شكل عقمصات	37 earphones	القبعات والقنصوات النسائية
3 curls	عقمصة، جمعة	38 earphone (coiled plait)	مصنعة قبعات نسائية تصنع قبة
4 bag wig (purse wig)	شعر منتعار (باروكة) على شكل كيس	39 Headgear	قلمشوة
5 pigtail wig	شعر منتعار (باروكة) على شكل ضفيرة في مؤخرة الرأس	1-21 ladies' hats and caps	قالب
6 queue (pigtail)	ضفيرة صغيرة تتدلى من مؤخرة الرأس	1 milliner making a hat	قطع للزينة
7 bow (ribbon)	شريط	2 hood	صومبريرة (موديل مكسيكي)
8 handlebars (handlebar moustache, Am. moustache)	شارب مستقيم	3 block	قبة من المهير والريش
9 centre (Am. center) parting	فرق الشعر بمنتصف الرأس	4 decorative pieces	قبة ذات ألبك مزخرف
10 goatee (goatee beard), chintuft	العنتون: لحية صغيرة منسدبة	5 sombrero	كاب من الكتان (كاب الفروسية)
11 closely-cropped head of hair (crew cut)	شريحة الشعر القصير	6 mohair hat with feathers	قبة مصنوعة من غزل قلتي ثقيل
12 whiskers	سيلة	7 model hat with fancy appliqué	قبة صوفية
13 Vandyke beard (stiletto beard, bodkin beard), with waxed moustache (Am. moustache)	لحية فاندايك (لحية مدببة الطرف) مع شارب منمّص	8 linen cap (jockey cap)	قبة من المهير
14 side parting	فرق جانبي الرأس	9 hat made of thick candlewick yarn	قبة جزئية الشكل مزخرفة بريش
15 full beard (circular beard, round beard)	لحية كاملة/منسدبة	10 woollen (Am. woolen) hat (knitted hat)	قبة رجالية كبيرة مصنوعة من السيزال وشريط مضلع
16 tile beard	لحية مستطيلة	11 mohair hat	قبة إفرنجية من الجوخ الناعم ذات شريط زخرفي
17 shadow	شارب صغير مدبب الطرفين	12 cloche with feathers	قبة من اللباد الناعم
18 head of curly hair	شعر مجمع	13 large men's hat made of sisal with corded ribbon	قبة بنما مزينة بوشاح
19 military moustache (Am. mustache) (English-style moustache)	شارب عسكري (موديل إنجليزي)	14 trilby-style hat with fancy ribbon	قبة من فراء الميك ذات
20 partly bald head	رأس صلعاء جزئياً	15 soft felt hat	
21 bald patch	منطقة صلعاء	16 Panama hat with scarf	
22 bald head	رأس صلعاء	17 peaked mink cap	
23 stubble beard (stubble,	لحية منبّة		

18	mink hat	قبعة مستديرة قبعة من فراء الملك
19	fox hat with leather top	قبعة من فراء الثعلب ذات قمة جلدية
20	mink cap	كاب من فراء الملك
21	slouch hat trimmed with flowers	قبعة من الجوخ ذات حافة عريضة من الزهور
22-40	men's hats and caps	القبعات والقشونات الرجالية
22	tribly hat (tribly)	قبعة إفرنجية من الجوخ الناعم
23	loden hat (Alpine hat)	قبعة اليبينة
24	felt hat with tassels (Tyrolean hat, Tyrolese hat)	قبعة من اللباد ذات شرابة من الخلف
25	corduroy cap	كاب من القטיפ المصنعة
26	woollen (Am. woolen) hat	قبعة صوفية
27	beret	بيريه
28	German sailor's cap (‘Prinz Heinrich’ cap)	كاب البحار الألماني
29	peaked cap (yachting cap)	كاب كابتن بحار
30	sou’wester (south- wester)	قبعة من المشمع لها حافة خلفية عريضة
31	fox cap with earflaps	قبعة من فراء الثعلب مزودة بغطائين للأذنين
32	leather cap with fur flaps	قبعة جلدية ذات قلابات من الفراء
33	musquash cap	قبعة من فراء فأر المسك
34	astrakhan cap, a real or imitation astrakhan cap	كاب من صوف الأستراخان
35	boater	قبعة قش عريضة الحافة
36	(grey, Am. gray, or black) top hat made of silk taffeta; collapsible: crush hat (opera hat, claque)	قبعة رسمية من تفتاه الحرير، قبعة سواد حريرية عالية قابلة للطي
37	sun hat (lightweight hat made of cloth with small patch pocket)	قبعة شمس (من القماش وبها جييب خارجي صغير)
38	wide-brimmed hat	قبعة ذات إفريز ممتع
39	toboggan cap (skiing cap, ski cap)	قبعة التزلج على الجليد
40	workman’s cap	قبعة العمال (للمزارعين وعمال الغابات والجرابين)
36	Jewellery (Am. Jewelry)	المجوهرات
1	set of jewellery (Am. jewelry)	طاقم المجوهرات
2	necklace	عقد، قلادة
3	bracelet	سوار، أسورة
4	ring	خاتم
5	wedding rings	دبلتا/خاتم الزواج
6	wedding ring box	علبة خاتمي الزواج
7	brooch, a pearl brooch	بروش، بروش لؤلؤ
8	pearl	لؤلؤة
9	cultured pearl bracelet	سوار/أسورة من اللؤلؤ

10	clasp, a white gold clasp	الصناعي إبزيم، ميثيق من الذهب الابيض
11	pendant earrings (drop earrings)	حلقة دلالية
12	cultured pearl necklace	عقد من اللؤلؤ الصناعي
13	earrings	حلقة
14	gemstone pendant	حليقة مزودة بالأحجار الكريمة
15	gemstone ring	خاتم به حجر كريم
16	choker (collar, neck- band)	عقد ضيق، كولييه
17	bangle	سوار المصنوع أو خلخال للقدم
18	diamond pin	نبوس ألماس
19	modern-style brooches	بروش (موديل حديث)
20	man’s ring	خاتم رجالي
21	cuff links	دبوسان لأسورة المعصم
22	tiepin	نبوس رباط العنق
23	diamond ring with pearl	خاتم ألماس بلؤلؤة
24	modern-style diamond ring	خاتم ألماس (موديل حديث)
25	gemstone bracelet	سوار مزود بالأحجار الكريمة
26	asymmetrical bangle	سوار/أسورة معصم، خلخال قدم لامتماثل
27	asymmetrical ring	خاتم لامتماثل
28	ivory necklace	عقد عاج
29	ivory rose	وردة عاج
30	ivory brooch	بروش عاج
31	jewel box (jewel case)	صندوق مجوهرات
32	pearl necklace	عقد لؤلؤ
33	bracelet watch	ساعة سوار/أسورة
34	coral necklace	عقد مرجان
35	charms	حليقات صغيرة
36	coin bracelet	سوار/أسورة مزودة بعملة ذهبية
37	gold coin	عملة ذهبية
38	coin setting	إطار تثبيت العملة
39	link	وصلة
40	signet ring	خاتم يخفر عليه الاسم
41	engraving (monogram)	حفر (مونوجرام)
42-86	cuts and forms	أنماط القطعيات والأشكال
42-71	faceted stones	الأحجار ذات الأوجه
42-43	standard round cut	القطع الدائري العادي
44	brilliant cut	القطع العاسي
45	rose cut	قطع وردية/نجمي الشكل
46	flat table	قطع مسطح
47	table en cabochon	سطح قبابي
48	standard cut	قطع عادي
49	standard antique cut	قطع أنتيكي عادي
50	rectangular step-cut	قطع درجي مستطيل
51	square step-cut	قطع درجي مربع
52	octagonal step-cut	قطع درجي ثماني
53	octagonal cross-cut	قطع صليبي ثماني
54	standard pear-shape (pendeloque)	قطع بندولي عادي

55	marquise (navette)	قطع مركزي
56	standard barrel-shape	شكل برميل عادي
57	trapezium step-cut	قطع درجي ترابيزي (شكل المعين المشرف)
58	trapezium cross-cut	قطع صليبي ترابيزي
59	rhombus step-cut	قطع شكل المعين
60-61	triangular step-cut	القطع الدرجي المثلثي
62	hexagonal step-cut	قطع درجي متساوي السايقين
63	oval hexagonal cross- cut	قطع صليبي سداسي بيضوي
64	round hexagonal step- cut	قطع درجي سداسي مستدير
65	round hexagonal cross- cut	قطع صليبي سداسي مستدير
66	chequer-board cut	قطع كاروهات
67	triangle cut	قطع مثلثي
68-71	fancy cuts	أنماط القطع الرخفي
72-77	ring gemstones	الأحجار الكريمة الخاصة بالخواتم
72	oval flat table	وجه مسطح بيضوي
73	rectangular flat table	وجه مسطح مثلثي
74	octagonal flat table	وجه مسطح ثماني
75	barrel-shape	شكل برميل
76	antique table en cabochon	سطح أنتيكي قبابي
77	rectangular table en cabochon	سطح مستطيل قبابي
78-81	cabochons	الأشكال القبابية
78	round cabochon (simple cabochon)	قبابي دائري (قبابي بسيط)
79	high dome (high cabochon)	قبابي مرتفع
80	oval cabochon	قبابي بيضوي
81	octagonal cabochon	قبابي ثماني
82-86	spheres and pear- shapes	الأشكال الكروية والكمثرية
82	plain sphere	كروي أملس
83	plain pear-shape	كمثري أملس
84	faceted pear-shape	كمثري متعدد الأسطح/الأوجه
85	plain drop	قطرة عكساء
86	faceted briolette	كمثري بيضوي متعدد الأسطح
37	Types of Dwelling	أنواع المساكن
1-53	detached house	منزل منفصل
1	basement	طابق تحت الأرض (بدروم)
2	ground floor (Am. first floor)	طابق أرضي
3	upper floor (first floor, Am. second floor)	طابق علوي
4	loft	علية (ستدره)
5	roof, a gable roof (saddle roof, saddle- back roof)	سطح الميثي، سطح جملوني
6	gutter	مزاب
7	ridge	حرف الجمون
8	verge with bargeboards	حافة الأواح خشبية
9	eaves, rafter-supported eaves	إفريز، رفرف السطح
10	chimney	مدخنة
11	gutter	مزاب
12	swan’s neck (swan- neck)	عنق إوزة
13	rainwater pipe (down- pipe, Am. downspout, leader)	مأسورة تصريف ماء المطر
14	vertical pipe, a cast- iron pipe	مأسورة من الحديد الزهر
15	gable (gable end)	جملون (طرف جملوني)
16	glass wall	جدار زجاجي
17	base course (plinth)	مدماك قاعدة الميثي
18	balcony	بلكون، شرفة
19	parapet	حاجز الشرفة
20	flower box	صندوق وضع الزهور
21	French window (French windows (opening on to the balcony)	شباك فرنسي يفتح على الشرفة
22	double casement window	شباك ذو ضلعتين
23	single casement window	شباك ذو ضلعة واحدة
24	window breast with window sill	صدر النافذة وبه عتبة النافذة
25	lintel (window head)	رأس النافذة
26	reveal	حافة الجدار حول النافذة (أو الباب)
27	cellar window	نافذة البدروم/القبو
28	rolling shutter	شيش قابل للطي
29	rolling shutter frame	إطار الشيش
30	window shutter (fold- ing shutter)	شيش النافذة
31	shutter catch	شكل الشيش
32	garage with tool shed	كاراج/مراب به عتبر الأدوات
33	espalier	تغريشة
34	batten door (ledged door)	باب مصلع بالأواح خشبية
35	fanlight with mullion and transom	شراعة مزودة بعمود تقسيم واحدة مستعرضة
36	terrace	تراس، شرفة واسعة
37	garden wall with coping stones	جدار حديقة مزود بأحجار إفريز
38	garden light	مصباح الحديقة
39	steps	درجات سلم
40	rockery (rock garden)	حديقة صخرية
41	outside tap (Am. faucet) for the hose	صنبور خارجي لخراطوم الحديقة
42	garden hose	خراطوم الحديقة
43	lawn sprinkler	مرشحة العشب
44	paddling pool	خوض ماء مضمحل للأطفال
45	stepping stones	أحجار للخطو
46	sunbathing area (lawn)	منطقة الحمام الشمسي
47	deck-chair	كرسي قماش
48	sunshade (garden parasol)	شفاسة، شمسية
49	garden chair	كرسي حديقة

50 garden table	طاولة الحديقة	ing, multistory apartment house)
51 frame for beating carpets	إطار لتفويض السجاجيد	77 flat roof
52 garage driveway	ممر الجراج	78 pent roof (shed roof, lean-to roof)
53 fence, a wooden fence	سياج، سور خشبي	79 garage
54-57 housing estate (housing development)	منطقة إسكان، منطقة سكنية	80 pergola
54 house on a housing estate (on a housing development)	مَنْزِل في منطقة سكنية	81 staircase window
55 pent roof (penthouse roof)	سقف مَبْنَى جانبي مَلْحَق	82 high-rise block of flats (Am. high-rise apartment building, high-rise apartment house)
56 dormer (dormer window)	شِبَاك جَمَلُون بارز	83 penthouse
57 garden	حديقة	84-86 weekend house, a timber house
58-63 terraced house [one of a row of terraced houses], stepped	مَنْزِل في صف من المنازل مَلْتَصِق كل منهما بالآخر	84 horizontal boarding
58 front garden	حديقة أمامية	85 natural stone base course (natural stone plinth)
59 hedge	سياج	86 strip windows (ribbon windows)
60 pavement (Am. sidewalk, walkway)	مَسْطَى جانبي، رصيف	38 Roof and Boiler Room
61 street (road)	شارع (طريق)	1-29 attic
62 street lamp (street light)	فانوس الشارع	1 roof cladding (roof covering)
63 litter bin (Am. trash bin)	صفيحة نفايات	2 skylight
64-68 house divided into two flats (Am. house divided into two apartments, duplex house)	مَنْزِل مَقْسَم إلى شَقَتَيْن (بَيْت دُوبَلِكس)	3 gangway
64 hip (hipped) roof	سقف مُسْتَم	4 cat ladder (roof ladder)
65 front door	باب أمامي	5 chimney
66 front steps	دَرَجَات سَلَم أمامي	6 roof hook
67 canopy	مظلة، تende	7 dormer window (dormer)
68 flower window (window for house plants)	نافذة لتعليق الزهور	8 snow guard (roof guard)
69-71 pair of semi-detached houses divided into four flats (Am. apartments)	مَنْزِلان متصلاَن ببعضهما من جانب واحد فقط مقسماَن إلى أربع شقق (Am. apartments)	9 gutter
69 balcony	بلكونة، شرفة	10 rainwater pipe (down-pipe, Am. downspout, leader)
70 sun lounge (Am. sun parlor)	استراحة، غرفة جلوس	11 eaves
71 awning (sun blind, sun-shade)	ظَلَّة، تَنْدَة	12 pitched roof
72-76 block of flats (Am. apartment building, apartment house) with access balconies	مَبْنَى سَكْنِي، مجموعة شقق سكنية	13 trapdoor
72 staircase	بَيْت الدَّرَج	14 hatch
73 balcony	بلكون، شرفة	15 ladder
74 studio flat (Am. studio apartment)	شقة ستوديو	16 stile
75 sun roof, a sun terrace	شرفة شمسية	17 rung
76 open space	منطقة مفتوحة	18 loft (attic)
77-81 multi-story block of flats (Am. multi-story apartment building)	مَبْنَى سَكْنِي مُتَعَدِّد الطوابق	19 wooden partition
		20 lumber room door (boxroom door)
		21 padlock
		22 hook [for washing line]
		23 clothes line (washing line)
		24 expansion tank for boiler
		25 wooden steps and

balustrade	عارضة جانبية	26 string (Am. stringer)	درجة سلم
27 step	مَسْكَا الدرابزين	28 handrail (guard rail)	عمود الدرابزين
29 baluster	واقية الصواعيق	30 lightning conductor (lightning rod)	مَنْظَف المِدْحَنَة
31 chimney sweep (Am. chimney sweeper)	فُرْشَاة مَرْوْدَة بَقْل	32 brush with weight	حديقة الكف
33 shoulder iron	كيس للسناج	34 sack for soot	فُرْشَاة مَسْرَب المِدْحَنَة
35 flue brush	مِكْسَة	36 broom (besom)	عصا المِكْسَة
37 broomstick (broom handle)	نظام تسخين الماء، تسخين مركزي كامل	38-81 hot-water heating system, full central heating	حجرة المرجل/الغلاية
38-43 boiler room	نظام تسخين مركزي يحمل بحرق الكوك	38-43 boiler room	باب صندوق الرماد
39 ash box door (Am. cleanout door)	كلية مسرب المدخنة	39 coke-fired central heating system	محرّك (الجَنَر)، مِسْجَار مِدْمَة
40 flueblock	نظام تسخين مركزي يعمل بحرق الزيت	40 flueblock	جاروف الفحم
41 poker	باب صندوق الرماد	41 poker	نظام تسخين مركزي يعمل بحرق الزيت
42 rake	كوكبة مسرب المدخول	42 rake	صهرج الزيت
43 coal shovel	غطاء فتحة الدخول	43 coal shovel	فتحة الدخول
44-60 oil-fired central heating system	غطاء فتحة الدخول	44-60 oil-fired central heating system	مَنْحَل/مَنْفَذ الصهرج
44 oil tank	غطاء قبابي	44 oil tank	صمام قاع الصهرج
45 manhole cover	زيت وفود (زيت تدفئة)	45 manhole cover	مأسورة التهوية
46 manhole cover	غطاء فتحة التهوية	46 manhole cover	أنتوب مستوي الزيت
47 tank inlet	مقياس الزيت	47 tank inlet	مقياس الزيت
48 dome cover	مأسورة ماصة	48 dome cover	أنتوب إرجاع
49 tank bottom valve	فرن التسخين المركزي (فرن التسخين بالزيت)	49 tank bottom valve	حارق زيتي
50 fuel oil (heating oil)	محرّك كهربائي	50 fuel oil (heating oil)	مروحة
51 air-bleed duct	ضوء إرشادي مغلف	51 air-bleed duct	بوابة الإقلام
52 air vent cap	نافذة المعاينة	52 air vent cap	مقياس الماء
53 oil level pipe	ترمومتر الفرن	53 oil level pipe	محرّك كهربائي
54 oil gauge (Am. gage)	مقياس صرّف	54 oil gauge (Am. gage)	قاعدة الفرن
55 suction pipe	لوحة التحكم	55 suction pipe	صهرج الماء الساخن (الغلاية)
56 return pipe	صهرج الماء الساخن (الغلاية)	56 return pipe	
57 central heating furnace (oil heating furnace)		57 central heating furnace (oil heating furnace)	
58-60 oil burner		58-60 oil burner	
58 fan		58 fan	
59 electric motor		59 electric motor	
60 covered pilot light		60 covered pilot light	
61 charging door		61 charging door	
62 inspection window		62 inspection window	
63 water gauge (Am. gage)		63 water gauge (Am. gage)	
64 furnace thermometer		64 furnace thermometer	
65 bleeder		65 bleeder	
66 furnace bed		66 furnace bed	
67 control panel		67 control panel	
68 hot water tank (boiler)		68 hot water tank (boiler)	

69 overflow pipe (overflow)	أنبوب الفائض	77 radiator rib	ضلع المشع
70 safety valve	صمام تنظيم	78 room thermostat	ترموستات الحجرة
71 main distribution pipe	أنبوب إرجاع	79 return pipe (return)	أنبوب إرجاع
72 lagging	أنبوب إرجاع [في النظام ثنائي الأنابيب]	80 return pipe [in two-pipe system]	فتحة خروج الدخان
73 valve	صمام تنظيم	81 smoke outlet (smoke extract)	
74 flow pipe	من الغلاية	39 Kitchen	المطبخ
75 regulating valve	صمام تنظيم	1 microwave oven (microwave)	فرن ميكروويف
76 radiator	صانع المشع	2 refrigerator (fridge, Am. icebox)	ثلاجة
77 radiator rib	ترموستات الحجرة	3 refrigerator shelf	رفف الثلاجة
78 room thermostat	أنبوب إرجاع	4 salad drawer	دُرُج الخضروات
79 return pipe (return)	أنبوب إرجاع [في النظام ثنائي الأنابيب]	5 freezing compartment	حجرة الأظلمة المجمدة
80 return pipe [in two-pipe system]	فتحة خروج الدخان	6 bottle rack (in storage door)	رفف القنبيات (في باب الثلاجة)
81 smoke outlet (smoke extract)		7 upright freezer	فريزر رأسي
		8 wall cupboard, a kitchen cupboard	دُوبَل مطبخ
		9 base unit	وحدة القاعدة
		10 cutlery drawer	دُرُج لوازم المائدة (من سكاكين وفضية)
		11 work surface (worktop)	تسطح الشغل
		12-17 cooker unit	وحدة الطبخ، جهاز الطبخ
		12 electric cooker (also: gas cooker)	طباخ (بوتوجاز) كهربائي
		13 oven	فرن
		14 oven window	نافذة الفرن
		15 hotplate, an automatic high-speed plate	مؤدق (عين) البوتوجاز
		16 kettle (whistling kettle)	غلاية
		17 cooker hood	غطاء جهاز الطبخ
		18 pot holder	حامل أواني الطبخ
		19 pot holder rack	علاقة حامل أواني الطبخ
		20 kitchen clock	ساعة المطبخ
		21 timer	جهاز توقيت
		22 hand mixer	خلاط يدوي
		23 whisk	مِغْفَقَة (البيض، الخ.)
		24 electric coffee grinder (with rotating blades)	مِلْحَنَة بِن كهربائية (ذات مفاصل دوارة)
		25 lead	سلك توصيل
		26 wall socket	مقبس جداري
		27 corner unit	وحدة الزاوية
		28 revolving shelf	رفف دوار
		29 pot (cooking pot)	وعاء/إناء للطهي
		30 jug	إبريق

- 31 spice rack رف التوابل
 32 spice jar مرطمان/برطمان توابل
33-36 sink unit وحدة حوض الغسيل
 33 dish drainer حامل تجفيف الأطباق
 34 tea plate طبق صغير
 35 sink حوض المطبخ
 36 water tap (*Am.* faucet); here: mixer tap (*Am.* mixing faucet) حنفية/صنبور الماء هنا صنبور خلط
 37 pot plant, a foliage plant نبات زينة فى ايصيص
 38 coffee maker جهاز إعداد القهوة
 39 kitchen lamp مصباح المطبخ
 40 dishwasher (dish-washing machine) غسالة أطباق
 41 dish rack رف أطباق
 42 dinner plate طبق واسع مقلع
 43 kitchen chair كرسي مطبخ
 44 kitchen table طاولة مطبخ
 45 toaster توستر، مخصصة خبز كهربائية
- 40 Kitchen Utensils and Appliances** أدوات وأجهزة المطبخ
 1 general-purpose roll holder with kitchen roll (paper towels) حامل مناشيف ورقية متعدد الأغراض
 2 set of wooden spoons طاقم ملاعق خشبية
 3 mixing spoon ملعقة قلب (كشبة)
 4 frying pan قلاية، إناء القلي
 5 Thermos jug ترمس
 6 set of bowls طاقم سلطانيات/زبونيّات
 7 cheese dish with glass cover طبق جبن له غطاء زجاجي
 8 three-compartment dish صينية مقسمة إلى ثلاث حجزات
 9 lemon squeezer عصارة ليمون
 10 whistling kettle غلاية مياه (تصدّر صغيراً عند الغلي)
 11 whistle صفارة تحذير
12-16 pan set طاقم أواني الطهي
 12 pot (cooking pot) وعاء/قدر مطبخ
 13 lid غطاء
 14 casserole dish قدر فخاري، برام
 15 milk pot لبنانة، وعاء اللبن
 16 saucepan كسرولة
 17 immersion heater مسخن كهربائي غاطس
 18 corkscrew [with levers] برزمية نزع السدادات الفلينية [ذات أذرع]
 19 juice extractor عصارة
 20 tube clamp (tube clip) ماسك الأنبوب
 21 pressure cooker جهاز طبخ يعمل بالضغط
 22 pressure valve صمام ضغط
 23 fruit preserver آلية حفظ الفاكهة
 24 removable rack حامل قابل للفصل
 25 preserving jar إبريق حفظ (مواد غذائية)
 26 rubber ring حلقة مطاطية
 27 spring form قالب مژود بناهض
 28 cake tin صينية كيك

- 29 cake tin صينية كيك
 30 microwave oven فرن ميكروويف (microwave)
 31 timer جهاز توقيت
 32 rotisserie مشواة، شواية
 33 spit سفود، سيخ
 34 electric waffle iron مخصصة "وقل" كهربائية
 35 sliding-weight scales ميزان مطبخ ذو ثقل انزلاقي/متحرك
 36 sliding weight ثقل منزلق/انزلاقي
 37 scale pan كفة الميزان
 38 food slicer مشرحة الطعام
 39 mincer (*Am.* meat chopper) فرامة اللحم، فرمة
 40 blades ريش/أضال المفرمة
 41 chip pan وعاء الشرائع
 42 basket سلة
 43 potato chipper ماكينة تقطيع البطاطس إلى شرائح ورقائق
 44 yoghurt maker جهاز إعداد الزبادي
 45 mixer خلط
 46 blender المؤلف، جهاز المزج
 47 bag sealer جهاز إحكام قفل الأكياس البلاستيكية

- 41 Hall** الصالة
1-29 hall (entrance hall) الصالة (رؤمة المدخل)
 1 coat rack حاملّة، علاقة الملابس
 2 coat hook خنطاف تعليق
 3 coat hanger شماعة ملابس
 4 rain cape رداء خارجي قفصافض
 5 walking stick واق من المطر
 6 hall mirror عكاز، عصا المشي
 7 telephone مرآة الصالة
 8 chest of drawers for shoes, etc. هاتف، تليفون
 9 drawer خزانة ذات أذراع لحفظ الأحذية، الخ.
 10 seat درج
 11 ladies' hat مقعد
 12 telescopic umbrella قبة نسائية
 13 tennis rackets (tennis racquets) مظلة/مداخلة الأجزاء
 14 umbrella stand مبطنياً لعبة التنس الأرضي
 15 umbrella حامل الشماسي
 16 shoes مظلة، شمسية
 17 briefcase زوج من الأحذية
 18 fitted carpet حقيبة يد
 19 fuse box بنشاط/سجادة تغطي الأرضية بالكامل
 20 miniature circuit breaker صندوق الفيوزات الكهربائية قاطع تيار صغير المدى
 21 tubular steel chair كرسي معدني ذو هيكل أنبوبي الشكل
 22 stair light مصباح الذراج/السلم
 23 handrail ممكأ الدوابزين
 24 step درجة سلم
 25 front door باب أمامي
 26 door frame إطار الباب

- 27 door lock قفل الباب
 28 door handle مقبض الباب
 29 spyhole عين سخرية
- 42 Living Room** غرفة المعيشة
1-20 wall units (shelf units) وحدات حائطية (وحدات أرفق)
 2 side wall جدار جانبي
 3 bookshelf رف كتب
 4 row of books صف من الكتب
 5 display cabinet unit خزانة قاعدة الدواب
 6 cupboard base unit خزانة، صوان
 7 cupboard unit ثقفان
 8 television set (TV set) جهاز ستريو
 9 stereo system (stereo equipment) سماعة صوت، مكبر صوت
 10 speaker (loudspeaker) حامل التليفون
 11 pipe rack غليون
 12 pipe كورة أرضية
 13 globe غلاية نحاسية
 14 brass kettle تليسكوب
 15 telescope ساعة رف
 16 mantle clock تمثال نصفي
 17 bust مؤسوعة [فى عدة مجلدات]
 18 encyclopaedia [in several volumes] حاجز/فاصل الغرفة
 19 room divider خزانة/صوان المشروبات (بار)
 20 drinks cupboard طاقم جلوس منجد
- 21-26 upholstered suite** (seating group) كرسي ذو مسدين
 21 armchair ذراع، مسند
 22 arm وسادة مقعد
 23 seat cushion (cushion) كنية/أريكة منجدة
 24 settee مسند/وسادة الظهر
 25 back cushion جزء الزاوية [المستدير]
 26 [round] corner section طاولة القهوة/الشاى
 27 scatter cushion مفضة السجائر
 28 coffee table صينية
 29 ashtray زجاجة ويسكي
 30 tray صينية
 31 whisky (whiskey) bottle زجاجة ماء الصودا
 32 soda water bottle (soda bottle) زجاجة ماء الصودا
33-34 dining set طاقم طاولة الطعام
 33 dining table طاولة طعام
 34 chair كرسي
 35 net curtain سبارة شبكية
 36 indoor plants (house-plants) نباتات منزلية/داخلية
- 43 Bedroom** غرفة النوم
 1 wardrobe (*Am.* clothes closet) دولاب/صوان الملابس
 2 linen shelf رف البياضات
 3 cane chair كرسي من الفس والحيزران
4-13 double bed (*sim.*: سرير مژود/لشخصين double divan)

- 4-6 bedstead** هيكل السرير
 4 foot of the bed اللوحة السفلية
 5 bed frame منضب
 6 headboard اللوحة الرأسية
 7 bedspread مفروش/غطاء السرير
 8 duvet, a quilted duvet دوفيت، حاف
 9 sheet, a linen sheet ملادة
 10 mattress, a foam mattress with drill tick مرتبة، حنيفة (لها كيس من الكتان أو القطن)
 11 [wedge-shaped] bolster مخدة، وسادة إسفينية [الشكل]
12-13 pillow وسادة، مخدة
 12 pillowcase (pillowslip) كيس مخدة/وسادة
 13 tick غلاف الوسادة
 14 bookshelf [attached to the headboard] رف كتب (معلق باللوحة الرأسية)
 15 reading lamp مصباح للقراءة
 16 electric alarm clock ساعة كهربائية مژودة ببنية
 17 bedside cabinet خزانة بجانب السرير (كومودينو)
 18 drawer درج
 19 bedroom lamp مصباح غرفة النوم
 20 picture صورة
 21 picture frame إطار/برواز الصورة
 22 bedside rug سجادة/سباط صغير
 23 fitted carpet سباط (يفعل الأرضية بالكامل)
 24 dressing stool كرسي المرزنية/التشريحة
 25 dressing table المرزنية، التشريحة
 26 perfume spray مرشحة عطر
 27 perfume bottle قنبية عطر
 28 powder box علبة بودرة
 29 dressing-table mirror (mirror) مرآة المرزنية
- 44 Dining Room** غرفة الطعام
1-11 dining set طاقم طاولة الطعام
 1 dining table مائدة/طاولة الطعام
 2 table leg قائمة/رجل الطاولة
 3 table top سطح الطاولة
 4 place mat مفروش صغير (يوضع أمام كل جالس)
 5 place (place setting, cover) مؤضع/مكان (الأحد الجالسين)
 6 soup plate (deep plate) طبق الحساء (طبق عميق)
 7 dinner plate طبق واسع مقلع
 8 soup tureen سلطانية الحساء
 9 wineglass كأس
 10 dining chair كرسي طاولة الطعام
 11 seat مقعد الكرسي
 12 lamp (pendant lamp) مصباح (مادلى من السقف)
 13 curtains ستائر
 14 net curtain ستارة شبكية
 15 curtain rail قضيب تعليق الستارة
 16 carpet سجادة، سباط
 17 wall unit وحدة حائطية
 18 glass door باب زجاجي
 19 shelf رف
 20 sideboard بوفيه، صوان لوازم

21	cutlery drawer	المائدة دُرَج لَوَازِم المائدة
22	linen drawer	دُرَج البِيَاضَات (مَقَارِش وفوط المائدة)
23	base	قاعدة
24	round tray	صينية مُستديرة
25	pot plant	نبات (زينة) في أصيص
26	china cabinet (display cabinet)	دولاب نيش
27	coffee set (coffee service)	طاقم القهوة
28	coffee pot	دلة/ روكوة القهوة
29	coffee cup	فنجان القهوة
30	saucer	طبق الفنجان
31	milk jug	إبريق اللبن (المائدة)
32	sugar bowl	سكّرتة (وعاء السكر)
33	dinner set (dinner service)	طاقم صيني للمائدة
45	Tableware and Cutlery	مَقَارِش و لَوَازِم المائدة
1	dining table	مائدة/ طاولة الطعام
2	tablecloth, a damask cloth	مفرش المائدة، مفرش ديباج
3-12	place (place setting, cover)	موضع جالس إلی المائدة
3	bottom plate	طبق سفلي
4	dinner plate	طبق واسع مُقلّط
5	deep plate (soup plate)	طبق عميق (طبق حساء)
6	dessert plate (dessert bowl)	طبق الطور (الحلوى أو الفاكهة)
7	knife and fork	سكين وشوكة
8	fish knife and fork	سكين وشوكة الأسماك
9	serviette (napkin, table napkin)	فوطه المائدة
10	serviette ring (napkin ring)	حلقة فوط المائدة
11	knife rest	مسند السكاكين
12	wineglasses	كؤوس الخمر
13	place card	بطاقة (تُخَمَل اسم صاحب الموَضِع)
14	soup ladle	مغرفة الحساء
15	soup tureen	سلطانية الحساء
16	candelabra	شمعدان
17	sauceboat (gravy boat)	قارب الصلصة/ المرق
18	sauce ladle (gravy ladle)	مغرفة الصلصة/ المرق
19	table decoration	زينة المائدة
20	bread basket	سلة الخبز
21	roll	رغيف إفرنجي صغير
22	slice of bread	كسرة/ شريحة خبز
23	salad bowl	طبق السلطة
24	salad servers	شوكة وملقعة لتقديم السلطة
25	vegetable dish	طبق الخضروات
26	meat plate (Am. meat platter)	طبق اللحوم
27	roast meat (roast)	لحم مشوي (شواء)
28	fruit dish	طبق الفاكهة
29	fruit bowl	طبق فاكهة (صغير)

30	fruit (stewed fruit)	فاكهة (فاكهة مطبوخة)
31	potato dish	طبق البطاطس
32	serving trolley	تrolley لتقديم الطعام
33	vegetable plate (Am. vegetable platter)	طبق الخضروات
34	toast	خبز مُحمص
35	cheeseboard	قالب الجبن
36	butter dish	طبق الزبد
37	open sandwich	شطيرة
38	filling	حشو
39	sandwich	سندوتش
40	fruit bowl	طبق فاكهة
41	almonds (also: potato crisps, peanuts)	لوز (أيضاً رقائق البطاطس، فول سوداني)
42	oil and vinegar bottle	قنينة الزيت والخل
43	ketchup (catsup, catsup)	كاتشب (مصلصة من الطماطم أو الفلفل)
44	sideboard	بوفيه (ضوان جانبي)
45	electric hotplate	موقد كهربائي
46	corkscrew	فتاحة سدادات فلينية
47	crown cork bottle opener (crown cork opener), a bottle opener	فتاحة قنينات ذات سدادات فلينية
48	liqueur decanter	دورق للخمر
49	nutcrackers (nut-cracker)	كسارة بندق
50	knife	سكين
51	handle	مقبض
52	lang (tongue)	لسان السكين
53	ferrule	طويق معدني
54	blade	نصل
55	bolster	سناد
56	back	الطرف الخلفي للنصل
57	edge (cutting edge)	حافة (الحافة القاطعة)
58	fork	شوكة
59	handle	مقبض
60	prong (tang, tine)	إحدى شُعب الشوكة
61	spoon; here: dessert spoon, soup spoon	ملقعة (ملقعة متوسطة الخجم، ملقعة شورتية/ حساء)
62	handle	مقبض
63	bowl	بطن الملقعة
64	fish knife	سكين الأسماك
65	fish fork	شوكة الأسماك
66	dessert spoon (fruit spoon)	ملقعة الحلوى أو الفاكهة
67	salad spoon	ملقعة السلطة
68	salad fork	شوكة السلطة
69-70	carving set (serving cutlery)	طاقم تقطيع الشواء
69	carving knife	سكين تقطيع الشواء
70	serving fork	شوكة تقديم الشواء
71	fruit knife	سكين الفاكهة
72	cheese knife	سكين الجبن
73	butter knife	سكين الزبد
74	vegetable spoon, a serving spoon	ملقعة تقديم الخضروات
75	potato server (serving spoon for potatoes)	ملقعة تقديم البطاطس

76	cocktail fork	شوكة الكوكتيل
77	asparagus server (asparagus slice)	ملقعة تقديم الهليون
78	sardine server	شوكة تقديم السردين
79	lobster fork	شوكة تقديم جراد البحر
80	oyster fork	شوكة تقديم المحار
81	caviare knife	سكين تقديم الكافيار
82	white wine glass	كأس نبيذ أبيض
83	red wine glass	كأس نبيذ أحمر
84	sherry glass (madeira glass)	كأس نبيذ الشري
85-86	champagne glasses	كأسا الشمبانيا
85	tapered glass	كأس مستدقة الطرف
86	champagne glass, a crystal glass	كأس شمبانيا كريستال
87	rummer	قدح أو كؤوب كبير
88	brandy glass	كأس البراندی
89	liqueur glass	كأس مشروب مسكر
90	spirit glass	كأس مشروب كحولی
91	beer glass	كؤوب البيرة (الجعة)
46	Flat (Apartment)	الشقة
1	wall units (shelf units)	وحدات حائطية (أرفف)
2	wardrobe door (Am. clothes closet door)	باب ضوان الملابس
3	body	جسم الصوان
4	side wall	جدار جانبي
5	trim	حافة خشبية زخرفية
6	two-door cupboard unit	خزانة ذات بابين
7	bookshelf unit (bookcase unit) [with glass door unit]	وحدة رف الكتب [ذات باب زجاجي]
8	books	كتب
9	display cabinet	دولاب نيش
10	record player	جهاز بيك أب، جهاز تشغيل الأسطوانات
11	drawer	دُرَج
12	decorative biscuit tin	علبة بسكويت زخرفية
13	soft toy animal	لعبة طرية على شكل حيوان
14	television set (TV set)	تلفاز
15	records (discs)	تسجيلات
16	bed unit	وحدة السرير
17	scatter cushion	وسادة صغيرة
18	bed unit drawer	دُرَج السرير
19	bed unit shelf	رف السرير
20	magazines	مجلات
21	desk unit (writing unit)	وحدة المكتب
22	desk	مكتب، طاولة الكتابة
23	desk mat (blotter)	سُدافة
24	table lamp	مصباح طاولة
25	wastepaper basket	سلة مهملات
26	desk drawer	دُرَج المكتب
27	desk chair	كرسي المكتب
28	arm	مسند/ ذراع الكرسي
29	kitchen unit	وحدة المطبخ
30	dump cupboard	خزانة قاذط
31	cooker hood	غطاء الطبخ/ جهاز الطبخ
32	electric cooker	جهاز طبخ كهربائي
33	refrigerator (fridge,	ثلاجة
	Am. icebox)	
34	dining table	طاولة الطعام
35	table runner	مفرش مائدة مزخرف
36	oriental carpet standard lamp	سجادة/ بساط شرقي مصباح أعلى حامل عمودي
47	Children's Room (Nursery)	غرفة الأطفال (حجرة نوم الطفل)
1	children's bed, a bunkbed	سرير طفل
2	storage box	صندوق تخزين
3	mattress	حشية، مرتبة
4	pillow	مخددة، وسادة
5	ladder	سلم تقالي
6	soft toy elephant, a cuddly toy animal	لعبة طرية على شكل فيل
7	soft toy dog	لعبة طرية على شكل كلب
8	cushion	وسادة
9	fashion doll	دمية أزياء
10	doll's pram	عربة أطفال للدمية
11	sleeping doll	دمية نائمة
12	canopy	غطاء، مظلة
13	blackboard	سبورة
14	counting beads	خرزات تعليم العد
15	toy horse for rocking and pulling	حصان لعبة هزاز
16	rockers	مهورات الحصان
17	children's book	كتاب أطفال
18	pendium of games	مجموعة من الألعاب
19	ludo	لعبة اللودو
20	chessboard	رقعة الشطرنج
21	children's cupboard	دولاب ملابس أطفال
22	linen drawer	دُرَج البياضات
23	drop-flap writing surface	سطح كتابة قلاب
24	notebook (exercise book)	دفتر (كتاب التمارين)
25	school books	كتب مدرسية
26	pencil (also: crayon, felt tip pen, ballpoint pen)	قلم رصاص (أيضاً قلم جبر سائل ذو طرف لبادي أو طرف كروي)
27	toy shop	متجر اللعب
28	counter	كاؤنتر (منضدة التاجر)
29	spice rack	حامل قنينات التوابل
30	display	مغروضات
31	assortment of sweets (Am. candies)	حلويات مُشكلة (حلوى)
32	bag of sweets (Am. candies)	كيس حلوى
33	scales	ميزان
34	cash register	سُنبيكة النقد
35	toy telephone	هاتف لعبة
36	shop shelves (goods shelves)	أرفف المتجر (أرفف البضائع)
37	wooden train set	طاقم قطار خشبي لعبة
38	dump truck, a toy lorry (toy truck)	شاحنة قلابة لعبة
39	tower crane	وش/ مرفاع بُرجي
40	concrete mixer	خلّاط خرسانة

36 stile	مُرْفِي دَرَجِي
37 prop	دُعَامَةٌ، مَسْتَد
38 tread (rung)	مُوطِي (دَرَجَةٌ)
39-43 shoe care utensils	أدوات العناية بالأحذية
39 tin of shoe polish	عَلْبَةٌ وَرْنِيشٍ أَحْدِيَّةِ
40 shoe spray, an impregnating spray	وَرْنِيشٍ سَائِلٍ يَرَشُّ عَلَى الْأَحْدِيَّةِ
41 shoe brush	فُرْشَاةٌ أَحْدِيَّةِ
42 brush for applying polish	فُرْشَاةٌ دَهْنُ الْوَرْنِيشِ
43 tube of shoe polish	أَنْبُوبٌ وَرْنِيشٍ أَحْدِيَّةِ
44 clothes brush	فُرْشَاةٌ مَلَابِسِ
45 carpet brush	فُرْشَاةٌ سَجَاجِدِ
46 broom	مِكْنَسَةٌ
47 bristles	فَلْبٌ شَعْرٌ خَشِنٌ
48 broom head	رَأْسُ الْمِكْنَسَةِ
49 broomstick (broom handle)	عَصَا الْمِكْنَسَةِ
50 screw thread	أَسْنَانُ الثَّرَاثِ
51 washing-up brush	فُرْشَاةٌ لِكْسَانِ
52 pan (dustpan)	جَارُوفٌ جَمْعُ التَّرَابِ
53-86 floor and carpet cleaning	تَنْظِيفُ الْأَرْضِيَّةِ وَ السَّجَادِ
53 brush	فُرْشَاةٌ
54 bucket (pail)	دَلْوٌ (جَرْدَلٌ)
55 floor cloth (cleaning rag)	مِمْسَحَةٌ
56 scrubbing brush	فُرْشَاةٌ الْبِلَاطِ
57 carpet sweeper	مِكْنَسَةٌ سَجَاجِدِ
58 upright vacuum cleaner	مِكْنَسَةٌ كَهْرَبَائِيَّةٌ عَمُودِيَّةٌ
59 changeover switch	مِفْتَاحُ تَحْوِيلِ
60 swivel head	رَأْسٌ تَدَوَّرُ عَلَى مِجْوَرٍ
61 bag-full indicator	مُؤَشِّرٌ امْتِلَاءِ كَيْسِ الْأَثْرِيَّةِ
62 dust bag container	حَاوِيَةٌ كَيْسِ الْأَثْرِيَّةِ
63 handle	مِقْبَضٌ
64 tubular handle	ذِرَاعٌ أَنْبُوبِي
65 flex hook	خَطَافٌ مَرْنٌ/قَابِلٌ لِلإِنْتِشَاءِ
66 wound-up flex	كَيْبِلٌ مَغْرُولٌ مَرْنٌ
67 all-purpose nozzle	مِنْفَذٌ لِكُلِّ الْأَغْرَاضِ
68 cylinder vacuum cleaner	مِكْنَسَةٌ كَهْرَبَائِيَّةٌ اسطوانيَّةٌ
69 swivel coupling	وَسَلَّةٌ تَرَاوِحِيَّةٌ
70 extension tube	أَنْبُوبٌ تَمْدِيدٌ
71 floor nozzle (sim.: carpet beater nozzle)	مِنْفَذٌ لِكُلِّ تَنْظِيفِ الْأَرْضِيَّةِ
72 suction control	مِفْتَاحُ التَّحَكُّمِ فِي الشَّفْطِ
73 bag-full indicator	مُؤَشِّرٌ امْتِلَاءِ كَيْسِ الْأَثْرِيَّةِ
74 sliding fingertip suction control	مِفْتَاحُ انزلاقي للتحكم في الشفط
75 hose (suction hose)	خَرْطُومٌ (خَرْطُومُ الشَّفْطِ)
76 combined carpet sweeper and shampooer	مَاكِينَةٌ كَتَسَ السَّجَاجِدِ وَغَسَلَهَا بِالنَّشَامِيُو
77 electric lead (flex)	كَيْبِلٌ مَغْرُولٌ مَرْنٌ
78 plug socket	مِقْبَسٌ
79 carpet beater head (sim.: shampooing head, brush head)	رَأْسُ كَتَسِ السَّجَادِ وَغَسِيلِهِ بِالنَّشَامِيُو
80 all-purpose vacuum	مِكْنَسَةٌ كَهْرَبَائِيَّةٌ لِكُلِّ

36 stile	خِرَازِمَةُ أُدْوِيَّةِ
37 prop	الأجهزة والأدوات المنزلية
38 tread (rung)	المكايي
39-43 shoe care utensils	ماكينة كي كهربائية
39 tin of shoe polish	مِفْتَاحٌ كَهْرَبَائِيَّةٌ يَتِمُّ تَشْوِيقُهُ بِالْقَدَمِ
40 shoe spray, an impregnating spray	غَطَاءُ الْأَسْطِوانَةِ
41 shoe brush	رَأْسُ الْكَبِّيِّ
42 brush for applying polish	مَلَاءَةٌ
43 tube of shoe polish	بِكْوَاةٌ كَهْرَبَائِيَّةٌ (مِكْوَاةٌ خَفِيفَةٌ)
44 clothes brush	نَمَلُ الْمِكْوَاةِ
45 carpet brush	فَرَصٌ اخْتِيَارِ دَرَجَةِ الْحَرَارَةِ
46 broom	مِقْبَضٌ (مِقْبَضُ الْمِكْوَاةِ)
47 bristles	ضَوْءٌ إِرْشَادِي
48 broom head	مِكْوَاةٌ الْكَبِّيِّ بِالْبَخَارِ وَرَزَّازِ الْمَاءِ وَالْكَبِّيِّ الْجَافِ
49 broomstick (broom handle)	مِفْتَاحٌ إِدْخَالِ التَّمَاءِ
50 screw thread	قُوَّةُ الرَزَّازِ لَتَرْطِيبِ الْعَسِيلِ
51 washing-up brush	فَمَّخَةٌ خُرُوجِ الْبَخَارِ
52 pan (dustpan)	مَطاوِلَةُ الْكَبِّيِّ
53-86 floor and carpet cleaning	سَطْحُ الْكَبِّيِّ
53 brush	غَطَاءُ سَطْحِ الْكَبِّيِّ
54 bucket (pail)	حَاوِيَةٌ الْمِكْوَاةِ، بَثْرُ الْمِكْوَاةِ
55 floor cloth (cleaning rag)	إِطَارٌ مِنَ الْأَلومِينِيُومِ
56 scrubbing brush	لَوْحَةٌ كَبِّيِّ الْأَحْكَامِ
57 carpet sweeper	وَعَاءُ الْغَسِيلِ
58 upright vacuum cleaner	غَسِيلٌ مُتَمَسِّخٌ
59 changeover switch	الغسالات الكهربائية والمخففات
60 swivel head	غَسَالَةٌ آليَّةٌ
61 bag-full indicator	أَسْطِوانَةُ الْغَسَالَةِ
62 dust bag container	مَرْدَاجٌ تَنْبِيْتُهِ لِلأَمَانِ
63 handle	فَرَصُ التَّحَكُّمِ فِي اخْتِيَارِ البرنامِجِ
64 tubular handle	مُوزَعٌ صَابُونِ أَمَامِي [مَتَعَدِّدِ الْحِجْرَاتِ]
65 flex hook	مُخَفِّفٌ دَوَّارٌ
66 wound-up flex	أَسْطِوانَةٌ، بِرَمِيلٌ
67 all-purpose nozzle	بَابٌ أَمَامِي ذُو فَتَحَاتٍ تَهْوِيَّةِ
68 cylinder vacuum cleaner	سَطْحُ الشُّغْلِ
69 swivel coupling	مَتَشِّرٌ غَسِيلِ
70 extension tube	حَبْلٌ شَرُّ الْغَسِيلِ
71 floor nozzle (sim.: carpet beater nozzle)	مَتَشِّرٌ غَسِيلِ اِمْتِدَادِي
72 suction control	سَلْمٌ نَقَالِي
73 bag-full indicator	
74 sliding fingertip suction control	
75 hose (suction hose)	
76 combined carpet sweeper and shampooer	
77 electric lead (flex)	
78 plug socket	
79 carpet beater head (sim.: shampooing head, brush head)	
80 all-purpose vacuum	

49 medicine cabinet	خِزانة أدوية
50 Household Appliances and Utensils	الأجهزة والأدوات المنزلية
1-20 irons	المكايي
1 electric ironing machine	ماكينة كي كهربائية
2 electric foot switch	مِفْتَاحٌ كَهْرَبَائِيَّةٌ يَتِمُّ تَشْوِيقُهُ بِالْقَدَمِ
3 roller covering	غَطَاءُ الْأَسْطِوانَةِ
4 ironing head	رَأْسُ الْكَبِّيِّ
5 sheet	مَلَاءَةٌ
6 electric iron (light-weight iron)	بِكْوَاةٌ كَهْرَبَائِيَّةٌ (مِكْوَاةٌ خَفِيفَةٌ)
7 sole-plate	نَمَلُ الْمِكْوَاةِ
8 temperature selector	فَرَصٌ اخْتِيَارِ دَرَجَةِ الْحَرَارَةِ
9 handle (iron handle)	مِقْبَضٌ (مِقْبَضُ الْمِكْوَاةِ)
10 pilot light	ضَوْءٌ إِرْشَادِي
11 steam, spray, and dry iron	مِكْوَاةٌ الْكَبِّيِّ بِالْبَخَارِ وَرَزَّازِ الْمَاءِ وَالْكَبِّيِّ الْجَافِ
12 filling inlet	مِفْتَاحٌ إِدْخَالِ التَّمَاءِ
13 spray nozzle for dampening the washing	قُوَّةُ الرَزَّازِ لَتَرْطِيبِ الْعَسِيلِ
14 steam hole (steam slit)	فَمَّخَةٌ خُرُوجِ الْبَخَارِ
15 ironing table	مَطاوِلَةُ الْكَبِّيِّ
16 ironing board (ironing surface)	سَطْحُ الْكَبِّيِّ
17 ironing-board cover	غَطَاءُ سَطْحِ الْكَبِّيِّ
18 iron well	حَاوِيَةٌ الْمِكْوَاةِ، بَثْرُ الْمِكْوَاةِ
19 aluminium (Am. aluminium) frame	إِطَارٌ مِنَ الْأَلومِينِيُومِ
20 sleeve board	لَوْحَةٌ كَبِّيِّ الْأَحْكَامِ
21 linen bin	وَعَاءُ الْغَسِيلِ
22 dirty linen	غَسِيلٌ مُتَمَسِّخٌ
23-34 washing machines and driers	الغسالات الكهربائية والمخففات
23 automatic washing machine	غَسَالَةٌ آليَّةٌ
24 washing drum	أَسْطِوانَةُ الْغَسَالَةِ
25 safety latch (safety catch)	مَرْدَاجٌ تَنْبِيْتُهِ لِلأَمَانِ
26 program selector control	فَرَصُ التَّحَكُّمِ فِي اخْتِيَارِ البرنامِجِ
27 front soap dispenser [with several compartments]	مُوزَعٌ صَابُونِ أَمَامِي [مَتَعَدِّدِ الْحِجْرَاتِ]
28 tumble drier	مُخَفِّفٌ دَوَّارٌ
29 drum	أَسْطِوانَةٌ، بِرَمِيلٌ
30 front door with ventilation slits	بَابٌ أَمَامِي ذُو فَتَحَاتٍ تَهْوِيَّةِ
31 worktop	سَطْحُ الشُّغْلِ
32 ailer	مَتَشِّرٌ غَسِيلِ
33 clothes line (washing line)	حَبْلٌ شَرُّ الْغَسِيلِ
34 extending ailer	مَتَشِّرٌ غَسِيلِ اِمْتِدَادِي
35 stepladder (steps), an aluminium (Am. aluminium) ladder	سَلْمٌ نَقَالِي

faucet) for hot and cold water	وَالْبَارِدِ
3 foam bath (bubble bath)	حَمَّامٌ فُقَاعَاتِ
4 toy duck	بِلَّةٌ لَعْبَةٌ
5 bath salts	أَمْلَاحُ الْحَمَّامِ
6 bath sponge (sponge)	اسْفنجِيَّةُ الْحَمَّامِ
7 bidet	مَشْفِطَةٌ
8 towel rail	حَاوِيَةُ الْمَشْفِطَةِ/ الْعُوطَةِ
9 terry towel	مَشْفِطَةٌ وَبَرِيَّةٌ
10 toilet roll holder (Am. bathroom tissue holder)	حَامِلُ وِرْقِ الْحَمَّامِ
11 toilet paper (coll. loo paper, Am. bathroom tissue)	وِرْقٌ حَمَّامِ
12 toilet (lavatory, W.C., coll. loo)	دَوْرَةُ الْمِيَاهِ (مَرْحَاضٌ)
13 toilet pan (toilet bowl)	سَلْمَانِيَّةُ الْمَرْحَاضِ
14 toilet lid with terry cover	غَطَاءُ مَرْحَاضِ مَرُودٍ بَغَطَاءٍ وَبَرِيٍّ
15 toilet seat	مَقْعِدُ الْمَرْحَاضِ
16 cistern	صَنْدُوقُ الطَّرْدِ
17 flushing lever	ذِرَاعٌ تَشْوِيقِ صَنْدُوقِ الطَّرْدِ
18 pedestal mat	فُرْشَةٌ الْقَاعِيَّةِ
19 tile	بِلَاطَةٌ
20 ventilator (extraction vent)	فِتْحَةٌ تَهْوِيَّةٌ
21 soap dish	وَعَاءُ الصَّابُونَةِ (صَبَانَةٌ)
22 soap	صَابُونَةٌ
23 hand towel	مَشْفِطَةٌ يَدٌ
24 washbasin	حَوْضٌ غَسِيلِ الْأَيْدِي
25 overflow	فِتْحَةٌ تَصْرِيفِ الْمِيَاهِ الْفَائِضَةِ
26 hot and cold water tap	صَنْبُورٌ مَاءِ سَاخِنٍ وَبَارِدٍ
27 washbasin pedestal with trap (anti-syphon trap)	قَاعَةٌ حَوْضِ الْغَسِيلِ مَزُودَةٌ بِمَجْبِسِ
28 tooth glass (tooth mug)	كُوبٌ غَسِيلِ الْأَسْنَانِ
29 electric toothbrush	فُرْشَاةٌ أَسْنَانِ كَهْرَبَائِيَّةٌ
30 detachable brush heads	رُؤُوسُ فُرْشَاةٍ قَابِلَةٌ لِلْفِصْلِ
31 mirrored bathroom cabinet	خِزانة حَمَّامِ مَرُودَةٌ بِمِرَاةٍ
32 fluorescent lamp	لَمْبَةٌ فُلُورِسْتِ
33 mirror	مِرَاةٌ
34 drawer	دَرَجٌ
35 powder box	عَلْبَةٌ الْبُودَرَةِ
36 mouthwash	غَسُولٌ لِقَمِّ
37 electric shaver	مَاكِينَةٌ حَلَاقَةِ كَهْرَبَائِيَّةِ
38 aftershave lotion	غَسُولٌ بَعْدَ الْحَلَاقَةِ
39 shower cubicle	خِجْرَتَةُ الدُّشِ
40 shower curtain	سِتَارَةُ الدُّشِ
41 adjustable shower head	رَأْسُ دَشٍّ قَابِلَةٌ لِلتَّعْدِيلِ
42 shower nozzle	قُوَّةُ الدُّشِ
43 shower adjustment rail	قَضِيبٌ تَعْدِيلِ ارْتِفَاعِ الدُّشِ
44 shower base	قَاعَةٌ خِجْرَتَةِ الدُّشِ
45 waste pipe	مَاسُورَةٌ تَصْرِيفِ
46 bathroom mule	خَفٌّ/شَيْبِنِبِ الْحَمَّامِ
47 bathroom scales	مِيزَانُ حَمَّامِ
48 bath mat	فُرْشَةٌ حَمَّامِ

41 large soft toy dog	لَعْبَةٌ طَرِيَّةٌ عَلَى شَكْلِ كَلْبٍ كَبِيرِ
42 dice cup	كَأْسُ الذَّرْدِ
48 Kindergarten (Day Nursery)	رُوضَةٌ الْأَطْفَالِ (الْحَضْرَاتُ النَّهَارِيَّةِ)
1-20 pre-school education (nursery education)	التَّعْلِيمُ قَبْلَ بُلُوغِ سِنِ الْمَعْتَرِسَةِ (مَرِحَلَةُ الرُّوضَةِ)
1 nursery teacher	مُدْرِسَةٌ الرُّوضَةِ
2 nursery child	طِفْلٌ الرُّوضَةِ
3 handicraft	شُعْلٌ يَدَوِيٌّ
4 glue	صَمْعٌ، غِرَاءٌ
5 watercolour (Am. watercolor) painting	رَسْمٌ بِالْوَانِ مَائِيَّةٌ
6 paintbox	صَنْدُوقُ الْأَلْوَانِ
7 paintbrush	فُرْشَاةٌ الْأَلْوَانِ
8 glass of water	كُوبٌ مَاءٍ
9 jigsaw puzzle (puzzle)	أَحْجِيَّةُ الصُّورِ الْمُقَطَّوعَةِ
10 jigsaw puzzle piece	قِطْعَةٌ مِنَ أَحْجِيَّةِ الصُّورِ الْمُقَطَّوعَةِ
11 coloured (Am. colored) pencils (wax crayons)	أَقْلَامٌ مَلَوْنَةٌ
12 modelling (Am. modelling) clay (Plasticine)	صَلْصَالٌ
13 clay figures (Plasticine figures)	مُجَسِّمَاتٌ/أَشْكَالٌ صَلْصَالِيَّةٌ
14 modelling (Am. modeling) board	لَوْحَةٌ صَنَعِ الْمُجَسِّمَاتِ الصَّلْصَالِيَّةِ
15 chalk (blackboard chalk)	طَبَاشِيرٌ (طَبَاشِيرُ السُّبُورَةِ)
16 blackboard	سَبُورَةٌ
17 counting blocks	مَكْعَبَاتٌ تَعْلِيمِ الْعَدِّ
18 felt pen (felt tip pen)	قَلَمٌ طَرَفُهُ لَبَازِي
19 shapes game	لَعْبَةُ الْأَشْكَالِ
20 group of players	مَجْمُوعَةٌ مِنَ اللَّاعِبِينَ
21-32 toys	لَعِبٌ
21 building and filling cubes	مَكْعَبَاتُ الْبِنَاءِ وَالصَّنْوِ
22 construction set	مَطَاقِمُ تَرْكِيبِ
23 children's books	كُتُبٌ أَطْفَالِ
24 doll's pram, a wicker pram	عَرَبِيَّةٌ الْأُمَمِيَّةِ
25 baby doll	دُمِيَّةٌ عَلَى شَكْلِ طِفْلِ رَضِيعِ
26 canopy	غَطَاءٌ، مَحْطَلَةٌ
27 building bricks (building blocks)	مَكْعَبَاتُ الْبِنَاءِ
28 wooden model building	نَمُودَجٌ مَبْنِيٌّ خَشْبِيٌّ
29 wooden train set	مَطَاقِمُ قَطَارٍ خَشْبِيٍّ
30 rocking teddy bear	دُبٌّ هَزَّازٌ
31 doll's pushchair	كُرْسِيٌّ دُمِيَّةٌ يَدْفَعُ لِأَمَامِ
32 fashion doll	دُمِيَّةٌ أَرِيَاءٌ
33 child of nursery school age	طِفْلٌ فِي سِنِ الرُّوضَةِ
34 cloakroom	غُرْفَةٌ الْعِيَاءَاتِ وَالْمَعَاظِفِ
49 Bathroom and Toilet	الْحَمَّامُ وَنُورَةُ الْمِيَاهِ
1 bath	حَوْضُ الْاسْتِحْضَامِ (الْبَانِيُو)
2 mixer tap (Am. mixing)	صَنْبُورٌ خِلَاطٌ لِلْمَاءِ السَّاخِنِ

cleaner (wet and dry vacuum cleaner)	الأغراض (مكشّسة كهربائية للكشّ والتمشّح)
81 castor	دولاب (عجلة) صغير
82 motor unit	وحدة المحرك (الموتور)
83 lid clip	مشبك الغطاء
84 coarse dirt hose	خراطوم شفط القاذورات الضخمة
85 special accessory (special attachment) for coarse dirt	وصلة خاصة للقاذورات الخشنة
86 dust container	حاوية التراب
87 shopper (shopping trolley)	تروولي متحرك

51 Flower Garden

1-35 flower garden	حديقة الأزهار
1 pergola	حديقة الأزهار
2 deck-chair	ظلة نفقبة، تمريشة
3 lawn rake (wire-tooth rake)	كروسي قماش قابل للطي مشط العشب، مبدنة
4 garden rake	مشط الحديقة
5 Virginia creeper (American ivy, wood-bine), a climbing plant (climber, creeper)	لبلاية عدّاء، كرمة، نبات متسلق
6 rockery (rock garden)	حديقة صخرية
7 rock plants; varieties: stonecrop (wall pepper), houseleek, dryas, aubretia	نباتات الرّدة، أنواعها سيديم (سيديم حريف) مخلطة، أبرياسية
8 pampas grass	وزينية الميباس
9 garden hedge	سياج الحديقة
10 blue spruce	رايتجية شائكة
11 hydrangeas	هدرنجيات
12 oak (oak tree)	بلوط (شجرة بلوط)
13 birch (birch tree)	بتولا (شجرة القصبان)
14 garden path	ممر الحديقة
15 edging	حافة
16 garden pond	بركة الحديقة
17 flagstone (stone slab)	بلاطة حجرية
18 water lily	زنبق الماء، نيلوفر
19 tuberous begonias	بغونية عشقوية
20 dahlias	أضاليا
21 watering can (Am. sprinkling can)	مرشحة السقي
22 weeding hoe	معرق تشيب
23 lupin	ترمس
24 marguerites (oxeye daisies, white oxeye daisies)	لؤلوية، مرغرينا
25 standard rose	وردة عادية
26 gerbera	جربارة
27 iris	سوسن
28 gladioli	سيف الغراب، دلبوث
29 chrysanthemums	أقحوان
30 poppy	خشخاش
31 blazing star	النجم المتوهج
32 snapdragon (antirrhinum)	أنف العجل، زهرة الخطم

33 lawn	مرج
34 dandelion	طرخشقون
35 sunflower	عباد/دوار الشمس

52 Fruit and Vegetable Garden

1-32 allotment (fruit and vegetable garden)	بستان الفواكه والخضروات
1, 2, 16, 17, 29 dwarf fruit trees (espaliers, espalier fruit trees)	بستان الفواكه والخضروات أشجار فواكه قزمية
1 quadruple cordon, a wall espalier	شجرة مقلّمة رباعياً
2 vertical cordon	شجرة مقلّمة عمودياً
3 tool shed (garden shed)	كشك الأدوات/الحديقة
4 water butt (water barrel)	برميل ماء
5 climbing plant (climber, creeper, rambler)	نبات متسلق (نبات زاحف)
6 compost heap	كومة من السماد العضوي
7 sunflower	عباد الشمس
8 garden ladder (ladder)	سلم نقالي الحديقة (سلم)
9 perennial (flowering perennial)	نبته معمرة
10 garden fence (paling fence, paling)	سياج الحديقة
11 standard berry tree	شجرة عنبية عادية
12 climbing rose (rambling rose) on the trellis arch	وردة متسلقة على قوس معترس شبيكي
13 bush rose (standard rose tree)	شجرة ورد عادية
14 summerhouse (garden house)	استراحة الحديقة
15 Chinese lantern (paper lantern)	فانوس من الورق
16 pyramid tree (pyramidal tree, pyramid), a free-standing espalier	شجرة هرمية، مسندة حرّة النمو
17 double horizontal cordon	شجرة مزدوجة مقلّمة أفقياً
18 flower bed, a border	زهراء، حد
19 berry bush (gooseberry bush, currant bush)	شجيرة عنبية (كشمش شاك)
20 concrete edging	حافة خرسانية
21 standard rose (standard rose tree)	وردة عادية (شجرة ورد عادية)
22 border with perennials	حاشية ذات نبات معمّر
23 garden path	ممر الحديقة
24 allotment holder	مالك (أو مستأجر) الحديقة
25 asparagus patch (asparagus bed)	زهراء/خوض الهليون
26 vegetable patch (vegetable plot)	رقعة زراعة الخضروات
27 scarecrow	خيال المأتم، نطار
28 runner bean (Am. scarlet runner), a bean plant on poles (bean poles)	فاصولية إسبانية، نبات الفاصوليا على أعمدة

بستان الفواكه والخضروات

29 horizontal cordon	شجرة مقلّمة أفقياً
30 standard fruit tree	شجرة فواكه عادية
31 tree stake	ود تثبيت الشجرة
32 hedge	سياج

53 Indoor Plants (Houseplants)

1 pelargonium (crane's bill), a geranium	زهرة الآلام، نبات متسلق (نبات زاحف)
2 passion flower (Passiflora), a climbing plant (climber, creeper)	قوشية
3 fuchsia, an anagraceous plant	طرطور الباشا
4 nasturtium (Indian cress, tropaeolum)	كف مرّيم، عشب من الرّبعيات
5 cyclamen, a primula-aceous herb	بطونية، تبغية
6 petunia, a solanaceous herb	غلكسيّة، نبات من الجسغوريات
7 gloxinia (Sinningia), a gesneriaceae plant	كليفية أرجوانية
8 Clivia minata, an amaryllis (narcissus)	قند أفريقي، نبات زينفوني
9 African hemp (Sparmannia), a tiliaceae plant, a linden plant	بغونية
10 begonia	أس
11 myrtle (common myrtle, Myrtus)	أزالية، صحراوية، نبات حنجي
12 azalea, an ericaceous plant	الأوة، نبات زنبقي
13 aloe, a liliaceous plant	قنقدية، شوك الجمال
14 globe thistle (Echinops)	إستبيلة، نبات من الصقلابيات
15 stapelia (carrion flower), an asclepiada-ceous plant	صنوبر جزيرة نورفوك (أروكارية تزرع كنبات زينة)
16 Norfolk Island Pine (an araucaria grown as an ornamental)	خولنجان، نبات من الفمسية السعدية
17 galingale, a cyperaceous plant of the sedge family	

54 Propagation of Plants

1 seed sowing (sowing)	بذر البذور
2 seed pan	خوض البذور
3 seed	بذور
4 label	بطاقة تحريف
5 pricking out (pricking off, transplanting)	نقل النباتات
6 seedling (seedling plant)	بادرة، شتلة/غرس لم تنقل
7 dibber (dibble)	مغرس
8 flower pot (pot)	إصيص زهور
9 sheet of glass	لوح من الزجاج
10 propagation by	التكاثر بالتقويم مع التجوز.

طبائات داخلية (نباتات المسكن)

layering	التكاثر بالعكس
11 layer	عكس، ترقيدة
12 layer with roots	ترقيدة ذات جذور
13 forked stick used for fastening	عصا مشعبة تستخدم للتثبيت
14 propagation by runners	التكاثر بالمادّ بالرند
15 parent (parent plant)	النبات الأصل/المصدر
16 runner	رند، مداد
17 small rooted leaf cluster	عشود ورقة صغير ذو جذور
18 setting in pots	الوضع في أصيص
19 cutting in water	فصل في الماء
20 cutting (slip, set)	فصل (قلم، ود)
21 root	جذر
22 bud cutting on vine tendril	قلم بزعم معلقة في الكرّم
23 scion bud, ■ bud	بزعم تطعيم، بزعم
24 sprouting (shooting)	فصل ركزة
25 stem cutting (hardwood cutting)	فصل بالساق
26 bud	بزعم
27 propagation by bulbils (brood bud bulblets)	التكاثر بالمصليات
28 old bulb	وصلة كاملة النمو
29 bulbil (brood bud bulblet)	بمصيلة
30-39 grafting (graftage)	التطعيم
30 budding; here: shield budding)	تطعيم بالزعم، هنا بزعمة باستخدام طعم يكون جزءاً صغيراً من الساق
31 budding knife	سكين التطعيم
32 T-cut	فصل تائي
33 support (stock, root-stock)	ساق سائدة (فسيلة جذرية)
34 inserted scion bud	بزعم تطعيم مغروس
35 raffia layer (bast layer)	ترقيدة رافية
36 side grafting	تطعيم جانبي
37 scion (shoot)	عصن التطعيم (رشد، فرخ)
38 wedge-shaped notch	بقرة اسفينية الشكل
39 splice grafting	تطعيم إنجليزي/تراكي

55 Market Garden (Am. Truck Garden, Truck Farm)

1-51 market garden (Am. truck garden, truck farm)	مزرعة الخضروات
1 tool shed	كشك الأدوات
2 water tower (water tank)	برج تخزين الماء
3 market garden (Am. truck garden, truck farm), a tree nursery	مزرعة الخضروات (مشكل)
4 hothouse (forcing house, warm house)	دفيئة حارة (بناء البواكير)
5 glass roof	سقف زجاجي
6 [roll of] matting (straw	بورية (حصيرة من القصب

matting, reed matting, shading)	أو سوق السُّلت (thene greenhouse)
7 boiler room (boiler house)	غُرْفَة المِرْجَل (41 ventilation flap)
8 heating pipe (pressure pipe)	أَنْبُوب التسخين (أنبوب الضغط)
9 shading panel (shutter)	لَوْح تظليل
10-11 ventilators (vents)	فَنَحات تَهْوِيَة
10 ventilation window (window vent, hinged ventilator)	نَافِذَة تَهْوِيَة
11 ridge vent	الفَنَحة العُلْوِيَة
12 potting table (potting bench)	مَعدِن التَاصِيص
13 riddle (sieve, garden sieve, upright sieve)	عُرْبَال (عُرْبَال الحديديّة/ قائم)
14 garden shovel (shovel)	مِجْرَفَة الحديديّة، جَارُوف
15 heap of earth (composted earth, prepared earth, garden mould, Am. mold)	كُومَة تَراب (تراب مَفرُوج بيسماد عضوي)
16 hotbed (forcing bed, heated frame)	مِدْفَاعَة (دَفِيعة البَوَاكِر)
17 hotbed vent (frame vent)	فَنَحة المِدْفَاعَة
18 vent prop	سِنَاد فَنَحة المِدْفَاعَة
19 sprinkler (sprinkling device)	رَشاش (جهاز الرش)
20 gardener (nursery gardener, grower, commercial grower)	البِستَاني، الجَنائِثي
21 cultivator (hand cultivator, grubber)	مِسْلَفَة، آلَة الحِرائَة
22 plank	لَوْح خَشَب ثَخِين
23 pricked-out seedlings (pricked-off seedlings)	شَتلات مَعقُولَة
24 forced flowers [forcing]	زَهور مَعزُوسَة [زِرائَعَة البَوَاكِر]
25 potted plants (plants in pots, pot plants)	نباتات مَوْصُصَة
26 watering can (Am. sprinkling can)	مِرْشَة السَقْي
27 handle	مِقْبَض
28 rose	فُوّهَة المِرْشَة
29 water tank	خُوض مَاء
30 water pipe	مَاسُورَة المَاء
31 bale of peat	بَالَة طُرب
32 warm house (heated greenhouse)	صُنُوبَة دافئة
33 cold house (unheated greenhouse)	صُنُوبَة باردة
34 wind generator	مَوْدَع يَعْمَل بِطَاقَة الرِّياح
35 wind wheel	مِرْوَحة دَوّارة الرِّياح
36 wind vane	رِيشَة المِرْوَحة
37 shrub bed, a flower bed	زَهْرَاء شَجِيرات/ زهور
38 hoop edging	حافَة طُوقِيَة
39 vegetable plot	قِطْعَة أَرْض لِزِرائَعَة الخِضروات
40 plastic tunnel (poly-	نَفق بِلَاسْتِيكي (صُوبَة من

41 ventilation flap	غِلاَة تَهْوِيَة
42 central path	مَمَر مَركَزِي
43 vegetable crate	صَنَدُوق الخِضروات
44 tomato plant	نبات التَمبُورَة/ الطَمَاطِم
45 nursery hand	عَامِل المَنشَل
46 nursery hand	عَامِلَة المَنشَل
47 tub plant	نبات مَزرُوع في بَرَمِيل
48 tub	بَرَمِيل
49 orange tree	شَجَرَة برَيقال
50 wire basket	سَلَة سَلَكِيَة
51 seedling box	صَنَدُوق الشَتلات

56 Garden Tools	أدوات الحديديّة
1 dibber (dibble)	مَغرَس
2 spade	جَارُوف، مَجراف
3 lawn rake (wire-tooth rake)	مَنشَل العُشب
4 rake	مَنشَل الحِدايق، قِشاشَة
5 ridging hoc	مِغزَق، مِغول حَرَت الجِديرات

6 trowel	مَسطَرين
7 combined hoe and fork	مِغزَق وشوكة
8 sickle	مَنجَلَة، شُرْشُرَة
9 gardener's knife (pruning knife, billhook)	سِكِين البِستَاني (مَقْبَض، مِجْطَب)
10 asparagus cutter (asparagus knife)	سِكِين الِهلِيُون

11 tree pruner (long-handled pruner)	مِقْص تَقْلِيم/ تَشْدِيب الشَّجَر
12 semi-automatic spade cultivator	جَارُوف شِبْه آلي
13 three-pronged cultivator	مِسْلَفَة ثَلاثِيَة الشَّعب
14 tree scraper (bark scraper)	مِكَشَطَة لِحاء الشَّجَر
15 lawn aerator (aerator)	أداة تَهْوِيَة العُشب
16 pruning saw (saw for cutting branches)	مِنشار تَشْدِيب

17 battery-operated hedge trimmer	مِقْص لِتَشْدِيب السَّيَاح يَعْمَل بِالْبَاطَرِيَة
18 motor cultivator	مِسْلَفَة بِمَحْرَك
19 electric drill	بِذارة كَهْرَبائيَة
20 gear	صَنَدُوق التَرُوس
21 cultivator attachment	مُحَوِّق المِسْلَفَة
22 fruit picker	أداة قَلْف الفاكهَة
23 tree brush (bark brush)	فُرْشاة اللِحاء
24 sprayer for pest control	رَشاش مَكاَفَحة الأَفات
25 lance	مِزْرَاق
26 hose reel (reel and carrying cart)	بِكرَة الخُرطوم (بِكرَة و عَرَبِيَة الحَمَل)
27 garden hose	خُرطوم الحديديّة
28 motor lawn mower (motor mower)	جَزارة مَرُوج بِمَحْرَك

29 grassbox	صَنَدُوق تَجْمِيع العُشب
30 two-stroke motor	مَحْرَك ثَنايِي الأَشْواط
31 electric lawn mower (electric mower)	جَزارة مَرُوج كَهْرَبائيَة
32 electric lead (electric cable)	سَلَك تَوَصِيل كَهْرَبائي (كَبيل كَهْرَبائي)

33 cutting unit	وَحْدَة القَطْع
34 hand mower	جَزارة تَهْوِيَة
35 cutting cylinder	أَسطوانَة القَطْع
36 blade	سِلاح الجَزارة
37 riding mower	جَزارة مَرَكَبِيَة
38 brake lock	مِزْلاج الفَرَمَلَة
39 electric starter	أَلِيَة بَدَأ التَشغِيل الكَهْرَبائيَة
40 brake pedal	دَواسَة الفَرَمَلَة
41 cutting unit	وَحْدَة القَطْع
42 tip-up trailer	مَقْطُورَة بِحافَة مَرْتَعَة
43 revolving sprinkler, a lawn sprinkler	آلَة رَش دَوّارة، رَشاشَة العُشب
44 revolving nozzle	فُوّهَة دَوّارة
45 hose connector	وَصَلَة الخُرطوم
46 oscillating sprinkler	آلَة رَش مَرْتَجِحَة
47 wheelbarrow	عَرَبِيَة يدويَة بِدَوَلايِن
48 grass shears	مِقْص العُشب
49 hedge shears	مِقْص السَّيَاح
50 secateurs (pruning shears)	مِقْص تَقْلِيم و تَشْدِيب

57 Vegetables (Vegetable Plants)	الخِضْرَوَات (نباتات الخِضَر)
1-11 leguminous plants (Leguminosae)	الْقَرْنِيَّات، القِطْنايَّات

1 pea, a plant with a papilionaceous corolla	بَسَلَة، نَبات ذُو تَوَيْج فِراشي
2 pea flower	زَهْرَة البَسَلَة
3 pinna leaf	وَرَقَة رِيشِيَة
4 pea tendril, a leaf tendril	حائِق/ عِظْفَة سَلِيَة
5 stipule	أُذُنَة، رِئْمَة
6 legume (pod), a seed vessel (pericarp, legume)	قَرْن (عِلاف التَمْرَة)

7 pea [seed]	[جَبَة] البَسَلَة
8 bean plant (bean), a climbing plant (climber, creeper); varieties: broad bean (runner bean, Am. scarlet runner), climbing bean (climber, pole bean), scarlet runner bean; smaller: dwarf French bean (bush bean)	نبات البَوَل/ الفاصوليا (نبات مَنسَلِق/ زاجِف) باقِلاء، باقِلاء مَنسَلَقَة، أنواعها فاصوليا اسبانيّة-الأصغر حجماً فاصوليا قَرْمِيَة

9 bean flower	زَهْرَة البَوَل
10 twining beanstalk	ساق بَوَل مَلقَنَة
11 bean [pod with seeds]	نبات الفاصوليا [قَرْن به الحبوب]

12 tomato	الطَمَاطِم، البَنَدُورَة
13 cucumber	الخِيار
14 asparagus	هَلِيُون، هَلِيُون
15 radish	الفِجَل
16 white radish	الفِجَل الأَبْيَض
17 carrot	الجَزَر
18 stump-rooted carrot	جَزَر الأَرُومَة
19 parsley	المَقْدُونِس
20 horse-radish	الفِجَل البَرِّي
21 leeks	الكَرَّاث

22 chives	النَّوم المَعْمَر
23 pumpkin (Am. squash); sim.: melon	الكُوسِي، القُرْع
24 onion	البِصل
25 onion skin	قَشْرَة البِصلَة
26 kohlrabi	الكَرْبُ السَّاقِي، أبو رِجَبَة
27 celery	كَرْفَس لَفْتِي
28-34 brassicas (leaf vegetables)	الوَرَقِيَّات

28 chard (Swiss chard, seakale beet)	سَلَق
29 spinach	اسفاناخ
30 Brussels sprouts (sprouts)	كُرْبُ بَرُوكسل
31 cauliflower	قَمِيْط
32 cabbage (round cabbage, head of cabbage), a brassica: cultivated races (cultivars): green cabbage, red cabbage	كُرْبُ، مَلْفُوف (كُرْبُ سَمْدِير، رَأْس من الكُرْبُ) - أنواعه المَزرُوعَة كُرْبُ أخْضَر، كُرْبُ أحْمَر
33 savoy (savoy cabbage)	كُرْبُ ساقُوي
34 kale (curly kale, kail), a winter green	كُرْبُ لارُويسي

35 scorzonera (black salsify)	فُومي أسود، قِبارُون
36-40 salad plants	نباتات السَلْطَة
36 lettuce (cabbage lettuce, head of lettuce)	الخِص (رَأْس من الخِص)
37 lettuce leaf	وَرَقَة الخِص
38 corn salad (lamb's lettuce)	خِص النَجْعَة

39 endive (endive leaves)	هَنْدِبا، لَعاعَة
40 chicory (succory, salad chicory)	هَنْدِبا بَرِيَة
41 globe artichoke	جِرْشَف، كَلْكَز
42 sweet pepper (Spanish paprika)	قَلْفَل حلو(طليغلة دغليّة)

58 Soft Fruit and Pomes	الفاكهة الطرية والتفاحيات
1-30 soft fruit (berry bushes)	الفاكهة الطرية

1-15 Ribes	الكِشْمِش
1 gooseberry bush	الكِشْمِش السَّاك
2 flowering gooseberry cane	فَرَع كِشْمِش مَزهَر
3 leaf	وَرَقَة
4 flower	زَهْرَة
5 magpie moth larva	بِرْقاَنَة أُرْثِيَة الكِشْمِش
6 gooseberry flower	زَهْرَة الكِشْمِش
7 epigynous ovary	مِبيص عُلوي
8 calyx (sepals)	الكَاس (كَاسِيَّات)
9 gooseberry, a berry	تَمْرَة الكِشْمِش
10 currant bush	كِشْمِش
11 cluster of berries	عَنقود عِنبِي
12 currant	كِشْمِش
13 stalk	ساق
14 flowering cane of the currant	فَرَع مَزهَر من الكِشْمِش

15 raceme	عقود	55 withered flower	زهرة ذابلة	23 plum stone	نواة الأجاجس	lily), a narcissus	نرجس الشعراء
16 strawberry plant; varieties: wild strawberry (woodland strawberry), garden strawberry, alpine strawberry	نبات الفراولة، أنواع الفراولة البرية، فراولة البساتين، فراولة البنية	56 apple [longitudinal section]	شجرة التفاح [مقطع طولى]	24 greengage	مربوق أخضر	4 poet's narcissus (pheasant's eye, poet's daffodil); sim.: polyanthus narcissus	
17 flowering and fruit-bearing plant	نبات مزهر ومثمر	57 apple skin	قشرة الشجرة	25 mirabelle (transparent gage), a plum	ميرابيلة	5 bleeding heart (lyre flower), a fumariaceous flower	مهمازية رابطة، زهرة من الشاهترجيات
18 rhizome	جذمور، جذمار	58 flesh (pulp)	لحم الفرة	26-32 peach tree	شجرة الخوخ	6 sweet william (bunch pink), a carnation	فرغفل ملتحم، فرغفل شائع
19 ternate leaf (trifoliate leaf)	ورقة ثلاثية	59 core (apple core, carpels)	لباب (أخنية)	26 fruiting branch (branch in blossom)	فرع مزهر	7 gillyflower (gilliflower, clove pink, clove carnation)	منتور شتوي (فرغفل شائع)
20 runner (prostrate stem)	رشد، مداد	60 apple pip, a fruit pip	حبة التفاح	27 peach flower (peach blossom)	زهرة الخوخ (نورة)	8 yellow flag (yellow water flag, yellow iris), an iris	سوسن أصفر، سوسن
21 strawberry, a pseudo-carp	شجرة الفراولة، شجرة كاذبة	61 apple stalk (stalk)	ساق شجرة التفاح (ساق)	28 flower shoot	نبته الزهرة	9 tuberose	سنبك الروم
22 epicalyx	كأس الزهرة الخارجي، كؤيس فوقي	62 codling moth (codlin moth)	دودة التفاح	29 young leaf (sprouting leaf)	ورقة نابته	10 columbine (aquilegia)	أقنولية (أخضوية)
23 achene (seed)	فقيرة	63 burrow (tunnel)	جحر	30 fruiting branch	فرع مثمر	11 gladiolus (sword lily)	دليوث، سيف الغراب
24 flesh (pulp)	لحم الشجرة	64 larva (grub, caterpillar) of a small moth	يرقانة دودة صغيرة	31 peach	شجرة الخوخ	12 Madonna lily (Annunciation lily, Lent lily), a lily	ذئبق أبيض (سوسن أبيض)
25 raspberry bush	توت العليق	65 wormhole	ثقب دودة، نخروب	32 peach leaf	شجيرة المشمش	33 flowering apricot branch (apricot branch in blossom)	زهرة المشمش
26 raspberry flower	زهرة توت العليق	59 Drupes and Nuts	الجوز والنويات	33-36 apricot tree	شجرة المشمش	34 apricot flower (apricot blossom)	زهرة المشمش
27 flower bud (bud)	برعم زهرة (برعم)	1-36 drupes (drupaceous plants)	الجوز والنويات	35 apricot	شجرة الكرز/ القراصيا	35 apricot	شجرة الكرز
28 fruit (raspberry), an aggregate fruit (compound fruit)	شجرة توت العليق، شجرة علقية	1-18 cherry tree	شجرة الكرز/ القراصيا	36 apricot leaf	شجرة الكرز	36 apricot leaf	ورقة الكرز
29 blackberry	توت شوكي	1 flowering branch of the cherry tree (branch of the cherry tree in blossom)	شجرة الكرز/ القراصيا	37-51 nuts	شجرة الجوز	37-43 walnut tree	شجرة الجوز
30 thorny tendril	خالق شوكي	2 cherry leaf	ورقة الكرز	37 flowering branch of the walnut tree	شجرة الجوز	37 flowering branch of the walnut tree	فرع مزهر من شجرة الجوز
31-61 pomiferous plants	المفطاحيات	3 cherry flower (cherry blossom)	زهرة الكرز	38 female flower	زهرة أنثى	38 female flower	زهرة أنثى
31 pear tree; wild: wild pear tree	شجرة الكثرى، شجرة الكثرى البرية	4 peduncle (pedicel, flower stalk)	عقود، زند	39 male inflorescence (male flowers, catkins with stamens)	شكل ازدهار ذكري (زهور ذكري، قبة ذات أسدية)	39 male inflorescence (male flowers, catkins with stamens)	شكل ازدهار ذكري (زهور ذكري، قبة ذات أسدية)
32 flowering branch of the pear tree	فرع مزهر من شجرة الكثرى	5 cherry; varieties: sweet cherry (heart cherry), wild cherry (bird cherry), sour cherry, morello cherry (morello)	شجرة الكرز، أنواعها الكرز الحلو (قراصيا)، الكرز البري، الكرز الحامض	40 alternate pinnate leaf	ورقة ريشية متعاقبة	40 alternate pinnate leaf	ورقة ريشية متعاقبة
33 pear [longitudinal section]	شجرة الكثرى [مقطع طولى]	6-8 cherry (cherry fruit) [cross section]	ثمرة الكرز [مقطع عرضي]	41 walnut, a drupe (stone fruit)	شجرة الجوز (نوية)	41 walnut, a drupe (stone fruit)	شجرة الجوز (نوية)
34 pear stalk (stalk)	ساق الكثرى (ساق)	6 flesh (pulp)	لحم الثمرة (لب)	42 soft shell (cupule)	غلاف طري (جمع)	42 soft shell (cupule)	غلاف طري (جمع)
35 flesh (pulp)	لحم الثمرة (لب)	7 cherry stone	نواة الكرز	43 walnut, a drupe (stone fruit)	شجرة الجوز (نوية)	43 walnut, a drupe (stone fruit)	شجرة الجوز (نوية)
36 core (carpels)	الل (أخنية)	8 seed	حبة الثمرة	44-51 hazel tree (hazel bush), an anemophilous shrub (a wind-pollinating shrub)	شجرة البندق، نبات ويحي الإلحاق	44-51 hazel tree (hazel bush), an anemophilous shrub (a wind-pollinating shrub)	شجرة البندق، نبات ويحي الإلحاق
37 pear pip (seed), a fruit pip	حبة الكثرى (بذرة فاكهة)	9 flower (blossom) [cross section]	زهرة (نورة) [مقطع عرضي]	44 flowering hazel branch	فرع بندق مزهر	44 flowering hazel branch	فرع بندق مزهر
38 pear blossom	نورة الكثرى	10 stamen	سداة	45 male catkin	قبة ذكر	45 male catkin	قبة ذكر
39 ovules	بذريات	11 petal	بتلة	46 female inflorescence	شكل ازدهار أنثى	46 female inflorescence	شكل ازدهار أنثى
40 ovary	مبيض	12 sepal	فصلية، كأسية	47 leaf bud	برعم الورقة	47 leaf bud	برعم الورقة
41 stigma	ميسم	13 pistil	مدقة	48 fruit-bearing branch	فرع مثمر	48 fruit-bearing branch	فرع مثمر
42 style	حامل الميسم	14 ovule enclosed in perigynous ovary	بذيرة داخل مبيض محيطي	49 hazelnut (hazel, cobnut, cob), a drupe (stone fruit)	شجرة البندق (نوية)	49 hazelnut (hazel, cobnut, cob), a drupe (stone fruit)	شجرة البندق (نوية)
43 petal	بتلة، توجية	15 style	ميسم	50 involucre (husk)	قناب (قشرة)	50 involucre (husk)	قناب (قشرة)
44 sepal	فصلية، كأسية	16 stigma	قلم الميسم	51 hazel leaf	ورقة البندق	51 hazel leaf	ورقة البندق
45 stamen	سداة	17 leaf	ورقة	60 Garden Flowers	ازهار الحدائق	60 Garden Flowers	ازهار الحدائق
46 quince tree	شجرة السفرجل	18 nectary (honey gland)	غدة مفرز الزهرة (غدة عسل)	1 snowdrop (spring snowflake)	زهرة البن الثلجية (البصلة البيضاء الربيعية) بتعيس مثل الألوان	1 snowdrop (spring snowflake)	زهرة البن الثلجية (البصلة البيضاء الربيعية) بتعيس مثل الألوان
47 quince leaf	ورقة السفرجل	19-23 plum tree	الأجاجس	2 garden pansy (heart-sease pansy), a pansy	فرع مثمر	2 garden pansy (heart-sease pansy), a pansy	فرع مثمر
48 stipule	أذن، زمنة	20 oval, black-skinned plum	أجاجس أسود القشرة	3 trumpet narcissus (trumpet daffodil, Lent	ورقة الأجاجس	3 trumpet narcissus (trumpet daffodil, Lent	نرجس كاذب، نرجس بوقي (نرجس)
49 apple-shaped quince [longitudinal section]	سفرجلة على شكل قفاحة [مقطع طولى]	21 plum leaf	ورقة الأجاجس		برعم		
50 pear-shaped quince [longitudinal section]	سفرجلة على شكل كثرى [مقطع طولى]	22 bud	برعم				
51 apple tree; wild: crab apple tree	شجرة التفاح البرية، شجرة التفاح البري						
52 flowering branch of the apple tree	فرع مزهر من شجرة التفاح						
53 leaf	ورقة						
54 apple blossom	نورة التفاح						

9 shepherd's purse	كيس الراعي	11 above-ground silo (fodder silo)	صومعة علف مرتفعة (صومعة علف)
10 flower	زهرة	12 silo pipe (standpipe for filling the silo)	ماسورة الصومعة (ماسورة قائمة لملء الصومعة)
11 fruit (pouch-shaped pod)	ثمرة	13 liquid manure silo	صومعة السماد السائل
12 common groundsel	زهرة الشبخ، شائعة	14 outhouse	بناء إضافي ملحق يستعمل كملتحق أو إسطليل
13 dandelion	طرخشقون	15 machinery shed	عنبر المكن والآلات
14 flower head (capitulum)	رؤيس الزهرة	16 sliding door	باب منزلق
15 infrurescence	عنقود ثمر	17 door to the workshop	باب يؤدي إلى الورشة
16 hedge mustard, a mustard	جرجير، كتأة، خردل	18 three-way tip-cart, a transport vehicle	عربة نقل قلابية
17 stonecrop	سيديوم	19 tipping cylinder	أسطوانة القلب
18 wild mustard (charlock, runch)	خردل بري (خردل الحقول)	20 shafts	أعمدة
19 flower	زهرة	21 manure spreader (fertilizer spreader, manure distributor)	جهاز نثر الأسمدة
20 fruit, a siliqua (pod)	ثمرة خردلية	22 spreader unit (distributor unit)	وحدة النثر
21 wild radish (jointed charlock)	فجل بري	23 spreader cylinder (distributor cylinder)	أسطوانة النثر
22 flower	زهرة	24 movable scraper floor	أرضية مكنطة متحركة
23 fruit (siliqua, pod)	ثمرة (خردلية)	25 side planking (side board)	لوح جانبي
24 common orache (common orach)	سرمق، قطف، إسفاناخ رومي	26 wire mesh front	مقدمة شبكة سلكية
25 goosefoot	رجل الإوز	27 sprinkler cart	عربة رش
26 field bindweed (wild morning glory), a bindweed	لبلاب الحقل	28 sprinkler stand	حامل جهاز الرش (حامل المرشحة)
27 scarlet pimpernel (shepherd's weather-glass, poor man's weatherglass, eye-bright)	حشيشة الحكمة، عشية العلق، أناغابس حقلية	29 sprinkler, a revolving sprinkler	مرشحة، مرشحة دوارة
28 wild barley (wall barley)	شعير بري	30 sprinkler hoses	خرطوم المرشحة
29 wild oat	شوفان/خردال بري	31 farmyard	ساحة المزرعة
30 common couch grass (couch, quack grass, quick grass, scutch grass, twitch grass, witch-grass); sim.: bearded couch grass, sea couch grass	نجيل شائع (نجيل، إبريدة، عكرش)	32 watchdog	كلب حراسة
31 gallant soldier	الجندى النبيل	33 calf	عجل
32 field eryngo (Watling Street thistle), a thistle	قرصعنة الحقول، شوك	34 dairy cow (milk-cow, milker)	بقرة حلب
33 stinging nettle, a nettle	قراص محرق	35 farmyard hedge	سياج ساحة المزرعة
62 Farm Buildings (Am. Farmstead)	مباني المزرعة	36 chicken	ديك
1 house	منزل، دار	37 cock (Am. rooster)	جرار
2 stable	إسطليل	38 tractor	سائق الجرار
3 house cat (cat)	قطعة منزلية	39 tractor driver	مقطورة لجميع الأغراض
4 farmer's wife	زوجة المزارع	40 all-purpose trailer	وحدة بيك أب [مطوية]
5 broom	مقشدة، مكنسة	41 [folded] pick-up attachment	وحدة التقريع
6 farmer	مزارع	42 unloading unit	صومعة مصنوعة من مادة البوليثين، صومعة علف مرعى
7 cowshed	حظيرة الماشية	43 polythene silo, a fodder silo	ماشية ترعى سور مكهرب
8 pigsty (sty, Am. pigpen, hogpen)	زريبة الخنازير	44 meadow	63 Agriculture (Farming)
9 outdoor trough	مغلف خارجي	45 grazing cattle	1-41 work in the fields
10 pig	خنزير	46 electrified fence	1 fallow (fallow field, fallow ground)

4 field	حقل	37 hydraulic bale loader	آلة تحميل بالات آلية
5 swingletree (Am. whiffletree, whipple-tree)	ميزان	38 trailer	مقطورة
6 plough (Am. plow)	محرث	39 manure spreader	ماكينة نثر السماد
7 clod	مذرة، طوبارة	40 four-furrow plough (Am. plow)	محرث رباعي الشقوق
8 furrow	ثلم (شق المحراث)	41 combination seed-harrow	مشط التنطير
9 stone	حجر الحد	64 Agricultural Machinery I	الآلات الزراعية (1)
10-12 sowing	البسذر	1-33 combine harvester (combine)	الحصاد الآلي
10 sower	عامل نثر البذور	1 divider	المقسم
11 seedlip	بذر البذور	2 grain lifter	رافعة الحبوب
12 seed corn (seed)	كيس البذور	3 cutter bar	مضرب الحصد
13 field guard	حارس الحقول (الخفير)	4 pick-up reel, a spring-tine reel	مضرب الضم
14 chemical fertilizer (artificial fertilizer); kinds: potash fertilizer, phosphoric acid fertilizer, lime fertilizer, nitrogen fertilizer	سماد كيمياوي (سماد صناعي) أنواعه: البوتاس، وحمض الفوسفوريك والكالسيوم والأزوت	5 reel gearing	تروس المضرب
15 cartload of manure (farmyard manure, dung)	حمولة عربة من السماد العضوي	6 auger	حلزون تغذية ناقل
16 oxteam (team of oxen, Am. span of oxen)	ثيران جز (زوج من الثيران)	7 chain and slat elevator	سبير رافع سلسلي
17 fields (farmland)	حقول (أرض المزرعة)	8 hydraulic cylinder for adjusting the cutting unit	أسطوانة هيدرولية لضبط وحدة الحصد
18 farm track (farm road)	طريق المزرعة	9 stone catcher (stone trap)	مضيدة الحصى
19-30 hay harvest (hay-making)	تجيبس الكلا	10 awner	مزرع السفا، سفافة
19 rotary mower with swather (swath reaper)	محصنة دوارة ذات آلة حش وتكويم	11 concave	سطح مقعر
20 connecting shaft (connecting rod)	عمود توصيل	12 threshing drum (drum)	برميل النرس (وعاء)
21 power take-off (power take-off shaft)	عمود نقل الحركة (مأخذ القدرة)	13 revolving beater [for freeing straw from the drum and preparing it for the shakers]	دائرة التدرية (المضرب) [لفصل القش من البرميل وإعداده للهزات]
22 meadow	مزرعى	14 straw shaker (strawwalker)	غربال هزاز (رداخ)
23 swath (swathe)	كومة	15 fan for compressed-air winnowing	مروحة التدرية
24 tedder (rotary tedder)	مبيسة الكلا (مقلب كلا دوارة)	16 preparation level	سطح التحجيز
25 tedded hay	كلا ميبس	17 louvred-type sieve	غربال مزدوج
26 rotary swather	آلة حش وتكويم دوارة	18 sieve extension	امتداد الغربال
27 trailer with pick-up attachment	مقطورة لها ملحق لربط شاحنة خفيفة	19 shoe sieve (reciprocating sieve)	غربال سفلي
28 fence rack (rickstand), a drying rack for hay	مبلف القش	20 grain auger	بريمة حلزون الحبوب
29 rickstand, a drying rack for hay	رف تجفيف الكلا	21 tailings auger	حصيرة نقل القش
30 hay tripod	حامل كلا ثلاثي	22 tailings outlet	فتحة تصريف
31-41 grain harvest and seedbed preparation	حصاد الحبوب وتجهيز مفضل البذور	23 grain tank	قادوس الحبوب
31 combine harvester	الحصاد الآلي	24 grain tank auger	حلزون قادوس الحبوب
32 cornfield	حقل القمح/الذرة	25 augers feeding to the grain tank unloader	حلزونات تغذية آلية لتفريغ قادوس الحبوب
33 stubble field	حقل الجذامات	26 grain unloader spout	مزاب آلية لتفريغ القادوس
34 bale of straw	بالة قش	27 observation ports for checking tank contents	فتحات ملاحظة لمتابعة محتويات القادوس
35 straw baler (straw press), a high-pressure baler	محصمة البالات	28 six-cylinder diesel engine	محرك ديزل ذو ست أسطوانات
36 swath (swathe) of straw (windrow of straw)	صف/كومة قش	29 hydraulic pump with oil reservoir	مضخة هيدرولية مع خزان زيت
		30 driving axle gearing	تروس محور الإدارة
		31 driving wheel tyre (Am. tire)	إطار عجلة الإدارة
		32 rubber-tyred (Am.	عجلة ذات إطار مطاطي

rubber-tired) wheel on the steering axle	على محور التوجيه	gearing	متعددة الخطوات	10 knife coultter (<i>Am.</i> colter), a colter	سكين قطع	hitch)	الرادياتير، المشيع
33 driver's position	موضع السائق	72 feeder	آلية التغذية	11 skim coultter (<i>Am.</i> colter)	مكشط	51 radiator	مروحة
34-39 self-propelled forage harvester (self-propelled field chopper)	حصادة علف متحركة	73 haulm stripper (flail rotor)	جهاز إزالة الأعشاب	12 guide-chain crossbar	قضيب السلسلة الدليلية	52 fan	المطارية
34 cutting drum (chopper drum)	برميل الحصد	74 rotary elevating drum	برميل رفع دوار	13 guide chain	سلسلة دليلية	53 battery	مُرْبَعُ هَوَاءِ ذُو حِصَامِ زَيْتِي
35 corn head	رأس حصد الذرة	75 mechanical tumbling separator	فرآزة حيوب آلية	14-19 forecarriage	العربة الأمامية	54 oil bath air cleaner (oil bath air filter)	عِزَاقَةٌ، مِعْرَقَةٌ
36 cab (driver's cab)	كابينة السائق	76 haulm conveyor with flexible haulm strippers	ناقل الأعشاب ذو جهاز إزالة الأعشاب	14 adjustable yoke	مقرن انضباطي	55 cultivator (grubber)	إطار مقطعي
37 swivel-mounted spout (discharge pipe)	ماسورة تصريف مُركَّبة	77 haulm conveyor agitator	محرّك ناقل الأعشاب	15 land wheel	دولاب، عجلة	56 sectional frame	أسنان مَرَبَّة
38 exhaust	على محور دواراني	78 haulm conveyor drive with V-belt	إدارة ناقل الأعشاب ذات سير حرف V	16 furrow wheel	عجلة الفج	57 spring tine	مقطع، سلاح
39 rear-wheel steering system	نظام توجيه الدولاب الخلفي	79 studded rubber belt for sorting vines, clods and stones	إدارة ناقل الأعشاب ذات سير مطاطي بارز لقرن الكروم والمدر والحجارة	17 hake chain	سلسلة وصلة الجر	58 share, a diamond-shaped share (<i>sim.</i> : chisel-shaped share)	عجلة تحديد الأعماق
40-45 rotary swather	آلة حش وتكويم دوّارة	80 trash conveyor	ناقل الفضلات	18 draught beam (draw-bar)	وصلة الجر	59 depth wheel	تعديل العمق
40 cardan shaft	عمود كردان	81 sorting table	نضد الفرز	19 hake	وصلة الجر	60 depth adjustment	وصلة الجر
41 running wheel	دولاب متحرك	82 rubber-disc (rubber-disk) rollers for pre-sorting	أسطوانة قرصية مطاطية للفرز الأولي	20 tractor (general-purpose tractor)	جرّار للأغراض العامة	61 coupling (hitch)	محرّات انعكاسي
42 double spring tine	شوكّة ذات نابضين	83 discharge conveyor	ناقل التصريف	21 cab frame (roll bar)	إطار كابينة السائق	62 reversible plough (<i>Am.</i> plow), a mounted plough	عجلة تحديد الأعماق
43 crank	ذراع التّؤوير	84 endless-floor hopper	قادوس الجمع	22 seat	مقعد	63 depth wheel	عجلة تحديد الأعماق
44 swath rake	سُطَط الحش	85-96 beet harvester	حصادة الشمندر	23 power take-off gear-change (gearshift)	مجموعة مأخذ القدرة	64-67 plough (<i>Am.</i> plow) bottom, a general-purpose plough bottom	بدن المحرّات، بدن محرّات للأغراض العامة
45 three-point linkage	وصلة ثلاثية	86 feeler	آلية الشرفقة	24-29 power lift	مرفاع كهربائي	64 mouldboard (<i>Am.</i> moldboard)	القلاب، المقلب، المطرقة
46-58 rotary tedder	ناشرة الدريس الدوّارة	87 topping knife	الخصاس	24 ram piston	كباس تضاعفي	65 ploughshare (share, <i>Am.</i> plowshare), a pointed share	المقطع
46 tractor	جرّار	88 feeler support wheel with depth adjustment	دولاب حامل الحساس	25 lifting rod adjustment	مضيق الرفع	66 sole (slade)	المرّحف
47 draw bar	قضيب الجر	89 beet cleaner	أداة تنظيف الشمندر	26 drawbar frame	مكبّط الرفع	67 landside	المسند
48 cardan shaft	عمود كردان (عمود نقل الحركة)	90 haulm elevator	مصعد الأعشاب	27 top link	مكبّط قضيب الجر	68 skim coultter (<i>Am.</i> colter)	المكشط
49 power take-off (power take-off shaft)	مأخذ القدرة	91 hydraulic pump	مضخة هيدروليكية	28 lower link	وصلة علوية	69 disc (disk) coultter (<i>Am.</i> colter) (rolling coultter)	مكشط قرصي
50 gearing (gears)	تروس السرعة	92 compressed-air reservoir	أسطوانة هواء مضغوط	29 lifting rod	وصلة سفلية	70 plough (<i>Am.</i> plow) frame	إطار المحرّات
51 frame bar	قضيب الهيكل	93 oil tank (oil reservoir)	خزان الزيت	30 drawbar coupling	قضيب الرفع	71 beam (plough beam, <i>Am.</i> plowbeam)	قصبية المحرّات
52 rotating head	رأس دوار	94 tensioning device for the beet elevator	جهاز شدّ الخاص بمصعد الشمندر	31 live power take-off (live power take-off shaft, take-off shaft)	مقرن قضيب الجر	72 three-point linkage	وصلة ثلاثية
53 tine bar	قضيب حمل الشوكّة	95 beet elevator belt	سير مصعد الشمندر	32 differential gear (differential)	عمود نقل الحركة/ مأخذ القدرة	73 swivel mechanism	آلية محور الدوران
54 double spring tine	شوكّة ذات نابضين	96 beet hopper	قادوس جمع الشمندر	33 floating axlc	القدرة	74 drill	جهاز تنطير البذور
55 guard rail	قضيب واق	65 Agricultural Machinery II	الآلات الزراعيّة (2)	34 torque converter lever	تروس فرقيّة	75 seed hopper	صندوق البذور
56 running wheel	دولاب متحرك	1 wheel plough (<i>Am.</i> plow), a single-bottom plough [<i>form.</i>]	محرّات بجعل، محرّات ذو بدن واحد	35 gear-change (gearshift)	مخور طاف	76 drill coultter (<i>Am.</i> colter)	مكشط جهاز التنطير
57 height adjustment crank	ذراع ضبط الارتفاع	2 handle	مقبض، مقود	36 multi-speed transmission	ذراع محول عزم الدوران	77 delivery tube, a telescopic tube	أنبوب البذور، أنبوب تليسكوبي
58 wheel adjustment	ضبط اتجاه الدولاب	3 plough (<i>Am.</i> plow) stilt (plough handle)	مقبض المحرّات	37 fluid clutch (fluid drive)	نقل السرعة، نقل التروس	78 feed mechanism	آلية التلقين
59-84 potato harvester	حصادة البطاطس	4-8 plough (<i>Am.</i> plow) bottom	بدن المحرّات	38 power take-off gear	نقل حركة متعدد السرعات	79 gearbox	صندوق التروس
59 control levers for the lifters of the digger and the hopper and for adjusting the shaft	ضبط اتجاه الدولاب	4 mouldboard (<i>Am.</i> moldboard)	القلاب، المقلب، المطرقة	39 main clutch	إدارة مايعية	80 drive wheel	عجلة الإدارة
60 adjustable hitch	ضبط اتجاها الدولاب	5 landside	المسند	40 power take-off gear-change (gearshift) with power take-off clutch	تروس مأخذ القدرة مع قابض مأخذ القدرة	81 track indicator	مؤشر الأعداد
61 drawbar	قضيب الجر	6 sole (slade)	المرّحف	41 hydraulic power steering and reversing gears	تروس مأخذ القدرة	82 disc (disk) harrow, a semimounted implement	مشط قرصي
62 drawbar support	حامل قضيب الجر	7 ploughshare (share, <i>Am.</i> plowshare)	مقطع، سلاح المحرّات	42 fuel tank	تروس مأخذ القدرة	83 discs (disks) in X-configuration	أقراص في تشكيل متصالب
63 cardan shaft connection	وصلة عمود الكردان	8 frog (frame)	النسر (إطار)	43 float lever	تروس مأخذ القدرة مع قابض مأخذ القدرة	84 plain disc (disk)	قرص مستو
64 press roller	أسطوانة المكبس	9 beam (plough beam, <i>Am.</i> plowbeam)	قصبية المحرّات	44 four-cylinder diesel engine	توجيه هيدرولي وتروس السرعة الخلفية	85 serrated-edge disc (disk)	قرص موج
65 gearing (gears) for the hydraulic system	تروس النظام الهيدرولي			45 oil sump and pump for the pressure-feed lubrication system	خزان الوقود	86 quick hitch	وصلة الجر
66 disc (disk) coultter (<i>Am.</i> colter) (rolling coultter)	سكين قرصي			46 fresh oil tank	ذراع العوامة	87 combination seed-	مشط تنطير
67 three-bladed share	سلاح ذو ثلاثة أنصال			47 track rod (<i>Am.</i> tie rod)	محرك ديزل رباعي الاسطوانات		
68 disc (disk) coultter (<i>Am.</i> colter) drive	إدارة السكين القرصي			48 front axle pivot pin	خض ومضخة الزيت		
69 open-web elevator	سير ناقل مكشوف			49 front axle suspension	لنظام التزييق تحت الضغط		
70 agitator	محرّك			50 front coupling (front			
71 multi-step reduction	تروس خفض السرعة						

harrow	سُطَط بِأَسنان جَسِيمة ثلاثي المقاطع	11 centrifugal evacuating pump	مضخة تفريغ نابذة	(head)	سُنْبِلَة	ing to colour: white (Am. Irish), yellow, red, purple potato	
88 three-section spike-tooth harrow	سُطَط بِأَسنان جَسِيمة ثلاثي المقاطع	12 basket strainer	مصفاة سَلِيَة	3 spikelet	حَبَة مُصابَة بمرض الدَّابَّرَة [موضحة بالفَرْغ الفِطْرِي]	39 seed potato (seed tuber)	ذُرَّة بَذْرِيَة
89 three-section rotary harrow	سُطَط دوراني ثلاثي المقاطع	13 channel	قناة	4 ergot, a grain deformed by fungus [shown with mycelium]	ساق الذرة بعد التفريغ	40 potato tuber (potato, tuber)	درنة البطاطس
90 frame	إطار	14 chassis of the p.t.o.-driven pump (power take-off-driven pump)	شاسيه مضخة تعمل بعمود لنقل الحركة	5 corn stem after tillering	ساق	41 potato top (potato haulm)	وَرَقَة البطاطس (قصبه البطاطس)
66 Agricultural Implements	الأدوات المزارعية	15 p.t.o.-driven (power take-off-driven) pump	مضخة تعمل بعمود نقل للحركة	6 culm (stalk)	عَقْدَة الساق	42 flower	زَهْرَة
1 draw hoe (garden hoe)	مِعْرَق يدوي	16 cardan shaft	عمود كاردان	7 node of the culm	ورقة (ورقة الحَبَة)	43 poisonous potato berry (potato apple)	سَمِّ البطاطس
2 hoe handle	عصا المِعْرَق	17 tractor	جَرَّار	8 leaf (grain leaf)	عَضْفَة	44 sugar beet, a beet	بَنْجَر أو سَمْتَدَر سكري
3 three-pronged (three-tined) hay fork (fork)	شوكَة قش ذات ثلاث سَعَب	18 long-range irrigation unit	وَحْدَة رَي بعيدة المدى	9 leaf sheath (sheath)	سَفَاة	45 root (beet)	جذر
4 prong (tine)	شُعْبَة الشوكَة	19 drive connection	وَصْلَة الإدارة	10 spikelet	بذرة (حَبَة)، نواة حَبَة طَحِينِيَة	46 beet top	رأس شرة البنجر
5 potato fork	شوكَة بطاطس	20 turbine	توربين	11 glume	نبات جنيني	47 beet leaf	ورقة البنجر
6 potato hook	شوكَة بطاطس	21 gearing (gears)	التروس	12 awn (beard, arista)	حَبَة، بذرة		
7 four-pronged (four-tined) manure fork (fork)	شوكَة بسماد رباعية السَعَب	22 adjustable support	حامل قابل للضبط	13 seed (grain, kernel, farinaceous grain)	مِبْضَخَة تفريغ نابذة		
8 manure hoe	مِعْرَق السَماد	23 centrifugal evacuating pump	مِبْضَخَة تفريغ نابذة	14 embryo plant	عَجَلَة	69 Fodder Plants (Forage Plants)	محاصيل العلف (نباتات الكلال)
9 whetting hammer [for scythes]	مِبْطَرَقَة شَحْد [للحاصدة]	24 wheel	عَجَلَة	15 seed	حامل الماسورة	1-28 fodder plants (forage plants) for tillage	نباتات الكلال للفلاحة
10 peen (pane)	حَد المِبْطَرَقَة	25 pipe support	حامل الماسورة	17 root	ماسورة من البوليستر	1 red clover (purple clover)	نَقْل بنفسجي، نقل المروج
11 whetting anvil [for scythes]	سِدْمان شَحْد [للحاصدة]	26 polyester pipe	ماسورة من البوليستر	18 root hair	فُوَهَة المرشَة	2 white clover (Dutch clover)	بَرْسيم هولندي، نقل أبيض
12 scythe	حاصدة، مجس، منجل	27 sprinkler nozzle	فُوَهَة المرشَة	19 grain leaf	وَصْلَة ماسورة سريعة	3 alsike clover (alsike)	بَرْسيم السويد، نقل هجين
13 scythe blade	سلاح الحاصدة	28 quick-fitting pipe connection with cardan joint	وَصْلَة ماسورة سريعة التركيب ذات وصلة كاردان	20 leaf blade (blade, lamina)	وَصْلَة كارداني-إيم	4 crimson clover	نقل مدعى
14 cutting edge	حافة قاطعة	29 M-cardan	وَصْلَة كارداني-إيم	21 leaf sheath	قَامِطَة تثبيت	5 four-leaf (four-leaved) clover	بَرْسيم رباعي الورقات
15 heel	كَعَب سلاح الحاصدة	30 clamp	كردان إسفيني	22 ligule (ligula)	كردان إسفيني	6 kidney vetch (lady's finger, lady-finger)	نقل الرمال الأصفر
16 snath (snathe, snead, sneath)	مِقْبَض الحاصدة	31 V-cardan	مرشَة دَوَّارَة	23 wheat	مرشَة دَوَّارَة	7 flower	زَهْرَة
17 handle	مِقْبَض	32 revolving sprinkler, a field sprinkler	فُوَهَة	24 spelt	ذراع قطع الرَش	8 pod	سَفَة، عَلْفَة، قَرْن
18 scythe sheath	عِمْد الحاصدة	33 nozzle	فُوَهَة	25 seed; <i>unripe</i> : green spelt, a soup vegetable	ناضج ذراع إيقاف الرَش	9 lucerne (lucerne, purple medick)	مِقْبَضَة (رطبة)
19 whetstone (scythe-stone)	حَجَر المِس	34 breaker	ذراع قطع الرَش	26 barley	سِدْادَة	10 sainfoin (cock's head, cockshead)	إيدوسارون، رأس الديك
20 potato rake	قَشاشَة البطاطس	35 breaker spring	ناضج ذراع إيقاف الرَش	27 oat panicle, a panicle	يَقْل موازن	11 bird's foot (bird-foot, bird's foot trefoil)	قَرْن الفَزال (لوطس قرني)
21 potato planter	زَرَاعة البطاطس	36 stopper	سِدْادَة	28 millet	حَزور، لَوْبِيَة	12 corn spurrey (spurrey, spurry), a spurrey (spurry)	إسْبِرغولَة
22 digging fork (fork)	شوكَة حفر (شوكَة)	37 counterweight	يَقْل موازن	29 rice	أنواع من الحبوب (حَبَة، غلال، نباتات طحينية، القمح)	13 common comfrey, one of the borage family (Boraginaceae)	سَفِينون مَحْرَتي، نبات من المصمحات
23 wooden rake (rake, hayrake)	سُطَط خشبي (سُطَط، سُطَط القش)	38 thread	حَزور، لَوْبِيَة	30 rice grain	المحاصيل المزارعية	14 flower (blossom)	زَهْرَة
24 hoe (potato hoe)	مِعْرَق (مِعْرَق البطاطس)	68 Arable Crops	المحاصيل المزارعية	31 maize (Indian corn, Am. corn); <i>varieties</i> : popcorn, dent corn, flint corn (flint maize, Am. Yankee corn), pod corn (Am. cow corn, husk corn), soft corn (Am. flour com, squaw com), sweet corn	المحاصيل المزارعية	15 field bean (broad bean, tick bean, horse bean)	فول الحقل
25 potato basket, a wire basket	سَلَة جمع البطاطس، سَلَة سلكية	1-47 arable crops (agricultural produce, farm produce)	أنواع من الحبوب (حَبَة، غلال، نباتات طحينية، القمح)	32 female inflorescence	أنواع من الحبوب (حَبَة، غلال، نباتات طحينية، القمح)	16 pod	سَفَة، عَلْفَة، قَرْن
26 clover broadcaster	آلة نَقْر حبوب البرسيم	1-37 varieties of grain (grain, cereals, farinaceous plants, bread-com)	أنواع من الحبوب (حَبَة، غلال، نباتات طحينية، القمح)	33 husk (shuck)	أنواع من الحبوب (حَبَة، غلال، نباتات طحينية، القمح)	17 yellow lupin	تُرْمَس أصفر عطر
67 Overhead Irrigation	الموي بالرش	1 rye (<i>also</i> : corn, 'corn' often meaning the main cereal of a country or region; in Northern Germany: rye; in Southern Germany and Italy: wheat; in Sweden: barley; in Scotland: oats; in North America: maize; in China: rice)	سَلْت، شَيْلم (ويطعن الغلال الرئيسية في بلد أو إقليم؛ في شمال ألمانيا شَيْلم؛ جنوب ألمانيا وإيطاليا القمح؛ السويد الشعير؛ اسكوتلندا الشوفان؛ أمريكا الشمالية الذرة؛ الصين الأرز)	34 style	سَلْت، شَيْلم (ويطعن الغلال الرئيسية في بلد أو إقليم؛ في شمال ألمانيا شَيْلم؛ جنوب ألمانيا وإيطاليا القمح؛ السويد الشعير؛ اسكوتلندا الشوفان؛ أمريكا الشمالية الذرة؛ الصين الأرز)	18 common vetch	مِقْبَضَة شائعة
1 oscillating spray line	خَط رَش تَأرجحي	2 ear of rye, a spike	سَلْت، شَيْلم (ويطعن الغلال الرئيسية في بلد أو إقليم؛ في شمال ألمانيا شَيْلم؛ جنوب ألمانيا وإيطاليا القمح؛ السويد الشعير؛ اسكوتلندا الشوفان؛ أمريكا الشمالية الذرة؛ الصين الأرز)	35 male inflorescence (tassel)	سَلْت، شَيْلم (ويطعن الغلال الرئيسية في بلد أو إقليم؛ في شمال ألمانيا شَيْلم؛ جنوب ألمانيا وإيطاليا القمح؛ السويد الشعير؛ اسكوتلندا الشوفان؛ أمريكا الشمالية الذرة؛ الصين الأرز)	19 chick-pea	حَصَص، العلامَة
2 stand (steel chair)	حامل صلب			36 maize cob (Am. corn cob)	سَلْت، شَيْلم (ويطعن الغلال الرئيسية في بلد أو إقليم؛ في شمال ألمانيا شَيْلم؛ جنوب ألمانيا وإيطاليا القمح؛ السويد الشعير؛ اسكوتلندا الشوفان؛ أمريكا الشمالية الذرة؛ الصين الأرز)	20 sunflower	عُباد/دَوَّار الشمس
3 portable irrigation system	نظام ري قابل للحمل			37 maize kernel (grain of maize)	سَلْت، شَيْلم (ويطعن الغلال الرئيسية في بلد أو إقليم؛ في شمال ألمانيا شَيْلم؛ جنوب ألمانيا وإيطاليا القمح؛ السويد الشعير؛ اسكوتلندا الشوفان؛ أمريكا الشمالية الذرة؛ الصين الأرز)	21 mangold (mangel-wurzel, mangold-wurzel, field mangel)	سَمْتَدَر، بَنْجَر، سلق
4 revolving sprinkler	مرشَة دَوَّارَة			38 potato plant (potato), a tuberous plant; <i>varieties</i> : round, round-oval (pear-shaped), flat-oval, long, kidney-shaped potato; <i>accord-</i>	سَلْت، شَيْلم (ويطعن الغلال الرئيسية في بلد أو إقليم؛ في شمال ألمانيا شَيْلم؛ جنوب ألمانيا وإيطاليا القمح؛ السويد الشعير؛ اسكوتلندا الشوفان؛ أمريكا الشمالية الذرة؛ الصين الأرز)	22 false oat (oat-grass)	خَرْطال عادي
5 standpipe coupler	مِقْرَن العواشير القائمة				سَلْت، شَيْلم (ويطعن الغلال الرئيسية في بلد أو إقليم؛ في شمال ألمانيا شَيْلم؛ جنوب ألمانيا وإيطاليا القمح؛ السويد الشعير؛ اسكوتلندا الشوفان؛ أمريكا الشمالية الذرة؛ الصين الأرز)	23 spikelet	سُنْبِلَة
6 elbow with cardan joint (cardan coupling)	مِرْفَق ذو وَصْلَة كاردانيَة				سَلْت، شَيْلم (ويطعن الغلال الرئيسية في بلد أو إقليم؛ في شمال ألمانيا شَيْلم؛ جنوب ألمانيا وإيطاليا القمح؛ السويد الشعير؛ اسكوتلندا الشوفان؛ أمريكا الشمالية الذرة؛ الصين الأرز)	24 meadow fescue grass, a	سَفْتوكَة
7 pipe support (trestle)	حامل الماسورة (مَبْضَب)				سَلْت، شَيْلم (ويطعن الغلال الرئيسية في بلد أو إقليم؛ في شمال ألمانيا شَيْلم؛ جنوب ألمانيا وإيطاليا القمح؛ السويد الشعير؛ اسكوتلندا الشوفان؛ أمريكا الشمالية الذرة؛ الصين الأرز)		
8 pump connection	وَصْلَة المضخة				سَلْت، شَيْلم (ويطعن الغلال الرئيسية في بلد أو إقليم؛ في شمال ألمانيا شَيْلم؛ جنوب ألمانيا وإيطاليا القمح؛ السويد الشعير؛ اسكوتلندا الشوفان؛ أمريكا الشمالية الذرة؛ الصين الأرز)		
9 delivery valve	صمام الطرد				سَلْت، شَيْلم (ويطعن الغلال الرئيسية في بلد أو إقليم؛ في شمال ألمانيا شَيْلم؛ جنوب ألمانيا وإيطاليا القمح؛ السويد الشعير؛ اسكوتلندا الشوفان؛ أمريكا الشمالية الذرة؛ الصين الأرز)		
10 pressure gauge (Am.	مقياس الضغط (مانومتر)				سَلْت، شَيْلم (ويطعن الغلال الرئيسية في بلد أو إقليم؛ في شمال ألمانيا شَيْلم؛ جنوب ألمانيا وإيطاليا القمح؛ السويد الشعير؛ اسكوتلندا الشوفان؛ أمريكا الشمالية الذرة؛ الصين الأرز)		

fescue		29 dog comb	منشط الكلاب	20 shaft chain (pole chain)	بسلسلة عريش العربية	7 nostril	فتحة الأنف
25 cock's foot (cocksfoot)	نجيل الإصبع [اصمعية مجتعبة]	30 lead (dog lead, leash); for hunting: leash	مقود الكلب (السلسلة)	21 pole	عريش ، قضيب	8 upper lip	الشفة العليا
26 Italian ryegrass; sim.: perennial ryegrass (English ryegrass)	زوان إيطالي؛ و مثله زوان شعمر	31 muzzle	كمامة الخنم	22 trace	سند الجوز	9 mouth	الحنك
27 meadow foxtail, ■ pan- iculate grass	ثعلبية المروج	32 feeding bowl (dog bowl)	وعاء الطعام	23 second girth (emer- gency girth)	حزام احتياطي للسرج	10 underlip (lower lip)	الشفة السفلى
28 greater burnet saxifrage	كاسر الحجر	33 bone	عظمة	24 trace	سند الجوز	11 lower jaw	الفك السفلي
70 Breeds of Dog	فصائل الكلاب	34 Newfoundland dog	كلب نيوفوندلاند	25 reins (<i>Am. lines</i>)	العنان، السرج	12 crest (neck)	عرف الحصان
1-14 mastiffs	سلالات الذؤواس	35 schnauzer	الشنوزر	26-36 breast harness	عدة الصدر	13 mane (horse's mane)	شعر عنق الحصان
1 bulldog	البيدغ	36 poodle; <i>sim. and smaller: pygmy pigmy</i>) poodle	البودل، القزم	26 blinker (<i>Am. blinder, winker</i>)	غمامة الفرس	14 crest (horse's crest)	عرف الحصان
2 ear, a rose-ear	أذن	37 St. Bernard (St. Bernard dog)	السنبرنار	27 breast collar ring		15 neck	الرقبة، العنق
3 muzzle	الحنك	37-43 hunting dogs	كلاب الصيد	28 breast collar (Dutch collar)		16 throat (<i>Am. throatlatch, throatlash</i>)	الحنك، الزور
4 nose	أنف	38 cocker spaniel	الكلاب الصيد	29 fork		17 withers	الصارك، الكائبة
5 foreleg	الرجل الأمامية		الكوكري، كلب صغير	30 neck strap		18-27 forehand	مقدم الحصان
6 forepaw	مخبط أمامي	39 dachshund, ■ terrier	مسترخي الأذنين حريري الشهيد	31 saddle-pad		18 shoulder	كتف
7 hind leg	الرجل الخلفية	40 German pointer	كلب صيد ذو ذيل صغير	32 loin strap		19 breast	صدر
8 hind paw	مخبط خلفي	41 English setter	مدب	33 reins (rein, <i>Am. line</i>)		20 elbow	مرفق
9 pug (pug dog)	البيج جنس من الكلاب الصغيرة يشبه البيدغ وله أنف أقفس	42 trackhound	الساطر الإنجليزي كلب صيد تدرب على الوقوف حالمًا يشتم القنص	34 crupper (crupper-strap)		21 forearm	ساعد
		43 pointer, a trackhound	قصاص الأثر (كلب صيد) قصاص الأثر (كلب صيد)	35 trace		22-26 forefoot	القائمة الأمامية
10 boxer	البيكسر			36 girth (belly-band)		22 knee (carpus, wrist)	ركبة
11 withers	الصارك، العاراب	71 Horse I	الحصان/ الفرس (I)	37-44 stock saddle (<i>Am.</i> western saddle)		23 cannon	الوظيف
12 tail, a docked tail	ذيل، ذيل مبثور	1-6 equitation (high school riding, haute école)	ركوب الخيل، الفروسية	37 saddle seat		24 fetlock	ثنية
13 collar	طوق	7-25 harness		38 pommel horn (horn)		25 pastern	مفصل الرسغ
14 Great Dane	الداني فصيلة من الكلاب الضخمة قصيرة الشعر سلالات الثريير	7-13, 25 bridle		39 cantle		26 hoof	حافر
		7-11 headstall (headpiece, halter)		37-44 stock saddle (<i>Am.</i> western saddle)		27 chestnut (castor), a callosity	جساة، الكستانة
15-18 terriers	الثرير	7 noseband	منحطمة، حنطام	37 saddle seat		28 spur vein	وريد مهمازي
15 wire-haired fox terrier	الثرير ذو الفروة الشائكة (فصيلة من كلاب الصيد)	8 cheek piece (cheek strap)	العذار	38 pommel horn (horn)		29 back	الظهر، الصهوة
16 bull terrier	الثرير الضخم	9 browband (front band)	منحطمة، حنطام	39 cantle		30 loins (lumbar region)	الخاصرة
17 Scotch terrier (Scottish terrier)	الثرير الاسكتلندي	10 crownpiece	منحطمة، حنطام	40 flap (<i>Am. fender</i>)		31 croup (rump, crupper)	كفل/ردف الحصان
18 Bedlington terrier	الثرير بيدلنجتون	11 throatlatch (throatlash)	منحطمة، حنطام	41 bar		32 hip	ورك
19 Pekinese (Pekingese, Pekinese dog, Pekingese dog)	كلب بكين جنس من الكلاب الصغيرة	12 curb chain	منحطمة، حنطام	42 stirrup leather		33-37 hind leg	القائمة الخلفية
20-22 spitzes	فصائل الإسبيتز	13 curb bit	منحطمة، حنطام	43 stirrup (stirrup iron)		33 stifle (stifle joint)	حجبة (مفصل الحجبة)
20 spitz (Pomeranian)	الاسبيتز	14 hasp (hook) of the hame (<i>Am. drag hook</i>)	منحطمة، حنطام	44 blanket		34 root (dock) of the tail	السبيبة (الجزء القاسي من الذيل)
21 chow (chow-chow)	الششاو، كلب صيني	15 pointed collar, a collar	منحطمة، حنطام	45-49 English saddle (cavalry saddle)		35 haunch	إفئة الحصان
22 husky	كلب الإسكوي	16 trappings (side trappings)	منحطمة، حنطام	45 seat		36 gaskin	الفخذ
23-24 greyhounds (<i>Am.</i> grayhounds)	سلالات السلوقي	17 saddle-pad	منحطمة، حنطام	46 cantle		37 hock	عرقوب
23 Afghan (Afghan hound)	الكلب الأفغاني كلب سريع من فصيلة السلوقي يستخدم في الصيد	18 girth	منحطمة، حنطام	47 flap		38 tail	ذيل
24 greyhound (<i>Am. gray- hound</i>), a courser	الكلب الأفغاني كلب سريع من فصيلة السلوقي يستخدم في الصيد	19 backband	منحطمة، حنطام	48 roll (knee roll)		39-44 gaits of the horse	أوضاع المشي والجري
25 Alsatian (German sheepdog, <i>Am. German shepherd</i>), ■ police dog, watch dog, and guide dog	كلب حراسة (الراعي الألماني)، كلب بوليسي		منحطمة، حنطام	49 pad		39 walk	عند الحصان
26 flews (chaps)	الجزء المعدلي من شفة الكلب العليا		منحطمة، حنطام	50-51 spurs		40 pace	السير العادي
27 Doberman terrier	الدويرمان		منحطمة، حنطام	50 box spur (screwed jack spur)		41 trot	الخبيب البطيء
28 dog brush	فرشاة الكلاب		منحطمة، حنطام	51 strapped jack spur		42 canter (hand gallop)	الخبيب السريع

3 donkey	فَرَسَة صَغِير (مَهْر)	74 Poultry Farming (Poultry Keeping), Egg Production	مَرْعَة / تَرْبِيَّة الدواجن، إنتاج البيض	(dunging conveyor) setting and hatching machine	مَأْكِنَة حَضَنَ وَفَقَسَ البيض	cock's treadle	الحَوْضِيَّة الجروثومية
4 pack saddle (carrying saddle)	سَرْجَ الحِمْل (بِوَدْعَة)	1-27 poultry farming (intensive poultry management)	مَرْعَة الدواجن	29 ventilation drum [for the setting compartment]	أَسْطُوَانَة / بِرْمِيل تَهْوِيَة [الحَجِيرَة الحَضَنَ]	66 germinal vesicle	زَلَالَ البيض
5 pack (load)	حِمْل	1-17 straw yard (strawed yard) system	نِظَام سَاحَة التَّن	30 hatching compartment (hatcher)	حَجِيرَة الفَقَس	67 white	المُح
6 tufted tail	ذَيْلٌ يَنْتَهِي بِخِصْلَة	1 fold unit for growing stock (chick unit)	وَحْدَة تَرْبِيَة الكِتَاكِيَت	31 metal trolley for hatching trays	تِرْوَالِي مَعْدَنِي لِصَوَانِي الفَقَس	68 yolk	تَرْبِيَّة المَاشِيَّة
7 tuft	خِصْلَة	2 chick	كِكْوَت، صُوص	32 hatching tray	صِيبِيَّة فَقَس	75 Rearing (Am. Raising) of Livestock	الإِسْطِيل
8 mulc, a cross between a male donkey and a mare	بَقْلٌ هَجِينٌ مِّن ذَكَرِ الحِمَارِ وَأُنْثَى الحِمَارِ	3 brooder (hover)	مِفْقَسَة	33 ventilation drum motor	مِحرَك / مِوتور أَسْطُوَانَة التَهْوِيَة	1 stable	إِسْطِيل الحِمَارِ فِي الإِسْطِيل
9 pig, a cloven-hoofed animal; m. boar; f. sow; y. piglet	الخِنْزِير، حَيوانٌ مَشْفُوق الحَافِر (ذَكَرُ خِنْزِيرٍ، أُنْثَى خِنْزِيرَة، صَغِير خِنْوَص)	4 adjustable feeding trough	وِعَاءٌ عِلْفَة قَابِلٌ لِتَعْدِيلِ حِجْمِهِ	34 egg collection system (egg collection)	إِنْتِاجَ البيضِ نِظَامَ جَمْعِ البيضِ	2 horse stall (stall, horse box, box)	قِطَاعَ العِلْفِ / التَغْدِيَة
10 pig's snout (snout)	أُذُنُ الخِنْزِيرِ	5 pullet fold unit	وَحْدَة تَرْبِيَة الدِجَاج الصَغِير	35 multi-tier transport	نِظَامَ نَقْلِ تَعَدُّدِ الطَبَقَاتِ	3 feeding passage	مَهْر، حِمَارِ صَغِير
11 pig's ear	ذَيْلٌ مَعْفُوص	6 drinking trough	وِعَاءُ الشْرَبِ	36 collection by pivoted fingers	نِظَامَ نَقْلِ تَعَدُّدِ الطَبَقَاتِ	4 pony	قَضْبَانِ
12 curly tail	شَاةٌ (ذَكَرٌ كَيْشٌ، خِرُوفٌ مَخْصِي، أُنْثَى نَعْجَة)	7 water pipe	مَاسورَة مِيَاه	37 drive motor	نِظَامَ نَقْلِ تَعَدُّدِ الطَبَقَاتِ	5 bars	فَضْلَاتٌ مِثَابِرَة، مِهَادٌ مِّنَ الفَقَسِ
13 sheep, m. ram; c. wether; f. ewe; y. lamb	صَغِير (حَمَلٌ)	8 litter	قَش	38 sorting machine	نِظَامَ نَقْلِ تَعَدُّدِ الطَبَقَاتِ	6 litter	بَالَة فَتَش
14 goat	مِعْرَاة، مَاعِزٌ	9 pullet	دِجَاجَة صَغِيرَة	39 conveyor trolley	نِظَامَ نَقْلِ تَعَدُّدِ الطَبَقَاتِ	7 bale of straw	سَقْفٌ
15 goat's beard	لِخِيَّة المِعْرَاة	10 ventilator	مِنْفَذٌ تَهْوِيَة	40 fluorescent screen	عَلَى مِجْوَرٍ	8 ceiling light	مِشْبَاحُ السَقْفِ
16 dog, a Leonberger; m. dog; f. bitch; y. pup (puppy, whelp)	الْكَلْبُ (ذَكَرٌ كَلْبٌ، أُنْثَى كَلْبِيَّة، صَغِير جِرْو)	11 chicken run (Am. fowl run)	عِشَّةُ الدِجَاجِ	41 suction apparatus (suction box) for transporting eggs	مِوتور الإِدَارَة	9 sheep pen	حَظِيرَة الخِرَافِ
17 cat, an Angora cat (Persian cat); m. tom (tom cat)	الْقَطُّ (قَط سِيَامِي)، ذَكَرٌ قَطٌّ / مَهْرٌ	12 broiler chicken (broiler)	دِجَاجَة، فُرُوجٌ	42 shelf for empty and full egg boxes	مَأْكِنَة فَرَزٌ	10 mother sheep (ewe)	رَفٌّ تَيْنٌ مَزْدُوجٌ
18-36 small domestic animals	حَيَوَانَاتٌ مَزَلِيَّةٌ صَغِيرَة	13 mechanical feeder (self-feeder, feed dispenser)	جِهَازٌ تَوْزِيْعٌ عِلْفَة أَلِي	43 egg weighers	تِرْوَالِي نَاقِلٌ	11 lamb	تَيْنٌ / حَيْشِيشٌ مِجْفَفٌ كَمْلَفٌ
18 rabbit; m. buck; f. doe	الأَرْنَبُ، (ذَكَرٌ أَرْنَبٌ، أُنْثَى أَرْنَبِيَّة)	14 chain	سَلْسِلَة	44 grading	سِتَّارٌ فُلُورِي	12 double hay rack	حَظِيرَة البَقَرِ الحَلُوبِ
19-36 poultry (domestic fowl)	الطَيُورِ الدَاجِنَة	15 feed supply pipe	أَنْتُوبٌ لِإِمْدَادِ العِلْفَة	45 egg box	جِهَازٌ شَافِطٌ لِنَقْلِ البيضِ	13 hay	الطُولُ
19-26 chicken	فُرُوجٌ	16 mechanical drinking bowl (mechanical drinker)	إِنَاءٌ شَرِبٍ يَمْتَلِئُ أَلِيَا	46 fully automatic egg-packing machine	رَفٌّ لِصِنَادِيْقِ البيضِ	14 dairy cow shed	سَلْسِلَة
19 hen	دِجَاجَة	17 ventilator	مِنْفَذٌ تَهْوِيَة (نِظَامُ الإِقْفَاصِ)	47 radioscope box	الْفَارِغَة وَالمَمْلُوءَة	15-16 tether	قَضْبِي
20 crop (craw)	حَوْصَلَة	18 battery system (cage system)	نِظَامُ البَطَارِيَة	48 radioscope table	مِوازِينِ البيضِ	16 rail	بَقْرَة حَلُوبِ
21 cock (Am. rooster); c. capon	دِيكٌ	19 battery (laying battery)	بَطَارِيَة وَضِعَ البيضِ	49-51 feeder	وَحْدَة تَصْنِيفِ صِنْدُوقِ بِيضِ	17 dairy cow (milch-cow, milker)	صَرَخٌ
22 cockscomb (comb, crest)	عَرْفُ الدِيكِ	20 tiered cage (battery cage, stepped cage)	قَفْصٌ مَتَعَدِّدُ الأَدْوَارِ (قَفْصٌ يَمْعَلُ بِالبَطَارِيَة، قَفْصٌ مَدْرَجٌ)	49 suction transporter	مَصْدُوقُ بِيضِ	18 udder	خِمَّةٌ
23 lap	طَبِيَّةٌ	21 feeding trough	وِعَاءٌ العِلْفَة	50 vacuum line	مَأْكِنَة تَعْبِيَة البيضِ أَلِيَا بِالكَامِلِ	19 teat	أَخْذُودٌ تَصْرِيفِ الرِوثِ
24 wattle (gill, dewlap)	عَنْبٌ	22 egg collection by conveyor	جَمْعُ البيضِ بِوِاسِطَة سَيِّرٍ نَاقِلٍ	51 supply table	جِهَازٌ تَقْلِيمِ العِلْفَة	20 manure gutter	التَخْلُصُ مِنَ الرِوثِ عَن طَرِيقِ قَضْبَانِ انزِلَاقِيَة
25 falcate (falcated) tail	ذَيْلٌ مَعْفُوفٌ	23-27 mechanical feeding and dunging (manure removal, droppings removal)	تَقْدِيمُ العِلْفَة وَالتَخْلُصُ مِنَ الرِوثِ أَلِيَا	52 automatic counting and grading	جِهَازٌ نَقْلِ شَقَاطِ	21 manure removal by sliding bars	مَرْبُطٌ قَصِيرٌ
26 spur	شَوْكَةٌ فِي رِجْلِ الدِيكِ	24 feed hopper	نِظَامُ تَقْدِيمِ العِلْفَة السَّرِيعِ لِتَغْدِيَةِ البَطَارِيَاتِ	53 packing box dispenser	طَاوِلَة التَمْوِينِ / الإِمْدَادِ جِهَازِ العَدِّ وَالتَصْنِيفِ الأَلِي	22 short standing	عَنْبَرٌ حَلَبِ البَقَرِ
27 guinea fowl	الْفِرْعَوُ (دِجَاجٌ حَيْشِي)	25 endless-chain feed conveyor (chain feeder)	قَادوسُ العِلْفَة	54 leg ring	مُوزَعٌ صِنَادِيْقِ التَعْبِيَة	23 milking parlour (Am. parlour), a herringbone parlour	مَمْرٌ / زُدْهَة العَمَلِ
28 turkey; m. turkey cock (gobbler); f. turkey hen	دِيكٌ رُومِي، دِجَاجَة رُومِيَّة	26 water pipe (liquid feed pipe)	جِهَازٌ تَقْدِيمِ عِلْفَة مَزُودِ سِلْسِلَة مَقْفَلَة	55 wing tally (identification tally)	حَلْقَة السَاقِ	24 working passage	الْحَلَابِ، الحَالِبِ
29 fan tail	ذَيْلٌ مَرُوحِي	27 dunging chain	أَنْتُوبُ المَاءِ (أَنْتُوبُ السَوَالِقِ)	56 bantam	بِطَاقَة تَعْرِيفِ (تَبَيَّنَتْ فِي الجِنَاحِ)	25 milker (Am. milkman)	مِجْمُوعَة كَأَسِ الحِمْلَة
30 peacock	طَاووسٌ			57 laying hen	النِظَامُ (دِجَاجِ صَغِيرِ الحِجْمِ)	26 teat cup cluster	أَنْتُوبُ اللَبَنِ
31 peacock's feather	رِيشُ الطَاووسِ			58 hen's egg (egg)	دِجَاجَة بِياضَة	27 milk pipe	خِطُّ هِوَاءِ
32 eye (ocellus)	بِقْعَة، عَيْنٌ			59 eggshell, an egg integument	بِيضَة دِجَاجَة (بِيضَة) قَشْرَة البِيضَة	28 air line	خِطُّ تَقْرِيعِ
33 pigeon; m. cock pigeon	الحِمَامُ، ذَكَرُ الحِمَامِ			60 shell membrane	غِشَاءُ القَشْرَة (الكَثْفُ)	29 vacuum line	كَأَسِ الحِمْلَة
34 goose; m. gander; y. gosling	الإوزُ، ذَكَرُ الإوزِ، صَغِيرُ فِرْحِ الإوزِ			61 air space	فِرَاقٌ بِي هِوَاءِ	30 teat cup	نَافِذَة
35 duck; m. drake; y. duckling	البِطُّ، ذَكَرُ ذِكْرِ البِطِّ، صَغِيرُ بِلِيطَة، فِرْحِ البِطِّ			62 white [of the egg] (albumen)	بِيضَة دِجَاجَة (بِيضَة) قَشْرَة البِيضَة	31 window	مِضْبَحَة نَابِضَة
36 web (palmations) of webbed foot (palmate foot)	وَتْرَة قَدَمٍ ذَاتِ وَتَرَاتٍ			63 chalaza (Am. treadle)	غِشَاءُ القَشْرَة (الكَثْفُ)	32 pulsator	طُورٌ إِطْلَاقِ اللَبَنِ
				64 vitelline membrane (yolk sac)	فِرَاقٌ بِي هِوَاءِ	33 release phase	طُورُ العَضْرِ
				65 blastodisc (germinal disc, cock's tread,	البِّيَاضُ، زَلَالُ البِيضِ	34 squeeze phase	زَرْبِيَّة الخَنَازِيرِ
					كَلَازَاءُ، خِيوطُ الأَحْ	35 pigsty (Am. pigpen, hogpen)	حَظِيرَة صِغَارِ الخَنَازِيرِ
					غِشَاءُ المِخِ	36 pen for young pigs	وِعَاءُ التَغْدِيَة (العِلْفِ)
					الْقَرَصُ الجِروثُومِي	37 feeding trough	حَاجِزٌ، فَاصِلٌ
						38 partition	خِنْزِيرٌ، خِنْوَصٌ
						39 pig, a young pig	حَظِيرَة الإِخْتِاصِ وَالتَخْزِينِ
						40 farrowing and store pen	
						41 sow	خِنْزِيرَة
						42 piglets (Am. shoats,	خِنَانِيصٌ (خِنَانِيصٌ رُضِيَّة)

shots) (sucking pigs for first 8 weeks))	إمداء الثمانية أسابيع الأولى	continuous butter making	أثيوب أمداء الرُبْد مأكية تشكيل الرُبْد مأكية تعبئة
43 farrowing rails	حواجز/ قضبان الإخناص	34 butter supply pipe	أثيوب أمداء الرُبْد مأكية تشكيل الرُبْد مأكية تعبئة
44 liquid manure channel	قناة تصريف الروث السائل	35 shaping machine	أثيوب أمداء الرُبْد مأكية تشكيل الرُبْد مأكية تعبئة
76 Dairy	مَعْمَل الألبان	36 packing machine	أثيوب أمداء الرُبْد مأكية تشكيل الرُبْد مأكية تعبئة
1-48 dairy (dairy plant)	مَعْمَل الألبان (مصنع الألبان)	37 branded butter in 250g packets	أثيوب أمداء الرُبْد مأكية تشكيل الرُبْد مأكية تعبئة
1 milk reception	استقبال اللبن	38 plant for producing curd cheese (curd cheese machine)	أثيوب أمداء الرُبْد مأكية تشكيل الرُبْد مأكية تعبئة
2 milk tanker	صهريج/ خزان اللبن	39 curd cheese pump	أثيوب أمداء الرُبْد مأكية تشكيل الرُبْد مأكية تعبئة
3 raw milk pump	مضخة اللبن الخام (غير المخلوط بالماء)	40 cream supply pump	أثيوب أمداء الرُبْد مأكية تشكيل الرُبْد مأكية تعبئة
4 flowmeter, an oval (elliptical) gear meter	مقياس تدفق اللبن	41 curds separator	أثيوب أمداء الرُبْد مأكية تشكيل الرُبْد مأكية تعبئة
5 raw milk storage tank	خزان اللبن الخام	42 sour milk vat	أثيوب أمداء الرُبْد مأكية تشكيل الرُبْد مأكية تعبئة
6 gauge (<i>Am. gage</i>)	مقياس	43 stirrer	أثيوب أمداء الرُبْد مأكية تشكيل الرُبْد مأكية تعبئة
7 central control room	غرفة التحكم المركزي	44 curd cheese packing machine	أثيوب أمداء الرُبْد مأكية تشكيل الرُبْد مأكية تعبئة
8 chart of the dairy	مخطط منتجات اللبن	45 packeted curd cheese	أثيوب أمداء الرُبْد مأكية تشكيل الرُبْد مأكية تعبئة
9 flow chart (flow diagram)	مخطط العمليات	46 bottle-capping machine (capper)	أثيوب أمداء الرُبْد مأكية تشكيل الرُبْد مأكية تعبئة
10 storage tank gauges (<i>Am. gages</i>)	مقاييس صهاريج التخزين	47 cheese machine	أثيوب أمداء الرُبْد مأكية تشكيل الرُبْد مأكية تعبئة
11 control panel	لوحة التحكم	48 rennet vat	أثيوب أمداء الرُبْد مأكية تشكيل الرُبْد مأكية تعبئة
12-48 milk processing area	منطقة تصنيع اللبن	77 Bees and Beekeeping (Apiculture)	النحل وتربية النحل (النحال)
12 sterilizer (homogenizer)	جهاز تعقيم	1-25 bee (honey-bee, hive-bee)	نحلة (نحلة العسل، نحلة الخلية)
13 milk heater; <i>sim.</i> : cream heater	جهاز تسخين اللبن؛ مثله جهاز تسخين القشدة	1, 4, 5 castes (social classes) of bees	طبقات النحل الاجتماعية
14 cream separator	فرازة القشدة	1 worker (worker bee)	شغالة
15 fresh milk tanks	خزانات اللبن الطازج	2 three simple eyes (ocelli)	ثلاث أعين بسيطة
16 tank for sterilized milk	خزان لبن معقم	3 load of pollen on the hind leg	حمل من اللقاح على الساق الخلفية
17 skim milk (skimmed milk) tank	خزان لبن منزوع الدسم	4 queen (queen bee)	المملكة
18 buttermilk tank	خزان المخيض	5 drone (male bee)	ذكر النحل
19 cream tank	خزان القشدة	6-9 left hind leg of a worker	القدم اليسرى الخلفية لإحدى الشغالات
20 fresh milk filling and packing plant	معمل تعبئة وتعليب اللبن الطازج	6 pollen basket	سلة اللقاح/ غبار الطلع
21 filling machine for milk cartons; <i>sim.</i> : milk tub filler	ماكينة تعبئة اللبن في علب كرتون	7 pollen comb (brush)	سشط (فراشة) اللقاح/ غبار الطلع
22 milk carton	علبة لبن من الكرتون	8 double claw	برتن/ مخلب مزدوج
23 conveyor belt (conveyor)	سير ناقل	9 suctorial pad	لبيدة ماصة
24 shrink-sealing machine	ماكينة التغطية وإحكام سد العيوب بالانكماش	10-19 abdomen of the worker	بطن الشغالة
25 pack of twelve in shrink foil	عبوة تحتوي على 12 علبة في رقيقة معدنية	10-14 stinging organs	أعضاء اللدغ
26 ten-litre filling machine	ماكينة تعبئة عبوات سعة 10 لترات	10 barb	شوكة
27 heat-sealing machine	ماكينة إحكام سد الأكياس حرارياً	11 sting	إبرة
28 plastic sheets	أفرخ بلاستيك	12 sting sheath	غمد الإبرة
29 heat-sealed bag	كيس محكم السد حرارياً	13 poison sac	كيس يحتوي على مادة سامة
30 crate	صندوق	14 poison gland	غدة إفراز المادة السامة
31 cream maturing vat	راقود إنضاج القشدة	15-19 stomache-intestinal canal	القناة المعدية المعوية
32 butter shaping and packing machine	ماكينة تشكيل وتعبئة الرُبْد	15 intestine	الأمعاء
33 butter churn, a creamery butter machine for	مخضضة الرُبْد، ماكينة صنع الرُبْد، المقشدة	16 stomach	المعدة
		17 contractile muscle	عضلة قابضة
		18 honey bag (honey sac)	كيس/ جيب العسل

19 oesophagus (esophagus, gullet)	المرئ	<i>Am. beeman</i>)	حجاب واق من النحل
20-24 compound eye	عين مركبة	58 bee veil	جهاز طرد النحل بالدخان
20 facet	عدسة قرنية	59 bee smoker	فقرص عسل طبيعي
21 crystal cone	مخروط بلوري	60 natural honeycomb	فرازة العسل
22 light-sensitive section	قطاع حساس للضوء	61 honey extractor (honey separator)	عسل مصفى
23 fibre (<i>Am. fiber</i>) of the optic nerve	ليفة العصب البصري	62-63 strained honey (honey)	دلو عسل
24 optic nerve	عصب بصري	62 honey pail	مرطبان عسل
25 wax scale	طبقة شمعية	63 honey jar	عسل داخل الفُرص
26-30 cell	خلية	64 honey in the comb	فيلة مشمعة
26 egg	بيضة	65 wax taper	شمعة
27 cell with the egg in it	خلية بها بيضة	66 wax candle	شمع العسل
28 young larva	يرقة صغيرة	67 beeswax	مزهق لمعالجة لدغ النحل
29 larva (grub)	يرقة، يرقاتة	68 bee sting ointment	
30 chrysalis (pupa)	خادرة	78 Wine Growing (Viticulture, Viticulture)	زراعة الكروم
31-43 honeycomb	فُرص العسل	1-21 vineyard area	منطقة زراعة الكرمة
31 brood cell	خلية حضن	1 vineyard using wire trellises for training vines	كروم يستخدم فيه تعريشات من السلك لتعريش الكروم
32 sealed (capped) cell with chrysalis (pupa)	خلية مكمكة السد بداخلها خادرة	2-9 vine (<i>Am. grapevine</i>)	كروم
33 sealed (capped) cell with honey (honey cell)	خلية عسل مكمكة	2 vine shoot	فروع كرمة
34 worker cells	خلايا الشغالات	3 long shoot	نبتة طويلة
35 storage cells, with pollen	خلايا التخزين وبها اللقاح	4 vine leaf	ورقة من أوراق الكرمة
36 drone cells	خلايا ذكور النحل	5 bunch of grapes (cluster of grapes)	عقود عنب
37 queen cell	خلية الملكة	6 vine stem	ساق الكرمة
38 queen emerging from her cell	الملكة وهي تخرج من خليتها	7 post (stake)	ود
39 cap (capping)	غطاء	8 guy (guy wire)	شدادة، حبل/ سلك تثبيت
40 frame	إطار	9 wire trellis	تعريشة سلكية
41 distance piece	قطعة مبادعة	10 tub for grape gathering	دلو لجمع العنب
42 [artificial] honeycomb	فُرص عسل [صناعي]	11 grape gatherer	جامع العنب
43 septum (foundation, comb foundation)	غشاء فاصل/ حاجز	12 secateurs for pruning vines	مقص لتقليم الكروم
44 queen's travelling (<i>Am. traveling</i>) box	صندوق نقل الملكة	13 wine grower (vini-culturist, viticulturist)	زارع الكروم
45-50 beehive, a frame hive (movable-frame hive, movable-comb hive)	خلية النحل، خلية نحل متحركة	14 dossier carrier	حامل سلّة الكروم
45 super (honey super) with honeycombs	جزء علوي قابل للزرع به أفرص العسل	15 dossier (pannier)	سلّة الكروم
46 brood chamber with breeding combs	حجرة الحضن مزودة بأفرص تربية النحل	16 crushed grape transporter	وعاء نقل العنب المعصور
47 queen-excluder	حاجز فصل الملكة	17 grape crusher	غصارة العنب
48 entrance	مدخل، فتحة الدخول	18 hopper	قادوس
49 flight board (alighting board)	لوح الطيران (لوح الهبوط)	19 three-sided flap extension	امتداد قلاب ذو ثلاثة أبعاد
50 window	نافذة	20 platform	منصة
51 old-fashioned bee shed	سفينة تربية نحل طراز قديم	21 vineyard tractor, a narrow-track tractor	جرار الكروم، جرار صغير
52 straw hive (skep), a hive	خلية من القش	79 Wine Cellar	قبو الخمر
53 swarm (swarm cluster) of bees	خشرم (جماعة من النحل)	1-22 wine cellar (wine vault)	قبو، سرداب
54 swarming net (bag net)	شبكة الخشرم	1 vault	برميل الخمر
55 hooked pole	قضيب ذو خفاف	3 wine vat, a concrete vat	راقود الخمر، راقود خرساني
56 apiary (bee house)	محل (بيت النحل)	4 stainless steel vat (<i>also</i> : vat made of synthetic	راقود مصنوع من صلب لا
57 beekeeper (apiarist,	عامل النحل (النحال)		

material)	يصدأ (أيضاً وغاء مصنوع من مادة صناعية)	20-27 vine pests	آفات الكروم	51 sugar beet ceelworm, a nematode (a thread-worm, hairworm)	أنتيفيس البَجَر (دودة خيطية، دودة شعرية)	30 Angoumois grain moth caterpillar inside a grain kernel	يسرّوع الفراشة داخل نواة حبة من الحبوب
5 propeller-type high-speed mixer	خلاط بمروحة عالي السرعة	20 downy mildew, a mildew, a disease causing leaf drop	إرمداد، فطر عفونة الكرم	52 Colorado beetle (potato beetle)	خَنَقَسَاء كلرادو (خَنَقَسَاء البطاطس)	31-42 parasites of man	طفيليات الإنسان
6 propeller mixer	خلاط مَرَوِّد بمروحة/برقأص	21 grape affected with downy mildew	عَيْبٌ مُصَاب الإرمِداد	53 mature larva (grub)	يرقانة ناضجة	31 round worm (maw worm)	الدودة الأسطوانية
7 centrifugal pump	مضخة نايدة	22 grape-berry moth	فَرَأَشَة العَيْب	54 young larva (grub)	يرقانة صغيرة	32 female	أنثى
8 stainless steel sediment filter	مرشح رواسب مصنوع من صلب لا يصدأ	23 first-generation larva of the grape-berry moth (Am. grape worm)	يرقانة الجيل الأول لفراشة العنب	55 eggs	بيض	33 head	رأس
9 semi-automatic circular bottling machine	ماكينة دوارة نصف آلية لتعبئة الزجاجات	24 second-generation larva of the grape-berry moth (Am. grape worm)	يرقانة الجيل الثاني لفراشة العنب	81 House Insects, Food Pests, and Parasites	الحشرات المنزلية وآفات الطعام والطفيليات	34 male	ذكر
10 semi-automatic corking machine	ماكينة سدادات فلبينية نصف آلية	25 chrysalis (pupa)	خادرة	1-14 house insects	الحشرات المنزلية	35 tapeworm, a flatworm	دودة شريطية/خيطية
11 bottle rack	رفّ الزجاجات	26 root louse, a grape phylloxera	فَلَكْمِبَرَة الكَرْم	1 lesser housefly	ذبابة منزلية صغيرة	36 head, a suctorial organ	رأس، عضو ماص
12 cellarer's assistant	عامل القبو، مساعد مسئول القبو	27 root gall (knotty swelling of the root, nodosity, tuberosity)	عَفْصَة الجذور (تورم عقدي للساق)	2 common housefly	ذبابة منزلية صغيرة	37 sucker	مصاص، عضو المص
13 bottle basket	سلة الزجاجات	28 brown-tail moth	لبيلة البقول	3 chrysalis (pupa, co-arcate pupa)	الذباب المنزلية الشائعة خادرة (عذراء مستورة)	38 crown of hooks	تاج من الخطافات
14 wine bottle	زجاجة خمر	29 caterpillar	سُرْفَة، أسرود	4 stable fly (biting housefly)	ذبابة الإسطبل (ذبابة منزلية لادغة)	39 bug (bed bug, Am. chinch)	البقّ (بق الفراش)
15 wine jug	دورق الخمر	30 batch (cluster) of eggs	سُرْفَة، أسرود	5 trichotomous antenna	فَرَن استشعار ثلاثي	40 crab louse (a human louse)	قمل العانة (قمل الإنسان)
16 wine tasting	تذوق جودة الخمر	31 hibernation cocoon	عنقود بيض	6 wood louse (slater, Am. sow bug)	الجدجُد صرّار الليل المنزلي	41 clothes louse (body louse, a human louse)	قمل الملابس (قمل الجسم، قمل الإنسان)
17 head cellarman	رئيس عامل القبو	32 woolly apple aphid (American blight), an aphid	شُرْقَة الإسباب الشتوي	7 house cricket	الجَدَجُد صرّار الليل المنزلي	42 flea (human flea, common flea)	برغوث شائع
18 cellarman	عامل القبو	33 gall caused by the woolly apple aphid	أرقة التفاح القطبية	8 wing with stridulating apparatus (stridulating mechanism)	جناح ذو آلية إصدار الصوت	43 setse fly	ذبابة تسي تسي
19 wineglass	كأس خمر	34 woolly apple aphid colony	عَفْصَة أحدثتها أرقة التفاح القطبية	9 house spider	العنكبوت المنزلي	44 malaria mosquito	بغوضه الملاريا
20 inspection apparatus [for spot-checking samples]	جهاز الفحص [للعينات الفورية]	35 San-José scale, a scale insect (scale louse)	مستعمرة أرقة التفاح القطبية	10 spider's web	شبكة العنكبوت	82 Forest Pests	الآفات الحراجية
21 horizontal wine press	عصارة خمور أفقية	36 larvac (grubs) [male elongated, female round]	اليرقات [المذكورة مستطيلة المؤنثة مستديرة]	11 earwig	أبو مقص	1 cockchafer (May bug), a lamellicorn	الدودة البيضاء
22 humidifier	جهاز ضبط الرطوبة في القبو	37-55 field pests	آفات الحقل	12 caudal pincers	مقص ذبلي/ذنب	2 head	رأس
80 Garden and Field Pests	آفات الحدائق والحقول	37 click beetle, a snapping bug (Am. snapping bug)	الخَنَقَسَاء النطاطة	13 clothes moth, a moth	عثة الملابس	3 antenna (feeler)	فَرَن استشعار
1-19 field pests	آفات الفلاحة	38 wireworm, larva of the click beetle	دودة السلك، يرقانة الخنقساء النطاطة	14 silverfish (Am. slicker), a bristletail	لاجسة السكر	4 thoracic shield (prothorax)	درع ذوري
1 gipsy (gypsy) moth	فَرَيَة إسفنجية	39 flea beetle	برغوث البساتين	15-30 food pests (pests to stores)	حشرات الطعام (حشرات المخازن)	5 scutellum	صفحة حُرْشَفِيَّة، حُرْشَفَة الأرجل
2 batch (cluster) of eggs	عنقود بيض	40 Hessian fly, a gall midge (gall gnat)	ذبابة هيس، الذبابة المبيدة	15 cheese fly	ذبابة الجبن	6 front leg	رجل أمامية
3 caterpillar	سُرْفَة، أسرود	41 larva (grub)	يرقانة	16 grain weevil (granary weevil)	سوسة الحنطة، سوسة الحبوب	7 middle leg	رجل وسطية
4 chrysalis (pupa)	خادرة	42 turnip moth, an earth moth	فَرَأَشَة اللغث	17 cockroach (black beetle)	صرصور (خنقساء سوداء)	8 back leg	رجل خلفية
5 small ermine moth, an ermine moth	فَرَأَشَة التفاح	43 chrysalis (pupa)	خادرة	18 meal beetle (meal worm beetle, flour beetle)	خنقساء الدقيق	9 abdomen	المعدة
6 larva (grub)	يرقانة	44 cutworm, a caterpillar	دودة قارضة، سُرْفَة	19 spotted bruchus	سوسة منقطعة، خنقساء سوسية منقطعة	10 elytron (wing case)	غمد
7 tent	خيمة	45 beet carrion beetle	خنقساء الشونذر الكاملة، درقة الشونذر	20 larva (grub)	يرقانة	11 membranous wing	جناح غشائي
8 caterpillar skeletonizing a leaf	سُرْفَة/أسرود يأتي على ورقة شجر	46 larva (grub)	يرقانة	21 chrysalis (pupa)	خادرة (عذراء)	12 cockchafer grub, a larva	يرقانة الدودة البيضاء
9 fruit-surface-eating tortrix moth (summer fruit tortrix moth)	عفاصة، فتالة	47 large cabbage white butterfly	فَرَأَشَة الكرفب الكبيرة	22 leather beetle (hide beetle)	حشرة الطيثار	13 chrysalis (pupa)	خادرة (عذراء)
10 appleblossom weevil, a weevil	خنقساء التفاح	48 caterpillar of the small cabbage white butterfly	سُرْفَة فَرَأَشَة الكرفب الصغيرة	23 yellow meal beetle	خنقساء الجريش الصفراء	14 processionaly moth, a nocturnal moth (night-flying moth)	فَرَيَة البلوط الجزائرية، فَرَأَشَة لبيلة
11 punctured, withered flower (blossom)	زهرة ذابلة	49 brown leaf-eating weevil, a weevil	سوسة ورق الشجر	24 chrysalis (pupa)	خادرة (عذراء)	15 moth	فراشة
12 hole for laying eggs	حفرة لوضع البيض	50 feeding site	مكان التغذية	25 cigarette beetle (tobacco beetle)	خنقساء التبغ	16 caterpillars in procession	يسرّوع جزار
13 lackey moth	فَرَيَة نصطربا			26 maize billbug (corn weevil)	سوسة الذرة	17 nun moth (black arches moth)	فَرَيَة الراهية
14 caterpillar	سُرْفَة، أسرود			27 one of the Cryptolestes, a grain pest	أفة حبوب	18 moth	فراشة
15 eggs	بيض			28 Indian meal moth	فَرَأَشَة الدقيق الهندية	19 eggs	بيض
16 winter moth, a geometrid	أرغفية شتوية			29 Angoumois grain moth (Angoumois moth)	فَرَأَشَة حبوب الانجومويز	20 caterpillar	يسرّوع
17 caterpillar	سُرْفَة، أسرود					21 chrysalis (pupa) in its cocoon	خادرة بداخل شرفتها
18 cherry fruit fly, a borer	ذبابة الكرز					22 typographer beetle, a bark beetle	خنقساء القلف/اللحاء
19 larva (grub, maggot)	يرقانة					23-24 galleries under the bark	دهاليز أسفل اللحاء

23 egg gallery	دهليز البيض	17 tray	صينية	electric motor		lumberman, timber-jack) turning (<i>Am.</i> canting) timber	
24 gallery made by larva	دهليز صنفته اليرقات	18 spray gun	مسدس الرش	54 bag filter	مرشح الأكياس		
25 larva (grub)	يرقات	19 twist grip (control grip, handle) for regulating the jet	قبضة لتنظيم النفاث	55 bagging nozzle	فوهة تعبئة الأكياس		
26 beetle	خنفساء	20 finger guard	وقاء الإصبع	56 dedusting screen (dust removing screen)	غزبال فصل الأتربة	19 bole (tree trunk, trunk, stem)	جذع شجرة
27 pine hawkmoth, a hawkmoth	أبو الهول الصنوبري	21 control lever (operating lever)	وِقَاء الإصبع ذراع التشغيل	57 water canister [containing water for spraying]	وعاء الماء (يحتوى على ماء الرش)	20 feller numbering the logs	قاطع الخشب يرقم زائد الأشجار
28 pine moth, a geometrid	قرية الصنوبر	22 spray tube	أثيوبية الرش	58 spray unit	وحدة الرش	21 steel tree calliper (caliper)	قدم حشب معدنية
29 male moth	فراشة ذكر	23 cone nozzle	فوهة مخروطية	59 conveyor unit with mixing screw	وحدة نقالة ذات برغي خلط	22 power saw (motor saw) cutting a bole	مشآر كهربائي يقطع جذع شجرة
30 female moth	فراشة أنثى	24 hand spray	رشاش يدوي	60 container for disinfectant powder with dosing mechanism	حاوية المسحوق المطهر ذات آلية رش جرعات محددة	23 safety helmet with visor and ear pieces	خوذة أمان مزودة بواقعي للعينين والأذنين
31 caterpillar	يسروع	25 plastic container	حاوية من البلاستيك	61 castor	دولاب صغير	24 annual rings	حلقات تحديد عمر الشجرة
32 chrysalis (pupa)	خادرة (عدراء)	26 hand pump	مضخة يدوية	62 mixing chamber	غرفة خلط محلول الرش	25 hydraulic felling wedge	إسفين قطع هيدرولي
33 oak-gall wasp, a gall wasp	زنبور عصفه البلوط	27 pendulum spray for hop growing on slopes	الرش البنديولي لزراعة حشيشة الدينار على المنحدرات			26 protective clothing [orange top, green trousers]	لباس واق [قميص برتقالي وسروال أخضر]
34 oak gall (oak apple), a gall	عصفه البلوط	28 pistol-type nozzle	المسدسات			27 felling with a power saw (motor saw)	قطع الشجر بمشآر كهربائي
35 wasp	زنبور	29 spraying tube	فوهة سنسبية النوع			28 undercut (notch, throat, gullet, mouth, sink, kerf, birdsmouth)	ثلم قطع الشجرة
36 larva (grub) in its chamber	يرقاته في حجرتها	30 hose connection	أثيوبية الرش			29 back cut	قطع خلفي
37 beech gall	عصفه العرمان/الزان	31 tube for laying poisoned bait	وصلة الخرطوم			30 sheath holding felling wedge	غمد إسفين القطع
38 spruce-gall aphid	أرقة عصفه الراتنجيات	32 fly swat	أثيوب رش	84 Forestry I	الحراجة (I)	31 log	زائد
39 winged aphid	أرقة مجنحة	33 soil injector (carbon disulphide, <i>Am.</i> carbon disulfide, injector) for killing the vine root louse	محقن التربة لقتل آفات جذر الكروم	1-34 forest, a wood	غاية	32 free-cutting saw for removing underwood and weeds	مشآر القطع الحر لإزالة الشجيرات النامية أسفل الأشجار الكبيرة والنباتات الشيطانية
40 pineapple gall	عصفه الأناناس	34 foot lever (foot pedal, foot treadle)	مدبنة	1 ride (aisle, lane, section line)	طريق (غير معبدة عادة)	33 circular saw (or activated blade) attachment	وصلة مشآر دوار
41 pine weevil	سوسة الصنوبر	35 gas tube	مدبنة	2 compartment [section]	قبيلة [قطاع]	34 power unit (motor)	وحدة الطاقة (موتور)
42 beetle (weevil)	خنفساء (سوسة)	36 mousetrap	محقن التربة لقتل آفات جذر الكروم	3 wood haulage way, a forest track	طريق النقل داخل الغابة	35 canister of viscous oil for the saw chain	حاوية زيت تزيق سلسلة المشآر
43 green oak roller moth (green oak tortrix), a leaf roller	فتالة، عفاصة	37 vole and mole trap	مقبض خرطوم	4-14 clear-felling system	نظام قطع الأشجار	36 petrol canister (<i>Am.</i> gasoline canister)	حاوية البنزين
44 caterpillar	يسروع	38 mobile orchard sprayer, a wheelbarrow sprayer (carriage sprayer)	دواسة	4 standing timber	أشجار منتصبة	37 felling of small timber (of small-sized thinings) (thinning)	قطع شجرة صغيرة
45 moth	فراشة	39 spray tank		5 underwood (underbrush, undergrowth, brushwood, <i>Am.</i> brush)	أجمة		
46 pine beauty	دودة الصنوبر	40 screw-on cover		6 seedling nursery, ■ tree nursery	مشتل شجيرات		
47 caterpillar	يسروع	41 direct-connected motor-driven pump with petrol motor		7 deer fence (fence), ■ wire netting fence (protective fence for seedlings); <i>sim.</i> : rabbit fence	سياج لحماية الشتلات (سياج)		
48 moth	فراشة	42 pressure gauge (<i>Am.</i> gage) (manometer)		8 guard rail	قضيب واق		
		43 plunger-type knapsack sprayer		9 seedlings	شتلات		
83 Pest Control	مكافحة الآفات	44 spray canister with pressure chamber		10-11 young trees	أشجار صغيرة		
1 area spraying	الرش النطاقي	45 piston pump lever		10 tree nursery after transplanting	مشتل أشجار بعد نقل وغرس الأشجار		
2 tractor-mounted sprayer	جهاز رش محمول على جرار	46 hand lance with nozzle		11 young plantation	نبات صغير		
3 spray boom	ذراع الرش	47 semi-mounted sprayer		12 young plantation after brashing	نبات صغير بعد التشبيب		
4 fan nozzle	فوهة الرصاص	48 vineyard tractor		13 clearing	أرض تم إخلالها		
5 spray fluid tank	خزانة سائل الرش	49 fan		14 tree stump (stump, stub)	جدل/أرومة الشجرة		
6 foam canister for blob marking	حاوية الرغوة	50 spray fluid tank		15-37 wood cutting (timber cutting, tree felling, <i>Am.</i> lumbering)	قطع الأشجار		
7 spring suspension	تعليق نابضي	51 row of vines		15 timber skidded to the stack (stacked timber, <i>Am.</i> yarded timber)	قطع حشب مكدسة		
8 spray	رزاز	52 dressing machine (seed-dressing machine) for dry-seed dressing (seed dusting)		16 stack of logs, one cubic metre (<i>Am.</i> meter) of wood	رصمة من زائد الشجر، متر مكعب من الحشب		
9 blob marker	أداة التعليم	53 dedusting fan (dust removal fan) with		17 post (stake)	عرق حشب		
10 foam feed pipe	أثيوبية التغذية بالرغوة			18 forest labourer (woodsman, <i>Am.</i> logger, lumberer, lumberjack,	الخطاب وهو يخرط الشجر		
11 vacuum fumigator (vacuum fumigation plant) of a tobacco factory	وحدة التطهير بالتعريض للدخان في مصنع تبغ						
12 vacuum chamber	غرفة خوائية						
13 bales of raw tobacco	بالات التبغ الخام						
14 gas pipe	أثيوبية الغاز						
15 mobile fumigation chamber for fumigating nursery saplings, vine layers, seeds, and empty sacks with hydrocyanic (prussic) acid	غرفة تبخير متنقلة لتطهير شجيرات المشاتل والكرام والبيذور والجالات الخالية بحمص الهيدروسيانك.						
16 gas circulation unit	وحدة تدوير الغاز						

logging	مطرفة ترقيم دوارة	ing, <i>Am.</i> stillhunting) in the game preserve	المخصصة للصيد
12 revolving die hammer (marking hammer, marking iron, <i>Am.</i> marker)	مطرفة ترقيم دوارة	1 huntsman (hunter)	صياد
13 power saw (motor saw)	ميشار كهربائي (مشار بموتور)	2 hunting clothes	لباس الصيد
14 saw chain	سلسلة المشار	3 knapsack	حقية ظهرية
15 safety brake for the saw chain, with finger guard	مكبح أمان سلسلة المشار له وقاء للإصبع	4 sporting gun (sporting rifle, hunting rifle)	بنديقية صيد
16 saw guide	دليل المشار	5 huntsman's hat	قبعة الصياد
17 accelerator lock	قفل المسارع	6 field glasses, binoculars	منظار ميداني، ناظور
18 snedding machine (trimming machine, <i>Am.</i> knotting machine, limbing machine)	ماكينة تشذيب	7 gun dog	كلب صيد لجلب القنص
19 feed rolls	درايفيل الإقمام	8 track (trail, hoofprints)	أثر (أثار حافر)
20 flexible blade	نصل مرن	9-12 hunting in the rut- ting season and the pairing season	الدورة المزوية والمزاوج
21 hydraulic arm	ذراع هيدرولي	9 hunting screen (screen, <i>Am.</i> blind)	سِخار الصيد
22 trimming blade	نصل التشذيب	10 shooting stick (shoot- ing seat, seat stick)	مقعد الصيد
23 debarking (barking, bark stripping) of boles	نزع لحاء جذوع الشجر	11 blackcock, displaying	طائر الشجورود
24 feed roller	درايفيل الإقمام	12 rutting stag	أيل في الدورة المزوية
25 cylinder trimmer	أداة تشذيب أسطوانية	13 hind, grazing	أيلة تأكل الكلا
26 rotary cutter	قاطع دوّار	14-17 hunting from a raised hide (raised stand)	الصيد من مخبأ مرتفع
27 short-haul skidder	عربة نقل للمسافات القصيرة	14 raised hide (raised stand, high seat)	مخبأ مرتفع (منصة مرتفعة، مقعد مرتفع)
28 loading crane	عربة نقل للمسافات القصيرة	15 herd within range	فقيع في مرمى القنص
29 log grips	وش التحميل	16 game path (<i>Am.</i> run- way)	ممر الطرائد
30 post	عمود ساند	17 roebuck, hit in the shoulder and killed by a finishing shot	حيوان الروّ، أصيب بطلقة أخرى في الكتف وأجهز عليه بطلقة
31 Ackermann steering system	نظام توجيه أكريمان	18 phaeton	مركبة الفيتون
32 log dump	مخزون خشب	19-27 types of trapping	أنواع الفخاخ
33 number (identification number)	رقم الرنّد	19 trapping of small predators	الإيقاع بالحيوانات المفترسة الصغيرة في الفخ
34 skidder	عربة إنزالاقية	20 box trap (trap for small predators)	فخ صندوقي
35 front blade (front plate)	النصل الأمامي	21 bait	طعم
36 crush-proof safety bon- net (<i>Am.</i> safety hood)	كبيوت أمان ضد الكسر	22 marten, a small predator	حيوان الدلق أو السُور
37 Ackermann steering system	نظام توجيه أكريمان	23 ferretting (hunting rabbits out of their warrens)	صيد الأرانب بالاستعانة بابين مقرص
38 cable winch	وش كيبلي	24 ferret	ابن مقرص، الثمس
39 cable drum	أسطوانة الكبل	25 ferreter	صائد الأرانب بالاستعانة بابين مقرص
40 rear blade (rear plate)	النصل الخلفي	26 burrow (rabbit burrow, rabbit hole)	جحر، وجار
41 boles with butt ends held off the ground	جذوع أشجار وأطرافها الخلفية مرفوعة عن الأرض	27 net (rabbit net) over the burrow opening	شبكة فوق فتحة الجحر
42 haulage of timber by road	نقل الخشب بالعربات برّياً	28 feeding place for game (winter feeding place)	مكان إطعام خاص بالصيد
43 tractor (tractor unit)	جرّار	29 poacher	صياد بصيد في خبيّة خاصة بدون إذن صاحبها
44 loading crane	وش التحميل	30 carbine, a short rifle	القرينة بنديقية قصيرة
45 hydraulic jack	مرفاع هيدرولي	31 boar hunt	صيد الخنازير البرية
46 cable winch	وش كيبلي	32 wild sow (sow, wild boar)	خنزير بري
47 post	عمود ساند		
48 bolster plate	لوحة استناد		
49 rear bed (rear bunk)	مرقد خلفي		

القنص

أنواع الصيد
اقتفاء الأثر في الأرض

33 boarhound (hound, hunting dog; <i>collectively:</i> pack, pack of hounds)	كلب صيد الخنازير البرية	6 pistol grip	قبضة مسدس
34-39 beating (driving, hare hunting)	إثارة الطرائد من مخابئها (صيد الأرانب البرية)	7 small of the butt	الجزء المستدق من الدبشيك/ الإخض
34 aiming position	وضع التصوير	8 safety catch	سقاطة الأمان
35 hare, furred game (ground game)	أرنب بري، صيد فرائي، صيد أرضي	9 lock	الترباس
36 retrieving	استرجاع القرينة للصيد	10 trigger guard	واقى الزناد
37 beater	صياد بجول أرجاء الغابة مفيراً للفراش من مخابئها	11 second set trigger (firing trigger)	زناد الإطلاق
38 bag (kill)	عربة لصل الحيوانات المصطادة	12 hair trigger (set trigger)	زناد شعري
39 cart for carrying game	عربة لصل الحيوانات المصطادة	13 foregrip	قبضة أمامية
40 waterfowling (wild- fowling, duck shooting, <i>Am.</i> duck hunting)	صيد الطيور المائية (صيد البط)	14 butt plate	كتلة الدبشيك/الإخض
41 flight of wild ducks, winged game	سرب من البط البري، صيد من الطيور	15 cartridge chamber	خجرة الطلقة
42-46 falconry (hawking)	الصيد بالصفور	16 receiver	المستقبل
42 falconer	الصفار	17 magazine	المخزن
43 reward, a piece of meat	مكافأة، قطعة لحم	18 magazine spring	ناض المخزن
44 falcon's hood	قلنسوة الصقر	19 ammunition (cartridge)	ذخيرة (خرطوش)
45 jess	قيّد البازي	20 chamber	خجرة
46 falcon, hawk, a male hawk (tiercel) swooping (stooping) on a heron	صقر/باز ينقض على طائر مالك الحزين	21 firing pin (striker)	إبرة ضرب النار (الضارب)
47-52 shooting from a butt	القنص من داخل أرومة	22 bolt handle (bolt lever)	ذراع الترياس
47 tree to which birds are lured	شجرة تنغوى بها الطيور كفخم	23 triple-barrelled (triple- barreled) rifle, a self- cocking gun	بنديقية ذات ثلاث مواشير/ سيطانات، سلاح ذاتي التعمير
48 eagle owl, a decoy bird (decoy)	بومة صفحابة، شرك على شكل طائر	24 reversing catch; <i>in var- ious guns:</i> safety catch	حاجس سقاطة الأمان، في أسلحة متنوعة سقاطة الأمان
49 perch	مختم الطيور	25 sliding safety catch	سقاطة أمان منزلقة
50 decoyed bird, a crow	طائر يقع في الشرك، غراب	26 rifle barrel (rifled barrel)	ماسورة البندقية (سبطانة محزرة)
51 butt for shooting crows or eagle owls	أرومة لقنص الغربان والبوم الصخاب	27 smooth-bore barrel	ماسورة مسأء الجوف
52 gun slit	فتحة إبراز البندقية	28 chasing	نقوش زينية
		29 telescopic sight (rifle- scope, telescope sight)	منظار تليسكوبي (ناظور البندقية)
		30 graticule adjuster screws	براغي ضبط العينية
		31-32 graticule (sight graticule)	سداة العينية
		31 various graticule systems	أنظمة عينية متنوعة
		32 cross wires (<i>Am.</i> cross hairs)	السلكان المتقاطعان
		33 over-and-under shotgun	بنديقية صيد ذات ماسورتين
		34 rifled gun barrel	ماسورة/سبطانة بنديقية محزرة
		35 barrel casing	غلاف الماسورة/السبطانة
		36 rifling	حزوز
		37 rifling calibre (<i>Am.</i> caliber)	عيار الحزرة
		38 bore axis	محور جوف الماسورة/ السبطانة
		39 land	خند
		40 calibre (bore diameter, <i>Am.</i> caliber)	العيار (قطر الجوف)
		41-48 hunting equipment	معدات الصيد
		41 double-edged hunting knife	سكين صيد ذو نصلين
		42 [single-edged] hunting knife	سكين صيد [ذو نصل واحد]
		43-47 calls for luring game (for calling game)	أدوات محاكاة أصوات الطرائد لاجتذابها

الكفلة

الدبشيك، الإخض
وَجَنَّة [على الجانب الأيسر]
حلقة الصالة

game)	أداة مُحَاكَاة صوت الرُوء	5-11 antlers	القرون	47 brush (tail)	ذَيْلُ	3 semi-oval barrel for transporting fish	برُمَّيل شَبْه بِيضَاوي لنقل السمك
43 roe call	أداة مُحَاكَاة صوت الأرانب	5 burr (rose)	مَثَبَاتُ القرون بالجبهة (وردة)	48 badger, (f.) sow	الغُرْبِيرُ (الأنثى أنثى الغُرْبِيرُ)	4 vat	ذَنْ، وعاء ضخم
44 hare call	أداة مُحَاكَاة صوت الأرانب	6 brow antler (brow tine, brow point, brow snag)	قَرْنُ الحاجب	49 tail	ذَيْلُ	5 trellis in the overflow	تَعْرِيشَة في فيضان الماء
45 quail call	أداة مُحَاكَاة صوت السمانى	7 brow antler (bay antler, bay, bez tine)	قَرْنُ بارز	50 paws	مخالب	6 trout pond; <i>sim.</i> : carp pond, a fry pond, fattening pond, or cleansing pond	حوض تربية سمك الأطروط (مئله حوض تربية سمك الشبوط، حوض زريعة السمك)
46 stag call	أداة مُحَاكَاة صوت الأيل	8 royal antler (royal, royal)	قَرْنُ ملكي	51 wild boar, (m.) boar, (f.) wild sow (sow), (y.) young boar	خنزير بَرِّي (أنثى خنزيرة، أنثى الروث، الصغير خنوص)	7 water inlet (water supply pipe)	أَنْبُوب دخول/إمداد الماء
47 partridge call	فَحْ قَوْسَى، فَحْ فِكِي	9 surroyal antlers (surroyals)	قَرْنُ إضافي	52 bristles	هَلْبُ	8 water outlet (outlet pipe)	أَنْبُوب خروج الماء
48 bow trap (bow gin), a jaw trap	خروطوش طلقات صغيرة	10 point (time)	طرف القَرْنِ المدبب	53 snout	نَابُ	9 monk	صندوق غُرْبَلَة (مُوتَلَك)
49 small-shot cartridge	غلاف من الورق المغقوى	11 beam (main trunk)	فروع قرون رئيسي	54 tusk	دِرْعُ الخنزير	10 screen	غُرْبَالُ
50 cardboard case	حَشْوَة من الطلقات الصغيرة	12 head	رَأْسُ	55 shield	جِلْد الخنزير	11-19 hatchery	مكان تربية الأسماك
51 small-shot charge	حَشْوَة من اللباد	13 mouth	حَظْمُ (فم)	56 hide	جِلْد الخنزير	11 stripping the spawning pike (seed pike)	استخلاص البيض من سمكة الكراكي
52 felt wad	بارود عديم الدخان [نوع مختلف بارود أسود]	14 lammer (tear bag)	كيس الدموع	57 dew claw	ذَيْلُ	12 fish spawn (spawn, roe, fish eggs)	بَيْضُ السمكة
53 smokeless powder (different kind: black powder)	رِصَاصَة، طلقة	15 eye	عين	58 tail	أرنب بَرِّي	13 female fish (spawner, seed fish)	سمكة
54 cartridge	رِصَاصَة بغلاف كامل	16 ear	أذن	59 hare, (m.) buck, (f.) doe	عين	14 trout breeding (trout rearing)	تربية سمك الأطروط
55 full-jacketed cartridge	جُوف من الرصاص اللين	17 shoulder	كتف	60 eye	أذن	15 Californian incubator	حَضَانَة بَيْضُ السمك
56 soft-lead core	حَشْوَة من البارود	18 loin	خاصرة	61 ear	ذَيْلُ قصير	16 trout fry	زريعة سمك الأطروط
57 powder charge	كبسولة المُغْبِرِ	19 scut (tail)	ذَيْلُ قصير (ذَيْلُ)	62 scut (tail)	رَجُلُ خلفية	17 hatching jar for pike	وعاء فقس بَيْضُ السمك
58 detonator cap	كبسولة الفدح	20 lump	رَدْف، كَفَل	63 hind leg	رَجُلُ أمامية	18 long incubation tank	خَزَان حَضَنُ بَيْضُ السمك لفترة طويلة
59 percussion cap	بوق الصيد	21 leg (haunch)	فَحْدُ (التيه)	64 foreleg	أرنب	19 Brandstetter egg-counting board	عداد بَيْضُ السمك طراز "براند ستر"
60 hunting horn	طاقم أدوات تنظيف	22 hind leg	رَجُلُ خلفية	65 rabbit	طائر الشَّحْرور	20-94 angling	صَيْدُ السمك بالصَّارَة
61-64 rifle cleaning kit	البيندقية	23 dew claw	الزُّمْعَة	66 blackcock	ذَيْلُ	20-31 bottom fishing (coarse fishing)	الصَيْدُ من قاع البحر
61 cleaning rod	قضيب التنظيف (المُغْرَاطُ/الحرابي)	24 hoof	حافر	67 tail	ريش معقوف	20 line shooting	قَذْفُ الصَّارَة
62 cleaning brush	فرشاة التنظيف	25 foreleg	رَجُلُ أمامية	68 falcate (falcated) feathers	طائر مَهْوُوج البيندق	21 coils	ملفات خيط الصَّارَة
63 cleaning tow	مسألة كتانية للتنظيف	26 flank	جَنْبُ، خاصرة	69 hazel grouse (hazel hen)	طائر الحَيْحَلِ	22 cloth (rag) or paper	خَرْقَة قماش أو ورقة
64 pull-through (Am. pull-thru)	سيخ التسليك	27 collar (rutting mane)	الشعر المُطَوَّق لرقبة الأيل	70 partridge	طائر الحَيْحَلِ	23 rod rest	سند الصَّارَة
65 sights	المُسَدَّدة، المُوجَّه، الناشران	28-39 roe (roe deer)	الرُوءُ	71 horseshoe (horseshoe marking)	حَدْوَة حِصَان (علامة)	24 bait tin	علبة طعم الصيد
66 notch (sighting notch)	المُسَدَّدة، المُوجَّه، الناشران	28 roebuck (buck)	ذَكَرُ الرُوءِ (غزال الرُوءِ)	72 wood grouse (capercaille)	طَهْوُوج الغابة	25 fish basket (creel)	سلة جمع السمك المُسْتَاذ
67 back sight leaf	فتحة التسديد/التوجيه	29-31 antlers (horns)	القرون	73 beard	لحية	26 fishing for carp from a boat	صَيْدُ سمك الأطروط من قارب
68 sight scale division	فتحة التسديد/التوجيه	29 burr (rose)	مَثَبَاتُ القرون بالجبهة (وردة)	74 axillary marking	علامة إبطية	27 rowing boat (fishing boat)	قارب تحديف (قارب صيد)
69 back sight slide	ورقة المُسَدَّدة الخلفية	30 beam with pearls	فروع قرون رئيسي وبه بوادر القرون	75 tail (fan)	ذَيْلُ (مروحة)	28 keep net	شبكة صيد حاجزة
70 notch [to hold the spring]	مُرْلاَق المُسَدَّدة الخلفية	31 point (tine)	طرف القَرْنِ المدبب	76 wing (pinion)	جناح (جنيح سفلي)	29 drop net	شبكة صيد إسقاطية
71 front sight (foresight)	نقرة [لتثبيت النابض]	32 ear	أذن	77 common pheasant, a pheasant, (m.) cock pheasant (pheasant cock), (f.) hen pheasant (pheasant hen)	طائر التَّدرَج (ذَكَرُ التَّدرَج، أنثى التَّدرَج)	30 pole (punt pole, quant pole)	شُخْرُورَة (عصا دفع القارب)
72 sight	المُسَدَّدة، المُوجَّه، الناشران	33 eye	عين	78 plumicorn (feathered ear, ear tuft, ear, horn)	أذن مَرِيَّشَة (قَرْنُ)	31 casting net	شبكة صيد
73 ballistics	الناشران	34 doe (female roe), a female fawn or a barren doe	أنثى الرُوءِ، أنثى غزال صغيرة أو أنثى عاقر	79 wing	جناح	32 two-handed side cast with fixed-spool reel	إلقاء صسارة ذات بكرة ثابتة
74 azimuth	الناشران	35 loin	الخاصرة	80 tail	ذَيْلُ	33 initial position	جانبيا بكتنا اليمين
75 angle of departure	زاوية الخروج من المأسورة	36 rump	رَدْف، كَفَل	81 leg	رَجُلُ	34 point of release	نقطة الإطلاق
76 angle of elevation	زاوية الارتفاع	37 leg (haunch)	وَرَكُ (التيه)	82 spur	شُوكَة	35 path of the rod tip	مسار طرف الصَّارَة
77 apex (zenith)	أعلى نقطة على منحنى المنسار	38 shoulder	كُتْفُ	83 snipe	طائر الشُّقْبِ	36 trajectory of the baited weight	مسار النقر المُحْصَلُ بالطعم
78 angle of descent	زاوية السقوط	39 fawn, (m.) young buck, (f.) young doe	ولد الرُوءِ، ذَكَرُ غلبى، أنثى غلبية	84 bill (beak)	مِيقَارُ	89 Fish Farming (fish culture, pisciculture) and Angling	تَرْبِيَة الأسماك والصَيْدُ بالصَّارَة
79 ballistic curve	منحنى سير المقذوف	40-41 fallow deer	ذَكَرُ الأيلِ الأَسْمَرِ ذو قرون راجية، الأنثى خلبية	89 Fish Farming (fish culture, pisciculture)	تَرْبِيَة الأسماك (تربية الأسماك)	1-19 fish farming (fish culture, pisciculture)	المُغْرَاعُ السَّمَكِيَة (تربية الأسماك)
88 Game	القَنْصُ/الطَّرَادُ	41 palm	راحة القَرْنِ	1 cage in running water	قفص في ماء جار	2 hand net (landing net)	شبكة صيد حديدية
1-27 red deer	الأيل الأحمر	42 red fox, (m.) dog, (f.) vixen, (y.) cub	الثعلب الأحمر (ذَكَرُ ثعلب، أنثى ثعلبة، الصغير شَيْل)	2 hand net (landing net)	شبكة صيد حديدية		
1 hind (red deer), a young hind or a dam; collectively: antlerless deer, (y.) calf	الأيلة، أيلة صغيرة، اسم الجمع الأيل عديم القرون، (الصغير) صغير الأيل	43 eyes	عيان				أبوات الصيد
2 tongue	لسان	44 ear	أذن				زردية صيد
3 neck	رقبة	45 muzzle (mouth)	حَظْمُ (فم)				سكين تقطيع الشرائح
4 rutting stag	أيل في الدَّورَة الذَّرْوِيَة	46 pads (paws)	مخالب				سكين سمك

35-44 watermill	طاحونة مائية
overshot mill wheel (high-breast mill wheel), a mill wheel (waterwheel)	ساقية تدار بالدفع العلوي
36 bucket (cavity)	دلو
37 middleshot mill wheel (breast mill wheel)	ساقية تدار بالدفع الأوسط
38 curved vane	ريشة منحنية
39 undershot mill wheel	ساقية تدار بالدفع السفلي
40 flat vane	ريشة مسطحة
41 headrace (discharge flume)	مجرى الماء الرئيسي
42 mill weir	سد الطاحونة
43 overfall (water overfall)	سقوط الماء الفائض
44 millstream (millrace, Am. raceway)	تيار مائي داقد يدير الطاحونة
92 Malting and Brewing I	تخمير الملت وتصنيع الجعة (I)
1-41 preparation of malt (malting)	إعداد الملت (تخمير الملت)
1 malting tower (maltings)	برج تخمير الملت (التخمير)
2 barley hopper	قادوس الشعير
3 washing floor with compressed-air washing unit	طايق غسل مزود بوحدّة غسل تعمل بالهواء المضغوط
4 outflow condenser	مكثف الدفق
5 water-collecting tank	خزان تجمع الماء
6 condenser for the steep liquor	مكثف مطلول النقع
7 coolant collecting plant	معدّل تجمع المبرد
8 steeping floor (steeping tank, dressing floor)	طايق النقع (خزان النقع)
9 cold water tank	خزان الماء البارد
10 hot water tank	خزان الماء الساخن
11 pump room	خجرة المضخة
12 pneumatic plant	معدّل يعمل بالهواء المضغوط
13 hydraulic plant	معدّل هيدرولي
14 ventilation shaft (air inlet and outlet)	عمود التهوية (مدخل ومخرج الهواء)
15 exhaust fan	مروحة طاردة
16-18 kilning floors	طايق التجفيف الثوروي
16 drying floor	طايق تجفيف
17 burner ventilator	جهاز تهوية التوقد
18 curing floor	طايق المعالجة بالتخمير
19 outlet duct from the kiln	منفذ خروج من الثور/القمن
20 finished malt collecting hopper	قادوس الملت تام التجهيز
21 transformer station	محطة المحوّل
22 cooling compressors	ضواغط التبريد
23 green malt (germinated barley)	ملت أخضر (شعير منبت)
24 turner (plough)	آلية قلابية (محرّات)
25 central control room	خجرة التحكم المركزي مع

24 fishing boat	قارب صيد
25 ring net cast in a circle	رمية شبكة مستديرة في دائرة
26 cable for closing the ring net	كبل إقفال الشبكة المستديرة
27 closing gear	عدة إقفال
28-29 long-line fishing (long-lining)	الصيد باستخدام حبل طويل
28 long line	حبل طويل
29 suspended fishing tackle	أداة صيد معلقة
91 Mills	المطواحين
1-34 windmill	الطاحونة الهوائية
1 windmill vane (windmill sail, windmill arm)	ريشة الطاحونة الهوائية (شراع الطاحونة، ذراع الطاحونة)
2 stock (midding, back, radius)	دعامة (متوسطة، خلفية، نصف قطرية)
3 frame	إطار
4 shutter	غطاء متحرك
5 wind shaft (sail axle)	عمود الريح (محور الشراع)
6 sail top	قمة الشراع
7 brake wheel	دولاب المكبح
8 brake	مكبح، فرملة
9 wooden cog	لسان خشبي
10 pivot bearing (step bearing)	مضلل محور الارتكاز
11 wallower	قلاية
12 mill spindle	محور دوران الطاحونة
13 hopper	قادوس
14 shoe (trough, spout)	حذاء (مجرى، مزراب)
15 miller	عامل الطاحونة
16 millstone	حجر الرعي
17 furrow (flute)	شق، تلم
18 master furrow	تلم رئيسي
19 eye	عروة
20 hurst (millstone casing)	بيت حجر الرعي
21 set of stones (millstones)	طاقم من حجرين (حجرا الرعي)
22 runner (upper millstone)	حجر الرعي (الحجر الدوار العلوي)
23 bed stone (lower stone, bedder)	حجر الأساس (حجر الرعي السفلي)
24 wooden shovel	جاروف خشبي
25 bevel gear (bevel gearing)	ترس مخروطي
26 bolter (sifter)	مُثَلّ آلي
27 wooden tub (wooden tun)	حوض خشبي
28 flour	طحين، دقيق
29 smock windmill (Dutch windmill)	طاحونة هوائية سميّة (طاحونة هولندية)
30 rotating (revolving) windmill cap	رأس الطاحونة الدوّارة
31 post windmill (German windmill)	طاحونة عمودية (طاحونة ألمانية)
32 tailpole (pole)	عمود الذيل
33 base	قاعدة
34 post	دعامة عمودية

79-87 hooks	أنواع خُطَاف الصنّارة
79 fish hook	خُطَاف عادي
80 point of the hook with barb	طرف الخُطَاف المدبب وبه شوكة
81 bend of the hook	منحنى الخُطَاف
82 spade (eye)	عروة
83 open double hook	خُطَاف مزدوج مفتوح
84 limerick	العميرك
85 closed treble hook (triangle)	خُطَاف ثلاثي مَقوّل
86 carp hook	خُطَاف سمك الشبوط
87 eel hook	خُطَاف الأنقليس
88-92 leads (lead weights)	أثقال الرصاص
88 oval lead (oval sinker)	ثقل رصاصي بيضوي
89 lead shot	كرتية رصاص
90 pear-shaped lead	ثقل رصاصي أجاصي
91 plummet	ثقل الفان
92 sea lead	ثقل بحري
93 fish ladder (fish pass, fish way)	مَرَقَى الأسماك
94 stake net	شبكة كيسية
90 Sea Fishing	الصيد في البحار
1-23 deep-sea fishing	الصيد في أعالي البحار
1-10 drift net fishing	الصيد بطريقة شبكة صيد السمك المنجرف مع التيار
1 herring lugger (fishing lugger, lugger)	لُغْر صيد الرنكة (سفينة ذات أشرعة مميّنة الشكل)
2-10 herring drift net	شبكة صيد الرنكة المنجرفة مع التيار
2 buoy	طاافية، شمنذورة
3 buoy rope	حبل الطاافية
4 float line	حبل طاف
5 seizing	رباط
6 wooden float	عوامة خشبية
7 headline	الحبل العلوي
8 net	شبكة
9 footrope	الحبل السفلي
10 sinkers (weights)	غزاطس
11-23 trawl fishing (trawling)	الصيد بواسطة الترولة (شبكة تسحب عبر قاع البحر)
11 factory ship, a trawler	سفينة الترولة
12 warp (trawl warp)	حبل الترولة السميك
13 otter boards	ألواح خشبية
14 net sonar cable	كبل سونار الشبكة
15 wire warp	حبل سلكي سميك
16 wing	جناح، جانب
17 net sonar device	جهاز سونار الشبكة
18 footrope	الحبل السفلي
19 spherical floats	عوامات كروية
20 belly	جزء الترولة المنتفخ
21 1,800 kg iron weight	ثقل حديدي زنة 1800 كجم
22 cod end (cod)	نهاية بقليّة
23 cod line for closing the cod end	حبل إقفال النهاية البقلية
24-29 inshore fishing	الصيد قرب الشاطئ

with flow diagram	رسم تخطيطي لسير العمليات
26 screw conveyor	ناقلة لولبية
27 washing floor	طابق الغسيل
28 steeping floor	طابق النقع
29 drying kiln	ثُور التجفيف
30 curing kiln	ثُور المعالجة بالتخمير
31 barley silo	صومعة الشعير
32 weighing apparatus	جهاز الوزن
33 barley elevator	رافعة الشعير
34 three-way chute (three-way tippler)	مَجْرَى مائل ذو ثلاثة فروع
35 malt elevator	رافعة المَلْت
36 cleaning machine	مآكينة التنظيف
37 malt silo	صومعة المَلْت
38 corn removal by suction	إزالة الحبوب عن طريق الشفط
39 sacker	جهاز تعبئة الأكياس
40 dust extractor	وَحْدَة إستخراج الأتربة
41 barley reception	استقبال الشعير
42-53 mashing process in the mashhouse	عملية تحويل المَلْت إلى جريش بداخل وحدة الجريش
42 premasher (converter) for mixing grist and water	جهاز لخلط الحبوب المَعْدَة للطحن مع الماء
43 mash tub (mash tun) for mashing the malt	حوض مَرَس المَلْت
44 mash copper (mash tun, Am. mash kettle) for boiling the mash	مَرَجَل لغلي المَلْت المجروش
45 dome of the tun	قبة المَرَجَل
46 propeller (paddle)	رِفَاص
47 sliding door	باب انزلاقي
48 water (liquor) supply pipe	ماسورة إمداد الماء (محلول النقع)
49 brewer (master brewer, masher)	صانع البيرة أو الجعة
50 lauter tun for settling the draff (grains) and filtering off the wort	حوض ترسيب الحبوب وترشيح نقيع الشعير
51 lauter battery for testing the wort for quality	بطارية اختبار جودة نقيع الشعير
52 hop boiler (wort boiler) for boiling the wort	مَرَجَل حشيشة الدينار لغلي نقيع الشعير
53 ladle-type thermometer (scoop thermometer)	ترموتر على شكل مِرْفَعة
93 Brewing II	تَصْنِيع الجَعَة (2)
1-31 brewery (brew-house)	مَصْنَع الجَعَة
1-5 wort cooling and break removal (trub removal)	تبريد نقيع الشعير وإزالة الهشيم
1 control desk (control panel)	لَوْحَة التحكم
2 whirlpool separator for removing the hot break (hot trub)	فَرَّان دَوَامِي لإزالة الهشيم الساخن
3 measuring vessel for	وعاء قياس التراب النقاقي

the kieselguhr	مُرْبَع التراب النقاقي
4 kieselguhr filter	مَبْرَد نقيع الشعير
5 wort cooler	مَعْمَل إستبات نقي الخميرة
6 pure culture plant for yeast (yeast propagation plant)	قَبْو التخثير
7 fermenting cellar	وعاء التخثير
8 fermentation vessel (fermenter)	ترموتر التخثير (ترموتر الجريش)
9 fermentation thermometer (mash thermometer)	جَرِيش المَلْت المتنوع
10 mash	نظام التبريد
11 refrigeration system	قَبْو الجَعَة الخفيفة
12 lager cellar	فتحة الدخول إلى صهرج التخزين
13 manhole to the storage tank	صُنْبُور الصهرج
14 broaching tap	مُرْبَع الجَعَة
15 beer filter	مَخْرَن البراميل
16 barrel store	برميل جَعَة، برميل ألومنيوم
17 beer barrel, an aluminum (Am. aluminum) barrel	مَعْمَل غَسَل الرُجَاجَات
18 bottle-washing plant	مآكينة غَسَل الرُجَاجَات
19 bottle-washing machine (bottle washer)	لَوْحَة التحكم
20 control panel	رُجَاجَات تم تنظيفها
21 cleaned bottles	تعبئة الرُجَاجَات/التقنيات
22 bottling	عربة بمرْفَاع شَوَكِي
23 forklift truck (fork truck, forklift)	مجموعة من صناديق الجَعَة
24 stack of beer crates	عَلِيَة جَعَة
25 beer can	رُجَاجَة/تعبئة جَعَة، أنواع الجَعَة خفيفة (مَعْتَقَة، المَرَز الخفيف، المَرَز المر)، الجَعَة الدَاكِنَة (المَرَز البُنِّي، متوسط)، جَعَة بلزِينر، جَعَة ميونخ، جَعَة الشعير، الجَعَة القوية (جَعَة الربيع، جَعَة المَرَز، جَعَة السلفادور، جَعَة الحنطة)
26 beer bottle, a Eurobottle with bottled beer; <i>kinds of beer</i> : light beer (lager, light ale, pale ale or bitter), dark beer (brown ale, mild), Pilsener beer, Munich beer, malt beer, strong beer (bock beer), porter, ale, stout, Salvator beer, wheat beer, small beer	سِدَادَة فلينية تاجية
27 crown cork (crown cork closure)	عَبْوَة غير مَرْتَجَعَة
28 disposable pack (carry-home pack)	رُجَاجَة غير مَرْتَجَعَة
29 non-returnable bottle (single-trip bottle)	كَأْس الجَعَة
30 beer glass	رَعْوَة (رَأْس) الجَعَة
31 head	المَجْرَز/المَسْلُح
94 Slaughterhouse (Abattoir)	الجَزَار، القَصَاب
1 slaughterman (Am. slaughterer, killer)	حيوان للذبح، ذبيحة
2 animal for slaughter, an	

ox	مَدَس صَدْمِي
3 captive-bolt pistol (pneumatic gun), a stunning device	مَسْمَار خَرَّاطِيش
4 bolt	ذِرَاع الإعتاق (رَنَاد)
5 cartridges	صاعق كهربي
6 release lever (trigger)	الكتروود
7 electric stunner	سلك كهربي
8 electrode	وقاء اليد
9 lead	خنزير ذبيح
10 hand guard (insulation)	عَلِيَة السكاكين
11 pig (Am. hog) for slaughter	سَكِين السَّلْح
12 knife case	مِدْيَة الطعن
13 flaying knife	سَكِين الجَزَار
14 sticking knife (sticker)	مَسْ السكاكين
15 butcher's knife (butcher knife)	سَاطور فُلُق
16 steel	سَاطور الجَزَار
17 splitter	مَشَار العظم
18 cleaver (butcher's cleaver, meat ax (Am. meat ax))	مَشَار تقطيع اللحم إلى أوصال
19 bone saw (butcher's saw)	غُرْفَة التبريد، المِرْزَاد
20 meat saw for sawing meat into cuts	عصا حديدية لتعليق الذبائح
21-24 cold store (cold room)	رَبْع الذبيحة
21 gambrel (gambrel stick)	جانب الخنزير المذبوح
22 quarter of beef	خاتم مفتش اللحوم
23 side of pork	
24 meat inspector's stamp	
95 Meat Joints	أَوْصَال اللَّحْم
<i>left</i> : meat side;	يسارا. جانب اللحم
<i>right</i> : bone side	يمينًا. جانب العظم
1-13 animal: calf; meat: veal	الحيوان عَجَل؛ اللَّحْم
1 leg with hind knuckle	لَحْم عَجَل صَغِير (بِتْلُو)
2 flank	الرُسْع واللَّحْم المحيط به
3 loin and rib	خاصرة
4 breast (breast of veal)	بَيْت الكلاوي والضلوع
5 shoulder with fore knuckle	الصدر (صدر العجل)
6 neck with scrag (scrag end)	كف بالزُند واللَّحْم المحيط به
7 best end of loin (of loin of veal)	الكراع
8 fore knuckle	الرقبة واللَّحْم المحيط بها
9 shoulder	قِطْعَة لَحْم من الخاصرة
10 hind knuckle	الرُؤْد واللَّحْم المحيط به
11 roasting round (oyster round)	الكفف
12 cutlet for frying or braising	الرُسْع واللَّحْم المحيط به
13 undercut (fillet)	شريحة سمكة للشوي
	كَسْطَلِيَة للشوي أو التسبيح بالبقير
	قِطْعَة لَحْم من داخل الخاصرة

14-37 animal: ox; meat: beef	الحيوان: ثُور؛ اللَّحْم
14 round with rump and shank	بِقْرِي
15-16 flank	الفخذ ولَحْم وعظم الساق
15 thick flank	خاصرة
16 thin flank	لَحْم سَمِيك من الخاصرة
17 sirloin	لَحْم رقيق من الخاصرة
18 prime rib (fore ribs, prime fore rib)	شريحة من أعلى الخاصرة
19 middle rib and chuck	لَحْم أعلى السلسلة
20 neck	الضلوع الوسطى وجزء من لَحْم الكفف
21 flat rib	الرقبة
22 leg of mutton piece (bladebone) with shin	الضلع الأمامي
23 brisket (brisket of beef)	الرُؤْد وعظمة اللُوح في الضان
24 fillet (fillet of beef)	لَحْم الصدر
25 hind brisket	فيليه
26 middle brisket	لَحْم الصدر الخلفي
27 breastbone	لَحْم الضلوع
28 shin	عظم الصدر
29 leg of mutton piece	عظم الرُؤْد
30 bladebone [meat side]	فخذ الضان
31 part of top rib	عظمة اللُوح [جانب اللَحْم]
32 bladebone [bone side]	جزء من الضلع العلوي
33 shank	عظمة اللُوح [جانب العظم]
34 silverside	لَحْم عظم الساق
35 rump	جزء من لَحْم الساق
36 thick flank	قِطْعَة من لَحْم الفخذ
37 top side	لَحْم الخاصرة السميك الجزء العلوي
38-54 animal: pig; meat: pork	الحيوان خنزير؛ اللَّحْم
38 leg with knuckle and trotter	لَحْم خنزير
39 ventral part of the belly	عظم الفخذ واللَّحْم المحيط به والكراع
40 back fat	اللَّحْم البطني
41 belly	شَحْم الظهر
42 bladebone with knuckle and trotter	البطن
43 head (pig's head)	عظم الرُسْع واللَّحْم المحيط به والكراع
44 fillet (fillet of pork)	رَأْس (رَأْس الخنزير)
45 leaf fat (pork flare)	فيليه لَحْم الخنزير
46 loin (pork loin)	دهن التجوف البطني
47 spare rib	خاصرة الخنزير
48 trotter	الأرب الضلعي
49 knuckle	الكراع
50 butt	عظم الرُسْع
51 fore end (ham)	الجزء اللَحْمِي السميك
52 round end for boiling	الفخذ الأمامية
53 fat end	قِطْعَة من اللَّحْم السميك للسلق الشَّحْم
54 gammon steak	لَحْم إعداد ستيك الخنزير المقعد
96 Butcher's Shop (الملحمة)	مَحَل الجَزَارَة/القَصَاب (الملحمة)
1-30 butcher's shop	محل الجَزَارَة، الملحمة
1-4 meat	اللحوم
1 ham on the bone	فخذ خنزير بالعظم

2 flitch of bacon	قطعة مُملّحة ومُقَدَّدة من خاصرة الخنزير
3 smoked meat	لَحْمٌ مَدْحَنٌ
4 piece of loin (piece of sirloin)	قطعة من لَحْمِ الخاصرة
5 lard	سَحْمُ الخنزير
6-11 sausages	المقانيق
6 price label	بطاقة السعر
7 mortadella	مُرْتَدِيلَا
8 scalded sausage; <i>kinds</i> : Vienna sausage	مقانيق مسلوقة، أنواعها مقانيق فيينا ، مقانيق فرانكفورت
9 collared pork (<i>Am.</i> headcheese)	لَحْمٌ خنزير ملفوف ومنقوع في الخل
10 ring of [Lyoner] sausage	حلقة من مقانيق [الليونر]
11 pork sausages; <i>also</i> : beef sausages	مقانيق لَحْمِ الخنزير، أيضاً مقانيق لَحْمِ بقري
12 cold shelves	رفوف اللحوم المُبرِّدة
13 meat salad (diced meat salad)	سلطة لحوم
14 cold meats (<i>Am.</i> cold cuts)	لَحْمٌ بارد
15 pâté	قطيرة لَحْمٍ (باتيه)
16 mince (mincemeat, minced meat)	لَحْمٌ مفروم
17 knuckle of pork	عَظْمٌ رُسْعُ الخنزير واللحم المحيط به
18 basket for special offers	سلّة العروض الخاصة
19 price list for special offers	قائمة أسعار العروض الخاصة
20 special offer	عَرْضٌ خاص
21 freezer	فريزر
22 pre-packed joints	قطع لَحْمٍ مُغلّفة
23 deep-frozen ready-to-eat meal	وَجِبَةٌ مُجمِّدة جاهزة للأكل
24 chicken	دَجَاجَةٌ
25 canned food	طعام مُعلَّب
26 can	عَلْبَةٌ
27 canned vegetables	خضروات مُعلَّبة
28 canned fish	أسماك مُعلَّبة
29 salad cream	كريمة سلطة
30 soft drinks	مشروبات خفيفة
31-59 manufacturing of sausages	تصنيع المقانيق
31-37 butcher's knives	سكاكين الجزار
31 slicer	المشْرحة سكين تقطيع الشرائح
32 knife blade	حُصَلُ السكين
33 saw teeth	أَسنان مُشْأارية
34 knife handle	مقبض السكين
35 carver (carving knife)	سكين كبيرة لتقطيع اللحم إلى شرائح
36 boning knife	سكين إزالة اللحم عن العظم (سكين التَّنْقِيَة)
37 butcher's knife (butcher knife)	سكين الحَزَار

38 butcher (master butcher)	الجَزَار، القِصَاب
39 butcher's apron	مربطة الجَزَار
40 meat-mixing trough	وعاء خلط اللحوم
41 sausage meat	لَحْمُ المقانيق
42 scraper	مَكْحَةٌ
43 skimmer	مَكْحُطَةٌ
44 sausage fork	شُوكة المقانيق
45 scalding colander	مصفاة الملح
46 waste bin (<i>Am.</i> trash bin)	صفيحة الفضلات
47 cooker, for cooking with steam or hot air	جهاز الطبخ، الطبخ (للطهي بالبخار أو الهواء الساخن)
48 smoke house	بيت الدخان
49 sausage filler (sausage stuffer)	جهاز حشو المقانيق
50 feed pipe (supply pipe)	أنبوب الحشو
51 containers for vegetables	أوعية للخضروات
52 mincing machine for sausage meat	ماكينة فرم لحوم المقانيق
53 mincing machine (meat mincer, mincer, <i>Am.</i> meat grinder)	ماكينة فرم، مفرمة اللحوم
54 plates (steel plates)	صفايح معدنية
55 meathook (butcher's hook)	حُطَّافٌ لتعليق اللحوم
56 bone saw	مَشْأار العظم
57 chopping board	سطح تقطيع اللحوم
58 butcher, cutting meat	جَزَار يقطع اللحوم
59 piece of meat	قطعة/وصلة لَحْمٍ

97 Bakery

1-54 baker's shop	محل الخباز
1 shop assistant (<i>Am.</i> salesgirl, saleslady)	البايع/البائعة
2 bread (loaf of bread, loaf)	خبز (رغيف خبز)
3 crumb	أَباب الرغيف
4 crust (bread crust)	سطح الرغيف الخارجي المحمص
5 crust (<i>Am.</i> heel)	كعب الرغيف
6-12 kinds of bread (breads)	أنواع الخبز
6 round loaf, a wheat and rye bread	رغيف مستدير، رغيف من دقيق القمح أو الشيلم
7 small round loaf	رغيف صغير مستدير
8 long loaf (bloomer), a wheat and rye bread	رغيف طويل، رغيف من دقيق القمح أو الشيلم
9 white loaf	رغيف أبيض
10 pan loaf, a wholemeal rye bread	رغيف من دقيق الشيلم الأسمر
11 yeast bread (<i>Am.</i> stollen)	خبز يدخل في صنعه الخميرة
12 French loaf (baguette, French stick)	خبز فرنسي
13-16 rolls	أرغفة الخبز الإفريقي
13 brown roll	رغيف إفريقي أسمر
14 white roll	رغيف إفريقي أبيض

15 finger roll	رغيف إفريقي صغير
16 rye-bread roll	رغيف من دقيق الشيلم الكعك (الحلوى)
17-47 cakes (confectionery)	رول الكريمة
17 cream roll	نوع من الفطائر المنتخخة
18 vol-au-vent, a puff pastry (<i>Am.</i> puff paste)	سويس رول
19 Swiss roll (<i>Am.</i> jelly roll)	تورته صغيرة
20 tartlet	شريحة من كعكة الكريمة
21 cream slice	الفطائر (الكعك) والجاتوه
22-24 flans (<i>Am.</i> pies) and gateaux (torten)	كعكة الفاكهة، أنواعها الفرافولة، الكرز، الكشميش، الخوخ، الرواند
22 fruit flan (<i>kinds</i> : strawberry flan, cherry flan, gooseberry flan, peach flan, rhubarb flan)	كعكة الجبن
23 cheesecake	كعكة الكريمة
24 cream cake (<i>Am.</i> cream pie) (<i>kinds</i> : buttercream cake, Black Forest gateau)	(أنواعها كعكة بالزبد، جاتوه بلاك فورست)
25 cake plate	قاعدة الكعكة
26 meringue	كعكة المرنغ
27 cream puff	فطائر الكريمة المنتخخة
28 whipped cream	كريمة مخفوقة
29 doughnut (<i>Am.</i> biscuit)	دونات (كعكة مخلّعة مقلية بالدهن)
30 Danish pastry	كعكة الدانيش
31 saltstick (Saltzstange) (<i>also</i> : caraway roll, caraway stick)	أصابع مالحة (بالزيون) (أيضاً أصابع الكُمون)
32 croissant (crescent roll, <i>Am.</i> crescent)	كرواسون
33 ring cake (gugelhupf)	كعكة جزئية الشكل
34 slab cake with chocolate icing	كعكة مكعبة الشكل مغطاة بالشوكولاته
35 streusel cakes	كعك الإسترويسيل
36 marshmallow	كعك المارش مالو
37 coconut macaroon	مكرونة جوز الهند
38 pastry whirl	فطائر حلوة
39 iced bun	فطائر بالزبيب مكسوة بطبقة من السكر والزبد
40 sweet bread	خبز حلو
41 plaited bun (plait)	صفيحة بالزبيب مكسوة بطبقة من السكر والزبد
42 Frankfurter garland cake	كعكة إكليل فرانكفورت
43 slices (<i>kinds</i> : streusel slices, sugared slices, plum slices)	شرائح حلوى (الأنواع الأسترويسيل، شرائح مغطاة بالسكر، شرائح مغطاة بالأجاص)
44 pretzel	عقدية بسكوتيت مملح صلب
45 wafer (<i>Am.</i> waffle)	الو ففر (بسكوتيت رقائق هشة)
46 tree cake (baumkuchen)	كعكة الشجرة
47 flan case	علبة الكعكة

48-50 wrapped bread	خبز مغلّف
48 wholemeal bread (<i>also</i> : wheatgerm bread)	خبز أسمر
49 pumpernickel (wholemeal rye bread)	خبز الشيلم الأسمر
50 crispbread	خبز رقائق هش
51 gingerbread (<i>Am.</i> lebkuchen)	كعكة الزنجبيل
52 flour (<i>kinds</i> : wheat flour, rye flour)	دقيق/حنطة، أنواعه قمح، شيلم
53 yeast (baker's yeast)	خميرة (خميرة خبز)
54 rusks (French toast)	بُقسماط، خبز مُحْمَص (توست فرنسي)
55-74 bakery (bakehouse)	المخبز
55 kneading machine (dough mixer)	خلاط العجين
56-57 bread unit	وحدة صناعة الخبز
56 divider	وحدة تقسيم
57 moulder (<i>Am.</i> molder)	وحدة التشكيل
58 premixer	خلاط أولي
59 dough mixer	خلاط العجين
60 workbench	سطح العمل
61 roll unit	وحدة إعداد الأرغفة
62 workbench	سطح العمل، طاولة العمل
63 divider and rounder (rounding machine)	ماكينة التقسيم والقرصيص
64 crescent-forming machine	ماكينة تشكيل الكرواسون
65 freezers	ثلاجات تجميد
66 oven [for baking with fat]	فرن [للخبز بالدهن]
67-70 confectionery unit	وحدة صناعة الحلوى
67 cooling table	طاولة التبريد
68 sink	حوض غسل
69 boiler	برجل، غلاية
70 whipping unit [with beater]	وحدة خفق البيض أو الكريمة (مزودة بمضرب)
71 reel oven (oven)	فرن
72 fermentation room	خبرة التخضير
73 fermentation trolley	تrolley التخضير
74 flour silo	صومعة الطحين/الدقيق
98 Grocer's Shop (<i>Am.</i> Grocery Store)	دكان البقالة
1-87 grocer's shop (grocer's, delicatessen shop, <i>Am.</i> grocery store, delicatessen store), a retail shop (<i>Am.</i> retail store)	دكان البقالة (محل البيع القمّاعي)
1 window display	واجهة العرض
2 poster (advertisement)	بوستر (إعلان)
3 cold shelves	أرفف المنتجات المُبرِّدة
4 sausages	مقانيق، مقانق
5 cheese	جبن
6 roasting chicken (broiler)	دجاجة معدة للشواء
7 poulard, ■ fattened hen	دجاجة مُسمّنة

8-11 baking ingredients	مكونات الخبزي
8 raisins; <i>sim.</i> : sultanas	زبيب
9 currants	كشمش
10 candied lemon peel	قشر ليمون مسكّر
11 candied orange peel	قشر برتقال مسكّر
12 computing scale, ■ rapid scale	ميزان حاسب
13 shop assistant (<i>Am.</i> salesclerk)	بائع/بائعة
14 goods shelves (shelves)	أرفف البضائع
15-20 canned food	أطعمة معلبة
15 canned milk	لبن مملّب
16 canned fruit (cans of fruit)	فاكهة معلبة
17 canned vegetables	خضروات معلبة
18 fruit juice	عصير فواكه
19 sardines in oil, ■ can of fish	سردين بالزيت. علبّة
20 canned meat (cans of meat)	لحوم معلبة
21 margarine	مرغرين
22 butter	زبد
23 coconut oil, a vegetable oil	زيت جوز الهند، زيت نباتي
24 oil; <i>kinds</i> : salad oil, olive oil, sunflower oil, wheatgerm oil, groundnut oil	زيت، أنواعه زيت السلطة، زيت زيتون، زيت عباد/دوار الشمس، زيت أحيّة القمح، زيت الجوز، خلّ
25 vinegar	مكعبات مرقّ
26 stock cube	مكعبات مرقّ
27 bouillon cube	زيت الخردال
28 mustard	خيار صغير مملّب
29 pickled gherkin	توابل الصّساء
30 soup seasoning	بائع، بائعة
31 shop assistant (<i>Am.</i> salesgirl, saleslady)	البائسة (المعجنات)
32-34 pastas	اسباغيتي
32 spaghetti	مكرونه
33 macaroni	عصائبيّة (نودلز)
34 noodles	منتجات الحبوب
35-39 cereal products	خبّ الشعير
35 pearl barley	السيمولينا
36 semolina	شوفان
37 rolled oats (porridge oats, oats)	أرز
38 rice	ساجو (نوع من نبات الخليل)
39 sago	بطيخ
40 salt	البقال (تاجر، بائع تجرّبة)
41 grocer (<i>Am.</i> groceryman), a shopkeeper (tradesman, retailer, <i>Am.</i> storekeeper)	كبر مملّب
42 capers	زبون
43 customer	ايصال استلام نقدية
44 receipt (sales check)	حقيبة التسوّق
45 shopping bag	مواد اللّف/التغليف
46-49 wrapping material	ورق تغليف
46 wrapping paper	

47 adhesive tape	شريط لاصق
48 paper bag	كيس ورقي
49 cone-shaped paper bag	كيس ورقي مخروطي الشكل (قرطاس)
50 blancmange powder	مسحوق مهلبية
51 whole-fruit jam (preserve)	مربّى فواكه محفوظة
52 jam	مربّى
53-55 sugar	السكر
53 cube sugar	سكر مكعبات
54 icing sugar (<i>Am.</i> confectioner's sugar)	سكر ناعم
55 refined sugar in crystals	سكر مكرّر في شكل بلورات
56-59 spirits	المشروبات الكحولية
56 whiskey (whiskey)	ويسكي
57 rum	روم
58 liqueur	شراب مسكّر معطر
59 brandy (cognac)	براندي (كونياك)
60-64 wine in bottles (bottled wine)	نبيذ معبأ في زجاجات
60 white wine	نبيذ أبيض
61 Chianti	كبيانتّي (نوع من الخمر الإيطالي)
62 vermouth	فيرموت (نوع من الخمر الأبيض)
63 sparkling wine	نبيذ الأوفر
64 red wine	نبيذ أحمر
65-68 tea, coffee, etc.	الشاي، القهوة/البن، الخ.
65 coffee (pure coffee)	قهوة (بن خالص)
66 cocoa	كاكاو
67 coffee	قهوة، بن
68 tea bag	كيس شاي
69 electric coffee grinder	مطحّنة بن كهربائية
70 coffee roaster	مخصّمة البن
71 roasting drum	برميل التحميص
72 sample scoop	مفرقة أخذ العينات
73 price list	قائمة الأسعار
74 freezer	ثلاجة تجميد (براد)
75-86 confectionery (<i>Am.</i> candies)	الحلويات
75 sweet (<i>Am.</i> candy)	حلوى
76 drops	حيات البونبون
77 toffees	طوفي
78 bar of chocolate	لوح شوكولاته
79 chocolate box	صندوق شوكولاته
80 chocolate, a sweet	شوكولاته، نوع من الحلوى
81 nougat	نوغه
82 marzipan	مرزيبانية
83 chocolate liqueur	شوكولاته بها شراب مسكّر
84 Turkish delight	حلّقوم (ملين)
85 croquant	حلوى الكروكوات
86 truffle	ترافل
87 soda water	ماء صودا

99 Supermarket

1-96 supermarket, a self-service food store	سوپر ماركت (متجرّ الخدمة الذاتية)
1 shopping trolley	سوپر ماركت (متجرّ الخدمة الذاتية)
2 customer	تروالي/عربة التسوق
3 shopping bag	زبون
4 entrance to the sales area	حقيبة التسوّق
5 barrier	مدخل منطقة المبيعات
6 sign (notice) banning dogs	حاجز
7 dogs tied by their leads	لافتة تحظر دخول الكلاب
8 basket	كلاب ملسلة
9 bread and cake counter (bread counter, cake counter)	سلّة
10 display counter for bread and cakes	قسم الخبز والكعك
11 kinds of bread (breads)	كاونتر عرض الخبز
12 rolls	والكعك
13 croissants (crescent rolls, <i>Am.</i> crescents)	أنواع من الخبز
14 round loaf	أرغفة خبز إفرنجي
15 gateau	كرواسون
16 pretzel [made with yeast dough]	راغيف مستدير
17 shop assistant (<i>Am.</i> salesgirl, saleslady)	جاواه
18 customer	عقدية [مصنوعة من عجينة مخمرة]
19 sign listing goods	بائع، بائعة
20 fruit fan	زبون
21 slab cake	لافتة بأسماء المعروضات
22 ring cake	كعك الفاكهة
23 cosmetics gondola, a gondola (sales shelves)	كعكة مكعبة الشكل
24 canopy	كعكة جرسية الشكل
25 hosiery shelf	أرفف مستحضرات التجميل
26 stockings (nylons)	زبون
27-35 toiletries (cosmetics)	لافتة بأسماء المعروضات
27 jar of cream (cream; <i>kinds</i> : moisturising cream, day cream, night-care cream, hand cream)	كعك الفاكهة
28 packet of cotton wool	كعكة مكعبة الشكل
29 talcum powder	كعكة جرسية الشكل
30 packet of cotton wool balls	أرفف مستحضرات التجميل
31 toothpaste	مظلة، ثدّة
32 nail varnish (nail polish)	رغف الجوارب
33 shaving cream	جوارب نسائية
34 bath salts	مستحضرات التجميل
35 sanitary articles	علبة كريم (كريم؛ الأنواع: كريم ترطيب البشرة، كريم نهار، كريم ليل، كريم اللينين)
36-37 pet foods	لغافة قطن ماص
36 complete dog food	بودرة التلك
37 packet of dog biscuits	عربة كريات من القطن الماص

38 bag of cat litter	عربة مهاد من الفلّس القلط
39 cheese counter	قسم الألبان
40 whole cheese	جبّين كامل الدسم
41 Swiss cheese (Emmental cheese) with holes	جبّين سويسري ذو ثقوب
42 Edam cheese, a round cheese	جبّين ايدام، قرص جبّين مستدير
43 gondola for dairy products	قسم منتجات الألبان
44 long-life milk; also: pasteurized milk, homogenized milk	لبن يبقى طازجا فترة طويلة؛ أيضا لبن مبستر ولبن مملّب
45 plastic milk bag	كيس لبن بلاستيكي
46 cream	قشطة
47 butter	زبد
48 margarine	مرغرين
49 box of cheeses	صندوق جبّان
50 box of eggs	صندوق بيض
51 fresh meat counter (meat counter)	قسم اللحوم الطازجة
52 ham on the bone	فخذ خنزير بالعظم
53 meat (meat products)	لحوم (منتجات اللحوم)
54 sausages	نقانق، مقانق
55 ring of pork sausage	حلقة من نقانق الخنزير
56 ring of blood sausage	حلقة من المقانق المدّامة
57 freezer	ثلاجة تجميد (براد)
58-61 frozen food	أطعمة مجمّدة
58 poultry	دجاجة مسنّمة
59 turkey leg (drumstick)	ورّك ديك رومي
60 boiling fowl	لحم دجاج للسلق
61 frozen vegetables	خضروات مجمّدة
62 gondola for baking ingredients and cereal products	قسم مكونات الخبز ومنتجات الحبوب
63 wheat flour	دقيق القمح
64 sugar loaf	رغيف سكر
65 packet of noodles	عربة عصائبيّة (نودلز)
66 salad oil	زيت السلطة
67 packet of spice	عربة توابل
68-73 tea, coffee, etc.	الشاي والقهوة، الخ.
68 coffee	قهوة (بن)
69 packet of tea	عربة شاي
70 instant coffee	قهوة سريعة التحضير
71 drinks gondola	قسم المشروبات
72 soft drinks	مشروبات خفيفة
73 can of beer	علبة جبّ
74 bottle of fruit juice	زجاجه عصير فواكه
75 can of fruit juice	علبة عصير فواكه
76 bottle of wine	زجاجه نبيذ
77 bottle of Chianti	زجاجه كبيانتّي
78 bottle of champagne	زجاجه شبانيا
79 emergency exit	مخرج الطوارئ
80 fruit and vegetable counter	قسم الفاكهة والخضروات
81 vegetable basket	سلّة الخضروات
82 tomatoes	طماطم
83 cucumbers	خيار
84 cauliflower	قنبط

85 pineapple	أناناس
86 apples	تفاح
87 pears	كمثرى
88 scales for weighing fruit	ميزان الفواكه
89 grapes (bunches of grapes)	عنب (عناقيد عنب)
90 bananas	موز
91 can	علبة معدنية
92 checkout	دفع الحصاب والمغادرة
93 cash register	مَسْجِلَةُ النَقْد
94 cashier	أمين الصندوق
95 chain	سلسلة
96 assistant departmental manager	مُساعد مدير المتجر
100 Shoemaker (Bootmaker)	الإسكافي
1-68 shoemaker's workshop (bootmaker's workshop)	ورشة صانع الأحذية، ورشة الإسكافي
1 finished (repaired) shoes	أحذية تم إصلاحها
2 auto-soling machine	مآكينة تركيب النعال ألياً
3 finishing machine	مآكينة التنظيب
4 heel trimmer	آلة تشذيب الكعب
5 sole trimmer	آلة تشذيب النعل
6 scouring wheel	عجلة إزالة الشحم/تنظيف
7 naum keag	آلية تلميع وصقل سطح النعل والكعب قبل التنظيب
8 drive unit (drive wheel)	عجلة الإدارة
9 iron	ميسم
10 buffing wheel	عجلة الصقل
11 polishing brush	فرشاة التلميع
12 horsehair brush	فرشاة من شعر الخيل
13 extractor brush	شبكة آلة الخلع
14 automatic sole press	مكّس النعال الآلي
15 press attachment	ملحق المكيس
16 pad	لبادة، حشية
17 press bar	قضيب المكيس
18 stretching machine	مآكينة المط/الإطالة
19 width adjustment	مقبض ضبط العرض
20 length adjustment	مقبض ضبط الطول
21 stitching machine	مآكينة الخياطة
22 power regulator (power control)	مُنظّم الطاقة الكهربائية
23 foot	الطرف السفلي
24 handwheel	عجلة يدوية
25 arm	ذراع
26 sole stitcher (sole-stitching machine)	مآكينة خياطة النعال
27 foot bar lever	ذراع قضيب الطرف السفلي
28 feed adjustment (feed setting)	تعديل الإلقام
29 bobbin (cotton bobbin)	بكرة، بوبينة
30 thread guide (yarn guide)	دليل الخنط
31 sole leather	جلد النعل
32 [wooden] last	قالب أحذية [خشبي]

33 workbench	طاولة الشغل
34 last	قالب أحذية
35 dye spray	رشاش الصبغة
36 shelves for materials	أرفف المواد
37 shoemaker's hammer	مطرقة الإسكافي
38 shoemaker's pliers (welt pinners)	مكاشاة الإسكافي
39 sole-leather shears	مقص جلد النعال
40 small pinners (nippers)	قراضة صغيرة
41 large pinners (nippers)	قراضة كبيرة
42 upper-leather shears	مقص الجلد العلوي
43 scissors	مقص (عمادي)
44 revolving punch (rotary punch)	خزامة دوارة، مخرّز دوار
45 punch	خزامة، مخرّز
46 punch with handle	خزامة ذات مقبض
47 nail puller	مكاشاة المسامير
48 welt cutter	سكين النحاش
49 shoemaker's rasp	ميرد أحذية
50 cobbler's knife (shoemaker's knife)	سكين أحذية
51 skiving knife (skife knife, paring knife)	سكين تشريح الجلد إلى رقائق (سكين تقشير)
52 toecap remover	أداة إزالة غطاء أصابع القدم بالحاء
53 eyelet, hook, and press-stud setter	أداة عمل العراوي وتركيب المشابك وكيس المسامير
54 stand (with iron lasts)	حامل ذو قوالب حديدية
55 width-setting tree	قالب ضبط عرض الحذاء
56 nail grip	أداة إسماك وتثبيت المسامير
57 boot	حذاء ذو رقبة
58 toecap	قُرطوم الحذاء، بُطليطة
59 counter	قطعة جلد قاسية داخل موخر الحذاء المحيط بالعقب
60 vamp	وجه الحذاء
61 quarter	جانب من أعلى الحذاء
62 hook	مشبك
63 eyelet	عروة
64 lace (shoelace, boot-lace)	رباط الحذاء
65 tongue	لسان
66 sole	نعل
67 heel	كعب
68 shank (waist)	بطن النعل
101 Shoes (Footwear)	الأحذية
1 winter boot	حذاء شتوي (ذو رقبة)
2 PVC sole (plastic sole)	نعل من مادة بي في سي (نعل من البلاستيك)
3 high-pile lining	بطانة طويلة التيلة
4 nylon	نيلون
5 men's boot	بوت رجالي (حذاء ذو رقبة)
6 inside zip (Am. zipper)	سوستة داخلية
7 men's high leg boot	حذاء رجالي طويل الساق
8 platform sole (platform)	نعل مرتفع

9 Western boot (cowboy boot)	بوت غربي (حذاء رعاة البقر)
10 pony-skin boot	حذاء من جلد الخيل
11 cemented sole	نعل ميثت بالحاء بمادة لاصقة
12 ladies' boot	بوت نسائي
13 men's high leg boot	بوت رجالي طويل الساق
14 seamless PVC water-proof wellington boot	بوت ولنتون مقاوم للماء مصنوع من مادة بي في سي
15 natural-colour (Am. natural-color) sole	نعل طبيعي اللون
16 toecap	قُرطوم الحذاء
17 tricot lining (knitwear lining)	بطانة من التريكو
18 hiking boot	حذاء (بوت) التتره
19 grip sole	نعل كربي
20 padded collar	ياقة مبطنة
21 tie fastening (lace fastening)	رباط الحذاء
22 open-toe mule	شيشب بدون كعب مفتوح من الأمام
23 terry upper	قُرعة شيشب مصنوعة من شبيج وبيري
24 polo outsole	نعل خارجي من الوبر
25 mule	شيشب بدون كعب، متتوفاي
26 corduroy upper	قُرعة مصنوعة من القטיפه المضلعة
27 evening sandal (sandal court shoe)	صندل مسائي، حذاء خفيف
28 high heel (stiletto heel)	كعب عال
29 court shoe (Am. pump)	حذاء خفيف بدون رباط
30 moccasin	حذاء الموكاسين
31 shoe, a tie shoe (laced shoe, Oxford shoe, Am. Oxford)	حذاء برباط
32 tongue	لسان
33 high-heeled shoe (shoe with raised heel)	حذاء ذو كعب مرتفع
34 casual	حذاء خفيف (كاجوال)
35 trainer (training shoe)	حذاء رياضي للتدريب
36 tennis shoe	حذاء رياضي خفيف للمشي
37 counter (stiffening)	قطعة جلد قاسية لتقوية الحذاء عند العقب
38 natural-colour (Am. natural-color) rubber sole	نعل مطاطي طبيعي اللون
39 heavy-duty boot (Am. stogy, stogie)	بوت شديد التحمل
40 toecap	قُرطوم الحذاء
41 slipper	خف، شيشب
42 woollen (Am. woolen) slip sock	حذاء خفيف من الصوف
43 knit stitch (knit)	غرزة حبك بالصنارة
44 clog	حذاء خشبي
45 wooden sole	نعل خشبي
46 soft-leather upper	قُرعة من الجلد الطري
47 sabot	حذاء "سابوه"
48 toe post sandal	صندل ذو فاصل للإصبع الكبير

49 ladies' sandal	صندل نسائي
50 surgical footbed (sock)	حشية لإراحة القدم، فرشاة
51 sandal	صندل
52 shoe buckle (buckle)	إبزيم الحذاء
53 sling-back court shoe (Am. sling pump)	حذاء خفيف مققول من الأمام وبشريط من الخلف
54 fabric court shoe	حذاء خفيف من القماش
55 wedge heel	كعب إسفيني
56 baby's first walking boot	حذاء أطفال بريقة
102 Needlework	أشغال الإبرة
1 backstitch seam	خياطة بفرزة خلفية
2 chain stitch	غرزة السلسلة
3 ornamental stitch	غرزة زخرفية
4 stem stitch	غرزة ساقية
5 cross stitch	غرزة تصالبيه (رجل غراب)
6 buttonhole stitch (button stitch)	غرزة عراوي
7 fishbone stitch	غرزة عظم السمكة
8 overcast stitch	غرزة راكية (غرزة اوفر لوك)
9 herringbone stitch (Russian stitch, Russian cross stitch)	غرزة عظم سمكة الرنكة (غرزة الصليب الروسي)
10 satin stitch (flat stitch)	غرزة ستانية
11 eyelet embroidery (broderie anglaise)	ركامة
12 stiletto	نقابية التطريز
13 French knot (French dot, knotted stitch, twisted knot stitch)	غرزة فرنسية (غرزة عقدية)
14 hem stitch work	تطريز الكفة
15 tulle work (tulle lace)	زخرفة التول
16 tulle background (net background)	خلفية التول
17 darning stitch	غرزة رفي
18 pillow lace (bobbin lace, bone lace); kinds: Valenciennes, Brussels lace	دانتيل هوبنوتون
19 tatting	تخريم ذو عقد
20 tatting shuttle (shuttle)	مكوك حياكة تخريم ذو عقد
21 knotted work (macramé)	مكزمية
22 filet (netting)	غرزة الشبكة
23 netting loop	انشوطه غرزة الشبكة
24 netting thread	خيط الشبكة
25 mesh pin (mesh gauge)	قضيب الغزل
26 netting needle	إبرة غزل الشبكة
27 open work	تطريز مغرغ (أجور)
28 gimping (hairpin work)	التطريز بدبوس الشعر
29 gimping needle (hair-pin)	إبرة التطريز (دبوس الشعر)
30 needlepoint lace (point lace, needlepoint); kinds: reticella lace, Alengon lace; sim. with metal thread: fili-	دانتيل، تطريز إبري؛ مثلها تنقيب/تخريم تزييني

gree work	كَنَار تَطْبِرِيز
31 braid embroidery (braid work)	كَنَار تَطْبِرِيز
103 Dressmaker	الخِيَّاطُ
1-27 dressmaker's work-room	مَشْغَل الخِيَّاطِ
1 dressmaker	خِيَّاط
2 tape measure (measuring tape), a metre (<i>Am. meter</i>) tape measure	مَازْوَرَة (شَرِيْط قِيَاس)
3 cutting shears	مَقْصَر القِمَاش
4 cutting table	طَاوَلَة (بَنَك) قَصَر القِمَاش
5 model dress	ثَوْب يَسْتخدِم كَمُوْدِيل
6 dressmaker's model (dressmaker's dummy, dress form)	مَانِيكَاَن الخِيَّاطِ (دَامِيَة الخِيَّاط)
7 model coat	مِغْطَف مَعْرُوض عَلى المَانِيكَاَن
8 sewing machine	مَآكِيَة الخِيَّاطَة
9 drive motor	مُوْتور تَشغِيل المَآكِيَة
10 drive belt	سَبِيْر الإِدَارَة
11 treadle	دَوَاسَة المَآكِيَة
12 sewing machine cotton (sewing machine thread) [on bobbin]	خِطْم مَآكِيَة الخِيَّاطَة [عَلى بُوْبِيْنَة]
13 cutting template	مَسطَرَة الخِيَّاط
14 seam binding	شَرِيْط تَنْظِيْف، كَفَّة الدُرُز
15 button box	عَلْبَة الأَزْرَار
16 remnant	قَصَاصَة قِمَاش
17 movable clothes rack	شَمَاعَة مَلايِس مَتَحَرَكَة
18 hand-iron press	مِكْبَس يَدَوِي لِكَي بِالخَاِر
19 presser (ironer)	المِكْوَجِي، الكَوْنِي
20 steam iron	مِكْوَاة بِالخَاِر
21 water feed pipe	خَرْطُوم الإِمْدَاد بِالمَاء
22 water container	حَاوِيَة المَاء
23 adjustable-tilt ironing surface	سَطْح كَي قَابِل للإِمَالَة
24 lift device for the iron	جِهَاز رَفِيع المِكْوَاة
25 steam extractor	جِهَاز نَفْث الخَاِر
26 foot switch controlling steam extraction	مِفْتَاح يَشغَل بِالقَدَم لِلتَحكِم فِي نَفْث الخَاِر
27 pressed non-woven woollen (<i>Am. woolen</i>) fabric	نَسِيْج صَوْفِي مَكْوَبِي لَمْ يَحَاك بَعْد
104 Tailor	المُتَرَزِي
1-32 tailor's workroom	مَشْغَل المُتَرَزِي
1 triple mirror	مِرَاة ثَلَاثِيَة الأَرْجَة
2 lengths of material	أَطْوَال القِمَاش
3 suiting	قِمَاش البِدَال
4 fashion journal (fashion magazine)	مَجَلَة أَرْيَاء
5 ashtray	مِقْبَضَة رَمَاد السِجَاَر
6 fashion catalogue	كِتَابُوح أَرْيَاء
7 workbench	طَاوَلَة (بَنَك) الشغَل
8 wall shelves (wall shelf unit)	أَرْفَف حَاظِلِيَة
9 cotton reel	بِكْرَة خِيَّاط

10 small reels of sewing silk	بِكْرَات صَغِيرَة مَن خِيَّاط حَرِيرِي الحَيَاكَة
11 hand shears	مَقْصَر يَدَوِي
12 combined electric and treadle sewing machine	مَآكِيَة خِيَّاطَة تَعْمَل بِمُوْتور وَدَوَاسَة
13 treadle	الدَوَاسَة مَآكِيَة الخِيَّاطَة
14 dress guard	وَقَاء الثَوْب مِن عَجَلَة المَآكِيَة
15 band wheel	عَجَلَة بَسِير
16 bobbin thread	خِيَّاط مَلْفُوف عَلى بِكْرَة المَآكِيَة
17 sewing machine table	طَاوَلَة (سَطْح) مَآكِيَة الخِيَّاطَة
18 sewing machine drawer	دَرَج مَآكِيَة الخِيَّاطَة
19 seam binding	شَرِيْط تَنْظِيْف، كَفَّة الدُرُز
20 pincushion	وَسَادَة الدِبَابِيْس
21 marking out	تَعْلِيم القِمَاش بِالمِطَاشِير
22 tailor	تَرَزِي
23 shaping pad	وَسَادَة التَشكِيْل
24 tailor's chalk (French chalk)	طِباشِير التَرَزِي
25 workpiece	قِطْعَة الشغَل
26 steam press (steam pressing unit)	مِكْبَس الكَي بِالخَاِر
27 swivel arm	ذِرَاع دَوَار
28 pressing cushion (pressing pad)	وَسَادَة الكَي
29 iron	مِكْوَاة
30 hand-ironing pad	وَسَادَة الكَي اليَدَوِي (يَدُون طَاوَلَة)
31 clothes brush	فُرْشَاة مَلايِس
32 pressing cloth	قِمَاش الكَي (فُونْدَرَة)
105 Ladies' Hairdresser	مُصَفِّف شَعْر المُسَيِّدَات
1-39 ladies' hairdressing salon and beauty salon (<i>Am. beauty parlor, beauty shop</i>)	صَالُون تَصْفِيْف شَعْر المُسَيِّدَات وَصَالُون التَجْمِيل
1-16 hairdresser's tools	أَبْوَات مُصَفِّف الشَعْر
1 bowl containing bleach	زَبْدِيَة تَحْتَوِي عَلى مَادَة التَبْيِيض / التَنْقِيْر
2 detangling brush	فُرْشَاة قَرْد الشَعْر المُتَشَابِك
3 bleach tube	أَنْبُوب مَادَة التَبْيِيض
4 curler [used in dyeing]	أَدَاة لَف الشَعْر [تَسْتخدِم فِي صِيَاغَة الشَعْر]
5 curling tongs (curling iron)	مِكْوَاة تَجْعِد الشَعْر
6 comb (back comb, side comb)	مِشْط
7 haircutting scissors	مَقْصَر تَقْصِير الشَعْر
8 thinning scissors (<i>Am. thinning shears</i>)	مَقْصَر تَخْفِيْف الشَعْر
9 thinning razor	شِفْرَة تَخْفِيْف الشَعْر
10 hairbrush	فُرْشَاة شَعْر
11 hair clip	دَبُوس شَعْر
12 roller	رُول لَف الشَعْر
13 curl brush	فُرْشَاة تَجْعِد الشَعْر
14 curl clip	دَبُوس تَجْعِد الشَعْر

15 dressing comb	مِشْط تَصْفِيْف الشَعْر
16 stiff-bristle brush	فُرْشَاة الشَعْر الخَشِن
17 adjustable hairdresser's chair	كُرْسِي مُصَفِّف الشَعْر القَابِل لِلتَعْدِيل
18 footrest	مِسْنَد القَدَمِيْن
19 dressing table	المُرْتَبَة، مَقْضِدَة التَوَالِيْت
20 salon mirror (mirror)	مِرَاة الصَالُون
21 electric clippers	مَآكِيَة قَص الشَعْر الكَهْرِبَائِيَة
22 warm-air comb	مِشْط الهَوَاء السَاخِن
23 hand mirror (hand glass)	مِرَاة يَدَوِيَة
24 hairspray (hair-fixing spray)	مِرْسِيَة رَدَاز تَثْبِيْت تَسْرِيحَة الشَعْر
25 drier, n swivel-mounted drier	مُجَفِّف الشَعْر (مُثَبَّت عَلى مِجْوَر دَوَارِي)
26 swivel arm of the drier	ذِرَاع دَوَار يَحْمِل المُجَفِّف
27 round base	قَاعَة مَسْتَدِيرَة
28 shampoo unit	وَحْدَة غَسِيْل الشَعْر بِالمِشَامِيُو
29 shampoo basin	حَوْض غَسِيْل الشَعْر بِالمِشَامِيُو
30 hand spray (shampoo spray)	رَشَاش يَدَوِي (لِلشَامِيُو)
31 service tray	صِيْبِيَة الأَدْوَات
32 shampoo bottle	قَبِيْطَة الشَامِيُو
33 hair drier (hand hair drier, hand-held hair drier)	مُجَفِّف الشَعْر (سَتُوَار)
34 cape (gown)	مِرْبَلَة، غِطَاء
35 hairdresser	مُصَفِّفَة الشَعْر
36 perfume bottle	قَبِيْطَة عَطْر
37 bottle of toilet water	قَبِيْطَة مَاء تَوَالِيْت
38 wig	شَعْر مُسْتَعَار (بَاروكَة)
39 wig block	حَامِل البَاروكَة
106 Men's Hairdresser (Barber)	صَالُون جِلَاقَة لِلرُجَال (الحلاق)
1-42 men's salon (men's hairdressing salon, barber's shop, <i>Am. barbershop</i>)	صَالُون حِلَاقَة لِلرُجَال، صَالُون مُصَفِّف شَعْر الرُجَال، حِلَاق الرُجَال
1 hairdresser (barber)	مُصَفِّف شَعْر (حِلَاق)
2 overalls (hairdresser's overalls)	مِرْبَلَة مُصَفِّف الشَعْر
3 hairstyle (haircut)	قِصَة الشَعْر
4 cape (gown)	مِرْبَلَة (عِيَاءَة)
5 paper towel	مِشْطَة وَرْقِيَة
6 salon mirror (mirror)	مِرَاة الصَالُون
7 hand mirror (hand glass)	مِرَاة يَدَوِيَة
8 light	مِصَابِيْح إِضَاءَة
9 toilet water	مَاء تَوَالِيْت
10 hair tonic	مَقُو لِلشَعْر
11 shampoo unit	وَحْدَة غَسِيْل الشَعْر بِالمِشَامِيُو
12 shampoo basin	حَوْض غَسِيْل الشَعْر بِالمِشَامِيُو
13 hand spray (shampoo spray)	رَشَاش يَدَوِي (لِلشَامِيُو)
14 mixer tap (<i>Am. mixing</i>)	خِلَاط المَاء السَاخِن

faucet)	والبارد
15 sockets, e.g. for hair drier	قَابِس كَهْرِبِي (لِلْمُجَفِّف الشَعْر مَثَلًا)
16 adjustable hairdresser's chair (barber's chair)	كُرْسِي مُصَفِّف الشَعْر القَابِل لِلتَعْدِيل
17 height-adjuster bar (height adjuster)	قَضِيْب تَعْدِيل ارتفاع الكُرْسِي
18 armrest	مِسْنَد الذراع
19 footrest	مِسْنَد القَدَمِيْن
20 shampoo	شَامِيُو
21 perfume spray	مِرْسِيَة العَطْر
22 hair drier (hand hair drier, hand-held hair drier)	مُجَفِّف الشَعْر، مُجَفِّف شَعْر يَدَوِي (سَتُوَار)
23 setting lotion in a spray can	غَسُول تَثْبِيْت الشَعْر فِي مِرْسِيَة
24 hand towels for drying hair	مِثَافَة يَدَوِيَة لِتَجْفِيْف الشَعْر
25 towels for face compresses	مِثَافَة تَسْتخدِم كَمَمَادَات لِلوَجْه
26 crimping iron	مِكْوَاة الشَعْر لِلتَجْعِيد أَو التَمْوِيْج
27 neck brush	فُرْشَاة إِزَالَة الشَعْر المَحْلُوق مِن عَلى الرِقْبَة
28 dressing comb	مِشْط تَصْفِيْف الشَعْر
29 warm-air comb	مِشْط الهَوَاء السَاخِن
30 warm-air brush	فِرَاقَة الهَوَاء السَاخِن
31 curling tongs (hair curler, curling iron)	مِكْوَاة الشَعْر (لِلتَجْعِيد)
32 electric clippers	مَآكِيَة قَص الشَعْر الكَهْرِبَائِيَة
33 thinning scissors (<i>Am. thinning shears</i>)	مَقْصَر تَخْفِيْف الشَعْر
34 haircutting scissors; <i>sim.</i> : styling scissors	مَقْصَر تَقْصِير الشَعْر
35 scissor-blade	نِصْل المَقْصَر
36 pivot	مِجْوَر المَقْصَر
37 handle	مِقْبِض المَقْصَر
38 open razor (straight razor)	بِشْفَرَة حِلَاقَة مَفْتُوحَة
39 razor handle	مِقْبِض شِفْرَة الحِلَاقَة
40 edge (cutting edge, razor's edge, razor's cutting edge)	حَافَة حَادَة
41 thinning razor	شِفْرَة تَخْفِيْف الشَعْر
42 diploma	دِبْلُوم، شَهَادَة
107 Tobacco and Smoking Requisites	التَبَاق وَلَوَازِم التَدَخُّيْن
1 cigar box	صندوق السِجَاَر/السِكَاَر
2 cigar; <i>kinds</i> : Havana cigar (Havana), Brazilian cigar, Sumatra cigar	سِجَاَر · أنواعه سِجَاَر هَاْفَانِي، سِجَاَر بَرَاذِيْلِي، سِجَاَر سُوْمَطْرِي
3 cigarillo	سِجَاَرِيْلُو (نوع مِن السِجَاَر)
4 cheroot	شِيرُوت (سِجَاَر مَفْتُوح الطَرَفِيْن)

5 wrapper	لغافة
6 binder	غلاف
7 filler	حشوة
8 cigar case	علبة سيجار
9 cigar cutter	أداة قطع طرف لغافة السيجار من الخلف
10 cigarette case	علبة سجاائر
11 cigarette packet (<i>Am. pack</i>)	علبة سجاائر (من الكرتون)
12 cigarette, a filter-tipped cigarette	سيجارة (بغم فلتر)
13 cigarette tip; <i>kinds:</i> cork tip, gold tip	قُم السيجارة: أنواعه فليني ومذهب
14 Russian cigarette	سيجارة روسي
15 cigarette roller	ماكينة لف السجاائر
16 cigarette holder	ميسم سيجارة
17 packet of cigarette papers	لغافة ورق سجاائر
18 pigtail (twist of tobacco)	تَبَع مَجْدُول في شكل لغافة
19 chewing tobacco; a piece: plug (quid, chew)	تَبَع للمَضغ: القطعة مَضَغَة
20 snuff box, containing snuff	صندوق سَعوط وبه شُوق
21 matchbox	علبة كبريت/تقاب
22 match	عود تقاب
23 head (match head)	رأس العود
24 striking surface	سطح الإشعال (شطاطة)
25 packet of tobacco; <i>kinds:</i> fine cut, shag, navy plug	علبة تَبَع: أنواعه قطع فاخر، مفروم، قُرص مضغوط
26 revenue stamp	طابع تَمغَة
27 petrol cigarette lighter (petrol lighter)	قَدَاحَة/ولاعة سجاائر تعمل بالبنزين
28 flint	حجر القَدَاحَة/الولاعة
29 wick	قنبل
30 gas cigarette lighter (gas lighter), a disposable lighter	قَدَاحَة/ولاعة سجاائر تعمل بالغاز
31 flame regulator	مَنْظَم حجْم اللهب
32 chibonk (chibonque)	الشَبِق، غَلْيُون تركي
33 short pipe	غَلْيُون قصير
34 clay pipe (Dutch pipe)	غَلْيُون من الصلصال (غَلْيُون هولندي)
35 long pipe	غَلْيُون طويل
36 pipe bowl (bowl)	رأس/دَوَايَة الغَلْيُون
37 bowl lid	غطاء الدَوَايَة
38 pipe stem (stem)	ساق/أَنْبُوب الغَلْيُون
39 briar pipe	غَلْيُون من جذر الكُنْج الشجري
40 mouthpiece	ميسم الغَلْيُون
41 sand-blast finished or polished briar grain	غَلْيُون مصقول مصنوع من جذر الكُنْج الشجري
42 hookah (narghile, narghileh), a water pipe	شيشة، نَرْجيلة
43 tobacco pouch	كيس التَبَع
44 smoker's companion	عدة المدخّن
45 pipe scraper	أداة كشط لتنظيف الغَلْيُون
46 pipe cleaner	أداة تنظيف لتسليك الغَلْيُون
47 tobacco presser	أداة كَيْس التَبَع

48 pipe cleaner	أداة تنظيف الغَلْيُون
108 Goldsmith, Silversmith	الصَّائِغ (صائغ الذهب والفضة)
1 wire and sheet roller	ماكينة لف السلك والصفائح
2 drawbench (drawing bench)	طاولة الرَّسَم
3 wire (gold or silver wire)	سلك (سلك ذهب أو فضة)
4 archimedes drill (drill)	مِقْطَاب أرخميدي
5 crossbar	عارضة المقتاب
6 suspended (pendant) electric drilling machine	آلة ثَقْب كهربائية مَعْلَقَة
7 spherical cutter (cherry)	قاطع كُرَوِي
8 melting pot	بَوَيْقَة الانصهار
9 fireclay top	غِطَاء من الطين الحراري
10 graphite crucible	بَوَيْقَة من الغرافيت
11 crucible tongs	مِلْطَق البَوَيْقَة
12 piercing saw (jig saw)	مِشْطَار أَرْكْت
13 piercing saw blade	نصل مِشْطَار الأَرْكْت
14 soldering gun	مَسْطَس لحام
15 thread tapper	أداة حَز اللولب
16 blast burner (blast lamp) for soldering	مَوْجِد لحام
17 goldsmith	صائغ
18 swage block	زَهْرَة طرق
19 punch	سَنَك
20 workbench (bench)	طاولة الشغل
21 bench apron	غِطَاء واق للطاولة
22 needle file	مِيزِد إبري
23 metal shears	مقص معادن
24 wedding ring sizing machine	ماكينة ضبط مقاسات خاتم الزواج
25 ring gauge (<i>Am. gage</i>)	مقياس الخواتم
26 ring-rounding tool	أداة تدوير الخواتم
27 ring gauge (<i>Am. gage</i>)	مقياس الخواتم
28 steel set-square	مثلث رسم معدني قائم الزاوية
29 (circular) leather pad	وسادة جِلْدِيَة (دائرية)
30 box of punches	صندوق السناك
31 punch	سَنَك
32 magnet	مغناطيس
33 bench brush	قُرْشَة طاولة الشغل
34 engraving ball (joint vice, clamp)	كرة النقش لِحَفَر الكليشيه (قائمة مفصلة)
35 gold and silver balance (assay balance), a precision balance	ميزان الذهب والفضة، ميزان حساس
36 soldering flux (flux)	ضَهْور لحام
37 charcoal block	قطعة فحم نباتي للحام
38 stick of solder	سِيق لحام
39 soldering borax	بُورَق لحام
40 shaping hammer	مطرقة تشكيل
41 chasing (enchasing) hammer	مطرقة ترصيع وزخرفة
42 polishing and burnishing machine	ماكينة صقل وتلميع
43 dust exhauster (vacuum)	جهاز طرد الأتربة

cleaner	عَجَلَة الصقل
44 polishing wheel	عَجَلَة الصقل
45 dust collector (dust catcher)	حاجز الأتربة
46 buffing machine	ماكينة تلميع
47 round file	مِيزِد دائري المَقَطع
48 bloodstone (haematite, hematite)	حَجَر الدَّم (هيماتيت)
49 flat file	مِيزِد مسطح
50 file handle	مِقْبَض المِيزِد
51 polishing iron (burnisher)	قضيب تلميع (مبمقل)
109 Watchmaker, Clockmaker	السَّاعَاتِي
1 watchmaker; <i>also:</i> clockmaker	ساعاتي
2 workbench	طاولة الشغل
3 armrest	مِسَد للذراع
4 oiler	مِرْبِيَة
5 oil stand	حامل الزيت
6 set of screwdrivers	طاقم مفكات
7 clockmaker's anvil	سِدَّان الساعاتي
8 broach, a reamer	مِقْطَاب، مِسْطَل، مَوْسَع تقوُب
9 spring pin tool	أداة تركيب ونزع المسامير
10 hand-removing tool	الزوردة بناهض
11 watchglass-fitting tool	أداة فِصْل عِقَارِب السَّاعَة
12 workbench lamp, a multi-purpose lamp	أداة تركيب زجاجة السَّاعَة مصباح طاولة الشغل، مصباح متعدد الأغراض
13 multi-purpose motor	موتور متعدد الأغراض
14 tweezers	ملقاط
15 polishing machine attachments	ملفاتن ماكينة الصقل والتلميع
16 pin vice (pin holder)	ماسك المسامير
17 burnisher, for burnishing, polishing, and shortening of spindles	ماكينة صقل وتلميع وتصغير المحاور
18 dust brush	قُرْشَة تنظيف التراب
19 cutter for metal watch straps	أداة قطع سَوَار السَّاعَة المعدني
20 precision bench lathe (watchmaker's lathe)	مِخْرَطَة دقيقة (مِخْرَطَة الساعاتي)
21 drive-belt gear	تُرْس يعمل بسير
22 workshop trolley for spare parts	ترولي قطع العيار بالورشة
23 ultrasonic cleaner	جهاز تنظيف بالاهتزازات فوق الصوتية
24 rotating watch-testing machine for automatic watches	ماكينة دَوَارَة لاختبار الساعات الآلية
25 watch-timing machine for electronic components	ماكينة توقيت الساعات الخاصة بالأجزاء الإلكترونية
26 testing device for waterproof watches	جهاز اختبار الساعات المقاومة للماء
27 electronic timing machine	ماكينة توقيت إلكترونية

28 vice (<i>Am. vise</i>)	مَلْزَمَة
29 watchglass-fitting tool for armoured (<i>Am. armored</i>) glasses	ماكينة تركيب زجاجة السَّاعَة المَدْرَعَة
30 [automatic] cleaning machine for conventional cleaning	ماكينة تنظيف آلية للتنظيف العادي
31 cuckoo clock (Black Forest clock)	ساعة مَعْرَدَة
32 wall clock (regulator)	ساعة حائط
33 compensation pendulum	بندول السَّاعَة
34 kitchen clock	ساعة المطبخ
35 timer	جهاز توقيت
110 Clocks and Watches	السَّاعَات
1 electronic wristwatch	ساعة يد إلكترونية
2 digital display (a light-emitting diode (LED) display; <i>also:</i> a liquid crystal display, LCD)	شاشة عَرْض رَقْمِيَة، أيضاً شاشة عرض بلوري سائل
3 hour and minute button (on 6, also for setting the analogue (<i>Am. analog</i>) display)	زَرْضِيب الساعات والدقائق (في رقم 6 يُسْتخدَم أيضاً لضبط شاشة العرض التماثلية)
4 date and second button	زَرْضِيب التاريخ والثواني
5 strap (watch strap)	طوق/سوار السَّاعَة
6 multifunction electronic watch	ساعة إلكترونية متعددة الاستخدامات
7 analogue (<i>Am. analog</i>) display	شاشة عرض تماثلية
8 alarm button	زَرْ المنبه
9 stopwatch button	زَرْ سَّاعَة الإيقاف
10 rotating bezel (time-lapse indicator ring)	قُرْص دَوَار (قُرْص تحديد الزمن المنقضي)
11 calendar clock (alarm clock)	ساعة بنتيجة (ساعة بجرس منبه)
12 digital display with flip-over numerals	شاشة عَرْض رَقْمِي بها أرقام قابلة
13 alarm indicator	مؤشر المنبه
14 stop button	زَرْ إيقاف جرس المنبه
15 forward and backward wind knob	ذراع التقديم والتأخير
16 grandfather clock	ساعة قائمة
17 face	وَجْه السَّاعَة
18 clock case	صندوق السَّاعَة
19 pendulum	بندول السَّاعَة
20 striking weight	ثَقْل دَقَات السَّاعَة
21 time weight	ثَقْل الوقت
22 sundial	المِرْوَلَة، ساعة شمسية
23 hourglass (egg timer)	ساعة رَمْلِيَة
24-35 components of an automatic watch (automatic wristwatch, self-winding watch)	مَكُونَات ساعة يد آلية
24 weight (rotor)	ثَقْل (رَفَاص)
25 stone (jewel, jewelled bearing) a synthetic	حجر كريم، ياقوت صناعي

microscope	أُتُوب قطع الضوئية
38 light section tube	جريدة مسننة ومسننة
39 rack and pinion	صغيرة
40 zoom stereomicroscope	مجهز مجسم ذو عدسة زوم
41 zoom lens	عدسة زوم
42 dust counter	كاونتر الأتربة
43 measurement chamber	حجرة القياس
44 data output	خروج البيانات
45 analogue (Am. analog) output	خروج تماثلي
46 measurement range selector	ذراع اختيار قياس المدى
47 digital display (digital readout)	شاشة عرض رقمية
48 dipping refractometer for examining food	مقياس انكسار غاطس لفحص الطعام
49 microscopic photometer	فوتومتر مجهري
50 photometric light source	مصدر ضوء فوتومتري
51 measuring device (photomultiplier, multiplier phototube)	جهاز قياس (مضاعف ضوئي إلكتروني، مضامض ضوئي مضاعف)
52 light source for survey illumination	مصدر ضوء لإنارة المسح الحظلي
53 remote electronics	وحدة إلكترونيات يتم تشغيلها عن بعد
54 universal wide-field microscope	مجهز واسع الحقل متعدد الأغراض
55 adapter for camera or projector attachment	مهايئ لوصلة كاميرا أو فنانوس إسقاط (بروجكتور)
56 eyepiece focusing knob	مفتاح إحكام العينية
57 filter pick-up	لاقط المرشح
58 handrest	مسند اليد
59 lamphouse for incident (vertical) illumination	مقر المصابيح الخاصة بالإضاءة الساقطة (العمودية)
60 lamphouse connector for transillumination	قارئة مقر المصابيح للإضاءة المتبادلة
61 wide-field stereo-microscope	مجهز مجسم واسع الحقل
62 interchangeable lenses (objectives)	عدسات (شبيئية) قابلة للإبدال فيما بينها
63 incident (vertical) illumination (incident top lighting)	مصدر الضوء الساقط (ضوء علوي ساقط)
64 fully automatic microscope camera, camera with photo-micro mount adapter	كاميرا مجهزة تعمل أليا بالكامل
65 film cassette	كاسيت الفيلم
66 universal condenser for research microscope	مكثف متعدد الأغراض لمجهز الأبحاث
67 universal-type measuring machine for photogrammetry (photo-theodolite)	آلة قياس من النوع الجامع خاصة بالتصوير المساحي الجوى
68 photogrammetric	كاميرا فوتوجرامترية

والأبحاث، "نظام لايتز"
حامل
قاعدة
مقبض المسدّد التقريبي
مقبض الضبط الدقيق
مسار الحزمة الضوئية
بصريات ضوئية
مكثف
مبصرة الميكرو سكوب
مبصرة ميكانيكية
برج جسمية المجهز (برج دوار متعدد العدسات لفحص العينة المجهريّة)
رأس ذات عيّتين
مناشير تقريظ أشعة الحزمة الضوئية
مجهز/ميكرو سكوب الضوء النافذ مزود بكاميرا ومستقطب (نظام "زايس")
قاعدة المبنصة
شريحة منزقة ذات ثقب
مبصرة جامع/متعددة الأغراض
لوحة العدسات
مرشح استقطابي
كاميرا
شاشة التركيز البوري
ترتيبة صمام الفحص
مجهز معدني واسع الحقل، مجهز الضوء المنعكس
حاجز مطأ للمعة (حاجز من الزجاج المنصفر)
كاميرا ضخمة البيان
كاميرا مصغرة
لوح القاعدة
بيت المصابيح
مبصرة ميكانيكية
برج جسمية المجهز (برج دوار متعدد العدسات لفحص العينة المجهريّة)
مجهز جراحي
حامل قائم
إضاءة المجال
مجهز تصويري
كاسيت فيلم صغير
وصلة كاميرا تصوير
مجهزى كاميرا ضخمة البيان أو كاميرا تلفزيونية
مجهز مستوى السطح

microscope, Leitz system
2 stand
3 base
4 coarse adjustment
5 fine adjustment
6 illumination beam path (illumination path)
7 illumination optics
8 condenser
9 microscope (microscopic, object) stage
10 mechanical stage
11 objective turret (revolving nosepiece)
12 binocular head
13 beam-splitting prisms
14 transmitted-light microscope with camera and polarizer, Zeiss system
15 stage base
16 aperture-stop slide
17 universal stage
18 lens panel
19 polarizing filter
20 camera
21 focusing screen
22 discussion tube arrangement
23 wide-field metallurgical microscope, a reflected-light microscope (microscope for reflected light)
24 matt screen (ground glass screen, projection screen)
25 large-format camera
26 miniature camera
27 base plate
28 lamphouse
29 mechanical stage
30 objective turret (revolving nosepiece)
31 surgical microscope
32 pillar stand
33 field illumination
34 photomicroscope
35 miniature film cassette
36 photomicrographic camera attachment for large-format or television camera
37 surface-finish

منظار ذو عيّتين
تليسكوب وحيد العينية
ميكروسكوب، مجهز ورتبة المنظاراتي
طاولّة الشغل
جهاز تحديد المركز عام الأخرى
حامل شفاط تحديد المركز
شفاط
ماكينة تحفييف
قالب التشكيل الخاصة بماكينة تحفييف العدسات
قالب تشكيل مركب بالماكينة
طابعة دّارة
عجلة التلجيج
وحدة التحكم
جزء الماكينة
أُتُوب ماء التبريد
محلّو التلجيف
مقياس الضبط البؤري
جهاز قولية معدنية
مجموعة عجلة التلجيج وفورمات ضبط الحواف
عجلة تخضين للسطح الأولية
المبصّلة الدقيقة لأسطح العدسات الموجبة والسالبة
المبصّلة الدقيقة للعدسات الخاصة والمستوية
عدسة مقعرة مستوية ذات سطح مسطح
عدسة مقعرة مستوية ذات سطح خاص
عدسة مقعرة ومحدّبة ذات سطح خاص
عدسة محدّبة ومقعرة ذات سطح خاص
جهاز فحص العين
فروبر مع جهاز فحص قاع العين (مكشاف) وجهاز قياس مدى الإبصار (مبصار)
حقيقية عدسات التجريب
موجة الأشعة، المسددة
بروجكتور حدة الرؤية
الألات البصريّة (I)
ميكروسكوب المُختبّر

17 binoculars
18 monocular telescope (tube)
19 microscope
20-47 optician's workshop
20 workbench
21 universal centring (centering) apparatus
22 centring (centering) suction holder
23 sucker
24 edging machine
25 formers for the lens edging machine
26 inserted former
27 rotating printer
28 abrasive wheel combination
29 control unit
30 machine part
31 cooling water pipe
32 cleaning fluid
33 focimeter (vertex refractionometer)
34 metal-blocking device
35 abrasive wheel combination and forms of edging
36 roughing wheel for preliminary surfacing
37 fining lap for positive and negative lens surfaces
38 fining lap for special and flat lenses
39 plano-concave lens with a flat surface
40 plano-concave lens with a special surface
41 concave and convex lens with a special surface
42 convex and concave lens with a special surface
43 ophthalmic test stand
44 phoropter with ophthalmometer and optometer (refractometer)
45 trial lens case
46 collimator
47 acuity projector
112 Optical Instruments (I)
1 laboratory and research

ruby	سقاطة
26 click	فُرْس السقاطة
27 click wheel	فُرْس السقاطة
28 clockwork (clockwork mechanism)	آلية الساعة
29 bottom train plate	اللوح السفلية لتثبيت القروس
30 spring barrel	فُرْس زنبركي
31 balance wheel	فُرْس موازنة
32 escape wheel	فُرْس الانفلات المنتظم
33 crown wheel	فُرْس إبريز ملء الساعة
34 winding crown	إبريز ملء الساعة
35 drive mechanism	آلية الدفع/الإدارة
36 principle of the electronic quartz watch	قاعدة ساعة الكوارتز الإلكترونية
37 quartz	بلورة الكوارتز
38 power source (a button cell)	مصدر طاقة (بطارية جافة)
39 hour hand	عقرب الساعات
40 minute hand	عقرب الدقائق
41 wheels	قروس
42 stepping motor (stepper motor)	موتور التدرّيج
43 frequency divider (integrated circuit)	مقسّم التردد (دائرة متكاملة)
44 decoder	ديكودر (جهاز فك الرموز)
111 Optician	أخصائي البصريّات، المنظاراتي
1-19 sales premises	محل البيع
1-4 spectacle fitting	تجربة الإطارات لاختيار النظارة
1 optician	أخصائي البصريّات، المنظاراتي
2 customer	زبون
3 trial frame	إطار التجريب
4 mirror	مرآة
5 stand with spectacle frames (display of frames, range of spectacles)	حامل عرض إطارات النظارات
6 sunglasses (sun spectacles)	نظارات شمسية
7 metal frame	إطار معدني (شبيّر معدني)
8 tortoiseshell frame (shell frame)	إطار /شبيّر ذلي (بأغة)
9 spectacles (glasses)	عويّات (نظارات)
10-14 spectacle frame	إطار/شبيّر النظارة
10 fitting (mount) of the frame	مُثَبّط إطار النظارة
11 bridge	جسر الإطار (كوبري الإطار)
12 pad bridge	وسادة قضبة الأنف
13 side	ذراع النظارة
14 side joint	مفصل ذراع النظارة
15 spectacle lens, bifocal lens	عدسة النظارة، عدسة ازدواجية البؤرة
16 hand mirror (hand glass)	مرآة يدوية

cameras	كبيره البيان
62 meter	عداد
63 probe	مستأبر
64 dark slide	شريحة قاتمة
65 battery-portable electronic flash (battery-portable electronic flash unit)	فلاش إلكتروني محمول يعمل بالبطارية
66 power pack unit (battery)	وحدة حزمة الطاقة
67 flash head	رأس الفلاش
68 single-unit electronic flash (flashgun)	فلاش إلكتروني من وحدة مفردة
69 swivel-mounted reflector	عاكس مثبت على محور دوّراتي
70 photodiode	صمام ثنائي ذو توصيلية ضوئية
71 foot	قدم، قاعدة
72 hot-shoe contact	نقطة التماس الساخن
73 flash cube unit	وحدة مكعب الفلاش
74 flash cube	مكعب الفلاش
75 flash bar (AGFA)	لوح الفلاشات (أجفا)
76 slide projector	جهاز عرض الشرائح
77 rotary magazine	علبة دوارة

المصوّير (2)

115 Photography II	نظام الكاميرا (كاميرا آلية صغيرة عاكسة مفردة العدسة)
1-24 system camera	نظام الكاميرا (كاميرا آلية صغيرة عاكسة مفردة العدسة)
(fully automatic miniature single-lens reflex camera)	
1 main switch	مفتاح التشغيل الرئيسي
2 function adjustment button (to set exposure adjustment value, drive mode, and focus area)	زر ضبط الوظيفة (لضبط قيمة تعديل تعريض الفيلم للضوء، ونمط الإدارة، ونطاق التركيز البؤري)
3 exposure mode button	زر نمط تعريض الفيلم للضوء
4 accessory shoe	حذاء تركيب الملحقات
5 program reset button	زر إعادة ضبط البرنامج
6 data panel (data monitor, data display)	لوحة البيانات
7 card on/off key	زر تشغيل/إيقاف البطاقة
8 function selector key	مفتاح اختيار الوظيفة
9 chip program card	بطاقة برنامج رقائعية
10 card door	باب إدخال البطاقة
11 card window	شباك البطاقة
12 battery chamber	حجرة البطارية
13 remote control terminal	طرفية التحكم عن بعد
14 shutter release (shutter release button)	زر تحرير مغلاق العدسة
15 autofocus (AF) illuminator and self-timer light	مؤشر ضوئي للإحكام الآلي للبوارة وضوء جهاز التوقيت الذاتي
16 manual shutter control [up/down control]	التحكم يدويًا في مغلاق العدسة
17 reflex mirror	مرآة عاكسة
18 autofocus sensor, a CCD image converter (image sensor)	خلية استشعار آلية البوارة

غطاء عينية رؤية المنظر	غطاء عينية رؤية المنظر
قابل للطي	قابل للطي
خلية مترية	خلية مترية
عدسة رؤية	عدسة رؤية
عدسة شبيبة	عدسة شبيبة
مقبض البكرة	مقبض البكرة
حلقة ضبط المسافة	حلقة ضبط المسافة
مقياس مدة التعريض	مقياس مدة التعريض
للضوء باستخدام نظام مطابقة الإبرة	للضوء باستخدام نظام مطابقة الإبرة
موضع توصيل الفلاش	موضع توصيل الفلاش
زر تحرير مغلاق العدسة	زر تحرير مغلاق العدسة
لف الفيلم للأمام	لف الفيلم للأمام
زر تشغيل الفلاش	زر تشغيل الفلاش
زر ضبط فتحة العدسة	زر ضبط فتحة العدسة
زر التحكم في سرعة المغلاق	زر التحكم في سرعة المغلاق
كاميرا تصوير صحفي	كاميرا تصوير صحفي
مقبض مسك الكاميرا	مقبض مسك الكاميرا
زر تحرير الكيل	زر تحرير الكيل
حلقة ضبط المسافة	حلقة ضبط المسافة
نافذة تحديد المدى	نافذة تحديد المدى
عينية رؤية جامعة	عينية رؤية جامعة
حامل ثلاثي	حامل ثلاثي
ساق الحامل الثلاثي	ساق الحامل الثلاثي
ساق أنبوبية	ساق أنبوبية
قدم مطاطية	قدم مطاطية
العمود المركزي	العمود المركزي
رأس ذو كرة وحق	رأس ذو كرة وحق
كفة كاميرا تصوير سينمائي	كفة كاميرا تصوير سينمائي
ذات رأس مائل	ذات رأس مائل
كاميرا كبيرة البيان قابلة للطي	كاميرا كبيرة البيان قابلة للطي
منصة بصرية ضوئية	منصة بصرية ضوئية
زر ضبط الحامل العمودي	زر ضبط الحامل العمودي
الحامل العمودي للعدسة	الحامل العمودي للعدسة
مفتاح الكاميرا	مفتاح الكاميرا
ظهر الكاميرا	ظهر الكاميرا
زر ضبط الحامل الخلفي	زر ضبط الحامل الخلفي
مقياس يدوي لحساب مدة التعريض للضوء	مقياس يدوي لحساب مدة التعريض للضوء
قرص حاسبي	قرص حاسبي
مقياس مدرج ذو مؤشر	مقياس مدرج ذو مؤشر
مفتاح ضبط المدى	مفتاح ضبط المدى
ناشرة لقياس الضوء الساقط	ناشرة لقياس الضوء الساقط
مقياس مستأبري لمدة التعرض للضوء للكاميرات	مقياس مستأبري لمدة التعرض للضوء للكاميرات

23 folding viewfinder	مظنّن رؤية
hood (focusing hood)	غطاء عينية رؤية المنظر
24 meter cell	خلية مترية
25 viewing lens	عدسة رؤية
26 object lens	عدسة شبيبة
27 spool knob	مقبض البكرة
28 distance setting (focus setting)	حلقة ضبط المسافة
29 exposure meter using needle-matching system	مقياس مدة التعريض للضوء باستخدام نظام مطابقة الإبرة
30 flash contact	موضع توصيل الفلاش
31 shutter release	زر تحرير مغلاق العدسة
32 film transport (film advance, film wind)	لف الفيلم للأمام
33 flash switch	زر تشغيل الفلاش
34 aperture-setting control	زر ضبط فتحة العدسة
35 shutter speed control	زر التحكم في سرعة المغلاق
36 large-format hand camera (press camera)	كاميرا تصوير صحفي
37 grip (handgrip)	مقبض مسك الكاميرا
38 cable release	زر تحرير الكيل
39 distance-setting ring (focusing ring)	حلقة ضبط المسافة
40 rangefinder window	نافذة تحديد المدى
41 multiple-frame viewfinder (universal viewfinder)	عينية رؤية جامعة
42 tripod	حامل ثلاثي
43 tripod leg	ساق الحامل الثلاثي
44 tubular leg	ساق أنبوبية
45 rubber foot	قدم مطاطية
46 central column	العمود المركزي
47 ball and socket head	رأس ذو كرة وحق
48 cine camera pan and tilt head	كفة كاميرا تصوير سينمائي ذات رأس مائل
49 large-format folding camera	كاميرا كبيرة البيان قابلة للطي
50 optical bench	منصة بصرية ضوئية
51 standard adjustment	زر ضبط الحامل العمودي
52 lens standard	الحامل العمودي للعدسة
53 bellows	مفتاح الكاميرا
54 camera back	ظهر الكاميرا
55 back standard adjustment	زر ضبط الحامل الخلفي
56 hand-held exposure meter (exposure meter)	مقياس يدوي لحساب مدة التعريض للضوء
57 calculator dial	قرص حاسبي
58 scales (indicator scales) with indicator needle (pointer)	مقياس مدرج ذو مؤشر
59 range switch (high/low range selector)	مفتاح ضبط المدى
60 diffuser for incident light measurement	ناشرة لقياس الضوء الساقط
61 probe exposure meter for large-format	مقياس مستأبري لمدة التعرض للضوء للكاميرات

مجهر القراءة	مجهر القراءة
تلسكوب خط الزوال	تلسكوب خط الزوال
مجهر إلكتروني	مجهر إلكتروني
أنبوب المجهر (جسم المجهر)	أنبوب المجهر (جسم المجهر)
مذبح كهأرب	مذبح كهأرب
مكثفات	مكثفات
دسأم هوائي لإدخال العينات	دسأم هوائي لإدخال العينات
ذراع التحكم في ضبط منضبة العينات	ذراع التحكم في ضبط منضبة العينات
ذراع التحكم الخاصة بفتحات العدسة الشبيبة	ذراع التحكم الخاصة بفتحات العدسة الشبيبة
عدسة الشبيبة	عدسة الشبيبة
الشاشة المتوسطة العاكسة للصورة	الشاشة المتوسطة العاكسة للصورة
مكبر تلسكوبي للصورة	مكبر تلسكوبي للصورة
أنبوب الصورة النهائية	أنبوب الصورة النهائية
حجرة فوتوغرافية لخزانات الأفلام والألواح	حجرة فوتوغرافية لخزانات الأفلام والألواح
المصوّير (1)	المصوّير (1)
كاميرا صغيرة (كاميرا 35 ملم)	كاميرا صغيرة (كاميرا 35 ملم)
عينية رؤية المنظر	عينية رؤية المنظر
خلية مترية	خلية مترية
حذاء تركيب الملحقات	حذاء تركيب الملحقات
عدسة مسطّاحة	عدسة مسطّاحة
ذراع لف الفيلم	ذراع لف الفيلم
كاسيت (علبة فيلم مصغّر)	كاسيت (علبة فيلم مصغّر)
علبة فيلم 135، علبة فيلم 35 ملم)	علبة فيلم 135، علبة فيلم 35 ملم)
بكرة الفيلم	بكرة الفيلم
فيلم ذو دليل وثقوب	فيلم ذو دليل وثقوب
فتحة الكاسيت	فتحة الكاسيت
كاميرا تزود بلقيفة فيلم	كاميرا تزود بلقيفة فيلم
زر تحرير مغلاق العدسة	زر تحرير مغلاق العدسة
موضع توصيل مكعب الفلاش	موضع توصيل مكعب الفلاش
عينية رؤية مستطيلة	عينية رؤية مستطيلة
لقيفة فيلم 126	لقيفة فيلم 126
كاميرا جيب	كاميرا جيب
لقيفة فيلم 110	لقيفة فيلم 110
نافذة الفيلم	نافذة الفيلم
فيلم 120 رولفيلم	فيلم 120 رولفيلم
بكرة الفيلم الملفوف	بكرة الفيلم الملفوف
ورق تغليف	ورق تغليف
كاميرا عاكسة ذات عدسة مزدوجة	كاميرا عاكسة ذات عدسة مزدوجة

28 reading microscope	مجهر القراءة
29 meridian telescope	تلسكوب خط الزوال
30 electron microscope	مجهر إلكتروني
31-39 microscope tube (microscope body, body tube)	أنبوب المجهر (جسم المجهر)
31 electron gun	مذبح كهأرب
32 condensers	مكثفات
33 specimen insertion air lock	دسأم هوائي لإدخال العينات
34 control for the specimen stage adjustment	ذراع التحكم في ضبط منضبة العينات
35 control for the objective apertures	ذراع التحكم الخاصة بفتحات العدسة الشبيبة
36 objective lens	عدسة الشبيبة
37 intermediate image screen	الشاشة المتوسطة العاكسة للصورة
38 telescope magnifier	مكبر تلسكوبي للصورة
39 final image tube	أنبوب الصورة النهائية
40 photographic chamber for film and plate magazines	حجرة فوتوغرافية لخزانات الأفلام والألواح
114 Photography I	المصوّير (1)
1 miniatur camera (35 mm camera)	كاميرا صغيرة (كاميرا 35 ملم)
2 viewfinder eyepiece	عينية رؤية المنظر
3 meter cell	خلية مترية
4 accessory shoe	حذاء تركيب الملحقات
5 flush lens	عدسة مسطّاحة
6 rewind handle (rewind, rewind crank)	ذراع لف الفيلم
7 miniature film cassette (135 film cassette, 35 mm cassette)	كاسيت (علبة فيلم مصغّر)
8 film spool	بكرة الفيلم
9 film with leader and perforations	فيلم ذو دليل وثقوب
10 cassette slit (cassette exit slot)	فتحة الكاسيت
11 cartridge-loading camera	كاميرا تزود بلقيفة فيلم
12 shutter release (shutter release button)	زر تحرير مغلاق العدسة
13 flash cube contact	موضع توصيل مكعب الفلاش
14 rectangular viewfinder	عينية رؤية مستطيلة
15 126 cartridge (instamatic cartridge)	لقيفة فيلم 126
16 pocket camera (sub-miniature camera)	كاميرا جيب
17 110 cartridge (sub-miniature cartridge)	لقيفة فيلم 110
18 film window	نافذة الفيلم
19 120 rollfilm	فيلم 120 رولفيلم
20 rollfilm spool	بكرة الفيلم الملفوف
21 backing paper	ورق تغليف
22 twin-lens reflex camera	كاميرا عاكسة ذات عدسة مزدوجة

ميزان مسأحي يعمل بمحرك	ميزان مسأحي يعمل بمحرك
آلة قياس مسافات كهروبصرية	آلة قياس مسافات كهروبصرية
كاميرا مجسّمة	كاميرا مجسّمة
قاعدة أفقية	قاعدة أفقية
مزواة/ثيودوليت للقياس في الثانية الواحدة	مزواة/ثيودوليت للقياس في الثانية الواحدة
الألات البصريّة (2)	الألات البصريّة (2)
تليسكوب 2,2 ملم عاكس	تليسكوب 2,2 ملم عاكس
قاعدة	قاعدة
مخمل محوري نصف قطري	مخمل محوري نصف قطري
آلية ضبط الميل	آلية ضبط الميل
محور الانحراف الزاوي/الميل	محور الانحراف الزاوي/الميل
مخمل آلية ضبط الميل	مخمل آلية ضبط الميل
اللفة الأمامية	اللفة الأمامية
أنبوب	أنبوب
جزء مركز الأنبوب	جزء مركز الأنبوب
المرآة الرئيسية	المرآة الرئيسية
المرآة الثانوية (مرآة الانحراف)	المرآة الثانوية (مرآة الانحراف)
مخمل شوكة	مخمل شوكة
غطاء	غطاء
مخمل دليلي	مخمل دليلي
وحدة الإدارة الرئيسية للمحور القطبي	وحدة الإدارة الرئيسية للمحور القطبي
مخامل التليسكوب	مخامل التليسكوب
تليسكوب عاكس مثبت على قاعدة من الطراز الألماني	تليسكوب عاكس مثبت على قاعدة من الطراز الألماني
محور الميل	محور الميل
المحور القطبي	المحور القطبي
ثقل موازن	ثقل موازن
عينية	عينية
مخمل مرفقي ذو عمود محثي	مخمل مرفقي ذو عمود محثي
مخمل محوري من الطراز الإنجليزي	مخمل محوري من الطراز الإنجليزي
مخمل مقرون من الطراز الإنجليزي	مخمل مقرون من الطراز الإنجليزي
مخمل شوكة (مشتعّب)	مخمل شوكة (مشتعّب)
مخمل على شكل حدوة الفرس	مخمل على شكل حدوة الفرس
(جهاز) دائرة خط الزوال	(جهاز) دائرة خط الزوال
دائرة مشجّرة/مدرّجة (graduated circle)	دائرة مشجّرة/مدرّجة (graduated circle)

69 motor-driven level, a compensator level	ميزان مسأحي يعمل بمحرك
70 electro-optical distance-measuring instrument	آلة قياس مسافات كهروبصرية
71 stereometric camera	كاميرا مجسّمة
72 horizontal base	قاعدة أفقية
73 one-second theodolite	مزواة/ثيودوليت للقياس في الثانية الواحدة
113 Optical Instruments II	الألات البصريّة (2)
1 2.2 m reflecting telescope (reflector)	تليسكوب 2,2 ملم عاكس
2 pedestal (base)	قاعدة
3 axial-radial bearing	مخمل محوري نصف قطري
4 declination gear	آلية ضبط الميل
5 declination axis	محور الانحراف الزاوي/الميل
6 declination bearing	مخمل آلية ضبط الميل
7 front ring	اللفة الأمامية
8 tube (body tube)	أنبوب
9 tube centre (Am. center) section	جزء مركز الأنبوب
10 primary mirror (main mirror)	المرآة الرئيسية
11 secondary mirror (deviation mirror, corrector plate)	المرآة الثانوية (مرآة الانحراف)
12 fork mounting (fork)	مخمل شوكة
13 cover	غطاء
14 guide bearing	مخمل دليلي
15 main drive unit of the polar axis	وحدة الإدارة الرئيسية للمحور القطبي
16-25 telescope mountings (telescope mounts)	مخامل التليسكوب
16 refractor (refracting telescope) on a German-type mounting	تليسكوب عاكس مثبت على قاعدة من الطراز الألماني
17 declination axis	محور الميل
18 polar axis	المحور القطبي
19 counterweight (counterpoise)	ثقل موازن
20 eyepiece	عينية
21 knee mounting with a bent column	مخمل مرفقي ذو عمود محثي
22 English-type axis mounting (axis mount)	مخمل محوري من الطراز الإنجليزي
23 English-type yoke mounting (yoke mount)	مخمل مقرون من الطراز الإنجليزي
24 fork mounting (fork mount)	مخمل شوكة (مشتعّب)
25 horseshoe mounting (horseshoe mount)	مخمل على شكل حدوة الفرس
26 meridian circle	(جهاز) دائرة خط الزوال
27 divided circle - (graduated circle)	دائرة مشجّرة/مدرّجة (graduated circle)

44 yellow filter adjustment (minus blue filter adjustment)	ذراع ضبط مرشح الصبغ الأصفر
45 cyan filter adjustment (minus red filter adjustment)	ذراع ضبط مرشح لون السيان
46 red swing filter	مرشح الصبغ الأحمر المترجّع
47 print tongs	ملقط مسك الصور المطبوعة
48 processing drum	أسطوانة معالجة
49 squeegee	ممسحة مطاوية
50 range (assortment) of papers	تشكيلة من الأوراق
51 colour (Am. color) printing paper, a packet of photographic printing paper	ورق طباعة الصور الملونة
52 colour (Am. color) chemicals (colour processing chemicals)	مواد كيميائية للطباعة الملونة
53 enlarging meter (enlarging photometer)	مقياس التكبير
54 adjusting knob with paper speed scale	ذراع ضبط مرؤد بمقياس سرعة الورق
55 probe	مستبان
56 semi-automatic thermostatically controlled developing dish	طبق إظهار نصف آلي يتم التحكم فيه ترموستاتياً
57 rapid print drier (heated print drier)	مجفف سريع للصور المطبوعة
58 glazing sheet	فردح تلميع
59 pressure cloth	نسج (قطني) ضاغط
60 automatic processor (machine processor)	ماكينة معالجة آلية
117 Cine Film	التصوير السينمائي
1 cine camera, a Super 8 sound camera	كاميرا سينمائية، كاميرا سوبر 8 صوتية
2 interchangeable zoom lens (variable focus lens, varifocal lens)	عدسة زوم قابلة للإبدال (عدسة متغيرة البؤرة)
3 distance setting (focus setting) and manual focal length setting	ضبط المسافة وضبط الطول البؤري يدوياً
4 aperture ring (aperture-setting ring, aperture control ring) for manual aperture setting	حلقة ضبط فتحة العدسة لضبط الفتحة يدوياً
5 handgrip with battery chamber	مقبض الكاميرا وبه حجرة البطارية
6 shutter release with cable release socket	زر تحرير مغلاق العدسة ومقبض تحرير الكيل
7 pilot tone or pulse generator socket for the sound recording equipment (with the dual film-tape system)	مقبس النغمة الدلالية أو مولد الترددات الخاص ببعثات تسجيل الصوت (في نظام شريط الفيلم الشاشي)
8 sound connecting cord for microphone or	سلك توصيل الصوت الخاص بالميكروفون أو

19 bayonet mounting ring	حلقة توصيل على شكل حربة
20 aperture setting button	زر ضبط فتحة العدسة
21 lens release	زر إطلاق العدسة
22 focus-mode switch (to switch to manual focusing)	مفتاح نمط ضبط البؤرة (للتحويل إلى إحكام البؤرة يدوياً)
23 autofocus zoom lens, a x3 zoom lens (35-105 mm)	عدسة زوم آلية الإحكام البؤري (35-105 مم)
24 aperture and autofocus contacts	ملاصقات فتحة العدسة والبؤرة الآلية
25-35 viewfinder screen (focusing screen, matt screen), a micro-honeycombed focusing screen	شاشة محدّد الرؤية (شاشة الإحكام البؤري)
25 flash-on signal	إشارة تشغيل الفلاش
26 flash-ready signal	إشارة أن الفلاش جاهز للتشغيل
27 focus signals	إشارات التركيز البؤري
28 wide focus area	منطقة واسعة البؤرة
29 shutter speed display	شاشة عرض سرعة مغلاق العدسة
30 manual-exposure compensation-value indicator	مؤشر القيمة الموازنة للتعويض للضوء يدوياً
31 aperture or exposure adjustment indicator	مؤشر ضبط فتحة العدسة أو تعويض الفيلم للضوء
32 spot metering indicator	مؤشر القياس الفوري
33 spot metering area	منطقة القياس الفوري
34 centre focus area	منطقة البؤرة المركزية
35 focus area indicator	مؤشر منطقة البؤرة
36-42 LCD data panel (data monitor)	لوحة البيانات
36 program exposure-mode indicator	مؤشر تعويض الفيلم للضوء
37 frame counter	عداد إطاري
38 function indicators	مؤشرات الوظائف
39 aperture or exposure adjustment indicator	مؤشر ضبط فتحة العدسة أو التعويض للضوء
40 shutter speed or film speed (film sensitivity) indicator	مؤشر سرعة مغلاق العدسة أو سرعة الفيلم
41 film transport indicator	مؤشر لف الفيلم للأمام
42 function pointer	مؤشر الوظيفة
43 interchangeable lenses (autofocus lenses, AF lenses)	عدسات قابلة للإبدال فيما بينها
44 fisheye lens (fisheye)	عدسة عين السمكة
45 wide-angle lens (short focal-length lens)	عدسة واسعة الزاوية (عدسة قصيرة البعد البؤري)
46 standard lens	عدسة قياسية
47 medium focal-length lens	عدسة متوسطة الطول البؤري
48 telephoto lens (long focal-length lens), a zoom lens (variable	عدسة تصوير عن بعد (عدسة طويلة البعد البؤري)، عدسة زوم

focus lens, varifocal lens)	عدسة متنوعة البعد البؤري
49 long-focus lens	عدسة طويلة البعد البؤري
50 mirror lens	عدسة مرآوية
51 tele converter	محول التصوير عن بعد
52 data back	ظهر كتابة البيانات
53 ten-metre (Am. ten-meter) film back (magazine back)	ظهر مخزن فيلم 10م (المخزن)
54-74 accessories for close-up and macro shots	ملحقات تصوير المناظر القريبة واللقطات الكبيرة
54 extension tube	أنبوب استطالة
55 adapter ring	حلقة مهايئة
56 reversing ring	حلقة عاكسة
57 lens in retrofocus position	عدسة في وضع إحكام خلفي
58 bellows unit (extension bellows, close-up bellows attachment)	وحدة منفاخ الكاميرا
59 focusing stage	منصة التركيز البؤري
60 slide-copying attachment	ملحق شريحة نسخ الشرائح
61 slide-copying adapter	مهايئ الشريحة الناسخة
62 cable release	زر تحرير الكيل
63 copying stand (copy stand)	حامل النسخ (حامل النسخة)
64 arm of the copying stand (copy stand)	ذراع حامل النسخة
65 rifle grip	قبضة بندقية
66 table (-top) tripod (mini tripod)	حامل نضدي ثلاثي (حامل صغير)
67 ever-ready case	حقيبة كاميرا مجهزة
68 lens case	غلبة العدسات
69 soft-leather lens pouch	كيس من الجلد الطري لحفظ العدسات
70 camera bag, of metallic construction: aluminium (Am. aluminum) case	حقيبة الكاميرا من المعدن، صندوق من الألومنيوم
71 film container	غلبة الفيلم
72 filter case	غلبة المرشحات
73 second body	الجسم الثاني
74 ring flash for macro shots	فلاش حلقي للفتحات الكبيرة
116 Photography III	التصوير (3)
1-60 darkroom equipment	معدات الحجرة المظلمة
1 developing tank	خزان الإظهار
2 spiral (developing spiral, tank reel)	حلزون (حلزون الإظهار، بكرّة الخزان)
3 multi-unit developing tank	خزان إظهار متعدد الوحدات
4 multi-unit tank spiral	حلزون إظهار متعدد الوحدات
5 daylight-loading tank	خزان تعبئة الأفلام في ضوء النهار
6 loading chamber	حجرة تعبئة الفيلم
7 film transport handle	ذراع تقديم الفيلم
8 developing tank thermometer	ترمومتر خزان الإظهار
9 collapsible bottle for developing solution	قنبلة مطول الإظهار قابلة للطي
10 chemical bottles for first developer, stop bath, colour developer, bleach-hardener, stabilizer	قنبيات تحوي مواد كيميائية للظهور الأول، حمام الإيقاف، مظهر الألوان، ممسك مادة التقصير، والمستحلب
11 measuring cylinders	أسطوانات قياس
12 funnel	قمع
13 tray thermometer (dish thermometer)	ترمومتر صينية
14 film clip	مشبك تثبيت الأفلام
15 wash tank (washer)	خوض غسل
16 water supply pipe	أنبوب إمداد الماء
17 water outlet pipe	أنبوب خروج الماء
18 laboratory timer (timer)	جهاز توقيت مختبري
19 automatic film agitator	مقلب أفلام آلي
20 developing tank	خزان الإظهار
21 darkroom lamp (safe-light)	مصباح الحجرة المظلمة (ضوء آمن)
22 filter screen	ستار ترشيح
23 film drier (drying cabinet)	كابينة تجفيف الأفلام
24 exposure timer	جهاز توقيت ضبط مدة التعريض للضوء صينية الإظهار
25 developing dish (developing tray)	ألة التكبير
26 enlarger	لوح القاعدة
27 baseboard	عمود زاوي
28 angled column	ذروة المصباح
29 lamphouse (lamp housing)	حامل النتاجات
30 negative carrier	مفتاح الكاميرا
31 bellows	عدسة
32 lens	ناقل حركة احتكاكي للضبط الدقيق
33 friction drive for fine adjustment	آلية ضبط الارتفاع
34 height adjustment (scale adjustment)	برواز الطبع التصويري
35 masking frame (easel)	محلّل الألوان
36 colour (Am. color) analyser	مصباح محلّل الألوان
37 colour (Am. color) analyser lamp	سلك مستبان
38 probe lead	زر موازنة فترة التعريض
39 exposure time balancing knob	ألة تكبير بالألوان
40 colour (Am. color) enlarger	رأس ألة التكبير
41 enlarger head	قائم عمودي
42 column	آلية خلط الألوان
43-45 colour-mixing (Am. color-mixing) knob	ذراع ضبط مرشح الماجتا
43 magenta filter adjustment (minus green filter adjustment)	

external sound source (in single-system recording)	مصدر صوت خارجي
9 remote control socket (remote control jack)	مقبس التحكم من بعد (جاك التحكم من بعد)
10 headphone socket (sim.: earphone socket)	مقبس السماعات
11 autofocus override switch	مفتاح تجاوز الضبط الأوتوماتي للبعد البؤري
12 filming speed selector	مفتاح ضبط سرعة التصوير
13 sound recording selector switch for automatic or manual operation	مفتاح اختيار نظام تسجيل الصوت للتشغيل الآلي أو اليدوي
14 eyepiece with eyecup	عدسة الكاميرا وكأس العين
15 diopter control ring (dioptric adjustment ring)	حلقة التحكم في ديوبتر العدسة
16 recording level control (audio level control, recording sensitivity selector)	التحكم في مستوى تسجيل الصوت
17 manual/automatic exposure control switch	مفتاح التحكم الخاص بتعريض الفيلم للضوء يدويًا/آليًا
18 film speed setting	ضبط سرعة الفيلم
19 power zooming arrangement	نظام تشغيل الزوم
20 automatic aperture control	التحكم آلياً في فتحة العدسة
21 sound track system	نظام مسلك الصوت
22 sound camera	كاميرا تسجيل صوت وصورة
23 telescopic microphone boom	ذراع استطلاع ميكروفون تليسكوبي
24 microphone	ميكروفون
25 microphone connecting lead (microphone connecting cord)	سلك توصيل الميكروفون
26 mixing console (mixing desk, mixer)	كوسول المزج
27 inputs from various sound sources	مدخلات من عدة مصادر للصوت
28 output to camera	خارج توصيل بالكاميرا
29 Super-8 sound film cartridge	خراطوش فيلم تسجيل صوتي لكاميرا سوبر 8
30 film gate of the cartridge	بوابة الفيلم بالخراطوش
31 feed spool	بكرة إلقاء الفيلم
32 take-up spool	بكرة التقاط الفيلم
33 recording head (sound head)	رأس التسجيل
34 transport roller (capstan)	أسطوانة لف الفيلم
35 rubber pinch roller (capstan idler)	أسطوانة مطاطية
36 guide step (guide notch)	درجة دليلية
37 exposure meter control step	آلية التحكم في مقياس تعريض الفيلم للضوء

38 conversion filter step (colour, Am. color, conversion filter step)	آلية فلتر التحويل
39 single-8 cassette	كاسيت فيلم كاميرا 8 مفرد المسلك
40 film gate opening	فتحة بوابة الفيلم
41 unexposed film	فيلم لم يُعرض للضوء
42 exposed film	فيلم تم تعريضه للضوء
43 16 mm camera	كاميرا 16 ملم
44 reflex finder (through-the-lens reflex finder)	مُحدّد رؤية انعكاسي
45 magazine	مخزن الفيلم
46-49 lens head	رأس العدسة
46 lens turret (turret head)	برج العدسة
47 telephoto lens	عدسة التصوير من بُعد
48 wide-angle lens	عدسة واسعة الزاوية
49 normal lens (standard lens)	عدسة عادية (عدسة قياسية)
50 winding handle	ذراع لف الفيلم
51 compact Super-8 camera	كاميرا سوبر 8 مدمجة
52 footage counter	عداد اللقطات
53 macro zoom lens	عدسة زوم للتصوير الكبير
54 zooming lever	ذراع تشغيل الزوم
55 macro lens attachment (close-up lens)	عدسة تصوير اللقطات الكبيرة (عدسة تصوير اللقطات القريبة)
56 macro frame (mount for small originals)	إطار تركيب الصور الأصلية الصغيرة المراد تكبيرها
57 underwater housing (underwater case)	غاية الكاميرا للتصوير تحت الماء
58 direct-vision frame finder	مُحدّد إطار الرؤية المباشرة
59 measuring rod	قضيب قياس
60 stabilizing wing	جناح تثبيت
61 grip (handgrip)	مقبض صندوق الكاميرا
62 locking bolt	مسمار ربط
63 control lever (operating lever)	ذراع التشغيل
64 porthole	فتحة صندوق الكاميرا
65 synchronization start (sync start)	بدء التسجيل المتزامن
66 professional press-type camera	كاميرا تصوير صحافي
67 cameraman	المصور
68 camera assistant (sound assistant)	المصور المساعد
69 handclap marking sync start	إشارة يدوية لبدء التصوير المتزامن بالصوت والصورة
70 dual film-tape recording using a tape recorder	التسجيل الثنائي باستخدام مسجل بشريط فيلمي
71 pulse-generating camera	كاميرا توليد نبضي
72 pulse cable	كابل نبضي
73 cassette recorder	جهاز تسجيل كاسيت
74 microphone	ميكروفون
75 dual film-tape reproduction	نسخ شريط تصوير فيلمي ثنائي المسلك

76 tape cassette	كاسيت الشريط
77 synchronization unit	وحدة التزامنة
78 cine projector	بروجكتور عرض سينمائي
79 film feed spool	بكرة إلقاء الفيلم
80 take-up reel (take-up spool), an automatic take-up reel (take-up spool)	بكرة التقاط الفيلم، بكرة آلية للتقاط الفيلم
81 sound projector	بروجكتور صوتي
82 sound film with magnetic stripe (sound track, track)	فيلم صوتي ذو شريط مغناطيسي
83 automatic-threading button	زر الضبط الآلي للصورة
84 trick button	زر ضبط الألوان الثلاثية
85 volume control	زر التحكم في درجة ارتفاع الصوت
86 reset button	زر إعادة ضبط الشريط
87 fast and slow motion switch	مفتاح العرض السريع والبطيء للشريط
88 forward, reverse, and still projection switch	مفتاح تقديم وعكس وتثبيت الفيلم
89 splicer for wet splices	جهاز جندل الشرائط
90 hinged clamping plate	لوحة قامة مفصليّة
91 film viewer (animated viewer editor)	جهاز مشاهدة الفيلم للمونتاج
92 foldaway reel arm	ذراع بكرة فرد الشريط
93 rewind handle (rewinder)	ذراع لف الشريط
94 viewing screen	شاشة المشاهدة
95 film perforator (film marker)	آلية تثقيب الفيلم
96 six-turntable film and sound cutting table (editing table, cutting bench, animated sound editor)	طاولة المونتاج
97 monitor	شاشة متابعة
98 control buttons (control well)	مفاتيح التحكم
99 film turntable	سوّاق الفيلم
100 first sound turntable, e.g. for live sound	سوّاق اسطوانات التسجيل الصوتي الأول، التسجيل الحي مثلا
101 second sound turntable for post-sync sound	سوّاق اسطوانات التسجيل الصوتي الثاني لبدء ضبط التزامنة
102 film and tape synchronizing head	رأس مزامنة الصورة مع الصوت
118 Building Site (Construction Site) I	موقع البناء/الإنشاءات (1)
1-49 carcass (carcass, fabric) [house construction, carcassing]	هيكل إنشاء [هيكل منزل]
1 basement of tamped (rammed) concrete	قاعدة من الخرسانة المدكوكة
2 concrete base course	مدماك القاعدة الخرسانية
3 cellar window (base-	نافذة القبو

ment window)	درجات القبو الخارجية
4 outside cellar steps	نافذة غرفة المنايع
5 utility room window	باب غرفة المنايع
6 utility room door	الطابق الأرضي
7 ground floor (Am. first floor)	حائط من الطوب
8 brick wall	عتبة علوية للنافذة
9 lintel (window head)	الحصيط البنائي حول النافذة
10 reveal	عضادة النافذة
11 jamb	عتبة سفلية للنافذة
12 window ledge (window sill)	عتبة علوية من الخرسانة المسلحة
13 reinforced concrete lintel	الطابق العلوي
14 upper floor (first floor, Am. second floor)	حائط من القوالب المفرّغة
15 hollow-block wall	أرضية خرسانية
16 concrete floor	منصة الشغل
17 work platform (working platform)	البناء
18 bricklayer (Am. brick-mason)	مساعد البناء
19 bricklayer's labourer (Am. laborer); also: builder's labourer	حوض الملائط
20 mortar trough	مدخنة
21 chimney	الوواح غطاء السلم
22 cover (boards) for the staircase	دعامة عمود السقالة
23 scaffold pole (scaffold standard)	درايزين المنصّعة
24 platform railing	كتيبة زاوية في السقالة
25 angle brace (angle tie) in the scaffold	اللوّح المستعرض للسقالة
26 ledger	جسر
27 putlog (putlock)	منصة من الألواح الخشبية
28 plank platform (board platform)	لوّح وقاية
29 guard board	وصلة منضّب السقالة ذات سلسلة أو وطاق أو حبل أو رباط
30 scaffolding joint with chain or lashing or whip or bond	مرفاع إنشاء
31 builder's hoist	عاميل/شغل الخلالط
32 mixer operator	خلاط الخرسانة
33 concrete mixer, a gravity mixer	برميل الخلط
34 mixing drum	قادوس التغذية
35 feeder skip	كثبانة خرسانية (رمل) وحصني
36 concrete aggregate [sand and gravel]	عربة يد ذات دولاب واحد
37 wheelbarrow	خراطوم
38 hose (hosepipe)	حوض الملائط
39 mortar pan (mortar trough, mortar tub)	رصّة من قوالب الطوب
40 stack of bricks	الوواح شدّة خرسانية
41 stacked shutter boards (lining boards)	مرصوعة (الوواح تبطين)
42 ladder	سلم تقال
43 bag of cement	كيس أسمنت

44 site fence, a timber fence	سور الموقع، سور خشبي
45 signboard (billboard)	لافتة
46 removable gate	بوابة قابلة للإزالة
47 contractors' name plates	لوحة أسماء المقاولين
48 site hut (site office)	كنكك الموقع (مكتب الموقع)
49 building site latrine	مرحاض موقع البناء
50-57 bricklayer's (Am. brickmason's) tools	أدوات البنّاء
50 plumb bob (plummet)	خطيط المظمار، الشاقول
51 thick lead pencil	قلم رصاص سميك
52 trowel	مائع، مسطرين
53 bricklayer's (Am. brickmason's) hammer (brick hammer)	مطرقة البنّاء
54 mallet	مطرقة خشبية الرأس
55 spirit level	ميزان تسوية
56 laying-on trowel	مسطرين رص الطوب
57 float	لوح عجين المونة
58-68 masonry bonds	أربطة البنّاء
58 brick (standard brick)	قالب طوب عادي
59 stretching bond	رباط شتاي
60 heading bond	رباط أدبيات
61 racking (raking) back	أدبة مخلوطة
62 English bond	رباط إنجليزي
63 stretching course	مدمّك شتاي
64 heading course	مدمّك أدبيات
65 English cross bond (Saint Andrew's cross bond)	رباط الصليب الإنجليزي
66 chimney bond	رباط المدخنة
67 first course	المدّماك الأول
68 second course	المدّماك الثاني
69-82 excavation	الحفر
69 profile (Am. batter-board) [fixed on edge at the corner]	لوح عرضي [مثبت على حافة بالزاوية]
70 intersection of strings	تقاطع الحبال
71 plumb bob (plummet)	خطيط المظمار، الشاقول
72 excavation side	جانب الحفر
73 upper edge board	لوح الحافة العلوية
74 lower edge board	لوح الحافة السفلية
75 foundation trench	خندق الأساس
76 navy (Am. excavator)	الحفّار
77 conveyor belt (conveyor)	سَيْر ناقل
78 excavated earth	تراب الحفّر
79 plank roadway	طريق معدّب بالألواح الخشبية
80 tree guard	وقاء الشجر
81 mechanical shovel (excavator)	مجرّفة ميكانيكية (حفّارة)
82 shovel bucket (bucket)	قادوس المجرّفة
83-91 plastering	التجصيص، البياض
83 plasterer	جصّاص
84 mortar trough	خوض الملاط
85 screen	غُرْبَال
86-89 ladder scaffold	سقالة سلّمية

86 standard ladder	سلّم عادي
87 boards (planks, platform)	ألواح خشبية
88 diagonal strut (diagonal brace)	رباط/بشكال مائل
89 railing	حاجز، درابزين
90 guard netting	شبكة واقية
91 rope-pulley hoist	مرفاع ذو حبل وبكرة
119 Building Site (Construction Site) II	موقع البناء/الإنشاءات (2)
1-89 reinforced concrete (ferroconcrete) construction	إنشاءات الخرسانة المسلحة
1 reinforced concrete (ferroconcrete) skeleton construction	إنشاء هيكل من الخرسانة المسلحة
2 reinforced concrete (ferroconcrete) frame	إطار من الخرسانة المسلحة
3 inferior purlin	مدّاعة/رافدة (أفقية) سفلية
4 concrete purlin	مدّاعة أفقية خرسانية
5 ceiling joist	حائز السقف
6 arch (flank)	عقد
7 rubble concrete wall	حائط خرسانة نديش
8 reinforced concrete (ferroconcrete) floor	أرضية خرسانية مسلحة
9 concrete (concretor), flattening out	عامل الخرسانة (يقوم بالتسوية)
10 projecting reinforcement (Am. connection rebars)	قضبان تسليح بارزة
11 column box	صندوق العمود
12 joist shuttering	شدة خرسانية ذات روافد
13 shuttering strut	عمود شدة خرسانية
14 diagonal bracing	رباط/بشكال مائل
15 wedge	خابور، إسفين
16 board	عارضة خشبية
17 sheet pile wall (sheet pile, sheet piling)	خوازيق ستارة
18 shutter boards (lining boards)	ألواح شدة خرسانية (الواح تطيين)
19 circular saw (buzz saw)	منشار دائري/قرصي
20 bending table	نضد ثني قضبان المسلح
21 bar bender (steel bender)	عامل ثني المسلح
22 hand steel shears	مقص صلب يدوي
23 reinforcing steel (reinforcement rods)	سبخ تسليح فولاذي
24 pumice concrete hollow block	قوالب مفرّغة من خرسانة الحجر الخفاف
25 partition wall, timber wall	جدار فاصل، جدار خشبي
26 concrete aggregate [gravel and sand of various grades]	كتّالة خرسانية [حصّى ورم ملّتحجّج]
27 crane track	مسار الوشّ
28 tipping wagon (tipping truck)	عربة نقل قلابية

29 concrete mixer	خلّاط الأسمنت
30 cement silo	خزّانة الأسمنت
31 tower crane (tower slewing crane)	مرفّاع بُرجي
32 bogie (Am. truck)	عربة نقل منخفضة
33 counterweight	ثقل موازن
34 tower	بُرج المرفّاع
35 crane driver's cabin (crane driver's cage)	كابينة سائق المرفّاع
36 jib (boom)	ذراع تطويل المرفّاع
37 bearer cable	كبل الحمل
38 concrete bucket	قادوس الخرسانة
39 sleepers (Am. ties)	فلنكات، أربطة
40 chock	إسفين لمنع الانزلاق/ للإيقاف
41 ramp	منحدر
42 wheelbarrow	عربة يد ذات دولاب واحد
43 safety rail	حاجز أمان
44 site hut	كنكك الموقع
45 canteen	الكانتين
46 tubular steel scaffold (scaffolding)	سقالة أنابيب صلب
47 standard	عمود السقالة
48 ledger tube	اللوح المستعرض للسقالة
49 tie tube	أنبوبة ربط/شد
50 shoe	كعب، قاعدة (السقالة)
51 diagonal brace	رباط/بشكال مائل
52 planking (platform)	ألواح خشبية (مبضّة)
53 coupling (coupler)	قارئة، رباط
54-76 formwork (shuttering) and reinforcement	أعمال الشدّة الخرسانية والتسليح
54 bottom shuttering (lining)	الشدّة الخرسانية السفلية (بطانة)
55 side shutter of a purlin	اللوح الجانبي للحائز/ الرافدة
56 cut-in bottom	قاعدة
57 cross beam	كمرّة مستعرضة
58 clamp iron (clamp, dog)	قامطة حديد
59 upright member, a standard	عمود قائم
60 strap	طوق، شبر
61 cross piece	كمرّة مستعرضة
62 stop fillet	عصابة، باكتة تلبّيس
63 strut (brace, angle brace)	رباط، كتف، بشكال
64 frame timber (yoke)	دعامة رابطة (مقرّن)
65 strap	طوق، شبر
66 reinforcement binding	قضيب مسلح رابط
67 cross strut (strut)	رافدة مستعرضة
68 reinforcement	قضيب مسلح
69 distribution steel	قضيب توزيع
70 stirrup	ركاب، طوق
71 projecting reinforcement (Am. connection rebars)	قضبان تسليح بارزة
72 concrete (heavy concrete)	خرسانة (خرسانة ثقيلة)

73 column box	صندوق العمود
74 bolted frame timber (bolted yoke)	دعامة رابطة بالمسامير الملوية
75 nut (thumb nut)	صامولة ربط
76 shutter board (shuttering board)	لوح الشدة الخرسانية
77-89 tools	أدوات
77 bending iron	قضيب الثني
78 adjustable service girder	عارضة خدمة قابلة للضبط
79 adjusting screw	لُؤب الضبط
80 round bar reinforcement	قضيب مسلح دائري المقطع
81 distance piece (separator, spacer)	قطعة مبادعة
82 Torsteel	فولاذ عالي المقاومة
83 concrete tamper	مدّك الخرسانة
84 mould (Am. mold) for concrete test cubes	قالب مكعبات اختبار الخرسانة
85 concrete's tongs	ملقط كلابة عامل الخرسانة
86 sheeting support	حامل الألواح الشدة الخرسانية
87 hand shears	مقص يدوي
88 immersion vibrator (concrete vibrator)	هزازة غاطسة (هزاز الخرسانة)
89 vibrating cylinder (vibrating head, vibrating poker)	أسطوانة هزازة (رأس هزاز)
120 Carpenter	النجّار
1-59 carpenter's yard	ساحة النجارة
1 stack of boards (planks)	رصّة من الألواح الخشبية
2 long timber (Am. lumber)	لوح خشب طويل (عرق خشب)
3 sawing shed	هتجر نشر الخشب
4 carpenter's workshop	متجرّة
5 workshop door	باب المتجرّة
6 handcart	عربة يدوية
7 roof truss	جملون السقف
8 tree [used for topping out ceremony] with wreath	شجرة ذات إكليل
9 timber wall	جدار خشبي
10 squared timber (building timber, scantlings)	خشب مربع المقطع (خشب بناء)
11 drawing floor	أرضية السحب
12 carpenter	النجّار
13 safety helmet	خوذة أمان
14 cross-cut saw, a chain saw	منشار قطع متعاض، منشار بسلسلة
15 chain guide	دليل السلسلة
16 saw chain	سلسلة المنشار
17 mortiser (chain cutter)	أداة نقر/قطع
18 trestle (horse)	مبض (حصان)
19 beam mounted on a trestle	كمرّة عارضة فوق الحصان
20 set of carpenter's tools	طاقم عدّة النجّار
21 electric drill	مقبّاب كهربائي

board)	رَبَاط شَدَاة بسيط
49 simple tie	رَبَاط شَدَاة مَزْذُوج
50 double tie	رَأْفَذَة أَفْقِيَة، مَدَاة
51 purlin	هَيْكَل سَقْف ذُو رَوَاغِد أَفْقِيَة
52 purlin roof structure with queen post	وَقَائِم جَمْلُون مَلَكَة
53 tie beam	عَمْبَة رَابِطَة
54 joist (ceiling joist)	حَائِز (حَائِز السَّقْف)
55 principal rafter	رَأْفَذَة سَقْف مَائِل رَئِيسِيَة
56 common rafter	رَأْفَذَة سَقْف مَائِل عَادِيَة
57 angle brace (angle tie)	رَبَاط/كَتْف زَاوِي
58 brace (strut)	رَبَاط، كَتْف
59 ties	شَدَاةَات، أَرِبِطَة
60 hip (hipped) roof with purlin roof structure	سَقْف مَهْرَم ذُو هَيْكَل بَرَوَاغِد أَفْقِيَة
61 jack rafter	رَأْفَذَة سَقْف مَائِل جَانِبِيَة
62 hip rafter	قَصِيرَة
63 jack rafter	رَأْفَذَة سَقْف مَائِل سَنَامِيَة
64 valley rafter	رَأْفَذَة سَقْف مَائِل جَانِبِيَة
65 queen truss	قَصِيرَة
66 main beam	رَأْفَذَة سَقْف مَائِل رَكْبِيَة/زَاوِيَة
67 summer (summer beam)	قَائِم جَمْلُون مَلَكَة
68 queen post (truss post)	كَمَر رَئِيسِي
69 brace (strut)	عَمْبَة عُلُويَة
70 collar beam (collar)	قَائِم جَمْلُون/رَئِيسِي
71 trimmer (Am. header)	رَبَاط، كَتْف، شَكَاك
72 solid-web girder	عَمْبَة شَدَاةَة (شَدَاة)
73 lower chord	أَدِيَة، حَائِز طُولَايِي خَنِين
74 upper chord	رَأْفَذَة ذَات وَتْرَة مَصْمُتَة
75 boarding	وَتْر سَفْلِي
76 purlin	وَتْر عُلُوي
77 supporting outer wall	لُوح تَغْطِيَة
78 roof truss	رَأْفَذَة أَفْقِيَة
79 lower chord	حَائِظ الإِشْدَاد الخَارِجِي
80 upper chord	جَمْلُون السَّقْف
81 post	وَتْر سَفْلِي
82 brace (strut)	وَتْر عُلُوي
83 support	عَمُود، دِعَامَة
84-88 timber joints	رَبَاط، كَتْف، شَكَاك
84 mortise (mortice) and tenon joint	مَرْتَكز، دِعَامَة، حَامِل
85 forked mortise (mortice) and tenon joint	وَصْلَات خَشْبِيَة
86 halving (halved) joint	وَصْلَة نَقْرَة وِلْسَان
87 simple scarf joint	وَصْلَة تَمْشِيق نَصْف عُلَى
88 oblique scarf joint	نَصْف
89 dovetail halving	وَصْلَة تَرَكَبِيَة بَسِطَة
90 single skew notch	وَصْلَة تَرَكَبِيَة مَائِلَة
91 double skew notch	وَصْلَة نَغْفَارِيَة نَصْفِيَة
92 wooden nail	وَصْلَة ذَات لُتْمَة مَائِلَة
93 pin	وَصْلَة ذَات لُتْمَتَيْن مَائِلَتَيْن
94 clout nail (clout)	خَابُور خَشْبِي
95 wire nail	وَد
96 hardwood wedges	مِسْمَار مَرَبِيع الرَأْس
	مِسْمَار إِبْرَة
	أَسَافِين مِّن الخَشْب الصَلْب

22 dowel hole	ثَقْب الدَّسَار
23 mark for the dowel hole	عِلَامَة مَوْضِع ثَقْب الدَّسَار
24 beams	كَمَر، عَوَارِض خَشْبِيَة
25 post (stile, stud, quarter)	عَمُود، دِعَامَة
26 corner brace	شَدَاة/رَبَاط الرِّكْن
27 brace (strut)	كَتْف/رَبَاط شَدَاة
28 base course (plinth)	مِذْمَاك القَاعَة (بِرْذُورَة)
29 house wall (wall)	جِدَار المَنْزَل، حَائِظ المَنْزَل
30 window opening	فَتْحَة النَافِذَة
31 reveal	المَحِيط البِنَائِي حَوْل النَافِذَة
32 jamb	عِضَادَة
33 window ledge (window sill)	عَمْبَة سَفْلِيَة لِّلنَافِذَة (مُطَف)
34 cornice	كُورْنِيش، إِفْرِيز
35 roundwood (round timber)	لُوح خَشْبِي دَائِرِي المَقْطَع
36 floorboards	أَلْوَاك تَطْبِيق/الأَرْضِيَة
37 hoisting rope	حَبْل الرِّفْع
38 ceiling joist (ceiling beam, main beam)	عِلْفَة/كَمْرَة السَّقْف (كَمْرَة السَّقْف)
39 wall joist	رَأْفَذَة/كَمْر الحَائِظ
40 wall plate	لُوح جِدَارِي
41 trimmer (trimmer joist, Am. header, header joist)	حَائِز طُولِي خَنِين، أَدِيَة
42 dragon beam (dragon piece)	عَمْبَة مَدْرَعَة (قَطْعَة زَاوِيَة)
43 false floor (inserted floor)	أَرْضِيَة زَائِقَة
44 floor filling of breeze, loam, etc.	حَشْو الأَرْضِيَة مِّن العُغْصَار الرُّطْبِي وَخِلَافَة
45 fillet (cleat)	شَرِيحَة خَشْبِيَة (قَبِيقَاب سَائِد)
46 stair well (well)	بِئْر السَّلْم
47 chimney	مَدخَة
48 framed partition (framed wall)	فَاصِل/جِدَار جِدَار إِطَارِي
49 wall plate	لُوح جِدَارِي
50 girt	عَارِضَة صَغِيرَة
51 window jamb, a jamb	عِضَادَة نَافِذَة
52 corner stile (corner strut, corner stud)	دِعَامَة المَرَكْن، عَمُود المَرَكْن
53 principal post	الدِعَامَة الرَّئِيسِيَة، العَمُود الرَّئِيسِي
54 brace (strut) with skew notch	رَبَاط/كَتْف ذُو نَقْرَة مَائِلَة
55 nogging piece	عَارِضَة/قَطْعَة تَثْبِيت
56 sill rail	قَضِيب عَمْبَة النَافِذَة
57 window lintel (window head)	العَمْبَة العُلُويَة لِّلنَافِذَة
58 head (head rail)	رَأْس (قَضِيب عُلُوي)
59 filled-in panel (bay, pan)	رَقْعَة الحَائِظ (فَسْحَة بَيْن عَمُودَيْن)
60-82 carpenter's tools	أَدَوَات النَجَّار
60 hand saw	مِشْطَار يَدَوِي
61 bucksaw	مِشْطَار قُوس/عَادِي
62 saw blade	سَلَاح المِشْطَار
63 compass saw (keyhole)	مِشْطَار مَنخَبَات

6 dormer window (dormer)	شَبَاك رُوش (شَبَاك سَقْف جَمْلُونِي)
7 pent roof (shed roof, lean-to roof)	سَقْف مَبْنِي جَانِبِي مَائِل
8 skylight	مَهْرَم
9 fire gable	جَمْلُون جِرَارِي
10 hip (hipped) roof	سَقْف مَسْتَم/مَهْرَم
11 hip end	طَرَف التَهْرِيم/التَضْمِين
12 hip (arris)	حَرْف حَاد (السَّقْف)
13 hip (hipped) dormer window	شَبَاك رُوش مَهْرَم
14 ridge turret	بُرْج سَرَجِي السَّقْف
15 valley (roof valley)	زَاوِيَة قَابِل مَسْتَقِيم مَائِلَيْن
16 hipped-gable roof (jerkin head roof)	سَقْف مَسْتَم مَوْشُورِي
17 partial-hip (partial-hipped) end	طَرَف مَسْتَم جَزْئِيَا
18 mansard roof (Am. gambrel roof)	سَقْف سَدْذِي مَزْذُوج الخَدْر
19 mansard dormer window	نَافِذَة رُوش فِي سَقْف سَدْذِي
20 sawtooth roof	سَقْف أَشْرِي/سِن مِشْطَار
21 north light	وَاجِهَة بَحْرِيَة
22 broach roof	سَقْف مَخْرُزِي/بُرُوش
23 eyebrow	فَلْجَة حَاجِبِيَة
24 conical broach roof	سَقْف مَخْرُزِي مَعْمِي
25 imperial dome (imperial roof)	قَبَة إِمْبِرَاطُورِيَة
26 weather vane	دَوَارَة الرِّيح
27-83 roof structures of timber	هِيََاكَل السَّقْف الخَشْبِيَة
27 rafter roof	سَقْف الرَأْفَذَة
28 rafter	رَأْفَذَة (سَقْف مَائِل)
29 roof beam	كَمْرَة السَّقْف
30 diagonal tie (cross tie, sprocket piece, cocking piece)	رَبَاط شَدَاة مَائِل
31 arris fillet (tilting fillet)	شَدَاة سُوْكَة (شَرْحَة قَلَابَة)
32 outer wall	سَطْح خَارِجِي
33 beam head	رَأْس الكَمْرَة/العَمْبَة
34 collar beam roof (trussed rafter roof)	سَقْف بَعْتَب شَدَاة
35 collar beam (collar)	عَمْب شَدَاة (شَدَاة)
36 rafter	رَأْفَذَة (السَقْف مَائِل)
37 strutted collar beam roof structure	هَيْكَل سَقْف شَدَاة وَقَوَائِم انضِغَاط
38 collar beams	عَمْب شَدَاة، شَدَاةَات
39 purlin	رَأْفَذَة أَفْقِيَة، مَدَاة
40 post (stile, stud)	قَائِم
41 brace	رَبَاط، كَتْف، شَكَاك
42 unstrutted (king pin) roof structure	هَيْكَل سَقْف بِقَائِم جَمْلُون
43 ridge purlin	مَلِك/بَعْض جَمْلُونِي رَئِيسِي
44 inferior purlin	رَأْفَذَة أَفْقِيَة حَرْفِيَة
45 rafter head (rafter end)	رَأْفَذَة أَفْقِيَة سَفْلِيَة
46 purlin roof with queen post and pointing sill	طَرَف رَأْفَذَة السَّقْف المَائِل
47 pointing sill	سَقْف ذُو رَأْفَذَة أَفْقِيَة
48 ridge beam (ridge)	وَجْمَلُون مَلَكَة وَعَمْبَة سَمْنَة عَمْبَة سَمْنَة
	كَمَر حَرْفِي

97	cramp iron (timber dog, dog)	قائمة حديدية (كَلَابِيَة)
98	bolt	مِسْمَار قلاووظ (مُؤَلَّاب)
122 Roof and Roofer	السَّقْف وأجزاء السَّقْف	
1	1 tiled roof	سَقْف قَرَمِيدِي
2	2 plain-tile double-lap roofing	تسقيف مزدوج ببلاط عادي
3	3 ridge tile	قَرَمِيدَة حَرْفِيَة
4	4 ridge course tile	قَرَمِيدَة مدماك حَرْفِيَة
5	5 under-ridge tile	بلاط حَرْفِي
6	6 plain (plane) tile	بلاط سادة (غير منقوشة)
7	7 ventilating tile	بلاط تهوية
8	8 ridge tile	قَرَمِيد حَرْفِي
9	9 hip tile	بلاط تَسْتَمِد / تَهْرِيم
10	10 hipped end	طَرَف مَسْتَم / مَهْرَم
11	11 valley (roof valley)	زَاوِيَة تقابل سَقْفَيْن مائلين
12	12 skylight	مَنَوْر
13	13 chimney	مدخنة
14	14 chimney flashing, made of sheet zinc	حَسْوَة واقية بالمبيخنة من صفائح الزنك لمنع التسرب
15	15 ladder hook	خَطَاف السَلَم
16	16 snow guard bracket	كثيفة واقية الثلوج
17	17 battens (slating and tiling battens)	مُورِينات
18	18 batten gauge (Am. gage)	مقياس المسافات بين الألواح
19	19 rafter	رَافِدَة (السَّقْف مائل)
20	20 tile hammer	مطرقة بلاط
21	21 lath axe (Am. ax)	بُلمة اللَوِيحَات الخشبية
22	22 hod	حَوْض نقل الطوب والملاط
23	23 hod hook	خَطَاف تثبيت الحَوْض
24	24 opening (hatch)	فتحة في السَّقْف
25	25 gable (gable end)	مَقْص جَمَلُون
26	26 toothed lath	لَوْح خشبي مسنن
27	27 soffit	بطنية السَّقْف
28	28 gutter	مِرْزَاب
29	29 rainwater pipe (down-pipe)	ماسورة تصريف ماء المطر
30	30 swan's neck (swan-neck)	عنق إوزي
31	31 pipe clip	مشبك تثبيت ماسورة
32	32 gutter bracket	كثيفة المِرْزَاب
33	33 tile cutter	آلة قطع البلاط
34	34 scaffold	سقالة
35	35 safety wall	جدار أمان
36	36 eaves	أفريز
37	37 outer wall	جدار خارجي
38	38 exterior rendering	تجصيص خارجي
39	39 frost-resistant brick-work	بناء طوب مقاوم للصقيع
40	40 inferior purlin	رَافِدَة أفقية سفلية
41	41 rafter head (rafter end)	طَرَف رَافِدَة (لسَقْف مائل)
42	42 eaves fascia	واجهة الأفريز
43	43 double lath (tilting lath)	قَدَة مزدوجة (قَدَة قلابية)
44	44 insulating boards	ألواح عازلة
45-60	45-60 tiles and tile roofings	المقرميدة/البلاط والأسقف المقرميدة
45	45 split-tiled roof	سَقْف مُنطَلق ببلاط منطوّر

46	46 plain (plane) tile	بلاطة عادية
47	47 ridge course	مِمْسَاك حَرْفِي / ظَهْرِي
48	48 slip	شَرْحَة مبيبة للتسيير
49	49 eaves course	مِمْسَاك الأفريز
50	50 plain-tiled roof	سَقْف من البلاط العادي
51	51 nib	طَرَف بلاطة مُسَنَّ
52	52 ridge tile	قَرَمِيدَة حَرْفِيَة / ظَهْرِيَة
53	53 pantiled roof	سَقْف قَرَمِيدَة مَمُوج متراكب
54	54 pantile	قَرَمِيدَة مَمُوجَة مَتْرَاكِيَة
55	55 pointing	تجميل البلاطات بالملاط أو العونة
56	56 Spanish-tiled roof (Am. mission-tiled roof)	سَقْف من البلاط الأسباني
57	57 under tile	بلاط تحتاني
58	58 over tile	بلاط فَوْقِي
59	59 interlocking tile	بلاط تمتصق
60	60 flat interlocking tile	بلاط تصميق مسطح
61-89	61-89 slate roof	السَّقْف الإردوازي
61	61 roof boards (roof boarding, roof sheathing)	ألواح السَّقْف الخشبية
62	62 roofing paper (sheathing paper); also: roofing felt (Am. rag felt)	وَرَق تسقيف للغزل، أيضا لباد السَّقْف
63	63 cat ladder (roof ladder)	سَلَم السَّقْف
64	64 coupling hook	عقافة، خَطَاف توصيل
65	65 ridge hook	خَطَاف الحافة/الظهر
66	66 roof trestle	مِمْسَب السَّقْف
67	67 trestle rope	حبل المِمْسَب
68	68 knot	عَقْدَة
69	69 ladder hook	خَطَاف السَلَم
70	70 scaffold board	لَوْح السقالة
71	71 slater	عامل تبليط
72	72 nail bag	حقيبة المسامير
73	73 slate hammer	مطرقة الإردواز
74	74 slate nail, a galvanized wire nail	مِسْمَار إردواز، مِسْمَار إبرة مُجَلْفَن
75	75 slater's shoe, a bast or hemp shoe	حذاء عامل التبليط، حذاء لِحائِي أو من القَب
76	76 eaves course (eaves joint)	مِمْسَاك الأفريز
77	77 corner bottom slate	إردواز الركن السفلي
78	78 roof course	مِمْسَاك السَّقْف
79	79 ridge course (ridge joint)	مِمْسَاك حَرْفِي
80	80 gable slate	إردواز الجَمَلُون
81	81 tail line	طَرَف سفلي
82	82 valley (roof valley)	مَفْرَج السقف
83	83 box gutter (trough gutter, parallel gutter)	مِرْزَاب صندوقي
84	84 slater's iron	حديدة عامل التبليط
85	85 slate	خَجِر إردواز
86	86 back	الظهر
87	87 head	الرأس
88	88 front edge	الحافة الأمامية
89	89 tail	الذيل
90-103	90-103 asphalt-impregnated paper roofing and	تسقيف بالورق المُشْبَع بالأسفلت والتسقيف المَمُوج بالأسفلت

corrugated asbestos cement roofing	الأميني	
90	90 asphalt-impregnated paper roof	سَقْف من الوَرَق المُشْبَع بالأسفلت
91	91 width [parallel to the gutter]	عرض [بمُوازاة المِرْزَاب]
92	92 gutter	مِرْزَاب
93	93 ridge	حرف/ظهر السَّقْف
94	94 join	موضع تلاقي لَوْحِين
95	95 width [at right angles to the gutter]	عرض [بزوَايا قائمة من المِرْزَاب]
96	96 felt nail (clout nail)	مِسْمَار ليادي
97	97 corrugated asbestos cement roof	سَقْف مَمُوج من الأسفلت الأميني
98	98 corrugated sheet	لَوْح مَمُوج
99	99 ridge capping piece	قطعة تغطية حَرْف السَّقْف
100	100 lap	طية تراكب
101	101 wood screw	مِسْمَار بريبي للخشب
102	102 rust-proof zinc cup	كأس زنك مقاوم للصدأ
103	103 lead washer	صامولة من الزنك للصلص
123 Floor, Ceiling, Staircase Construction	الأرضية والسَّقْف وإنشاءات السلالم	
1	1 basement wall, a concrete wall	حائط الأساس، جدار خرساني
2	2 footing (foundation)	أساس (قاعدة)
3	3 foundation base	قاعدة الأساس
4	4 damp course (damp-proof course)	طَبَقَة صامدة للرطوبة
5	5 waterproofing	طَبَقَة صامدة للماء
6	6 rendering coat	طَبَقَة تجصيص
7	7 brick paving	تبليط بالطوب
8	8 sand bed	فُرْشَة رملية
9	9 ground	طَبَقَة أساسية
10	10 shuttering	شَدَة الخرسانة
11	11 peg	وتد خابوري
12	12 hardcore	فُرْشَة صلدة
13	13 oversite concrete	خرسانة قاعدية
14	14 cement screed	طَبَقَة علوية أسمنتية للتسوية
15	15 brickwork base	بناء قاعدي من الطوب
16	16 basement stairs, solid concrete stairs	دَرَجَات الطابق الأول
17	17 block step	قالب دَرَجَة السَلَم
18	18 curtain step (bottom step)	دَرَجَة السَلَم السفلية
19	19 top step	دَرَجَة السَلَم العلوية
20	20 nosing	بروز الأنف
21	21 skirting (skirting board, Am. mopboard, wash-board, scrub board, base)	إزار الحائط
22	22 balustrade of metal bars	درايزين بيزمق من القضبان الصلبة
23	23 ground-floor (Am. first-floor) landing	صَدَفَة الطابق الأرضي
24	24 front door	الباب الأمامي
25	25 foot scraper	مَسْحَة الأرجل
26	26 flagstone paving	تبليط بالحجارة الصخرية

27	27 mortar bed	فُرْشَة مَلَاطِيَة
28	28 concrete ceiling, a reinforced concrete slab	سَقْف خرساني
29	29 ground-floor (Am. first-floor) brick wall	جدار الطابق الأرضي
30	30 ramp	المصنوع من الطوب
31	31 wedge-shaped step	مُخَدَّر
32	32 tread	طَبَقَة إسفينية الشكل
33	33 riser	ثامنة الدَرَجَة
34-41	34-41 landing	قائمة الدَرَجَة
34	34 landing beam	صَدَفَة السلالم
35	35 ribbed reinforced concrete floor	عَنْبَة الصَدَفَة
36	36 rib	أرضية مُضَلَعَة من الخرسانة المُسَلَّحَة
37	37 steel-bar reinforcement	ضلع
38	38 subfloor (blind floor)	تجصيب مسلح من الصلب
39	39 level layer	أرضية تحتانية
40	40 finishing layer	طَبَقَة شُويَة
41	41 top layer (screed)	طَبَقَة تططيب
42-44	42-44 dog-legged staircase, a staircase without a well	طَبَقَة علوية
42	42 curtain step (bottom step)	سلالم ملفتوية، سلالم بدون بئر
43	43 newel post (newel)	الدَرَجَة السفلية
44	44 outer string (Am. outer stringer)	قائم الدرابزين
45	45 wall string (Am. wall stringer)	ركيزة خارجية
46	46 staircase bolt	ركيزة جدارية
47	47 tread	مِسْمَار الدَرَج
48	48 riser	ثامنة الدَرَجَة
49	49 wreath piece (wreathed string)	قائمة الدَرَجَة
50	50 balustrade	سَلَم ذو قلابات دائرية
51	51 baluster	درايزين بيزمق
52-62	52-62 intermediate landing	بَرْمَق
52	52 wreath	صَدَفَة سلالم متوسطة
53	53 handrail (guard rail)	إكليل الدرابزين
54	54 head post	درايزين الدَرَج
55	55 landing beam	القائم الرئيسي
56	56 lining board	عَنْبَة الصَدَفَة
57	57 fillet	لَوْح تبطين
58	58 lightweight building board	شَرْحَة خشبية
59	59 ceiling plaster	لَوْح بناء خفيف الوزن
60	60 wall plaster	جِص السَّقْف
61	61 false ceiling	جِص الحائط
62	62 strip flooring (overlay flooring, parquet strip)	سَقْف ظاهري غير حامل
63	63 skirting board (Am. mopboard, washboard, scrub board, base)	أرضية من الألواح الخشبية، أرضية باركيه
64	64 beading	لَوْح إزار الحائط
65	65 staircase window	حُرْ إبطاري
66	66 main landing beam	ثامنة الصَدَفَة السَلَم
67	67 fillet (cleat)	عَنْبَة الصَدَفَة الرئيسية
68-69	68-69 false ceiling	قَبْطَاب ساند
		سَقْف ظاهري غير حامل

68 false floor (inserted floor)	أرضية زائفة
69 floor filling (plugging, pug)	حشو الأرضية
70 laths	قذات خشبية
71 lathing	تبطين خشبي
72 ceiling plaster	جص السقف
73 subfloor (blind floor)	أرضية تضافية
74 parquet floor with tongued-and-grooved blocks	أرضية باركيه من قوالب بحزوز والسنة
75 quarter-newelled (Am. quarter-neweled) staircase	سلم ذو قائم درابزين ربع دائري
76 winding staircase (spiral staircase) with open newels (open-newel staircase)	سلم حلزوني ذو قائم درجي مفتوح
77 winding staircase (spiral staircase) with solid newels (solid-newel staircase)	سلم حلزوني ذو قائم درابزين مضمّت
78 newel (solid newel)	قائم درابزين قائم درابزين مضمّت
79 handrail	درابزين الدراج
124 Glazier	الرّجّاج
1 glazier's workshop	ورشة الرّجّاج
2 frame wood samples (frame samples)	عينات خشب البراويين (عينات براويين)
3 frame wood	خشب براويين
4 mitre joint (mitre, Am. miter joint, miter)	وصلة منطوية زاوية
5 sheet glass; kinds: window glass, frosted glass, patterned glass, crystal plate glass, thick glass, milk glass, laminated glass (safety glass, shatterproof glass)	رّجّاج صفّحي: أنواعه رّجّاج نوافذ، رّجّاج مصغّر، رّجّاج مقوالب رّجّاج، بلوري، رّجّاج سبيك، رّجّاج لبني، رّجّاج رقائق (رّجّاج أمان)
6 cast glass; kinds: stained glass, ornamental glass, raw glass, bull's-eye glass, wired glass, line glass (lined glass)	رّجّاج مصبوب: أنواعه رّجّاج ملون، رّجّاج مزخرف، رّجّاج خام، رّجّاج عين الثور، رّجّاج سبكي، رّجّاج مخطّط
7 mitring (Am. mitering) machine	ماكينة شطب الرّجّاج
8 glassworker (e.g. building glazier, glazier, decorative glass worker)	عامل ورشة الرّجّاج (رّجّاج مباني، رّجّاج، عامل الزخرفة بالرّجّاج)
9 glass holder	حامل أنواع الرّجّاج
10 piece of broken glass	قطعة رّجّاج مكسور
11 lead hammer	مطرقة ذات رأس رصاص
12 lead knife	سكين ذات نصل من الرصاص
13 came (lead came)	كامة من الرصاص
14 leaded light	نافذة ذات إطار معدني من الرصاص

15 workbench	طاولة الشغل
16 pane of glass	لوح زجاجي
17 putty	معجون
18 glazier's hammer	مطرقة الرّجّاج
19 glass pliers	زردية رّجّاج
20 glazier's square	زاوية الرّجّاج
21 glazier's rule	مسطرة الرّجّاج
22 glazier's beam compass	فرجار ذو عاتق
23 eyelet	عروة
24 glazing sprig	مسار الرّجّاج
25-26 glass cutters	قواطع الرّجّاج
25 diamond glass cutter	قاطع ماسي
26 steel-wheel (steel) glass cutter	قاطع ذو دولاب فولادي
27 putty knife	سكين المعجون
28 pin wire	سلك إبرة
29 panel pin	مسار الواح
30 mitre (Am. miter) block (mitre box) [with saw]	قالب القطع المائل / الشطب [مع المشطار]
31 mitre (Am. miter) shoot (mitre board)	لوح مشطوب

125 Plumber	اليسبّاك
1 metal shears (tinner's snips, Am. tinner's shears)	مقص الصفيح
2 elbow snips (angle shears)	قراضة زاوية
3 gib	صفحة معدنية للتثبيت
4 lapping plate	لوح تجليخ بالتحضين
5-7 propane soldering apparatus	جهاز اللحام بالبروبيين
5 propane soldering iron, a hatchet iron	مكواة اللحام بالبروبيين
6 soldering stone, a sal-ammoniac block	حجر اللحام
7 soldering fluid (flux)	صهور لحام
8 beading iron for forming reinforcement beading	أداة تحزيز لتشكل حزوز تقوية
9 angled reamer	مسحل/ مقوار زاوي
10 workbench (bench)	طاولة الشغل
11 beam compass (trammel, Am. beam trammel)	فرجار ذو عاتق (فرجار القطع الناقص)
12 electric hand die	لقمة توليية يدوية كهربائية
13 hollow punch	سنيك أجوف
14 chamfering hammer	مطرقة شدف/ شطب
15 beading swage (beading hammer)	مطرقة تحزيز
16 abrasive-wheel cutting-off machine	ماكينة قص ذات عجلة تجليخ
17 plumber	يسبّاك
18 mallet	مطرقة خشبية
19 mandrel	ماسك العدة، شياق
20 socket (tinner's socket)	جنية
21 block	كتلة القاعدة
22 anvil	سدّان
23 stake	وند

24 circular saw (buzz saw)	مشّار دائري/ قرصي (مشّار أزان)
25 flanging, swaging, and wiring machine	ماكينة حف وتشكيل بالطرق وتقوية بالأسلاك
26 sheet shears (guillotine)	مقص الصفائح المعدنية
27 screw-cutting machine (thread-cutting machine, die stocks)	ماكينة قطع التواليب
28 pipe-bending machine (bending machine, pipe bender)	ماكينة ثني المواسير
29 welding transformer	محوّل اللحام
30 bending machine (rounding machine) for shaping funnels	ماكينة ثني لتشكيل الأقماع

126 Plumber, Gas Fitter, Heating Engineer	المسبّاك، عامل تركيب أجهزة الغاز، مهنيّ السخانات
1 gas fitter and plumber	عامل تركيب أجهزة الغاز والسيّك
2 stepladder	سلم درجي
3 safety chain	سلسلة أمان
4 stop valve	محبس
5 gas meter	عداد الغاز
6 bracket	كتيفة
7 service riser	أنبوب الخدمة
8 distributing pipe	أنبوب/ ماسورة التوزيع
9 supply pipe	أنبوب الإمداد
10 pipe-cutting machine	ماكينة قطع المواسير
11 pipe repair stand	حامل إصلاح المواسير
12-25 gas and water appliances	الأجهزة الكهربائية الخاصة بالغاز والماء
12, 13 geyser an instantaneous water heater	سخان مياه فوري
12 gas water heater	سخان ماء يعمل بالغاز
13 electric water heater	سخان ماء يعمل بالكهرباء
14 toilet cistern	صندوق الطرد (السيفون)
15 float	عوامة
16 bell	جرس
17 flush pipe	ماسورة اندفاع الماء
18 water inlet	دراع تشغيل صندوق الطرد
19 flushing lever (lever)	الضّيق، رديانير
20 radiator	ضلع المشع
21 radiator rib	نظام ذو أنبوبتين
22 two-pipe system	أنبوب الدفق
23 flow pipe	أنبوب استرجاع
24 return pipe	سخان يعمل بالغاز
25 gas heater	تجهيزات السبّابة
26-37 plumbing fixtures	مصنّدة
26 trap (anti-siphon trap)	صنوبر خلاط لأحواض
27 mixer tap (Am. mixing faucet) for washbasins	الفسيل
28 hot tap	صنوبر الماء الساخن
29 cold tap	صنوبر الماء البارد
30 extendible shower attachment	دراع دش قابل للإطالة
31 water tap (pillar tap) for washbasins	صنوبر ماء

32 spindle top	رأس دوراني
33 shield	غلاف واق
34 draw-off tap (Am. faucet)	حنيّة تغريغ
35 supatap	حنيّة
36 swivel tap	حنيّة دوّارة
37 flushing valve	صمام الدفق
38-52 fittings	التركيبات
38 joint with male thread	وصلة ذات لولب خارجي
39 reducing socket (reducing coupler)	قارنة لولبية مصغرة
40 elbow screw joint (elbow coupling)	قارنة مرفقية
41 reducing socket (reducing coupler) with female thread	قارنة مصغرة ذات لولب داخلي
42 screw joint	وصلة لولبية
43 coupler (socket)	قارنة
44 T-joint (T-junction joint, tee)	وصلة ثائية
45 elbow screw joint with female thread	وصلة لولبية مرفقية ذات لولب داخلي
46 bend	كوع منحنى
47 T-joint (T-junction joint, tee) with female taper thread	وصلة ثائية ذات لولب داخلي مخروطي
48 ceiling joint	وصلة شطّية
49 reducing elbow	مرفق مصغّر
50 cross	وصلة تصالبيه
51 elbow joint with male thread	وصلة مرفقية ذات لولب خارجي
52 elbow joint	وصلة مرفقية
53-57 pipe supports	أجزاء تثبيت الأنابيب
53 saddle clip	مشبك سرّجي
54 spacing bracket	كتيفة مبادعة
55 spacer	خابور
56 pipe clips	مشابك أنابيب
57 two-piece spacing clip	مشبك مبادعة من قطعتين
58-86 plumber's tools, gas fitter's tools	أدوات اليسبّاك، أدوات عامل تركيب أجهزة الغاز
58 gas pliers	زردية مواسير الغاز
59 alligator wrench	مفتاح ربط تمساحي
60 combination cutting pliers	قراضة، زردية
61 water pump pliers	زردية فك وربط المواسير
62 flat-nose pliers	زردية مسطحة الطرف
63 nipple key	مفتاح حلّمي
64 round-nose pliers	زردية مستديرة الطرف
65 pinchers	كناشة
66 adjustable S-wrench	مفتاح ستلون قابل للتعديل
67 screw wrench	مفتاح إنجليزي
68 shifting spanner	مفتاح ربط انضباطي
69 screwdriver	مفك
70 compass saw (keyhole saw)	منشار منحنيات
71 hacksaw frame	إطار منشار المعادن
72 hand saw	منشار يدوي
73 soldering iron	مكواة لحام
74 blowlamp (blowtorch)	بورّي لحام

تركيب ورق الحائط

18-53 wallpapering

- (paper hanging)
18 wallpaper (*kinds*: wood pulp paper, wood chip paper, fabric wall-hangings, synthetic wallpaper, metallic paper, natural (e.g. wood or cork) paper, tapestry wallpaper)
19 length of wallpaper
20 burred paper edges
21 matching edge
22 non-matching edge
23 wallpaper paste
24 heavy-duty paste
25 pasting machine
26 paste [for the pasting machine]
27 paste brush
28 emulsion paste
29 picture rail
30 beading pins
31 pasteboard (paper-hanger's bench)
32 gloss finish
33 paperhanging kit
34 shears (bull-nosed scissors)
35 filling knife
36 seam roller
37 hacking knife
38 knife (trimming knife)
39 straightedge
40 paperhanging brush
41 wallpaper-cutting board
42 cutter
43 trimmer
44 plastic spatula
45 chalked string
46 spreader
47 paper roller
48 flannel cloth
49 dry brush
50 ceiling paperhanger
51 overlap angle
52 paperhanger's trestles
53 ceiling paper
- ورق حائط: أنواعه. ورق من لباب الخشب، ورق من نحاتة الخشب، ورق نسيجي، ورق من الألياف الصناعية. ورق معدني. ورق طبيعي (خشب أو فلين أو كئفاه)
 طول ورق الحائط
 أطراف ورق ملصقة تناكبيا
 طرف متطابق (مع الطرف الآخر)
 طرف غير متطابق
 معجون لصق ورق الحائط
 معجون شديد التحمل
 ماكينة المعجنة
 معجون [لماكينة المعجنة]
 فرشاة المعجون
 معجون استحلابي
 إفريز الصورة
 مسامير زخرفية
 طاولة ذهن الورق
 بالمعجون
 طلاء تلميع للتشطيب
 حقيبة أدوات تركيب ورق الحائط
 مقص
 سكين معجون الخشو
 رول تسوية
 سكين تخشين السطح
 سكين (تشديب)
 مسطرة قويمية لاختبار الاستقامة
 فرشاة تركيب ورق الحائط
 لوح تقطيع ورق الحائط
 أداة قطع
 أداة تشذيب
 جاروف بلاستيكي
 خيط طباشيري
 أداة الفرش والتوزيع
 رول الورق
 قماش (قطن)
 فرشاة جافة
 أداة تركيب ورق السقف
 زاوية متداخلة
 سلم تركيب ورق الحائط
 ورق السقف

الصبّاغ، النقّاش

- الصبّاغ، النقّاش
 البهتان، الطلاء
 نقاش. دهان
 فرشاة الدهان
 دهان استحلابي

129 Painter

- 1 painting
 2 painter
 3 paintbrush
 4 emulsion paint (emulsion)

للصدمات

helmet

- 49** tool case
50 cutting nose pliers
51 cutting pliers
52 junior hacksaw
53 combination cutting pliers
54 insulated handle
55 continuity tester
56 electric light bulb (general service lamp, filament lamp)
57 glass bulb (bulb)
58 coiled-coil filament
59 screw base
60 lampholder
61 fluorescent tube
62 bracket for fluorescent tubes
63 electrician's knife
64 wire strippers
65 bayonet fitting
66 three-pin socket with switch
67 three-pin plug
68 fuse carrier with fuse wire
69 light bulb with bayonet fitting

- صندوق العدة
 زردية ذات طرف مستدير
 قرأضة
 ميثار (معدن) صغير
 زردية قطع، قرأضة
 مقبض معزول
 جهاز اختبار استمرار الدائرة الكهربائية
 مصباح كهربى (مصباح بغتيلة)
 بصيلة المصباح الكهربى
 فتيلة ملطوفة (ملطية)
 قاعدة اللؤلؤية
 دوة المصباح
 مصباح فلورى
 كعب تثبيت المصابيح الفلورية
 سكين الكهربائي
 زردية تعرية الأسلاك
 دوة مصباح بمسمارين
 مقبس ثلاثة تقوب مزود بمفتاح كهربى
 قابس ثلاثى السامير
 حامل فيوز مزود بسلك فيوزى
 مصباح كهربى ذو وصلة مسندة (بمسمارين)

128 Paperhanger

1-17 preparation of surfaces

- 1 wallpaper-stripping liquid (stripper)
 2 plaster (plaster of Paris)
 3 filler
 4 glue size (size)
 5 lining paper, a backing paper
 6 primer
 7 fluate
 8 shredded lining paper
 9 wallpaper-stripping machine (stripper)
 10 scraper
 11 smoother
 12 perforator
 13 sandpaper block
 14 sandpaper
 15 stripping knife
 16 masking tape
 17 strip of sheet metal [on which wallpaper is laid for cutting]

- عامل تركيب ورق الحائط
 إعداد الأسطح
 سائل نزع ورق الحائط
 لصوق (جيبس باريس)
 حشو
 غراء
 ورق تبطين، ورق قويمية
 بطانة، طلاء الطبقة الأساسية
 مادة للتصميد للماء
 ورق تبطين مقطع
 ماكينة نزع ورق الحائط
 مكشطة يدوية
 مملسة
 خزامة، أداة تخريم الورق
 كتلة ورق السنفرة
 ورق سنفرة
 سكين تقشير
 شريط تغطية
 لوح معدني صفائحي [يوضع عليه الورق لقطعه]

[لضبط وهج المصباح]

- smooth adjustment of lamp brightness]
18 drill-cast rotary switch
19 miniature circuit breaker (screw-in circuit breaker, fuse)
20 resetting button
21 set screw [for fuses and miniature circuit breakers]
22 underfloor mounting (underfloor sockets)
23 hinged floor socket for power lines and communication lines
24 sunken floor socket with hinged lid (snap lid)
25 surface-mounted socket outlet (plug point) box
26 pocket torch, torch (Am. flashlight)
27 dry cell battery
28 contact spring
29 strip of thermoplastic connectors
30 steel draw-in wire (draw wire) with threading key, and ring attached
31 electricity meter cupboard
32 electricity meter
33 miniature circuit breakers (miniature circuit breaker consumer unit)
34 insulating tape (Am. friction tape)
35 fuse holder
36 circuit breaker (fuse), a fuse cartridge with fusible element
37 colour (Am. color) indicator [showing current rating]
38-39 contact maker
40 cable clip
41 universal test meter (multiple meter for measuring current and voltage)
42 thermoplastic moisture-proof cable
43 copper conductor
44 three-core cable
45 electric soldering iron
46 screwdriver
47 water pump pliers
48 shock-resisting safety

- مفتاح دوار مصبوب قاطع تيار صغير (فيوز)
 زر الضبط
 لولب ضبط [للفيوزات وقواطع التيار الصغيرة]
 تركيب المقابس تحت الأرضية
 مقبس أرضى مفصلي لخطوط الكهرباء والاتصالات
 مقبس أرضى غاطس ذو غطاء مفصلي
 علبه مخرج المقبس من النوع المثبت على الجدار مصباح بطارية جيب
 بطارية خلية جافة
 نابض التماس
 شريط من الموصلات اللدنة بالحرارة
 سلك صلب السحب ذو مفتاح ملولب وحلقة
 صندوق عداد الكهرباء
 عداد الكهرباء
 قاطع تيار صغير
 شريط عازل
 حامل الصمام (الفيوز)
 قاطع تيار، فيوز ذو عنصر قابل للانصهار
 مؤشر لوني [يبين معدل التيار]
 وصلة العلامس
 مشبك تثبيت الكابل
 عداد اختبار للأغراض العامة (عداد قياس التيار والفولطية)
 كابل لدن مقاوم للرطوبة
 موصل نحاسي
 كابل ذو ثلاثة قلوب
 مشكوة لحام كهربية
 مفك
 زردية فك وربط الأنابيب
 خوذته أمان مقاومة

- [for soldering]
75 sealing tape
76 tin-lead solder
77 club hammer
78 hammer
79 spirit level
80 steel-leg vice (Am. vise)
81 pipe vice (Am. vise)
82 pipe-bending machine
83 former (template)
84 pipe cutter
85 hand die
86 screw-cutting machine (thread-cutting machine)

127 Electrician

- 1 electrician (electrical fitter, wireman)
 2 bell push (doorbell) for low-voltage safety current
 3 house telephone with call button
 4 [flush-mounted] rocker switch
 5 [flush-mounted] earthed socket (wall socket, plug point, Am. wall outlet, convenience outlet, outlet)
 6 [surface-mounted] earthed double socket (double wall socket, double plug point, Am. double wall outlet, double convenience outlet, double outlet)
 7 switched socket (switch and socket)
 8 four-socket (four-way) adapter
 9 earthed plug
 10 extension lead (Am. extension cord)
 11 extension plug
 12 extension socket
 13 surface-mounted three-pole earthed socket [for three-phase circuit] with neutral conductor
 14 three-phase plug
 15 electric bell (electric buzzer)
 16 pull-switch (cord-operated wall switch)
 17 dimmer switch [for

- شريط مانع للتسرب
 سبيكة لحام من القصدير والرصاص
 مطرقة قصيرة اليد
 شاكوش
 ميزان تسوية
 ملزمة بقدم فولاذية (vise)
 ملزمة المواسير
 ماكينة ثني المواسير
 أداة تشكيل (قالب)
 قاطعة المواسير
 لقمة يدوية
 ماكينة قطع اللولب
 الكهربياني
 الكهربياني
 جرس باب انضغاطي يعمل بتيار أمان منخفض الفولطية
 هاتف منزلي ذو زر بدء
 مفتاح كهربائي مزوج
 [مركب تساطحيا]
 مقبس مؤرض [مركب تساطحيا] [مقبس جدارى، مخرج تيار]
 مقبس مزدوج مؤرض
 [مثبت فوق الجدار] [مقبس جدارى مزدوج، مخرج تيار مزدوج]
 شريط عازل
 حامل الصمام (الفيوز)
 قاطع تيار، فيوز ذو عنصر قابل للانصهار
 مؤشر لوني [يبين معدل التيار]
 وصلة العلامس
 مشبك تثبيت الكابل
 عداد اختبار للأغراض العامة (عداد قياس التيار والفولطية)
 كابل لدن مقاوم للرطوبة
 موصل نحاسي
 كابل ذو ثلاثة قلوب
 مشكوة لحام كهربية
 مفك
 زردية فك وربط الأنابيب
 خوذته أمان مقاومة
 جرس أمان متفحض الفولطية
 هاتف منزلي ذو زر بدء
 مفتاح كهربائي مزوج
 [مركب تساطحيا]
 مقبس مؤرض [مركب تساطحيا] [مقبس جدارى، مخرج تيار]
 مقبس مزدوج مؤرض
 [مثبت فوق الجدار] [مقبس جدارى مزدوج، مخرج تيار مزدوج]
 شريط عازل
 حامل الصمام (الفيوز)
 قاطع تيار، فيوز ذو عنصر قابل للانصهار
 مؤشر لوني [يبين معدل التيار]
 وصلة العلامس
 مشبك تثبيت الكابل
 عداد اختبار للأغراض العامة (عداد قياس التيار والفولطية)
 كابل لدن مقاوم للرطوبة
 موصل نحاسي
 كابل ذو ثلاثة قلوب
 مشكوة لحام كهربية
 مفك
 زردية فك وربط الأنابيب
 خوذته أمان مقاومة
 جرس أمان متفحض الفولطية
 هاتف منزلي ذو زر بدء
 مفتاح كهربائي مزوج
 [مركب تساطحيا]
 مقبس مؤرض [مركب تساطحيا] [مقبس جدارى، مخرج تيار]
 مقبس مزدوج مؤرض
 [مثبت فوق الجدار] [مقبس جدارى مزدوج، مخرج تيار مزدوج]
 شريط عازل
 حامل الصمام (الفيوز)
 قاطع تيار، فيوز ذو عنصر قابل للانصهار
 مؤشر لوني [يبين معدل التيار]
 وصلة العلامس
 مشبك تثبيت الكابل
 عداد اختبار للأغراض العامة (عداد قياس التيار والفولطية)
 كابل لدن مقاوم للرطوبة
 موصل نحاسي
 كابل ذو ثلاثة قلوب
 مشكوة لحام كهربية
 مفك
 زردية فك وربط الأنابيب
 خوذته أمان مقاومة

8 mortise (mortice) chisel	أرْمِيل نقر
9 gouge	أرْمِيل مقعر: مِبْطَفَار
10 handle	مقبض
11 framing chisel (cant chisel)	أرْمِيل نقر (أرْمِيل منطوف الحافة)
12 glue pot in water bath	مِغْرَاة في حمام مائي
13 glue pot (glue well), an insert for joiner's glue	مِغْرَاة
14 handscrew	قَامِطَة يدوية
15-28 planes	المساحيق/ الفارات
15 smoothing plane	مَسْحَاح/ فارة تلميس
16 jack plane	مَسْحَاح/ فارة تخشين
17 toothing plane	مَسْحَاح/ فارة تسنين
18 handle (toat)	مقبض
19 wedge	إسفين
20 plane iron (cutter)	سلاح المسحاح/ الفارة
21 mouth	فُوْرَة
22 sole	قاعدة، نعل
23 side	جانِب
24 stock (body)	كلّية (جسم)
25 rebate (rabbet) plane	مَسْحَاح / فارة افتراز
26 router plane (old woman's tooth)	مِسْحَاح تخديد جناح
27 spokeshave	مِسْحَاح تقعير/ تسنيم ذو مقبضين
28 compass plane	مَسْحَاح/ فارة منحنيات
29-37 woodworker's bench	طاولة عامل الخشب/ النجار
29 foot	قاعدة
30 front vice (Am. vise)	مِلْزِمة أمامية
31 vice (Am. vise) handle	ذِرَاع المِلْزِمة
32 vice (Am. vise) screw	لُؤْلُب المِلْزِمة
33 jaw	فك المِلْزِمة
34 bench top	سطح الطاولة
35 well	بنر
36 bench stop (bench holdfast)	مِحْد الطاولة
37 tail vice (Am. vise)	مِلْزِمة خلفية
38 cabinet maker (joiner)	نَجَّار الدواليب
39 tryng plane	مَسْحَاح/ فارة نسوية
40 shavings	قَشَّارة، برابة
41 wood screw	برغي خشب
42 saw set	مُتَلَفِّجة مناشير
43 mitre (Am. miter) box	مُتَوَرِّق القطع المائل
44 tenon saw	مِشَّار تسنين
45 thicknesser (thicknessing machine)	مَأْكِيَة تتخين
46 thicknessing table with rollers	طاولة تتخين ذات اسطوانات
47 kick-back guard	واقى الإرتداد
48 chip-extractor opening	فتحة طرد النحانة
49 chain mortising machine (chain mortiser)	مَأْكِيَة نقر ذات بسلسلة
50 endless mortising chain	سلسلة مأكية نقر متصلة
51 clamp (work clamp)	قَامِطَة، ملزّمة
52 knot hole moulding (Am. molding) machine	مَأْكِيَة تشكيل الأفاريز
53 knot hole cutter	والحلي المنقبة سكينة الثقوب الأنشوية

5 stepladder	سُلّم درّجِي
6 can (tin) of paint	صفحة الدهان/ الطلاء
7-8 cans (tins) of paint	صفائح الدهان/ الطلاء
7 can (tin) with fixed handle	صفحة ذات مقبض ثابت
8 paint kettle	سِنطَل الطلاء
9 drum of paint	برْمِيل طلاء
10 paint bucket	دَلُو طلاء
11 paint roller	رول الدهن
12 grill [for removing excess paint from the roller]	جريل [شبكة مُصْنَعَة لإزالة الطلاء الزائد من الرول]
13 stippling roller	رول ترقيط الطلاء
14 varnishing	الوَرْنِشَة، الدهان بالورنيش
15 oil-painted dado	جزء سفلي من الجدار مدهون بالزيت
16 canister for thinner	عَلْبَة التَنْر (مادة مُرَفِّقة للوقام)
17 flat brush for larger surfaces (flat wall brush)	فُرْشَاة مستوية للأسطح الكبيرة المستوية
18 stippler	فُرْشَاة الدهان المُرَقِّط
19 fitch	فُرْشَاة شعر
20 cutting-in brush	فُرْشَاة مزج
21 radiator brush (flay brush)	فُرْشَاة طلاء المَشْبَعَات/ كشط
22 paint scraper	مِخْطَطة طلاء
23 scraper	مِخْطَطة يدوية
24 putty knife	سِكِّين مَخْبِئَة/ المَعْجُون
25 sandpaper	وَرَق سفرة
26 sandpaper block	كلّية وَرَق السفرة
27 floor brush	فُرْشَاة للأرضية
28 sanding and spraying	السفرة والرش
29 grinder	جِلَّاحَة
30 sander	مَأْكِيَة سفرة
31 pressure pot	وعاء ضغط
32 spray gun	مسدس رش
33 compressor (air compressor)	ضامِط هواء
34 flow coating machine for flow coating radiators, etc.	مَأْكِيَة طلي معدني لطلاء المشبّعات، الخ.
35 hand spray	رشاش يدوي
36 airless spray unit	وحدة رش تعمل بدون هواء مضغوط
37 airless spray gun	مسدس رش يعمل بدون هواء مضغوط
38 efflux viscometer	مقياس درجة اللزوجة
39 seconds timer	جهاز توقيت التواني
40 lettering and gilding	نقش الحروف والكتسبية
41 lettering brush (sign-writing brush, pencil)	ريشة كتابة الحروف (قلم)
42 tracing wheel	عجلة استشفاف
43 stencil knife	سكين استنسل
44 oil gold size	مادة غروية من الذهب الزيتي
45 gold leaf	ورقة ذهب

46 outline drawing	رسم تمهيدي
47 mahlstick	تَكَة الرسم
48 pouncing	تجفيف بالذرور
49 pounce bag	كيس الذرور
50 gilder's cushion	وسادة عامل الطلاء بالذهب
51 gilder's knife	سكين عامل الطلاء بالذهب
52 sizing gold leaf	مُعالِجَة وَرَق الذهب بمادة غروية
53 filling in the letters with stipple paint	ملء الحروف بطلاء مرقط
54 gilder's mop	مِكنسة عامل الطلاء بالذهب

130 Cooper and Tank Construction Engineer

1-33 cooper's and tank construction engineer's workshops	ورشة مهندس تصنيع البراميل الخشبية والخزانات
1 tank	خزان، صهرج
2 circumference made of staves (staved circumference)	جدار خارجي مصنوع من الشرائح الخشبية
3 iron rod	قضيب حديد
4 turnbuckle	شدادة، شكال مَلَوْب
5 barrel (cask)	برْمِيل (برْمِيل خشبي)
6 body of barrel (of cask)	جسم البرميل
7 bunghole	ثقب البرميل
8 band (hoop) of barrel	طَوِّق البرميل
9 barrel stave	شريحة خشبية
10 barrelhead (heading)	رأس البرميل
11 cooper	صانع البراميل الخشبية
12 trusser	مَأْكِيَة تثبيت أطواق البرميل
13 drum	أُسْطُوآنَة البرْمِيل
14 gas welding torch	جَمَلِاح اللحام بالغاز
15 staining vat, made of thermoplastics	خوض صبغ مصنوع من اللدائن الحرارية
16 iron reinforcing bands	شرائط تقوية مصنوعة من الحديد
17 storage container, made of glass fibre (Am. glass fiber) reinforced polyester resin	حاوية تخزين مصنوعة من الراتنج المقوى بالألياف الزجاجية
18 manhole	فتحة الدخول
19 manhole cover with handwheel	غطاء فتحة دخول ذو عجلة يدوية
20 flange mount	شَفَّة تركيب
21 flange-type stopcock	محبس بشفة
22 measuring tank	خزان قياس
23 shell (circumference)	جدار، غلاف
24 shrink ring	حلقة انكماشية
25 hot-air gun	مسدس الهواء الساخن
26 roller made of glass fibre (Am. glass fiber) reinforced synthetic resin	دولفين من الراتنج الصناعي المقوى بألياف زجاجية
27 cylinder	أُسْطُوآنَة
28 flange	شَفَّة
29 glass cloth	قماش زجاجي
30 grooved roller	دولفين مُخَدَّد

31 lambskin roller	دولفين من جلد الغنم
32 ladle for testing viscosity	مِغْرَفَة لاختبار درجة اللزوجة
33 measuring vessel for hardener	وعاء قياس المقسّي/مُجَلِّد التصليد

131 Furrier

1-25 furrier's workshop	مُصنَع الملابس الفرائية
1 furrier	الفراء، دباغ الملابس الفرائية
2 steam spray gun	مسدس رش البخار
3 steam iron	مِكْوَاة بخارية
4 beating machine	مَأْكِيَة الضرب
5 cutting machine for letting out furskins	مَأْكِيَة تقطع جلود الفراء
6 uncut furskin	جلد فراء لم يقطع بعد
7 let-out strips (let-out sections)	قطع مطولة من الفراء
8 fur worker	عامله حياكة الملابس الفرائية
9 fur-sewing machine	مَأْكِيَة حياكة الفراء
10 blower for letting out	مرّوحة تفتح قطع الفراء
11-21 furskins	جلود الفراء
11 mink skin	جلد حيوان المئك
12 fur side	جانِب فرائي
13 leather side	جانِب جلدي
14 cut furskin	فراء مُقَطَّع
15 lynx skin before letting out	جلد حيوان الوشق قبل تقطيعه وتطويله
16 let-out lynx skin	قطع مطولة من جلد حيوان الوشق
17 fur side	الجانِب الفرائي
18 leather side	الجانِب الجلدي
19 let-out mink skin	قطع مطولة من جلد حيوان المئك
20 lynx fur, sewn together (sewn)	فراء الوشق مُحَاك معا
21 broadtail	جلد حَمَل الفَرَكُول
22 fur marker	دبابيس الفراء
23 fur worker	عامله حياكة الملابس الفرائية
24 mink coat	معطف من فراء المئك
25 ocelot coat	معطف من فراء الأملوت

132 Joiner I

1-73 joiner's workshop	ورشة نجار الأثاثات
1-28 joiner's tools	أدوات نجار الأثاثات
1 wood rasp	مِرْد خشب مَحْبَب القطعية
2 wood file	مِرْد خشب
3 compass saw (keyhole saw)	مِشَّار منحنيات (مِشَّار تقريع الثقوب)
4 saw handle	مقبض المِشَّار
5 [square-headed] mallet	مِطْرَقَة [مربعة الرأس]
6 try square	زَاوِيَة ضبط قائمة، زاوية النجار
7-11 chisels	الأزاميل
7 bevelled-edge chisel (chisel)	أرْمِيل ذو حافة مُشْطَوقة

electric drill	مِشْأَر دَائِرِي أَزَارُ وَ مِشْأَر شَرِيطِي مَعَا
50 combined circular saw (buzz saw) and band-saw	مِخْرَطَةُ الخشب
51 wood-turning lathe	مِشْأَر دَائِرِي
52 circular saw attachment	مَأْكِيَةٌ سَفْرَةٌ مَدَارِيَةٌ
53 orbital sanding attachment (orbital sander)	حَامِلُ المَقْبَعِ
54 drill stand	مَأْكِيَةٌ تَهْدِيْبُ السِّيَاحِ
55 hedge-trimming attachment (hedge trimmer)	مَسْدَسُ لحام
56 soldering gun	مِكْوَاةُ لحام
57 soldering iron	مِكْوَاةُ لحام عَالِيَةِ السَّرْعَةِ
58 high-speed soldering iron	التَّجْيِيدُ، تَجْيِيدُ كَرْسِي ذِي ذِرَاعِيْن
59 upholstery, upholstering an armchair	قَمَاشِ تَجْيِيدِ
60 fabric (material) for upholstery	شَخْصٌ يَاقُومُ بِإِصْلَاحِ الشَّيْءِ بِنَفْسِهِ (دُونَ الْحَاجَةِ إِلَى اِخْتِصَاصِي)
61 do-it-yourself enthusiast	
135 Turner	الْحِزْرَاطُ
1-26 turnery (turner's workshop)	وَرِثَةُ خِرَاطَةِ
1 wood-turning lathe (lathe)	مِخْرَطَةُ الخشب
2 lathe bed	فِرْشَةُ المِخْرَطَةِ
3 starting resistance (starting resistor)	مَقَاوِمَةُ البِدَاءِ
4 gearbox	عَلْمَةُ تَرَوَسِ السَّرْعَةِ
5 tool rest	مِسْنَدُ قَلَمِ المِخْرَطَةِ
6 chuck	طُرْفُ
7 tailstock	غَرَابِ مَحْرُوكِ، غَرَابِ الذَيْلِ
8 centre (Am. center)	ذَنْبَةُ المِخْرَطَةِ
9 driving plate with pin	قُرْصُ التَّدْوِيرِ
10 two-jaw chuck	طُرْفُ ذُو فَكَيْنِ
11 live centre (Am. center)	ذَنْبَةُ ذَوْرَانِيَّةِ
12 fretsaw	مِشْأَرُ مَنَحْنِيَاتِ / زِخْرَفَةِ
13 fretsaw blade	نَضَلُ مِشْأَرِ المَنَحْنِيَاتِ / الزِخْرَفَةِ
14, 15, 24 turning tools	أَدْوَاتُ الحِزْرَاطِ
14 thread chaser, for cutting threads in wood	مِمْشَلُ لَوَلِيَّةِ
15 gouge, for rough turning	مِظْفَارُ / أَرْمِيلُ مَفْعَرِ الحِزْرَاطِ
16 spoon bit (shell bit)	لَقْمَةُ حَفْرِ مَلْعِيَّةِ التَّجْوِيْفِ
17 hollowing tool	أَدَاةُ تَجْوِيْفِ
18 outside calliper (caliper)	فِرْجَاجُ قِيَاسِ خَارِجِي
19 turned work (turned wood)	قِطْعَةُ خَشْبِ مَخْرُوطَةٍ
20 master turner (turner)	رَئِيسُ الحِزْرَاطِيْنِ
21 [piece of] rough wood	قِطْعَةُ خَشْبِ خَشَلَةٍ
22 drill	مِثْقَابُ
23 inside calliper (caliper)	فِرْجَاجُ قِيَاسِ دَاخِلِي
24 parting tool	قَلَمُ قَطْعِيَّةِ
25 glass paper (sandpaper, emery paper)	وَرَقُ سَفْرَةٍ

5 cross-point screwdriver	مِفْكَ ذُو طُرْفِ مُتَصَالِبِ
6 saw rasp	مِيزِدُ شَحْطِ مَنَاشِيْرِ مَحْبَبِ الضَّطْعِيَّةِ
7 hammer	مِطْرَقَةٌ، شَاكُوشُ
8 wood rasp	مِيزِدُ خَشْبِ
9 routing file	مِيزِدُ تَحْضِيْنِ
10 small vice (Am. vise)	مِلْزَمَةٌ صَغِيرَةٌ
11 corner pipe wrench	مِفْطَاحُ رِبْطِ الأَنْبِيْبِ
12 water pump pliers	زُرْدِيَّةُ رِبْطِ المَوَاسِيْرِ
13 pincers	كِنَاشَةُ
14 all-purpose wrench	مِفْطَاحُ رِبْطِ لَجْمِيعِ الأَعْرَاضِ
15 wire stripper and cutter	بِنْدَةُ تَعْوِيَةِ الأَسْفَلاكِ المَعزُولَةِ وَقَطْعِهَا
16 electric drill	مِثْقَابُ (مِشْأَر) كَهْرَبِي
17 hacksaw	مِشْأَرُ مَعَادِنِ
18 plaster cup	سَطْلُ عَجْنِ الجِيبِ
19 soldering iron	مِكْوَاةُ لحام
20 tin-lead solder wire	سَلْكُ لحامِ مَصنُوعِ مِنْ القَصْدِيْرِ وَ الرِّضَاصِ
21 lamb's wool polishing bonnet	خِرْقَةٌ تَلْمِيْعِ مَصنُوعَةٍ مِنْ صُوفِ الأَنْعَامِ
22 rubber backing disc (disk)	قُرْصُ اسْتِدْأَانِ مِطَاطِي
23 grinding wheel	عَجَلَةُ تَجْلِيْحِ
24 wire wheel brush	فِرْشَاةُ سَلْكِ ذُو لَوَايِبَةِ الشَّكْلِ
25 sanding discs (disks)	أَقْرَاصُ سَفْرَةٍ
26 try square	زَاوِيَّةُ ضَبْطِ قَاشَةِ، زَاوِيَّةِ التَّجَارِ
27 hand saw	مِشْأَرُ يَدَوِي
28 universal cutter	أَدَاةُ قَطْعِ عَامَةٍ
29 spirit level	مِيزَانُ تَسْوِيَةٍ
30 firmer chisel	أَرْمِيلُ قَطْعِ بِالدَّقِ
31 centre (Am. center) punch	سَبْكُ تَعْلِيمِ المَرْكَزِ
32 nail punch	سَبْكُ السَّمَامِيْرِ
33 folding rule (rule)	مِسْطَرَةٌ قَابِلَةٌ لِلطِّي
34 storage box for small parts	صَنْدُوقُ حِفْظِ القِطْعِ الصَّغِيرَةِ
35 tool box	صَنْدُوقُ العُدَّةِ
36 woodworking adhesive	غَرَاءُ المَصنُوعَاتِ الخَشْبِيَّةِ
37 stripping knife	سَكِيْنُ تَقْطِيْرِ
38 adhesive tape	شَرِيْطُ لَاصِقِ
39 storage box with compartments for nails, screws, and plugs	صَنْدُوقُ حِفْظِ التَّخْزِيْنِ لَهُ حِجْرَاتُ السَّمَامِيْرِ وَ الرِّبَاطِي وَ السَّادَاتِ
40 machinist's hammer	شَاكُوشُ
41 collapsible workbench (collapsible bench)	طَاوَلَةُ شَعْلِ قَابِلَةٌ لِلطِّي
42 jig	دَلِيْلُ تَشغِيْلِ
43 electric percussion drill (electric hammer drill)	مِثْقَابُ حَفْرِ بِالدَّقِ يَعمَلُ بِالكَهْرَبِيَاءِ
44 pistol grip	قَبْضَةُ مَسْدَسِ
45 side grip	مِقْبِضُ جَانِبِي
46 gearshift switch	مِفْطَاحُ تَبْدِيلِ السَّرْعَةِ
47 handle with depth gauge (Am. gage)	ذِرَاعُ ذُو مِيعَارٍ لِلعمقِ
48 chuck	طُرْفُ لَقْمِ المَقْبَعِ
49 twist bit (twist drill)	لَقْمَةُ حَفْرِ حَزْرَوِيَّةِ
50-55 attachments for an	مِلْحَقَاتُ لِلْمِثْقَابِ الكَهْرَبِي

20 opening dust hood	حَاوِيَّةُ نِشَارَةٍ مَفْتُوحَةٍ
21 rise adjustment of the table	أَلْيَّةُ ضَبْطِ ارْتِفَاعِ الطَاوَلَةِ
22 rise adjustment wheel for the table	عَجَلَةٌ ضَبْطِ ارْتِفَاعِ الطَاوَلَةِ
23 clamping screw for the table rise adjustment	بِرغِي تَثْبِيْتِ أَلْيَّةِ ضَبْطِ ارْتِفَاعِ الطَاوَلَةِ
24 console	كُونَسُولُ
25 foot of the machine	قَاعِدَةُ المَأْكِيَّةِ
26 edge-veneering machine	مَأْكِيَّةُ تَكْشِيْفَةِ الحِوَالِ
27 sanding wheel	عَجَلَةُ السَفْرَةِ
28 sanding dust extractor	أَلْيَّةُ طَرْدِ نِشَارَةِ السَفْرَةِ
29 splicing head	رَأْسُ الجِذَلِ / القَرْنِ بِالتَّرَاكِبِ
30 single-belt sanding machine (single-belt sander)	مَأْكِيَّةُ سَفْرَةٍ ذَاتِ سَبْرٍ وَاحِدِ
31 belt guard	وَقَاءُ السَبْرِ
32 band wheel cover	غِطَاءُ بِكْرَةِ السَبْرِ
33 extractor fan (exhaust fan)	مِرْوَحَةٌ طَارِدَةٌ
34 frame-sanding pad	مَسْدُ السَفْرَةِ لِلرَّابُوِيْزِ / لِلإِطَارَاتِ
35 sanding table	طَاوَلَةُ السَفْرَةِ
36 fine adjustment	أَلْيَّةُ الضَّبْطِ الدَّقِيْقِ
37 fine cutter and jointer	جِهَازُ القِطْعِ وَ الجِذَلِ الدَّقِيْقِ
38 saw carriage with chain drive	حَامِلُ المِشْأَرِ ذُو إِدَارَةٍ بِسِلْسَلَةٍ
39 trailing cable hanger (trailing cable support)	حَامِلُ الكَبْلِ الخَلْفِي
40 air extractor pipe	أَنْبُوبُ طَرْدِ الهِوَاءِ
41 rail	قَضَبِي، دَرَابِيْزِيْنِ
42 frame-clamping (frame-clamping) machine	مَأْكِيَّةُ قَطْمِ الإِطَارَاتِ
43 frame stand	حَامِلُ الإِطَارِ
44 workpiece, a window frame	قِطْعَةُ الشَّغْلِ، إِطَارُ نَافِذَةٍ
45 compressed-air line	خَطُ هِوَاءِ مَضْغُوطِ
46 pressure cylinder	أَسْطُوَانَةٌ الضَّغْطِ
47 pressure foot	قَاعِدَةُ أَسْطُوَانَةِ الضَّغْطِ
48 frame-mounting device	جِهَازُ تَثْبِيْتِ الإِطَارِ
49 rapid-veneer press	مَكْبَسُ التَكْشِيْفِ بِالقَشُورِ
50 bed	فِرْشَةٌ، سَرِيْرُ
51 press	مِكْبَسُ
52 pressure piston	كَبَاسُ ضَغْطِ
134 Do-it-yourself	مُعَدَّاتُ الإِصْلَاحَاتِ المَعْمُوْلِيَّةِ
1-34 tool cupboard (tool cabinet) for do-it-yourself work	خِزْرَانَةُ أَدْوَاتِ "اصْنَعِ الشَّيْءَ بِنَفْسِكَ" (دُونَ الْحَاجَةِ إِلَى اِخْتِصَاصِي)
1 smoothing plane	مِسْمَاحُ تَلْمِيْسِ / تَنْعِيْمِ
2 set of fork spanners (fork wrenches, open-end wrenches)	مَاقِمُ مِنْ مَقَاتِيْحِ الرِبْطِ المُنْشَعِبَةِ
3 hacksaw	مِشْأَرُ مَعَادِنِ
4 screwdriver	مِفْكَ

54 quick-action chuck	طُرْفُ لَقْمِ المَقْبَعِ
55 hand lever	عَطْلَةٌ يَدَوِيَّةٌ
56 change-gear handle	ذِرَاعُ تَبْدِيلِ السَّرْعَةِ
57 sizing and edging machine	مَأْكِيَّةُ تَطْفِيْفِ وَ مِيعَارِيَةِ المَقَاسِ
58 main switch	مِفْطَاحُ التَشغِيْلِ الرَّأْسِي
59 circular-saw (buzz saw) blade	نَضَلُ مِشْأَرِ دَائِرِي أَزَارُ
60 height (rise and fall) adjustment wheel	عَجَلَةٌ ضَبْطِ الارتفاعِ
61 V-way	مِجْرَى مُتَلَطِّئِ المَقْطَعِ
62 framing table	طَاوَلَةُ تَشْكِيلِ الإِطَارَاتِ / الرَّابُوِيْزِ
63 extension arm (arm)	ذِرَاعُ اسْتِطَالَةٍ
64 trimming table	طَاوَلَةُ التَهْدِيْبِ
65 fence	حَاجِزٌ، مِصْدُ
66 fence adjustment handle	ذِرَاعُ ضَبْطِ الحَاجِزِ
67 clamp lever	ذِرَاعُ تَثْبِيْتِ
68 board-sawing machine	مَأْكِيَّةُ نِشْرِ الأَوْحَادِ الخَشْبِيَّةِ
69 swivel motor	مَوْتُورُ دَوَائِرِ
70 board support	حَامِلُ اللُوحِ الخَشْبِي
71 saw carriage	حَاضِيَةُ المِشْأَرِ
72 pedal for raising the transport rollers	ذَوَاسَةُ رَفْعِ أَسْجِيْنَاتِ نِظَامِ النَقْلِ
73 blockboard	كَلَّةُ اللُوحِ الخَشْبِي
133 Joiner II	فَجَّارُ الأَثَاثِ (2)
1 veneer-peeling machine (peeling machine, peeler)	مَأْكِيَّةُ تَقْشِيْرِ الخَشْبِ
2 veneer	قَشْرَةُ خَشْبِيَّةِ
3 veneer-splicing machine	مَأْكِيَّةُ جِذَلِ القَشُورِ الخَشْبِيَّةِ
4 nylon-thread cop	كَبْجَةُ غَزْلِ الخِيطِ النَيْلُونِ
5 sewing machine	أَلْيَّةُ الخِيَاطَةِ
6 dowel hole boring machine (dowel hole borer)	مَأْكِيَّةُ ثَقْبِ فِجَوَاتِ الدَّسَارِ
7 boring motor with hollow-shaft boring bit	مَوْتُورُ ثَقْبِ مَزُودِ بِمِثْقَابِ حَفْرِ لَهُ عَمُودُ أَوْجُوفِ
8 clamp handle	ذِرَاعُ القَابِضَةِ / المِلْزَمَةِ
9 clamp	قَابِضَةٌ، مِلْزَمَةٌ
10 clamping shoe	حِذَاءُ قَطْمِ / تَثْبِيْتِ
11 stop bar	حَاجِزُ
12 edge sander (edge-sanding machine)	مَأْكِيَّةُ سَفْرَةِ الحِوَالِ
13 tension roller with extension arm	أَسْطُوَانَةٌ شَدِّ ذَاتِ ذِرَاعِ اِمْتِدَادِي
14 sanding belt regulator (regulating handle)	مُنْتَلَمٌ سَبْرِ السَفْرَةِ
15 endless sanding belt (sand belt)	سَبْرُ سَفْرَةٍ مُتَصَلِ
16 belt-tensioning lever	ذِرَاعُ شَدِّ السَبْرِ
17 canting table (tilting table)	طَاوَلَةُ إِمَالَةٍ
18 belt roller	أَسْطُوَانَةُ السَبْرِ
19 angling fence for mitres (Am. miters)	حَاجِزُ زَوَايَةِ اللَاسِطِ المُنْشَوْبَةِ الزَاوِيَّةِ

26 shavings	نحاتة، قراضة، براية
136 Basket Maker 1-40 basket making (basketry, basketwork)	السلال (صانع السلال) صناعة السلال
1-4 weaves (strokes)	أنسجة سلالية
1 randing	أملود منجدول
2 rib randing	جدل ضلعي
3 oblique randing	جدل مائل
4 randing, a piece of wickerwork (screen work)	نسيج، قطعة من الأماليد المجدولة
5 weaver	نَسَّاج، ناسج
6 stake	عود (صفصاف)
7 workboard; <i>also:</i> lap-board	سطح الشغل
8 screw block	قالب تثبيت العيدان
9 hoic for holding the block	تعب لتثبيت القالب
10 stand	حامل
11 chip basket (spale basket)	سلة من رقاقات القش
12 chip (spale)	رقاقة من القش
13 soaking tub	حوض النقع في الماء
14 willow stakes (osier stakes)	عيدان الصفصاف
15 willow rods (osier rods)	عصيان الصفصاف
16 basket, ▀ piece of wickerwork (basketwork)	سلة، قطعة من الأماليد المجدولة
17 border	حاشية، كتار
18 woven side	جانِب منسوج
19 round base	قاعدة مسديرة
20 woven base	قاعدة منسوجة
21 slath	جديلة
22-24 covering a frame	تغطية الإطار
22 frame	إطار
23 end	طَرَف الأملود
24 rib	ضلع
25 upsett	إطار ذو أضلع مغلطة
26 grass; <i>kinds:</i> esparto grass, alfalfa grass	نجيل، أنواعه الخلفاء والفصصة
27 rush (bulrush, reed mace)	سمار (نبات)
28 reed	منشط
29 raffia (bast)	ليف نخل الرافية
30 straw	قش
31 bamboo cane	خيزران
32 rattan (ratan) chair cane	خيزران الروطان المستخدم في صنع الكراسي
33 basket maker	صانع السلال
34 bending tool	أداة ثني
35 cutting point (bodkin)	سن القطع (مخرز)
36 rapping iron	قضيب خلطة بالدققة
37 pincers	كماشة
38 picking knife	سكين قطف
39 shave	شريحة
40 hacksaw	مبشار معادن

137 Blacksmith (Smith) I	الحداد (1)
1-8 hearth (forge) with blacksmith's fire	كورة الحداد
1 hearth (forge)	مجمر، كورة
2 shovel (slice)	مجرفة
3 swab	فرشاة ترطيب
4 rake	مدبنة
5 poker	مخزك (الجمر)، سيخ تقليب الجمر
6 blast pipe (tue iron)	ماسورة الفع (أقسام الكور الثقالي)
7 chimney (cowl, hood)	مدخنة
8 water trough (quenching trough, bosh)	وعاء ماء التقيئة
9 power hammer	مطرقة آلية
10 ram (tup)	مكبس، مطرقة، مدك
11-16 anvil	المسدان
11 anvil	سدان
12 flat beak (beck, bick)	طرف السدان المفلطح
13 round beak (beck, bick)	طرف السدان المستدير
14 auxiliary table	ضد مساند
15 foot	قاعدة
16 upsetting block	كتلة اللطحة بالطرق على الساخن
17 swage block	زهرة طرق
18 tool-grinding machine (tool grinder)	ماكينة تجليخ العدة
19 grinding wheel	عجلة التجليخ
20 block and tackle	بكرة وكبل
21 workbench (bench)	طاولة الشغل
22-39 blacksmith's tools	أدوات الحداد
22 sledge hammer	مرزبة
23 blacksmith's hand hammer	شاكوش يدوي، مطرقة يدوية
24 flat tongs	ملقط مفلطح الطرف
25 round tongs	ملقط مستدير الطرف
26 parts of the hammer	أجزاء المطرقة/الشاكوش
27 peen (pane, pein)	حدا المطرقة
28 face	وجه المطرقة
29 eye	عروة
30 haft	مقبض
31 cotter punch	سنك سفيني
32 hardy (hardie)	مقطعة الحداد (سدان)
33 set hammer	مطرقة تسطیح
34 sett (set, sate)	أزميل قطع مطرقي الشكل
35 flat-face hammer (flatter)	مطرقة مفلطحة
36 round punch	سنك محذب (دائري المقطع)
37 angle tongs	ملقط بزائوية
38 blacksmith's chisel (scaling hammer, chip-ping hammer)	أزميل الحداد (مطرقة التفتيش)
39 moving iron (bending iron)	قضيب الثني

138 Blacksmith (Smith) II (Farm Vehicle Engineering)	الحداد (2) (هندسة المركبات الزراعية)
1 compressed-air system	جهاز الهواء المضغوط
2 electric motor	محرك كهربوي
3 compressor	ضاغط
4 compressed-air tank	أسطوانة الهواء المضغوط
5 compressed-air line	خراطيم/خط الهواء المضغوط
6 percussion screwdriver	مفك يعمل بالصدمة
7 pedestal grinding machine (floor grinding machine)	ماكينة تجليخ بقاعدة
8 grinding wheel	عجلة التجليخ
9 guard	وقاء
10 trailer	مقطورة
11 brake drum	أسطوانة الفرامل، طبله المكبح
12 brake shoe	حذاء الفرامل/المكبح
13 brake lining	بطانة الفرامل/المكبح
14 testing kit	صندوق أدوات الاختبار
15 pressure gauge (Am. gage)	مقياس الضغط
16 brake-testing equipment, ▀ rolling road	معدات اختبار الفرامل/المكبح
17 pit	بئر، حفرة
18 braking roller	أسطوانة الفرامل/المكبح
19 meter (recording meter)	عداد قياس
20 precision lathe for brake drums	مخزطة دقيقة لضبط
21 lorry wheel	دولاب شاحنة
22 boring mill	ماكينة حفر عمودي
23 power saw, ▀ hacksaw (power hacksaw)	مبشار معادن كهربائي
24 vice (Am. vise)	ملزمة، منجدة
25 saw frame	إطار المبشار
26 coolant supply pipe	أنبوب إمداد المظلول المبرد
27 riveting machine	ماكينة برشمة
28 trailer frame (chassis) under construction	شاسيه مقطورة تحت التصنيع
29 inert-gas welding equipment	معدات اللحام في محيط من الغاز الخامل
30 rectifier	مقوم
31 control unit	وحدة التحكم
32 CO ₂ cylinder	أسطوانة ثاني أكسيد الكربون
33 anvil	سدان
34 hearth (forge) with blacksmith's fire	كورة الحداد، مجمر
35 trolley for gas cylinders	تروالي أسطوانات الغاز
36 vehicle under repair, ▀ tractor	جرار تحت التصليح
139 Hammer Forging (Smith Forging) and Drop Forging	تشكيل المعادن بالطرق
1 continuous furnace	فرن من النوع المتواصل

with grid hearth for annealing of round stock	ذو مجمرية شبكية لتضمير الخام
2 discharge opening (discharge door)	فتحة تفريغ الخامات
3 gas burners	مواعد الغاز
4 charging door	بوابة شحن الخامات
5 counterblow hammer	المطرقة ضربات متضادة
6 upper ram	رأس طرق علوية
7 lower ram	رأس طرق سفلية
8 ram guide	دليل رأس الطرق
9 hydraulic drive	إدارة هيدروليكية
10 column	قائم، عمود
11 short-stroke drop hammer	مطرقة متساوقة قصيرة الشوط
12 ram (tup)	رأس الطرق
13 upper die block	القالب العلوي
14 lower die block	القالب السفلي
15 hydraulic drive	إدارة هيدروليكية
16 frame	الهيكل
17 anvil	سدان
18 forging and sizing press	مكبس التشكيل وضبط المقاسات
19 standard	حامل عمودي
20 table	منضدة
21 disc (disk) clutch	قابض قرصي
22 compressed-air pipe	أنبوب الهواء المضغوط
23 solenoid valve	صمام يشغل بملف لولبي
24 air-lift gravity hammer (air-lift drop hammer)	مطرقة متساوقة تعمل بالدفع الهوائي
25 drive motor	محرك الإدارة
26 hammer (tup)	مطرقة
27 foot control (foot pedal)	آلية تحكم تعمل بالقدم
28 reshaped (blocked) workpiece	قطعة الشغل قبل تشكيلها
29 hammer guide	دليل المطرقة
30 hammer cylinder	أسطوانة هواء المطرقة
31 anvil	سدان
32 mechanical manipulator to move the workpiece in hammer forging	مناول ميكانيكي لتحريك قطعة الشغل في عملية التشكيل بالمطرقة
33 dogs	كلابان، ماسكان
34 counterweight	ثقل موازن
35 hydraulic forging press	مكبس تشكيل هيدروليكي
36 crown	تاج
37 cross head	طربوش الوصل
38 upper die block	كتلة اللقمة العلوية
39 lower die block	كتلة اللقمة السفلية
40 anvil	سدان
41 hydraulic piston	كباس هيدروليكي
42 pillar guide	دليل القائم
43 rollover device	آلية قلابة
44 burden chain (chain sling)	معلق سلسلة
45 crane hook	خطاف المرفاع
46 workpiece	قطعة الشغل
47 gas furnace (gas-fired)	فرن يعمل بالغاز

48 gas burner	موقد غازي
49 charging opening	فتحة شحن الخامات
50 chain curtain	ستارة من السلاسل
51 vertical-lift door	باب رفع رأسي
52 hot-air duct	منجزي الهواء الساخن
53 air preheater	سُنْحَن هواء مُتَقَدِّم
54 gas pipe	أَنْبُوب الغاز
55 electric door-lifting mechanism	آلية كهربية لرفع الباب
56 air blast	نَفْع الهواء
140 Metalworker	عامل تَشْغِيل المَعَادِن
1-22 metalwork shop	وَرْتِنَة الأَشْغَال المَعْدِنِيَّة
(mechanic's workshop, fitter's workshop, locksmith's workshop)	(وَرْتِنَة الميكانيكي/البرَّاد / صانع الأقفال)
1 metalworker (e.g. mechanic, fitter, locksmith; form. also: wrought-iron craftsman)	عامل تشغيل معادن (برَّاد، صانع أقفال)
2 parallel-jaw vice (<i>Am. vise</i>)	ملزّمة متوازية الفكين
3 jaw	فك
4 screw	لولب، مِسْمار ملولب
5 handle	ذراع
6 workpiece	قطعة الشغل
7 workbench (bench)	طاولة الشغل
8 files (<i>kinds</i> : rough file, smooth file, precision file)	مِيارِد (أنواعها مِيارِد خشن، مِيارِد أمس، مِيارِد البرَّاد الدقيق)
9 hacksaw	مِشار معادن
10 leg vice (<i>Am. vise</i>), a spring vice	ملزّمة قَدَمِيَّة
11 muffle furnace, a gas-fired furnace	فُرن إجماع خارجي، فُرن لاقع، فُرن يُشْعَل بالغاز
12 gas pipe	أَنْبُوب الغاز
13 hand brace (hand drill)	مِقْطاب يدوي
14 swage block	زهرة طرق
15 filing machine	مكّنة برَّاد
16 file	مِيارِد
17 compressed-air pipe	أَنْبُوب هواء مضغوط
18 grinding machine (grinder)	مكّنة تجليخ (جلاخة)
19 grinding wheel	عَجَلَة تجليخ
20 guard	وقاء
21 goggles (safety glasses)	نظارات واقية من البُهر
22 safety helmet	خوذة أمان
23 machinist's hammer	مطرقة البرَّاد
24 hand vice (<i>Am. vise</i>)	ملزّمة يدوية
25 cape chisel (cross-cut chisel)	أرْمِيل تخديد
26 flat chisel	أرْمِيل مفلطح الحد
27 flat file	مِيارِد مسطح
28 file cut (cut)	قطعية المِيارِد
29 round file (<i>also</i> : half-round file)	مِيارِد دائري المقطع (أيضاً مِيارِد نصف دائري المقطع)
30 tap wrench	مِقْطاح ربط ذكر اللولبية

31 reamer	بُرْغَل، مَوْسَع الثقوب
32 die (die and stock)	لقمة اللولبية
33-35 key	مِقْطاح
33 stem (shank)	ساق
34 bow	قوس (رأس)
35 bit	سن المِقْطاح (لسان)
36-43 door lock, a mortise (mortice) lock	قفْل باب، كِيلُون باب
36 back plate	اللوحة الخلفية
37 spring bolt (latch bolt)	رتاج ذو نابض، سقاطة مزلاج
38 tumbler	لسان القفل
39 bolt	مزلاج
40 keyhole	ثقب المِقْطاح
41 bolt guide pin	مِشْمار دليلي للمزلاج
42 tumbler spring	نابض لسان القفل
43 follower, with square hole	رادف ذو ثقب مربع
44 cylinder lock (safety lock)	قفْل أسطواناني (قفْل أمان)
45 cylinder (plug)	أَسْطُوَانَة
46 spring	نابض
47 pin	مِشْمار
48 safety key, a flat key	مِقْطاح أمان
49 lift-off hinge	مفصلة من جزئين قابلين للفصل
50 hook-and-ride band	مفصلة خطاف وراكب
51 strap hinge	مفصلة بِنِجَاح واحد
52 vernier calliper (caliper) gauge (<i>Am. gage</i>)	مقياس ذو قَدَمَة وَرْتِنِيَّة
53 feeler gauge (<i>Am. gage</i>)	مقياس تحسسي
54 vernier depth gauge (<i>Am. gage</i>)	مِعار بَوْرْتِنِيَّة لتحديد العمق
55 vernier	وَرْتِنِيَّة
56 straightedge	مِسْطَرَة تقويم
57 square	زَاوِيَة قائمة، كوس
58 breast drill	مِقْطاب صدري
59 twist bit (twist drill)	مِقْطاب التوائي
60 screw tap (tap)	ذَكَر لولبية
61 halves of a screw die	نصفا قالب اللولبية
62 screwdriver	مفك
63 scraper (<i>also</i> : pointed triangle scraper)	مِكْشَطَة (أيضاً مِكْشَطَة مثلثة مستدقة الطرف)
64 centre (<i>Am. center</i>) punch	سُنْبُك تعليم المركز
65 round punch	سُنْبُك دائري المقطع
66 flat-nose pliers	زردية مسطحة الفكين
67 detachable-jaw cut nippers	قَرَأْضَة ذات فك قابل للفصل
68 gas pliers	زردية موانسِر الغاز
69 pincers	كَمَاشَة

141 Gas Welder

1 gas cylinder manifold	مِجْمَع أسْطُوَانات الغاز
2 acetylene cylinder	أَسْطُوَانَة الأستيلين
3 oxygen cylinder	أَسْطُوَانَة الأوكسجين
4 high-pressure mano-	مانومتر الضغط العالي

عامل اللحام بالغاز

مِجْمَع أسْطُوَانات الغاز
أَسْطُوَانَة الأستيلين
أَسْطُوَانَة الأوكسجين
مانومتر الضغط العالي

meter	مَنْظَم الضغط، صِمَام
5 pressure-reducing valve (reducing valve, pressure regulator)	مَنْظَم الضغط المنخفض
6 low-pressure manometer	مانومتر الضغط المنخفض
7 stop valve	مِحْبَس
8 hydraulic back-pressure valve for low-pressure installations	صِمَام هيدرولي للضغط الخلفي للتركيبات منخفضة الضغط
9 gas hose	خَرْطُوم الغاز
10 oxygen hose	خَرْطُوم الأوكسجين
11 welding torch (blow-pipe)	مِشْعل/جِمالج للحام
12 welding rod (filler rod)	سِيع اللحام، سِيع إضافة
13 welding bench	طاولة اللحام
14 grating	حاجز شبيك
15 scrap box	صَنْبُوق القراضة/الخراطة
16 bench covering of chamotte slabs	غِطاء الطاولة المصنوع من أُرُوح الشاموت
17 water tank	خَزَان ماء
18 welding paste (flux)	مِجْجُون اللحام (مُساعد صهر)
19 welding torch (blow-pipe) with cutting attachment and guide tractor	مِشْعل/جِمالج للحام المزود بقَم القطع وِجَرَار دليلي
20 workpiece	قطعة الشغل
21 oxygen cylinder	أَسْطُوَانَة الأوكسجين
22 acetylene cylinder	أَسْطُوَانَة الأستيلين
23 cylinder trolley	تروولي الأَسْطُوَانات
24 welding goggles	نظارات واقية من بهر اللحام
25 chipping hammer	مِطْرَقَة جذ/تاجين
26 wire brush	قَرَشَة سلكية
27 torch lighter (blowpipe lighter)	ولاعة الجِمالج/المِشْعل
28 welding torch (blow-pipe)	مِشْعل/جِمالج للحام
29 oxygen control	مَنْظَم دفق الأوكسجين
30 oxygen connection	وَصْلَة الأوكسجين
31 gas connection (acetylene connection)	وَصْلَة الغاز (وَصْلَة الأستيلين)
32 gas control (acetylene control)	مَنْظَم دفق الغاز
33 welding nozzle	فَوْرْمَة اللحام
34 cutting machine	مَأْكِيَة القطع
35 circular template	طَبْعة/ضبيعة دائرية
36 universal cutting machine	مَأْكِيَة قطع عامة
37 tracing head	رأس تتبع الطَبْعة/الضبيعة
38 cutting nozzle	رأس القطع

142 Arc Welder

1 welding transformer	مُحَوِّل اللحام القَوْسِي
2 arc welder	مُحَوِّل اللحام القَوْسِي
3 arc welding helmet	خوذة عامل اللحام القَوْسِي
4 flip-up window	نافذة تفتح لأعلى
5 shoulder guard	واقِي الكتفين

6 protective sleeve	كَم وِاقِي
7 electrode case	غِلاف الألكترود
8 three-fingered welding glove	قَفَّاز لِحَام ذو ثلاثة أصابع
9 electrode holder	حَامِل الألكترود
10 electrode	اللكترود
11 leather apron	مِريَة جلدية
12 shin guard	وقاء الساق
13 welding table with fume extraction equipment	طاولة اللِحَام ومعدات طرد الأَدْخنة
14 table top	سَطْح الطاولة
15 movable extractor duct	مِجْرَى جِهَاز الطرد المتحرك
16 extractor support	حَامِل جِهَاز الطرد
17 chipping hammer	مِطْرَقَة الرابيش، مِطْرَقَة الجِذ/التاجين
18 wire brush	قَرَشَة سلك
19 welding lead	سلك اللحام
20 electrode holder	حَامِل الألكترود
21 welding bench	طاولة اللِحَام
22 spot welding	لِحَام البقعة
23 spot welding electrode holder	حَامِل الكُتْرود لِحَام البقعة
24 electrode arm	ذراع الألكترود
25 power supply (lead)	مُوسِل التيار الكهربِي (سلك توصيل)
26 electrode-pressure cylinder	أَسْطُوَانَة ضغط الألكترود
27 welding transformer	مُحَوِّل اللحام
28 workpiece	قطعة الشغل
29 foot-operated spot welder	جِهَاز لِحَام بقعة يتم تشغيله بالقدم
30 welder electrode arms	ذراعَا الكُتْرود جِهَاز اللِحَام
31 foot pedal for welding pressure adjustment	دَوَاسَة القدم الخاصة بتعديل ضغط اللحام
32 five-fingered welding glove	قَفَّاز لِحَام ذو خمسة أصابع
33 inert-gas torch for inert-gas welding (gas-shielded arc welding)	مِشْعل/جِمالج الغاز الخامل للحام في محيط من الغاز الخامل
34 inert-gas (shielding-gas) supply	مُضَرِّد إمداد الغاز الخامل
35 work clamp (earthing clamp)	مِلْزَمَة/قائمة الشغل
36 fillet gauge (<i>Am. gage</i>) [for measuring throat thickness]	مِقياس اللَحْمَة الزَاوِيَّة [لمِياس ثخانة العنق الفعليّة للحمّة زاوية مقعرة]
37 micrometer	ميكرومتر
38 measuring arm	ذراع المِقياس
39 arc welding helmet	خوذة اللِحَام القَوْسِي
40 filter lens	عدسة ترشيح
41 small turntable	صِيبِيَّة دَوَارة صغيرة

143 Sections, Bolts and Machine Parts	القطع والمسامير وأجزاء المَأْكِيَة
[material: steel, brass, aluminium (<i>Am. aluminum</i>),	[المادة: سَلْب ونحاس والْمِنِيوم وبلاستيك، الخ.

plastics, etc.; in the following, steel was chosen as an example]	وفيما يلي اخترنا الصلب كمثال]
1 angle iron (angle)	حديد مَرَوِيّ
2 leg (flange)	شَفَّة ، فلانشة
3-7 steel girders	كمرات الصلب
3 T-iron (tee-iron)	حديد تائي
4 vertical leg	شَفَّة رأسيّة
5 flange	شَفَّة ، فلانشة
6 H-girder (H-beam)	كَمَر على شكل حرف H
7 E-channel (channel iron)	قضيب ذو مقطع بائني
8 round bar	قضيب مستدير
9 square iron (<i>Am.</i> square stock)	حديد مربع المَقَطع
10 flat bar	قضيب مسطح
11 strip steel	صَلب شريطي
12 iron wire	سلك حديدي
13-50 screws and bolts	المبراغي والمسامير
13 hexagonal-head bolt	مِسمار مُلوَّب ذو رأس سداسي الشكل
14 head	رأس
15 shank	ساق
16 thread	حَزْ اللَوْب
17 washer	صامولة
18 hexagonal nut	صامولة مُسدّسة
19 split pin	دبوس خابوري
20 rounded end	طرف مستدير
21 width of head (of flats)	عرض الرأس (الجوانب المسطحة)
22 stud	الجويط (بُرغِي مُلوَّب عديم الرأس مُلوَّب الطرفين عادة)
23 point (end)	طَرَف مستدق
24 castle nut (castellated nut)	صامولة بُرجية
25 hole for the split pin	ثقب الدبوس الخابوري
26 cross-head screw, a sheet-metal screw (self-tapping screw)	بُرغِي صليبي الرأس، بُرغِي ألواح معدنية
27 hexagonal socket head screw	بُرغِي مجوّف ذو رأس سداسي
28 countersunk-head bolt	مِسمار مُلوَّب برأس مَحْوَش
29 catch	ماسك
30 locknut (locking nut)	صامولة رَاق أو إحكام
31 bolt (pin)	وَدّ المِسمار
32 collar-head bolt	مِسمار مُلوَّب ذو رأس طَوّقي
33 set collar (integral collar)	طَوّق المِسمار
34 spring washer (washer)	وَرْدَة / حَلْقَة نابضية
35 round nut, an adjusting nut	صامولة أُسطوانيّة، صامولة ضبط
36 cheese-head screw, a slotted screw	مِسمار مُلوَّب ذو رأس أُسطوانيّ، مِسمار مُلوَّب مَحْدود
37 tapered pin	دبوس خابوري مستدق
38 screw slot (screw slit,	شق رأس المِسمار المُلوَّب

screw groove)	مِسمار مربع الرأس
39 square-head bolt	دبوس مَحْدود، دبوس أُسطوانيّ
40 grooved pin, a cylindrical pin	مِسمار مُلوَّب ذو رأس تائي
41 T-head bolt	صامولة مِجَنحة
42 wing nut (fly nut, butterfly nut)	مِسمار مُشَوِّك (للتثبيت)
43 rag bolt	أَشْوَاك
44 barb	مِسمار بريعي للخشب
45 wood screw	رأس مَحْوَش
46 countersunk head	حزوز مِسمار حُتَب بريعي
47 wood screw thread	مِسمار ناخز
48 grub screw	شق المِسمار
49 pin slot (pin slit, pin groove)	طَرَف مستدير
50 round end	مِسمار (مِسمار إِبْرَة)
51 nail (wire nail)	رأس ساق
52 head	طَرَف مستدق
53 shank	مِسمار برأس مسطح
54 point	المُبرِشَة (بُرِشَة متراكبة)
55 roofing nail	مِسمار برشام
56 riveting (lap riveting)	رأس القالب، رأس البرشام
57 set head (swage head, die head), a rivet head	رأس المِسمار المُبرِشَة
58 rivet shank	ساق مِسمار المُبرِشَة
59 closing head	رأس المُبرِشَة، ذيل البرشام
60 pitch of rivets	خطوة مسامير المُبرِشَة (المسافة بين برشام وآخر)
61 shaft	عمود دوران
62 chamfer (bevel)	شعلية، حد مائل، شطف
63 journal	مرتكز العمود، مقعدة
64 neck	عنق، رقبة
65 seat	قاعدة، مسقر القاعدة
66 keyway	مَجزى الخابور
67 conical seat (cone)	قاعدة مخروطية (مخروط)
68 thread	لَوْب ، حزوز
69 ball bearing, an antifriction bearing	مَحْمَل الكريات (مَحْمَل مقاوم للاحتكاك)
70 steel ball (ball)	كُرَيَة من الصَلب
71 outer race	حَلْقَة مَدْرَجَة خارجية
72 inner race	حَلْقَة مَدْرَجَة داخلية
73-74 keys	خابوران
73 sunk key (feather)	خابور غاطس (خابور ريشي الشكل)
74 gib (gib-headed key)	خابور بذقن جنبية
75-76 needle roller bearing	مَجزى إسبيطيات إبري
75 needle cage	قفص إبري
76 needle	إِبْرَة
77 castle nut (castellated nut)	صامولة بُرجية
78 split pin	وَدّ خابوري
79 casing	غلاف
80 casing cover	غطاء للتغليف
81 grease nipple (lubricating nipple)	حَكْمَة التشحيم

82-96 gear wheels, cog wheels	التروس، العجلات المَسْنُقة
82 stepped gear wheel	تُرْس مدرج
83 cog (tooth)	سِن التُرْس
84 space between teeth	مسافة بين الأسنان
85 keyway (key seat, key slot)	مَجزى خابوري
86 bore	جَوْف
87 herringbone gear wheel	تُرْس لَوّبي مزدوج
88 spoke (arm)	بَرْمَق
89 helical gearing (helical spur wheel)	تُرْس لَوّبي
90 sprocket	مُسَنّات التُرْس ، مضرسة
91 bevel gear wheel (bevel wheel)	تُرْس مخروطي
92-93 spiral toothing	التسنيين الحلزوني
92 pinion	تُرْس بِنُون/صغير
93 crown wheel	تُرْس رئيسي
94-96 epicyclic gear (planetary gear)	نظام التروس التداويري
94 planet wheels	تُرْس كوكبية الدَوّارن
95 internal gear	تُرْس داخلي
96 sun wheel (sun gear)	تُرْس شمسي
97-107 absorption dynamometer	دينامومتر امتصاصي
97 shoe brake (check brake, block brake)	فرملة حداثية
98 brake pulley	بَكْرَة الفِرامل/المِكْبِج
99 brake shaft (brake axle)	عمود الفِرامل/المِكْبِج
100 brake block (brake shoe)	لَعْمَة الفِرامل/المِكْبِج
101 pull rod	ذراع الجذب
102 brake magnet	المغناطيس الرافع للفِرامل
103 brake weight	وَزْن الفِرامل
104 band brake	مِكْبِج طَوّقي
105 brake band	طَوّق الفِرامل/المِكْبِج
106 brake lining	بطانة الفِرامل/المِكْبِج
107 adjusting screw, for even application of the brake	بُرغِي الضبط لتشغيل الفِرامل/المِكْبِج بشكل منتظم
144 Coal Mine	مَنجَم الفحم
1-51 coal mine (colliery, pit)	منجم الفحم
1 pithead gear (headgear)	أجهزة قُوّة المَنجَم
2 winding engine house	بيت مرَفّاع المَنجَم
3 pithead frame (head frame)	تَمشِيبة قُوّة المَنجَم
4 pithead building	مِيتَى قُوّة المَنجَم
5 processing plant	مَعْمَل التصنيع
6 sawmill	مَنشَرَة
7-11 coking plant	وحدة تكويك
7 battery of coke ovens	بطارية من أفران التكويك
8 larry car (larry, charging car)	شاحنة مسطحة
9 coking coal tower	بُرْج فَمَح التكويك
10 coke-quenching tower	برج إطفاء التكويك
11 coke-quenching car	عربة إطفاء الكوك
12 gasometer	مَسْتَوْدَع لَحْزَن الغاز

13 power plant (power station)	وَقْياس كميته محطة توليد الطاقة الكهربائية
14 water tower	بُرْج الماء
15 cooling tower	بُرْج التبريد
16 mine fan	مروحة تبريد المَنجَم
17 depot	مَسْتَوْدَع
18 administration building (office building, offices)	مبنى الإدارة (مكاتب إدارية)
19 tip heap (spoil heap)	رَكَام الحفر
20 cleaning plant	وحدة تنظيف
21-51 underground workings (underground mining)	أشغال جوفية (تعدين جوفي)
21 ventilation shaft	بئر التهوية (مُهَوِي)
22 fan drift	سُرْب/نفق المَرَوّحة
23 cage-winding system with cages	نظام لف الأقفاص مزود بأقفاص
24 main shaft	المُهَوِي الرئيسي
25 skip-winding system	نظام لف قواديسي
26 winding inset	قناة لف
27 staple shaft	مُهَوِي داخلي
28 spiral chute	مَجزى/سقوط حلزوني
29 gallery along seam	ممر طولي في راق فَمَح
30 lateral	مَقَطع جانبي
31 cross-cut	مَقَطع عرضي، طريق مختصر
32 tunnelling (<i>Am.</i> tunneling) machine	مَكِينة حفر الأنفاق
33-37 longwall faces	واجهات طويلة الجدار
33 horizontal ploughed longwall face	واجهة طويلة الجدار ذات تحديد أفقي
34 horizontal cut longwall face	واجهة طويلة الجدار ذات قطع أفقي
35 vertical pneumatic pick longwall face	واجهة طويلة الجدار ذات مِهْوَاة قائمة
36 diagonal ram longwall face	واجهة طويلة الجدار ذات مَرَمَر منحدر مائل
37 goaf (gob, waste)	نفاية التعدين
38 air lock	دسام هوائي
39 transportation of men by cars	نقل العمال بالعبريات
40 belt conveying	النقل بالسايور/القشاطي
41 raw coal bunker	مَسْتَوْدَع الفحم الخام
42 charging conveyor	ناقل الشحن و التحميل
43 transportation of supplies by monorail car	نقل الإمدادات بواسطة عربة خُط أحادي السكة
44 transportation of men by monorail car	نقل العمال بواسطة عربة خُط أحادي السكة
45 transportation of supplies by mine car	نقل الإمدادات بواسطة عربة المَنجَم
46 drainage	تصريف مياه المَنجَم
47 sump (sink)	مَجْمَع الماء في قاع المَنجَم
48 capping	غطاء لمنع تسرب الغاز
49 [layer of] coal-bearing rock	[طبقة من] الصخور الحاوية للفحم
50 coal seam	راق/عرق فَمَح
51 fault	صدع

مَصْنَعُ الْحَدِيدِ وَالصَّبِّ

وَحْدَةُ الْفَرْجِ الْعَالِي،
فَرْجٍ قَائِمٍ
الْفَرْجِ الْعَالِي

السُّطْحُ الْعَالِي بِالْفَرْجِ
لِدَاخُلِ الْخَامِ وَمَسَاعِدِ
الصَّهْرِ أَوْ الْكُوكِ

نَاقِلَةٌ قَلَابَةٌ مَزْدُوجَةٌ
مَبْنِيَّةٌ الْإِلْقَامِ
قَادُوسِ اسْتِقْبَالِ
نَاقُوسِ

حُلِقَ الْفَرْجُ الْعَالِي
مَنْظُفَةٌ الصَّهْرِ، الْحِجْمَةُ
فَتْحَةٌ صَبِّ الْخَبَثِ
بُودُقَةٌ الْخَبَثِ

فَتْحَةٌ صَبِّ الْحَدِيدِ الْخَامِ
بُودُقَةُ الْحَدِيدِ الْخَامِ

أَبْتُوبُ الْهَبُوطِ
فَاصِلُ الْأَثْرِيَّةِ

مُسَخَّنٌ "كَاوْبِر"
حِجْرَةٌ الْإِحْتِرَاقِ الْخَارِجِي

أَبْتُوبُ اللَّفْحِ الرَّيْسِيِّ
أَبْتُوبُ الْغَازِ

أَبْتُوبُ اللَّفْحِ السَّاحِنِ
الْبُودُنَاتِ

مَصْنَعُ الصَّبِّ
فَرْجُ الْحِجْمَةِ الْمَكشُوفَةِ
لِسَيْمَنْزٍ وَمَارْتِنٍ

بُودُقَةُ الْحَدِيدِ الْخَامِ
سَجْرِيُّ الصَّبِّ
فَرْجٌ ثَابِتٌ

مِجْمَرَةٌ، مَوْقِدٌ
آلِيَّةُ السَّاحِنِ، شَاحِنَةٌ
صُنْفُوقُ شَحْنِ الْحَدِيدِ
الْخَرْدَةِ

أَبْتُوبُ الْغَازِ
حِجْرَةٌ مَسْتَرِجِ الْغَازِ
أَبْتُوبُ التَّغْذِيَةِ بِالْهَوَاءِ

حِجْرَةٌ مَسْتَرِجِ الْهَوَاءِ
بُودُقَةُ صَبِّ الصَّبِّ [من
أَسْفَلٍ] مَزْدُودَةٌ بِجِيْبِسِ

قَائِلٌ صَبِّ الْكُوكِ (الصَّبِيَّةُ)
كَلْبَةٌ مَصْنُوعِيَّةٌ مِنَ الْفُولَادِ
مَاصِيَةٌ صَبِّ خَامِ الْحَدِيدِ

حِمْصُ الصَّبِّ
مُجْرِي صَبِّ الْمَعْدِنِ
سَيْسَلَةُ مِنَ الْقَوَائِلِ

قَائِلٌ

مَمْرٌ ضَيْقٌ

147 Iron and Steel Works

1-20 blast furnace plant

1 blast furnace, a shaft furnace

2 furnace incline (lift) for ore and flux or coke

3 skip hoist

4 charging platform

5 receiving hopper

6 bell

7 blast furnace shaft

8 smelting section

9 slag escape

10 slag ladle

11 pig iron (crude iron, iron) runoff

12 pig iron (crude iron, iron) ladle

13 downtake

14 dust catcher, a dust-collecting machine

15 hot-blast stove

16 external combustion chamber

17 blast main

18 gas pipe

19 hot-blast pipe

20 tuyère

مِبْنَاءُ شَحْنِ نَاقِلَاتِ النُّقْطِ

الحَفْرُ الْبَحْرِيُّ
جِهَازُ الحَفْرِ (حَفَارَةٌ الزَّيْتِ)

مَنْصَعَةُ الحَفْرِ
مَحْطَةٌ تَوْلِيدِ الطَّاقَةِ
مُؤَاسِرِ عَادِمِ مَوْلِدِ العِطَاقَةِ
مِرْقَاعُ دَوَّارٍ

مَبْنِيَّةٌ (حِمْص) مُؤَاسِرِ الحَفْرِ
مُؤَاسِرِ عَادِمِ التَّوْرِيْبِ
مَحْزَنُ المَوَادِّ
سَلْحُ هَبُوطِ الهَلِيكُوبْتَرِ

مَصْعِدٌ
فَرْارَةٌ غَازِ وَزَيْتِ الْإِنْتِاجِ

فَرَارَاتُ اخْتِبَارِ الزَّيْتِ
وَالْغَازِ

مَبْنِيَّةٌ شَطِطُ العِطَارِيِّ
بَرْجُ الحَفْرِ
خَزَانُ رَقُودِ الدِيْزَلِ

مَبْنِيَّ المَكَاتِبِ
خَزَانَاتُ الْأَسْمَنْتِ
خَزَانُ مَاءِ الشَّرْبِ

خَزَانُ المَاءِ المَالِحِ
خَزَانَاتُ الرُّقُودِ النِّفَاثِ
قَوَارِبُ النِّجَاجَةِ
بُئْرُ المَصْعَدِ

خَزَانُ الهَوَاءِ المَضْعُوطِ
مَحْطَةُ الضَّخِّ
ضَاصِغٌ هَوَائِيٌّ

بُئْرُ المَصْعَدِ
خَزَانُ الهَوَاءِ المَضْعُوطِ

مَحْطَةُ الضَّخِّ
ضَاصِغٌ هَوَائِيٌّ
مَعْمَلٌ تَحْلِيَّةِ مِيَاهِ الْبَحْرِ

مَرْشِحَاتُ الدَاخِلِ الْخَاصَّةِ
بُودُقُودِ الدِيْزَلِ
مَبْرِدُ الْغَازِ
لُوحَةٌ تَحْكُمُ الْفَرَارَاتِ

دَوَّرَاتُ مِيَاهِ (مَرَاحِيضِ) وَرَشَّةٍ
مَصْبِيَّةٌ الْكَاشِطَةُ [تَسْتَعْمَدُ فِي تَنْظِيْفِ حِطِّ أَنْابِيْبِ الزَّيْتِ]

غُرْفَةُ التَّحْكُمِ وَالمَرَاقِبَةِ وَحَدَّاتٌ سَكِيْنَةٌ

مَبْمَحَّاتٌ سَكِيْنَةٌ عَالِيَةِ الضَّغْطِ

السُّطْحُ السِّفْلِي
السُّطْحُ الْأَوْسَطُ
السُّطْحُ العُلْوِي (السُّطْحُ الرَّيْسِيِّ)

التَّرَكِيْبَاتُ الدُّنْيَا لِجِهَازِ الحَفْرِ
مُتَوَسِّطُ ارْتِفَاعِ سَلْحِ الْبَحْرِ

74 tanker terminal

146 Offshore Drilling
1-39 drilling rig (oil rig)

1-37 drilling platform

1 power station

2 generator exhausts

3 revolving crane (pedestal crane)

4 piperack

5 turbine exhausts

6 materials store

7 helicopter deck (helicopter deck, heliport)

8 elevator

9 production oil and gas separator

10 test oil and gas separators (test separators)

11 emergency flare stack

12 derrick

13 diesel tank

14 office building

15 cement storage tanks

16 drinking water tank

17 salt water tank

18 jet fuel tanks

19 lifeboats

20 elevator shaft

21 compressed-air reservoir

22 pumping station

23 air compressor

24 air lock

25 seawater desalination plant

26 inlet filters for diesel fuel

27 gas cooler

28 control panel for the separators

29 toilets (lavatories)

30 workshop

31 pig trap [the 'pig' is used to clean the oil pipeline]

32 control room

33 accommodation modules (accommodation)

34 high-pressure cementing pumps

35 lower deck

36 middle deck

37 top deck (main deck)

38 substructure

39 mean sea level

تَصْنِيعُ الزَّيْتِ الْخَامِ

[رَسْمُ تَحْطِيْبِي] قَرْنِ الزَّيْتِ
بَرْجُ تَجْزِئَةِ ذُو أَحْوَاشِ

غَازَاتُ عُلْوِيَّةٌ، قَطَافَةٌ نَظْمِيَّةٌ
نَوَاجِجُ تَقْطِيْرِ خَفِيْفَةٍ

نَوَاجِجُ تَقْطِيْرِ ثَقِيْلَةٍ

بِقَرْوَلِ
مَرْكَبُ الْغَازِ وَالمَزِيْتِ
فَضَائِلَةُ
مَكْتَفٍ (مَبْرَدِ)

ضَاصِغٌ
مَعْمَلُ نَزْعِ الكَبْرِيْتِ

المُهَيَّبُ الكِيْمَاوِي

وَحْدَةٌ تَكْسِيْرٍ بِالْحَفْرِ

بَرْجُ التَّقْطِيْرِ
فِصْلُ الشَّعْمِ

وَحْدَةٌ تَقْطِيْرِ خَوَائِيَّةِ
قَوَارِبِ الزَّيْتِ
غَازُ الرُّقُودِ (التَّدْفِيْنَةِ)

غَازٌ بَتْرُولِيٌّ سَالٍ (غَازِ سَائِلِ)

بَنْزِيْنِ عَامِي

بَنْزِيْنِ مِمْتَازِ
زَيْتِ الدِيْزَلِ
وَقُودِ الطَّيْرَانِ

زَيْتٌ وَقُودٌ خَفِيْفٌ
زَيْتٌ وَقُودٌ ثَقِيْلٌ
بَارَافِيْنِ (كِيْرُوسِيْنِ)

زَيْتِ المَحَاوِرِ
زَيْتِ التَّرْلِيْقِ
زَيْتِ الاِسْطِرَاقَاتِ

بِيْتُوْمِيْنِ
مَصْفَاةُ الزَّيْتِ
حِطُّ أَنْابِيْبِ الزَّيْتِ

مَعَامِلُ التَّقْطِيْرِ
مَصْفَاةُ زَيْتِ التَّرْلِيْقِ
مَعْمَلُ نَزْعِ الكَبْرِيْتِ

مَعْمَلُ فِصْلِ الْغَازِ
مَعْمَلُ تَكْسِيْرِ بِالْحَفْرِ
مُهَيَّبُ كِيْمَاوِي بِالْحَفْرِ

صَهْرِيْبِيَّةٌ تَخْزِيْنِ
خَزَانُ كُرُوِي

36-64 processing of crude oil [diagram]

36 oil furnace (pipe still)

37 fractionating column (distillation column) with trays

38 top gases (tops)

39 light distillation products

40 heavy distillation products

41 petroleum

42 gas oil component

43 residue

44 condenser (cooler)

45 compressor

46 desulphurizing (desulphurization, Am. desulfurizing, desulfurization) plant

47 reformer (hydroformer, platformer)

48 catalytic cracker (cat cracker)

49 distillation column

50 de-waxing (wax separation)

51 vacuum equipment

52-64 oil products

52 fuel gas

53 liquefied petroleum gas (liquid gas)

54 regular grade petrol (Am. gasoline)

55 super grade petrol (Am. gasoline)

56 diesel oil

57 aviation fuel

58 light fuel oil

59 heavy fuel oil

60 paraffin (paraffin oil, kerosene)

61 spindle oil

62 lubricating oil

63 cylinder oil

64 bitumen

65-74 oil refinery

65 pipeline (oil pipeline)

66 distillation plants

67 lubricating oil refinery

68 desulphurizing (desulphurization, Am. desulfurizing, desulfurization) plant

69 gas-separating plant

70 catalytic cracker plant

71 catalytic reformer

72 storage tank

73 spherical tank

145 Mineral Oil (Oil, Petroleum)

1-21 oil drilling

1 drilling rig

2 substructure

3 crown safety platform

4 crown blocks

5 working platform, an intermediate platform

6 drill pipes

7 drilling cable (drilling line)

8 travelling (Am. traveling) block

9 hook

10 [rotary] swivel

11 hoist

12 engine

13 standpipe and rotary hose

14 kelly

15 rotary table

16 slush pump (mud pump)

17 well

18 casing

19 drilling pipe

20 tubing

21 drilling bit; kinds: fish-tail (blade) bit, rock (Am. roller) bit, core bit

22-27 oil (crude oil) production

22 pumping unit (pump)

23 plunger

24 tubing

25 sucker rods (pumping rods)

26 stuffing box

27 polish (polished) rod

28-35 treatment of crude oil [diagram]

28 gas separator

29 gas pipe (gas outlet)

30 wet oil tank (wash tank)

31 water heater

32 water and brine separator

33 salt water pipe (salt water outlet)

34 oil tank

35 trunk pipeline for oil [to the refinery or transport by tanker lorry (Am. tank truck), oil tanker or pipeline]

الرَّيْتُ المَعْدِنِي (النَّفْطُ، البِترُول) الحَفْرُ بَحْرًا عِنَّا الرَّيْتِ جِهَازُ الحَفْرِ التَّرَكِيْبَاتُ الدُّنْيَا لِجِهَازِ الحَفْرِ
مَبْنَعَةٌ أَمَانٌ تَاجِيَّةٌ بَكَرَاتٌ تَاجِيَّةٌ مَبْنَعَةٌ بَرْجِ الحَفْرِ
أَنْابِيْبُ الحَفْرِ كَيْبِلُ الحَفْرِ
بَكْرَةٌ مَتَحْرِكَةٌ
خُطَّافٌ
رَأْسُ مَلْفٍ [دَوَّارٍ]
أَجْهَزَةُ الرَّفْعِ
مُحَرِّكٌ
أَبْتُوبُ تَوَازُنِ وَخَرْطُومِ رَحْوِيٍّ
عَمُودٌ حَفْرٍ مُضْلَعٌ، عَمُودٌ كَيْلِيٌّ
طَبْلِيَّةُ الحَفْرِ الرَّحْوِيّ مِبْنَعَةٌ الطِّينِ الرَّحْوِيّ
بُئْرٌ
أَبْتُوبُ تَغْلِيْفِ
أَبْتُوبُ حَفْرِ
أَنْابِيْبُ إِنتِاجِ
لَقْمَةٌ الحَفْرِ: أَنْواعُهَا: لَقْمَةٌ بَشْفَرَتِيْنِ، لَقْمَةٌ ذَاتُ ثَلَاثَةِ دَلَّافِيْنِ سَسَنَةٍ، لَقْمَةُ التَّقْوِيْرِ
إِنْتِاجُ الزَّيْتِ الْخَامِ
وَحْدَةٌ الصَّخِّ غَاطِطٌ
أَنْابِيْبُ إِنتِاجِ
قَضِيْبَانُ مَاصِعٌ/ضَخٌّ
صَنْدُوقٌ حَشْوِيٌّ
قَضِيْبٌ مَصْفُوقٌ
مَعَالِجَةُ الزَّيْتِ الْخَامِ [رَسْمُ تَحْطِيْبِي]
فَاصِلُ الْغَازِ/فَرَارَاتُ الْغَازِ
أَبْتُوبُ خُرُوجِ الْغَازِ
خَزَانُ شُحْلِ خَارِجِي
سَخَّانُ مِيَاهِ
جِهَازُ فِصْلِ المَاءِ وَالمَلْحِ
أَبْتُوبُ خُرُوجِ المَاءِ المَالِحِ
خَزَانُ الزَّيْتِ
حِطُّ أَنْابِيْبِ رَيْسِي لِنَقْلِ الزَّيْتِ [إِلَى المَصْفَاةِ أَوْ لِلنَّقْلِ بِوَاسِطَةِ عَرِيْبَاتِ صَهْرِيْبِيَّةٍ أَوْ نَاقِلَاتِ نَظْمِيَّةٍ أَوْ حِطِّ أَنْابِيْبِ]

39 discharging chute	مَجْرَى تصريف	2 blast main (blast inlet, blast pipe)	أَنْبُوب اللفح الرئيسي	40 grit guard	وقاء الرواسب	stock)	
40 pig	حديد خام	3 tapping spout	فِتْحَة صَبِّ المعدن المنصهر	41 revolving table	حَصِيرَة دَوَّارَة	3 reduction drive lever	رَبِّاعَة الدَّوَّارَة
41 travelling (Am. traveling) crane	مِرْقَاع متحرك	4 spyhole	فِتْحَة مراقبة	42 casting	مَصْنُوبَة	4 lever for normal and coarse threads	رَبِّاعَة الدَّوَّارَة العاديَة
42 top-pouring pig iron (crude iron, iron) ladle	بُودَقَة صَبِّ علوي للخام	5 tilting-type [hot-metal] receiver	مَسْتَقْبِل [المعدن الساخن] من الطراز القلاب	43 fettler	جَلاخَة رُوثِيَة	5 speed change lever	رَبِّاعَة السَّرعَة
43 pouring ladle lip	حافة / شفة بُوْدَقَة الصَّبِّ	6 mobile drum-type ladle	بُودَقَة متقلِّبة من النوع الرَبِّاعِي	44 pneumatic grinder	أُرْضِيل رُوثِي	6 leadscrew reverse-gear lever	رَبِّاعَة عكس حركة لولب عمود السحب
44 tilting device (tipping device, Am. dumping device)	آليَة إمالة البُودَقَة	7 melter	عَامِل المَصْهَر	46-75 rolling mill	مَآكِينَة الدَلْفَعَة	7 change-gear box	مَسَدُون مَرُوس تنديل السَّرعَة
45-50 oxygen-blowing converter (L-D converter, Linz-Donawitz converter)	مُحَوِّل نَفْخ أكسجيني (مُحَوِّل إل-دي)	8 founder (caster)	عَامِل المَصْهَر	47 soaking pit	فَرْز غاطس	8 feed gearbox (Norton tumbler gear)	مَسَدُون تروس التَغذِيَة (البِيَة الرَبِّاعِي الدَّوَّار لعمودتون)
45 conical converter top	قمة المُحَوِّل المخروطية	9 tap bar (tapping bar)	عَامِل المَصْبَك	48 ingot	مِرْقَاع الفَرْز الغاطس	9 levers for changing the feed and thread pitch	مَسَدُون تروس التَغذِيَة (البِيَة الرَبِّاعِي الدَّوَّار لعمودتون)
46 mantle	ترتِيبة إمالة المُحَوِّل	10 bott stick (Am. bot stick)	قَضِيْب نَزْع السَّادَة (عن قُوْمَة الصَّبِّ)	49 ingot tipper	كَلْبَة معدنيَة مَصْنُوبَة	10 feed gear lever (tumbler lever)	أُرْزَع آليَة التَغذِيَة (ذِرَاع حركة الرَبِّاعِي الدَّوَّار)
47 solid converter bottom	قاع صَبِّ المُحَوِّل	11 molten iron	عصا ذات سدادة طَيِينَة لسد فِتْحَة الصَّبِّ	50 roller table	كُرْسِي قلاب للكتل	11 switch lever for right or left hand action of main spindle	ذِرَاع آليَة التَغذِيَة (ذِرَاع حركة الرَبِّاعِي الدَّوَّار)
48 fireproof lining (refractory lining)	بَطَانَة مَقَاوِمَة للحريق (بَطَانَة حراريَة)	12 slag spout	خديِد منصهر	51 workpiece	حَصِيرَة مَآكِينَة دَلْفَعَة الكتل		ذِرَاع الضبط الخاصَة بالتشغيل اليَمِينِي أو اليساري لعمود الدَّوَّار الرئيسي
49 oxygen lance	مَاسورة الأوكسجين	13 casting team	فُوْمَة خروج الخبيث	52 bloom shears	مَجْمُوعَة من دَوَّارِيْن		قاعدة المَخْرَطَة
50 tapping hole (tap hole)	فِتْحَة صَبِّ المعدن المنصهر	14 hand shank	فَرِيْق عَامِلِي الصَّبِّ	53 two-high mill	مَآكِينَة دَلْفَعَة ثنائيَة		عَجَلَة لُؤْب عمود الجر الخاصَة بحركة السرج المستعرضة
51-54 Siemens electric low-shaft furnace	فُورْن سِيْمَنْز الكهربي اللافح القصير	15 double handle (crutch)	ذِرَاع مزدوج	54-55 set of rolls (set of rollers)	مَجْمُوعَة من دَوَّارِيْن		ذِرَاع عكس حركة الرَبِّاعِي الدَّوَّار
51 feed	مَتَمِّنَة الشحن	16 carrying bar	قَضِيْب حمل	55 lower roll (lower roller)	الدَّالْفِين العلوي		لُؤْب التَغذِيَة
52 electrodes [arranged in a circle]	الكترودات [في نسق دائري]	17 skimmer rod	قَضِيْب الكاسِطَة	56-60 roll stand	الدَّالْفِين السفلي		وقاء تَرْس المَخْرَطَة
53 bustle pipe	مَاسورة الهواء اللافح	18 closed moulding (Am. moulding) box	النصف العلوي لقلاب السباكة (فردة الغطاء)	56 base plate	هَيْكَل مَآكِينَة الدَلْفَعَة		ذِرَاع الحركة الطوليَة والمستعرضة
54 runout	حَصِيرَة خروج المعدن المنصهر	19 upper frame (cope)	النصف السفلي لقلاب السباكة (فردة القاع)	57 housing (frame)	قاعدة الهَيْكَل		ذِرَاع تَرْس دودي متساقط لتعشيق أليّات التَغذِيَة
55-69 Thomas converter (basic Bessemer converter)	مُحَوِّل توماس (مُحَوِّل بسمر الأساسي)	20 lower frame (drag)	مَجْرَى صَبِّ المعدن المنصهر	58 coupling spindle	هَيْكَل المَآكِينَة		ذِرَاع تعشيق الصامولة النصفية للوُؤْب عمود السحب
55 charging position for molten pig iron	مَوْضِع شحن خام الخديِد المنصهر	21 runner (runner gate, down-gate)	مصعد	59 groove	عمود دَوَّار		ذِرَاع عكس حركة الرَبِّاعِي الدَّوَّار
56 charging position for lime	مَوْضِع شحن الجير	22 riser (riser gate)	بُودَقَة/مِغْرَفَة يدويَة	60 roll bearing	كُرْسِي الدَّالْفِين		لُؤْب التَغذِيَة
57 blow position	مَوْضِع اللفح	23 hand ladle	الصَّبِّ المتواصل	61-65 adjusting equipment	مُدَّة الضَّبط		وقاء تَرْس المَخْرَطَة
58 discharging position	مَوْضِع التصريف	24-29 continuous casting	أرْضِيَة صَبِّ غاطِسة	61 chock	كُرْسِي دَعامة		ذِرَاع الحركة الطوليَة والمستعرضة
59 tilting device (tipping device, Am. dumping device)	جِهَاز إمالة	24 sinking pouring floor	خام حديد متجمد	62 main screw	الفتيل الرئيسي		ذِرَاع تَرْس دودي متساقط لتعشيق أليّات التَغذِيَة
60 crane-operated ladle	بُودَقَة تعمل بمِرْقَاع	25 solidifying pig	طُور التجمد	63 gear	موتور (مُحْرَك)		ذِرَاع تعشيق الصامولة النصفية للوُؤْب عمود السحب
61 auxiliary crane hoist	وَش رَفِّع إضائِي	26 solid stage	طُور السويْلَة	64 motor	مُوَشْر الضَّبط التقريبي		ذِرَاع الحركة الطوليَة والمستعرضة
62 lime bunker	مَخْرَن الجير	27 liquid stage	نظام التبريد بالمياه	65 indicator for rough and fine adjustment	والضبط الدقيق		ذِرَاع تَرْس دودي متساقط لتعشيق أليّات التَغذِيَة
63 downpipe	أَنْبُوب الهبوط	28 water-cooling system	جدار قالب الصَّبِّ	66-75 continuous rolling mill train for the manufacture of strip [diagram]	مُدْرَج مَآكِينَة دَلْفَعَة مستمرة لصناعة الشرائح [رَسْم تَخْطِيْطِي]		ذِرَاع تعشيق الصامولة النصفية للوُؤْب عمود السحب
64 tipping car (Am. dump truck)	شاحنة قلابية	29 mould (Am. mold) wall	وَرْتَمَة قوالب الصَّبِّ	66-68 processing of semi-finished product	تَصْنِيع نَتَاج نصف تَنْشِيْب		عمود دوران المِخْرَطَة
65 scrap iron feed	شحن الحديد الخردة	30-37 moulding (Am. moulding) department (moulding shop)	عَامِل الصَّبِّ	66 semi-finished product	نَتَاج نصف تَنْشِيْب		حَامِل قَلَم القَطْع
66 control desk	لَوْحَة التَحْكَم	30 moulder (Am. molder)	مِدْكَ يَعمل بِالهَوَاءِ	67 gas cutting installation	وَحْدَة القَطْع الغازي		حَامِل قَلَم انزلاقي
67 converter chimney	مَخْرَن المُحَوِّل	31 pneumatic rammer	المضغوط	68 stack of finished steel sheets	رِصَمَة من ألواح المَلْب		مُتَرْقِّطَة مستعرضة
68 blast main	أَنْبُوب اللفح الرئيسي	32 hand rammer	مِدْكَ يدوي	69 continuous reheating furnaces	كاملة التَنْشِيْب		مُتَرْقِّطَة الفَرْشَة
69 wind box	صَنْدُوق الهواء	33 open moulding (Am. moulding) box	صَنْدُوق صَبِّ مَفْتُوح	70 blooming train	أفْران إِعادة التسخين المستمرة		أَنْبُوب إِبداد المَبْرَد
148 Iron Foundry and Rolling Mill	مَسْبِك الحديد و مَآكِينَة الدَلْفَعَة	34 pattern	قالب صَبِّ	71 finishing train	حَصِيرَة مَآكِينَة دَلْفَعَة الكتل		مركز الغراب المتحرك
1-45 iron foundry	مَسْبِك الحديد	35 moulding (Am. molding) sand	رَمَل قالب الصَّبِّ	72 coiler	حَصِيرَة التَنْشِيْب		رَبِّاعِي (برَمِيل الغَرَاب المتحرك)
1-12 melting plant	مَعْمَل الصهر	36 core	قلب المَسْتَوِك	73 stock of coils for sale	مَآكِينَة لَف		قائمة برَمِيل الغَرَاب المتحرك
1 cupola furnace (cup-ola), a melting furnace	فُورْن الدَسْت (كوبولا)، فُورْن الصهر	37 core print	طَبِيعَة قلب المَسْتَوِك	74 5 mm shearing train	مَجْمُوعَة طَبَقَات للبيع		فَرْشَة المِخْرَطَة
		38-45 cleaning shop (fettling shop)	وَرْتَمَة التَوَضِيْب	75 10 mm shearing train	حَصِيرَة قَص 5 م م		لُؤْب عمود السحب
		38 steel grit or sand delivery pipe	أَنْبُوب تصريف رُوساب الصَّبِّ أو الرَمَل		حَصِيرَة قَص 10 م م		عمود التَغذِيَة
		39 rotary-table shot-blasting machine	مَآكِينَة سَعْب بالمساحيق الحاكمة مَزُودَة بحَصِيرَة دَوَّارَة	149 Machine Tools I			
				1 centre (Am. center) lathe	أَلَات الوَرْتِش (I)		
				2 headstock with gear control (geared head-	مَخْرَطَة ذَنْبِيَة		
					غَرَاب ثابت مَجهر بمسبات		

رأس سهم
خط القطاع
القطاع أ-ب
سطح مائل
خط المركز
لوحة بيانات الملكية
بيانات فنية
مسطرة
مسطرة مثثة
شبلونة مسح
خرطوش حبر الرّسم
مقلّعة أقلام الرّسم الأثويّية
مجموعة من أقلام الرّسم الأثويّية
هيجرومتر
غطاء موضح عليه حجم سن القلم
مبحة على شكل قلم
رصاص
مبحة
سكين مسو
نمّل سكين المسو
قلم رصاص ذو قبايض
رصاص القلم
مبحة زجاجية
ألياف زجاجية
قلم تسطير
وصلة تقاطعية
قرص دليلي
فِرْجَار ذو ملحقات تبادلية
رأس الفِرْجَار
وصلة الطرف الأيبري
وصلة طرف قلم الرصاص
إيبرة، دبوس
ذراع استقالة
وصلة قلم التسطير
فِرْجَار مبضي
مكبس
وصلة قلم التسطير
وصلة القلم الرصاص
مدوّاة حبر الرّسم
فِرْجَار ذو نابض
مفصل حلقة النابض
وصلة الرّسم الدقيق
المحمولة على نابض لرّسم الأقفاس
إبرة قائمة الزاوية
وحدة حبر أثويّية
مسطرة حروف الاستسل
لوح الدوائر

رأس سهم
خط القطاع
القطاع أ-ب
سطح مائل
خط المركز
لوحة بيانات الملكية
بيانات فنية
مسطرة
مسطرة مثثة
شبلونة مسح
خرطوش حبر الرّسم
مقلّعة أقلام الرّسم الأثويّية
مجموعة من أقلام الرّسم الأثويّية
هيجرومتر
غطاء موضح عليه حجم سن القلم
مبحة على شكل قلم
رصاص
مبحة
سكين مسو
نمّل سكين المسو
قلم رصاص ذو قبايض
رصاص القلم
مبحة زجاجية
ألياف زجاجية
قلم تسطير
وصلة تقاطعية
قرص دليلي
فِرْجَار ذو ملحقات تبادلية
رأس الفِرْجَار
وصلة الطرف الأيبري
وصلة طرف قلم الرصاص
إيبرة، دبوس
ذراع استقالة
وصلة قلم التسطير
فِرْجَار مبضي
مكبس
وصلة قلم التسطير
وصلة القلم الرصاص
مدوّاة حبر الرّسم
فِرْجَار ذو نابض
مفصل حلقة النابض
وصلة الرّسم الدقيق
المحمولة على نابض لرّسم الأقفاس
إبرة قائمة الزاوية
وحدة حبر أثويّية
مسطرة حروف الاستسل
لوح الدوائر

عمود دوران التفرير الأفقي
دعامة طرّيقية لتثبيت عمود دوران التفرير الأفقي
ذکر لولبة مكبّنة
روبوت مفصلي، روبوت صناعي (إنسان آلي)
لوح القاعدة
عمود دوّار (محور قاعدة دوّار)
مفصل الكتف
العضد
مفصل مرفقي
ساعد أثويّي
مفصل رسغي
شفّة تركيب القابض
القابض
أصابع
روبوت قائم (روبوت ذو محور طولي، روبوت مستقيم)
روبوت باي (روبوت قنطري)
مكّتب الرّسم الهندسيّ
لوحة الرّسم
جهاز رسم ذو حركة متوازية
مقبض الضبط والتعديل
رأس الرّسم (زاوية قائمة قابلة للتعديل)
ألية ضبط لوحة الرّسم
طاولة الرّسم
زاوية قائمة (مثلث)
مثلث
مسطرة قائمة
رّسم مطوي (ملفوف)
رّسم تحصيلي
جدول زمني
حامل ورق الرّسم
لفه ورق
نمّل قطع الورق
رّسم فني (تصميم)
منظر أمامي
منظر جانبي
تمثيل تحصيلي
سطح لا يصنع ألباً
سطح يصنع ألباً
سطح يتم تشطيبه تشطيباً فاحراً
حافة مرئية
حافة غير مرئية
خط البعد

مدرّج القياس
كشبيان مدرج
إطار
عمود دوران
قَدَمَة ذات ورنية
مسطرة وصلة معيار العمق
مقياس ورنّي
فكّان خارجيان
فكّان داخليان
معيار عمق ورنّي
آلات الورش (2)
جلاخة عامة
غراب ثابت
مترّقة رأس العجلة (لتركيب قرص التجلخ)
عجلة تجليخ
غراب متحرك
فرشة الجلاخة
صينية الجلاخة
مقسطة غرّبة ذات قاشمين
محرّك الإدارة
قائم
صينية المقسطة
مترّقة عرضية (مجرّي أفقي)
مربط القلم
بشّار معادن
نبيلة ربط
نمّل المشّار
إطار المشّار
ماكينة تقب نصف قطرية (ماكينة التّوجّيق دف)
قاعدة (لوح القاعدة)
ككّلة ارتكاز قطعة الشغل
عمود
محرّك رفع
عمود دوران المنقب
ذراع الكتيّفة
ماكينة تفرير عامة
صينية ماكينة التفرير
إدارة تغذية الصينية
ذراع ضبط سرعة عمود الدوران
صندوق التحكم (وحدة التحكم)
عمود دوران التفرير
الرّاسّي
رأس الإدارة الرّاسية

63 measuring scale
64 graduated thimble
65 frame
66 spindle (screwed spindle)
67 vernier calliper (caliper) gauge (Am. gage)
68 depth gauge (Am. gage) attachment rule
69 vernier scale
70 outside jaws
71 inside jaws
72 vernier depth gauge (Am. gage)
150 Machine Tools II
1 universal grinding machine
2 headstock
3 wheelhead slide
4 grinding wheel
5 tailstock
6 grinding machine bed
7 grinding machine table
8 two-column planing machine (two-column planer)
9 drive motor, a direct current motor
10 column
11 planer table
12 cross slide (rail)
13 tool box
14 hacksaw
15 clamping device
16 saw blade
17 saw frame
18 radial (radial-arm) drilling machine
19 bed (base plate)
20 block for workpiece
21 pillar
22 lifting motor
23 drill spindle
24 arm
25 universal milling machine
26 milling machine table
27 table feed drive
28 switch lever for spindle rotation speed
29 control box (control unit)
30 vertical milling spindle
31 vertical drive head

عمود عكس الحركة اليمنى واليسرى والتعشيق والفصل
طرّف ذو أربعة فكوك
فك قابض
طرّف ذو ثلاثة فكوك
مخرّطة برّوجية
مترّقة مستعرضة
برج
ماسك أقلام قطع موثلف
مترّقة علوية
عجلة نجّية
صينية المبرّد لتجميع المحلول المبرّد والخراطة
أقلام المخرّطة
حامل قلم قطع خاص بأسنان القلم القابلة لل ضبط
سن قطع قابل لل ضبط مصنوع من كبريد سمّنت أو سيراميك أكسيدي
أشكال أسنان من السيراميك الأكسيدي القابلة لل ضبط
عدة مخرّطة ذات حافة قطع من الكريبد السمّنت
ساق القلم
سن قطع كبريدي سمّنت ملحوم بالنحاس
قلم تسوية الأوجه الداخلية للشغل الزاوي
قلم مخرّطة للأغراض العامة
عدة قطع، قلم قطعية
حامل (كلّية المخرّطة)
مدور (كلّية المخرّطة)
آلات القياس
محدد قياس سداي القياس القلوب
طرّف قياس سماحي
طرّف قياس لا سماحي
قَدَمَة آلة قياس ذات فكين
الجانب السماحي
الجانب اللاسماحي
ميكرومتر

34 reverse shaft for right and left hand motion and engaging and disengaging
35 four-jaw chuck (four-jaw independent chuck)
36 gripping jaw
37 three-jaw chuck (three-jaw self-centring, Am. self-centering, chuck)
38 turret lathe
39 cross slide
40 turret
41 combination toolholder (multiple turning head)
42 top slide
43 star wheel
44 coolant tray for collecting coolant and swarf
45-53 lathe tools
45 tool bit holder (clamp tip tool) for adjustable cutting tips
46 adjustable cutting tip (clamp tip) of cemented carbide or oxide ceramic
47 shapes of adjustable oxide ceramic tips
48 lathe tool with cemented carbide cutting edge
49 tool shank
50 brazed cemented carbide cutting tip (cutting edge)
51 internal facing tool (boring tool) for corner work
52 general-purpose lathe tool
53 parting (parting-off) tool
54 lathe carrier
55 driving (driver) plate
56-72 measuring instruments
56 plug gauge (Am. gage)
57 'GO' gauging (Am. gaging) member (end)
58 'NOT GO' gauging (Am. gaging) member (end)
59 calliper (caliper, snap) gauge (Am. gage)
60 'GO' side
61 'NOT GO' side
62 micrometer

154 Nuclear Energy

- 1 fast-breeder reactor (fast breeder) [diagram]
- 2 primary circuit (primary loop, primary sodium system)
- 3 reactor
- 4 fuel rods (fuel pins)
- 5 primary sodium pump
- 6 heat exchanger
- 7 secondary circuit (secondary loop, secondary sodium system)
- 8 secondary sodium pump
- 9 steam generator
- 10 cooling water flow circuit
- 11 steam line
- 12 feedwater line
- 13 feed pump
- 14 steam turbine
- 15 generator
- 16 transmission line
- 17 condenser
- 18 cooling water
- 19 nuclear reactor, a pressurized-water reactor (nuclear power plant, atomic power plant)
- 20 concrete shield (reactor building)
- 21 steel containment (steel shell) with air extraction vent
- 22 reactor pressure vessel
- 23 control rod drive
- 24 control rods
- 25 primary coolant pump
- 26 steam generator
- 27 fuel-handling hoists
- 28 fuel storage
- 29 coolant flow passage
- 30 feedwater line
- 31 prime steam line
- 32 manway
- 33 turbogenerator set
- 34 turbogenerator
- 35 condenser
- 36 service building
- 37 exhaust gas stack
- 38 polar crane
- 39 cooling tower, a dry cooling tower
- 40 pressurized-water

- الطاقة النووية**
مفاعل مولد سريع [رسم تحطيطي]
الدائرة الأولية (نظام الصوديوم الأولي)
الفاعل
قضبان الوقود
مضخة الصوديوم الأولية (نظام الصوديوم الثانوي)
مبادل حراري الدائرة الثانوية
مضخة الصوديوم الثانوية
مولد بخاري
دائرة دفع ماء التبريد
خط البخار
خط مياه التغذية
مضخة التغذية
توربين بخاري
مولد (كهربائي)
خط النقل
مكثف
ماء التبريد
المفاعل النووي، مفاعل يعمل بالماء المضغوط (وحدة توليد طاقة نووية)
مبنى خرساني (مبنى المفاعل)
غلاف من الصلب ذو فتحة لاستخلاص الهواء
وعاء المفاعل الضغطي
إدارة ذراع التحكم
أذرع التحكم
مضخة المبرد الأولية
مولد بخاري
مواقع مناولة الوقود
خزان الوقود
مجري تدفق المبرد
خط مياه التغذية
خط البخار الرئيسي
مضرب
جهاز مولد توربيني
مولد توربيني
مكثف
مبنى الخدمة
ماسورة غاز العادم
مرافق قطبي
برج التبريد، برج جاف
نظام الماء المضغوط

- 23 high-pressure cylinder
- 24 medium-pressure cylinder
- 25 low-pressure cylinder
- 26 three-phase generator (generator)
- 27 hydrogen cooler
- 28 leakage steam path
- 29 jet nozzle
- 30 turbine monitoring panel with measuring instruments
- 31 automatic voltage regulator
- 32 synchro
- 33 cable box
- 34 conductor
- 35 feed-through terminal (feed-through insulator)
- 36 core
- 37 casing
- 38 filling compound (filler)
- 39 lead sheath
- 40 lead-in tube
- 41 cable
- 42 high voltage cable, for three-phase current
- 43 conductor
- 44 metallic paper (metallized paper)
- 45 tracer (tracer element)
- 46 varnished-cambric tape
- 47 lead sheath
- 48 asphalted paper
- 49 jute serving
- 50 steel tape or steel wire armour (Am. armor)
- 51-62 air-blast circuit breaker, a circuit breaker
- 51 compressed-air tank
- 52 control valve (main operating valve)
- 53 compressed-air inlet
- 54 support insulator, a hollow porcelain supporting insulator
- 55 interrupter
- 56 resistor
- 57 auxiliary contacts
- 58 current transformer
- 59 voltage transformer (potential transformer)
- 60 operating mechanism housing
- 61 arcing horn

- أسطوانات ضغط عالٍ
أسطوانات ضغط متوسط
أسطوانات ضغط منخفض
مولد ثلاثي الأطوار
مبرد هيدروجيني
مسار البخار المتسرب
مفت نفاثي
لوحة مراقبة التوربين وبها آلات قياس
منظم فولطية آلي
سنكرو
صندوق الكابل
موصل
طرف تغذية
قلب الملف
غلاف خارجي
مركب حشو
غلاف سلك التوصيل
أنبوب السلك المسحوب
كابل
كابل عالي الفولطية لتيار ثلاثي الأطوار
موصل
ورق معدني
عنصر استشفافي شريط من اللماش الناعم الرقيق مطلي بالورنيث
غلاف سلك التوصيل
ورق منسّط
غلاف مقبّر
شريط صلب أو درع معدني سلكي
قاطع دائرة باليدفج الهوائي (قاطع دائرة)
خزان هواء مضغوط
صمام التحكم (صمام التشغيل الرئيسي)
مدخل الهواء المضغوط
عازل إنسادي، عازل إنسادي أجوف من اليورسلين
قاطع التيار
مقاوم
ملاصات مساعدة
محول التيار
محول الفولطية
مبيت آلية التشغيل
قزنة إنكاء القوس

- turbogenerator unit
- 37 cross arm (traverse)
- 38 strain insulator
- 39 mobile (transportable) transformer (power transformer, transformer)
- 40 transformer tank
- 41 bogie (Am. truck)
- 42 oil conservator
- 43 primary voltage terminal (primary voltage bushing)
- 44 low-voltage terminals (low-voltage bushings)
- 45 oil-circulating pump
- 46 oil cooler
- 47 arcing horn
- 48 transport lug
- 153 Power Plant (Power Station) II
- 1-8 control room
- 1-6 control console (control desk)
- 1 control board (control panel) for the alternators
- 2 master switch
- 3 signal light
- 4 feeder panel
- 5 monitoring controls for the switching systems
- 6 controls
- 7 revertive signal panel
- 8 matrix mimic board
- 9-18 transformer
- 9 oil conservator
- 10 breather
- 11 oil gauge (Am. gage)
- 12 feed-through terminal (feed-through insulator)
- 13 on-load tap changer
- 14 yoke
- 15 primary winding (primary)
- 16 secondary winding (secondary, low-voltage winding)
- 17 core
- 18 tap (tapping)
- 19 transformer connection
- 20 star connection (star network, Y-connection)
- 21 delta connection (mesh connection)
- 22 neutral point
- 23-30 steam turbine, a
- برج صلب تشابكي
ذراع تصالبي
عازل صامد للشد (انفعالي)
محول نقال
خزان المحول
عربة نقل منخفضة
حافطة الزيت
طرف توصيل الفولطية الأولية
أطراف توصيل الفولطية المنخفضة
مضخة تدوير الزيت
مبرد الزيت
قزنة إنكاء القوس الكهربائي
وصلة الجر بسيارة
محطة توليد الطاقة (2)
غرفة التحكم
كونسول التحكم
لوحة التحكم الخاصة بمولدات التيار المتناوب
المفتاح الرئيسي
ضوء إرشادي
ضوء التغذية
مضابيط المراقبة الخاصة بأنظمة التحويل
مضابيط/مفاتيح التحكم
لوحة الإشارات المرئية
لوحة المحاكاة الأم المحول
حافطة الزيت
فتحة تنقيس
مقياس الزيت
طرف تغذية
مقبّر التفرغ
مقرن اللغاف المعغظ اللغيفة الابتدائية
اللغيفة الثانوية (لغيفة منخفضة الفولطية)
قلب الملف
مأخذ تفرغ، نقطة التفرغ
توصيلة المحول
توصيلة نجمية
توصيلة دلتا/مثلثية
نقطة التعادل/الغطالة التوربين البخاري

- 71 ellipse template
- 152 Power Plant (I) (Power Station)
- 1-28 steam-generating station, an electric power plant
- 1-21 boiler house
- 1 coal conveyor
- 2 coal bunker
- 3 travelling-grate (Am. travelling-grate) stoker
- 4 coal mill
- 5 steam boiler, a water-tube boiler (radiant-type boiler)
- 6 burners
- 7 water pipes
- 8 ash pit (clinker pit)
- 9 superheater
- 10 water preheater
- 11 air preheater
- 12 gas flue
- 13 electrostatic precipitator
- 14 induced-draught (Am. induced-draft) fan
- 15 chimney (smokestack)
- 16 de-aerator
- 17 feedwater tank
- 18 boiler feed pump
- 19 control room
- 20 cable tunnel
- 21 cable vault
- 22 turbine house
- 23 steam turbine with alternator
- 24 surface condenser
- 25 low-pressure preheater
- 26 high-pressure preheater (economizer)
- 27 cooling water pipe
- 28 control room
- 29-35 outdoor sub-station, a substation
- 29 busbars
- 30 power transformer, a mobile (transportable) transformer
- 31 stay poles (guy poles)
- 32 high-voltage transmission line
- 33 high-voltage conductor
- 34 air-blast circuit breaker (circuit breaker)
- 35 surge diverter (Am. lightning arrester, arrester)
- 36 overhead line support,

- لوحة الرسم الإهليلجي
محطة توليد الطاقة (1)
محطة توليد البخار، محطة طاقة كهربائية
مبنى المرجل
سير نقل الفحم
مستودع الفحم
وقاد آلي ذو مضبّعة متحركة
طاحونة الفحم
مرجل بخاري
مواقد
أنابيب الماء
حفرة الرماد
سخان فوقي
سخان ماء متقدّم
سخان هواء متقدّم
مدخنة تصريف الغاز
مرسب الكروتوستاتي
مروحة سحب مستحث
مدخنة
وعاء نزح الهواء
خزان ماء التغذية
مضخة تغذية المرجل
غرفة التحكم
نفق الكابلات
قبو الكابلات
مبيت التوربين
توربين بخاري ذو مولد للتيار المتناوب
مكثف سطحي
سخان متقدّم منخفض الضغط
سخان متقدّم عالي الضغط
ماسورة ماء التبريد
غرفة التحكم
محطة فرعية خارجية
موصلات عمومية
محول طاقة نقال
قضبان تثبيت
خط نقل (كهربائي) عالي الفولطية
موصل عالي الفولطية
قاطع الدائرة الكهربائية باليدفج الهوائي
واقية صواعق
حامل الخطوط الهوائية،

sulphide wet collector)	جهاز غسل الغاز من الأمونيا
23 ammonia scrubber (ammonia wet collector)	جهاز غسل الغاز من البنزين
24 benzene (benzol) scrubber	خزان الغاز
25 gas holder	ضاغط الغاز
26 gas compressor	ضخ البنزول بواسطة مُبرِّد ومبادل حراري
27 debenzoling by cooler and heat exchanger	ضخ كبريت غاز الضغط
28 desulphurization (<i>Am.</i> desulfurization) of pressure gas	تبريد الغاز
29 gas cooling	تجفيف الغاز
30 gas drying	عداد الغاز
31 gas meter	خزان القار الخام
32 crude tar tank	إمداد حامض الكبريتيك
33 sulphuric acid (<i>Am.</i> sulfuric acid) supply	إنتاج حامض الكبريتيك
34 production of sulphuric acid (<i>Am.</i> sulfuric acid)	إنتاج كبريتات الأمونيوم
35 production of ammonium sulphate (<i>Am.</i> ammonium sulfate)	كبريتات الأمونيوم
36 ammonium sulphate (<i>Am.</i> ammonium sulfate)	وحدة استرجاع عوادم السيلين
37 recovery plant for recovering the scrubbing agents	تصريف الماء الفائض/ المهذور
38 waste water discharge	استخلاص الفينول من ماء الغاز
39 phenol extraction from the gas water	خزان الفينول الخام
40 crude phenol tank	إنتاج البنزول الخام (البنزين الخام)
41 production of crude benzol (crude benzene)	خزان البنزول الخام (البنزين الخام)
42 crude benzol (crude benzene) tank	خزان زيت الغسيل
43 scrubbing oil tank	خط الغاز الرئيسي منخفض الضغط
44 low-pressure gas main	خط الغاز الرئيسي عالي الضغط
45 high-pressure gas main	
157 Sawmill	المششرة
1 sawmill	المششرة
2 vertical frame saw (مشتملة على مشابير جماعية) (<i>Am.</i> gang mill)	مشارة إطارية قائم
3 saw blades	أضراس المشابير
4 feed roller	درفلين الإنفام
5 guide roller	درفلين دليلي
6 fluting (grooving, grooves)	خدود طولية
7 oil pressure gauge (<i>Am.</i> gage)	مقياس ضغط الزيت
8 saw frame	إطار المشابير
9 feed indicator	مؤشر الإنفام
10 log capacity scale	مقياس سعة جذع الشجرة

41 reactor	مفاعل	41 turbine inlet for water from the sea	فتحة دخول ماء الحوض التوربين
42 primary circuit (primary loop)	الدائرة الأولى	42 wind power plant (wind generator, aero-generator)	وحدة توليد الطاقة بالرياح (مولد هوائي)
43 circulation pump (recirculation pump)	مضخة التدوير (مضخة إعادة التدوير)	43 truss tower	برج جملوني
44 heat exchanger (steam generator)	مبادل حراري (مولد بخاري)	44 guy wire	سلك شداد
45 secondary circuit (secondary loop, feed-water steam circuit)	الدائرة الثانوية (دائرة بخارية لغياة التغذية)	45 rotor	مروحة، رفاص
46 steam turbine	توربين بخاري	46 generator with variable pitch for power regulation	مولد ذو خطوة متبادلة لتنظيم الطاقة
47 generator	مولد (كهربائي)	156 Coking Plant	وحدة التوكيك
48 cooling system	نظام التبريد	1-15 coking plant	وحدة التوكيك
49 boiling water system [diagram]	نظام الماء المغلي [رسم تخطيطي]	1 dumping of coking coal	إفراغ قحم التوكيك
50 reactor	مفاعل	2 belt conveyor	سير نقال
51 steam and recirculation water flow paths	ممرات تدفق ماء إعادة التدوير والبخار	3 blending bunker	مستودع المزج
52 steam turbine	توربين بخاري	4 service bunker conveyor	سير نقل صومعة الفحم
53 generator	مولد (كهربائي)	5 service bunker	صومعة الفحم
54 circulation pump (recirculation pump)	مضخة التدوير (مضخة إعادة التدوير)	6 larry car (larry, charging car)	عربة شحن الفرن
55 coolant system (cooling with water from river)	نظام المبرِّد (تبريد بماء النهر)	7 pusher ram	آلية دفع قحم الكوك
56 radioactive waste storage in salt mine	تخزين النفايات المشعة في منجم ملح	8 battery of coke ovens	بطارية أفران الكوك
57-68 geological structure of abandoned salt mine converted for disposal of radioactive waste (nuclear waste)	التركيب الجيولوجي لمنجم ملح مهجور يستخدم في التخلص من النفايات المشعة	9 coke guide	دليل الكوك
57 Lower Keuper	كوبير سفلي	10 quenching car, with engine	عربة نقل الكوك لإطفائه
58 Upper Muschelkalk	سوشلاك (ترياس) علوي	11 quenching tower	برج إطفاء الكوك
59 Middle Muschelkalk	سوشلاك (ترياس) أوسط	12 coke loading bay (coke wharf)	رصيف تحميل الكوك
60 Lower Muschelkalk	سوشلاك (ترياس) سفلي	13 coke wharf conveyor	سير رصيف الكوك
61 Bunter downthrow	رمية سفلية	14 screening of coke and breeze	غزبة كل الفحم وتراب الفحم
62 residue of leached (lixiviated) Zechstein (Upper Permian)	فضالة "زكستين" محلحة (برمية علوية)	15 coke loading	تحميل الكوك
63 Aller rock salt	ملح صخر "البر"	16-45 coke-oven gas processing	معالجة غاز فرن الكوك
64 Leine rock salt	ملح صخر "لاين"	16 discharge (release) of gas from the coke ovens	تصريف الغاز من أفران الكوك
65 Stassfurt seam (potash salt seam, potash salt bed)	طبقة ستاسفورتية (طبقة ملح بوتاسي)	17 gas-collecting main	الخط الرئيسي لتجميع الغاز
66 Stassfurt salt	ملح ستاسفورتية	18 coal tar extraction	استخلاص قار الكوك
67 grenzanhydrite	جرزانهايدريت	19 gas cooler	مبرِّد الغاز
68 Zechstein shale	غضار، طين صفحي	20 electrostatic precipitator	جهاز ترسيب الكروستاتي
69 shaft	مِهْوَلة المنجم	21 gas extractor	فرازة الغاز
70 minehead buildings	مباني رأس المنجم	22 hydrogen sulphide (<i>Am.</i> hydrogen sulfide)	جهاز غسل الغاز من كبريتيد الهيدروجين
71 storage chamber	غرفة تخزين		
72 storage of medium-active waste in salt mine	تخزين نفايات متوسطة الإشعاعية في منجم ملح		
73 511 m level	مستوى 511 م		
74 protective screen (anti-radiation screen)	ستار واقٍ من الإشعاع		
75 lead glass window	نافذة من الزجاج		

system	نظام	76 storage chamber	غرفة تخزين
41 reactor	مفاعل	77 drum containing radioactive waste	برميل يحتوي على نفايات مشعة
42 primary circuit (primary loop)	الدائرة الأولى	78 television camera	كاميرا تلفزيونية
43 circulation pump (recirculation pump)	مضخة التدوير (مضخة إعادة التدوير)	79 charging chamber	غرفة الشحن
44 heat exchanger (steam generator)	مبادل حراري (مولد بخاري)	80 control desk (control panel)	لوحة التحكم
45 secondary circuit (secondary loop, feed-water steam circuit)	الدائرة الثانوية (دائرة بخارية لغياة التغذية)	81 upward ventilator	جهاز تهوية صاعد
46 steam turbine	توربين بخاري	82 shielded container	حاوية مبرَّدة
47 generator	مولد (كهربائي)	83 490 m level	مستوى 490 م
48 cooling system	نظام التبريد	155 Modern Sources of Energy	مصادر الطاقة الحديثة
49 boiling water system [diagram]	نظام الماء المغلي [رسم تخطيطي]	1 heat pump system	نظام المضخة الحرارية
50 reactor	مفاعل	2 source water inlet	مدخل ماء المنبع
51 steam and recirculation water flow paths	ممرات تدفق ماء إعادة التدوير والبخار	3 cooling water heat exchanger	المبادل الحراري لماء التبريد
52 steam turbine	توربين بخاري	4 compressor	ضاغط
53 generator	مولد (كهربائي)	5 natural-gas or diesel engine	محرِّك يعمل بالغاز الطبيعي أو الديزل
54 circulation pump (recirculation pump)	مضخة التدوير (مضخة إعادة التدوير)	6 evaporator	مبخِّر
55 coolant system (cooling with water from river)	نظام المبرِّد (تبريد بماء النهر)	7 pressure release valve	صمام إعتاق الضغط
56 radioactive waste storage in salt mine	تخزين النفايات المشعة في منجم ملح	8 condenser	مكثف
57-68 geological structure of abandoned salt mine converted for disposal of radioactive waste (nuclear waste)	التركيب الجيولوجي لمنجم ملح مهجور يستخدم في التخلص من النفايات المشعة	9 waste-gas heat exchanger	المبادل الحراري لغاز العادم
57 Lower Keuper	كوبير سفلي	10 flow pipe	أنبوب التدفق
58 Upper Muschelkalk	سوشلاك (ترياس) علوي	11 vent pipe	أنبوب تفتيس
59 Middle Muschelkalk	سوشلاك (ترياس) أوسط	12 chimney	مدخنة
60 Lower Muschelkalk	سوشلاك (ترياس) سفلي	13 boiler	مرجل
61 Bunter downthrow	رمية سفلية	14 fan	مروحة
62 residue of leached (lixiviated) Zechstein (Upper Permian)	فضالة "زكستين" محلحة (برمية علوية)	15 radiator	مشعاع
63 Aller rock salt	ملح صخر "البر"	16 sink	بالوعة
64 Leine rock salt	ملح صخر "لاين"	17-36 utilization of solar energy	استغلال الطاقة الشمسية
65 Stassfurt seam (potash salt seam, potash salt bed)	طبقة ستاسفورتية (طبقة ملح بوتاسي)	17 solar (solar-heated) house	مبنى شمسي (يتم تدفئته بالطاقة الشمسية)
66 Stassfurt salt	ملح ستاسفورتية	18 solar radiation (sun-light, insolation)	إشعاع شمسي
67 grenzanhydrite	جرزانهايدريت	19 collector	مجمع الإشعاع الشمسي
68 Zechstein shale	غضار، طين صفحي	20 hot reservoir (heat reservoir)	الخزان الساخن
69 shaft	مِهْوَلة المنجم	21 power supply	مصدر إمداد طاقة
70 minehead buildings	مباني رأس المنجم	22 heat pump	مضخة حرارية
71 storage chamber	غرفة تخزين	23 water outlet	مخرج الماء
72 storage of medium-active waste in salt mine	تخزين نفايات متوسطة الإشعاعية في منجم ملح	24 air supply	مصدر إمداد الهواء
73 511 m level	مستوى 511 م	25 fluc	مصرف الغازات، مدخنة
74 protective screen (anti-radiation screen)	ستار واقٍ من الإشعاع	26 hot water supply	مصدر إمداد الماء الساخن
75 lead glass window	نافذة من الزجاج	27 radiator heating	تسخين المشعاع
		28 flat plate solar collector	مجمع إشعاع شمسي مسطح الصفايح
		29 blackened receiver surface with asphalted aluminium (<i>Am.</i> aluminium) foil	سطح مستقبل مطلي باللون الأسود ذو رقاقة المونيم مسطحة
		30 steel tube	أنبوب من الصلب
		31 heat transfer fluid	سائل نقل الحرارة
		32 flat plate solar collector, containing	مجمع إشعاع شمسي مسطح الصفايح ذو خلية شمسية

places] (chimney brick)	
160 Cement Works (Cement Factory)	مصنع الأسمنت
1 raw materials (lime-stone, clay, and marl)	مواد خام (حجر جيرى وطفال وطين جيرى)
2 hammer crusher (hammer mill)	كسارة مطرقية
3 raw material store	مخزن المواد الخام
4 raw mill for simultaneously grinding and drying the raw materials with exhaust gas from the heat exchanger	طاحونة الخام لطحن وتجفيف المواد الخام في آن واحد مع غاز العادم المنبعث من المبادل الحراري
5 raw meal silos	صوامع الجيريش الخام
6 heat exchanger (cyclone heat exchanger)	مبادل حراري
7 dust collector (an electrostatic precipitator) for the heat exchanger exhaust from the raw mill	جهاز ترسيب غبار عادم المبادل الحراري الناتج عن طاحونة الخام
8 rotary kiln	قمين دوّار
9 clinker cooler	مبرد مخلفات الاحتراق
10 clinker store	مخزن مخلفات الاحتراق
11 primary air blower	نافع هوائي أولي
12 cement-grinding mill	وحدة طحن الأسمنت
13 gypsum store	مخزن الجبس (الجبص)
14 gypsum crusher	كسارة الجبس (الجبص)
15 cement silo	صومعة أسمنت
16 cement-packing plant	وحدة تعبئة الأسمنت

161 Porcelain and China Manufacture	صناعة البورسلين والصيني
1 grinding cylinder (ball mill) for the preparation of the raw material in water	طاحونة بكرات لتجهيز المواد الخام في الماء
2 sample sagger (saggar, seggar), with aperture for observing the firing process	صندوق عينات ذو ثقب لملاحظة عملية الإشتعال
3 bottle kiln (beehive kiln) [diagram]	قمين قنيني الشكل [رسم تخطيطي]
4 firing mould (Am. mold)	صندوق الإشتعال
5 tunnel kiln	قمين نفقي الشكل
6 Seger cone (pyrometric cone, Am. Orton cone) for measuring high temperatures	مخروط "زيجر" (مخروط المقياس الحراري) لقياس درجات الحرارة المرتفعة
7 de-airing pug mill (de-airing pug press), an extrusion press	خلّاط ملاط يعمل بنزّع الهواء
8 clay column	عمود الطين
9 thrower throwing a ball (bat) of clay	خزّاف، عامل تشكيل الطين
10 slug of clay	يشكل كرة طينية
11 turntable; sim.: potter's	كتلة طين
	عجلة الخزّاف، صينية

31 pick	صاقور
32 crowbar (pinch bar)	عغلة
33 fork	شوكة
34 stonemason	البّناء (بالحجارة)
35-38 stonemason's tools	أدوات البّناء بالحجارة
35 stonemason's hammer	مطرقة البّناء
36 mallet	مدقة
37 drove chisel (drove, booster, broad chisel)	أزميل عريض للثحت
38 dressing axe (Am. ax)	بلمة تهذيب
159 Brickworks (Brickyard, Brickfield)	مصنع الطوب
1 clay pit	خفرة الطين/الطفال
2 loam, an impure clay (raw clay)	طفال رملي (طين خام)
3 overburden excavator, a large-scale excavator	حفّارة الغطاء الترابي
4 narrow-gauge (Am. narrow-gage) track system	مسار سكة حديدية ضيقة
5 inclined hoist	مرفّع مائل
6 souring chambers	غرف الحامض
7 box feeder (feeder)	وحدة الإقام صندوقية
8 edge runner mill (edge mill, pan grinding mill)	رّخى ذات حجر عمودي
9 rolling plant	وحدة الدلافين
10 double-shaft trough mixer (mixer)	خلّاط ذو مجرى له عمودين (خلّاط)
11 extrusion press (brick-pressing machine)	ماكينة كبس الطوب
12 vacuum chamber	حجرة تفريغ
13 die	قالب التشكيل
14 clay column	عمود الطفال
15 cutter (brick cutter)	أداة قطع الطوب
16 unfired brick (green brick)	طوب لبني (طوب نبي)
17 drying shed	عنبر التجفيف
18 mechanical finger car (stacker truck)	عربة ترصيص الطوب
19 circular kiln (brick kiln)	قمين دائري (قمين الطوب)
20 solid brick (building brick)	قالب طوب صلب (طوب بناء)
21-22 perforated bricks and hollow blocks	قوالب طوب مقنّب وقوالب طوب مجوّف
21 perforated brick with vertical perforations	طوب مقنّب ذو ثقوب رأسية
22 hollow clay block with horizontal perforations	طوب طفتلي مجوف ذو ثقوب أفقية
23 hollow clay block with vertical perforations	طوب طفتلي مجوف ذو ثقوب رأسية
24 floor brick	طوب الأرضية
25 compact brick (radial brick, radiating brick)	طوب أشدّ (البناء المنحنيات)
26 hollow flooring block	طوب أرضية مجوف
27 paving brick	طوب الرصف
28 cellular brick [for fire-	طوب خلوي [للمدقات]

فتحة خروج الخشب	56 discharge opening
مشّار دائري مزدوج لقطع الحواف	57 twin edger (double edger)
مقياس عرض الخشب	58 breadth scale (width scale)
وقاء الارتداد	59 kick-back guard (plates)
مقياس الارتفاع	60 height scale
مقياس الإقام	61 in-feed scale
لمبات إرشادية	62 indicator lamps
طولية الإقام	63 feed table
مشّار دوّار للقطع السفلي	64 undercut swing saw
أداة تثبيت آلية ذات غطاء واق	65 automatic hold-down with protective hood
مفتاح تشغيل سفلي	66 foot switch
لوحة التوزيع	67 distribution board (panelboard)
حاجز الطول، مصدّ	68 length stop
المحجر	158 Quarry
المحجر، محجر مكتوف	1 quarry, an open-cast working
الغطاء الصخري/الترابي	2 overburden
سطح الشتل	3 working face
كومة صخور سائبة	4 loose rock pile (blasted rock)
عامل المحجر	5 quarryman (quarrier), a quarry worker
مرزبة	6 sledge hammer
إسفين	7 wedge
كتلة من الحجر	8 block of stone
حفار، نقاب	9 driller
خوذة أمان	10 safety helmet
مطرقة ثقب (مقّاب صخور)	11 hammer drill (hard-rock drill)
ثقب الحفر	12 borehole
حفارة عامة الأغراض	13 universal excavator
شاحنة كبيرة الحمولة	14 large-capacity truck
واجهة صخرية	15 rock face
مرفّع مائل	16 inclined hoist
كسارة أوليّة	17 primary crusher
وحدة تكسير الحجارة	18 stone-crushing plant
كسارة لفافة للخام	19 coarse rotary (gyratory) crusher; sim.: fine rotary (gyratory) crusher
بالمثل كسارة لفافة للخام الناعم	20 hammer crusher (impact crusher)
كسارة مطرقية/صدمية	21 vibrating screen
غزّبال هزاز	22 screenings (fine dust)
نفاية الغريلة (تراب ناعم)	23 stone chippings
نحاتة صخرية	24 crushed stone
خدر مهتمّ	25 shot firer
عامل التفجير، مشعل الملقطة	26 measuring rod
خضيب قياس	27 blasting cartridge
خراطوش متفجر	28 fuse (blasting fuse)
فيوز تفجير	29 plugging sand (stemming sand) bucket
دلو رمال حشو	30 dressed stone
حجر مشكّل	

المعدّ للثّشّر	11 auxiliary carriage
عربة مساعدة	12 carriage
عربة	13 log grips
كلايات تثبيت جذع الشجرة	14 remote control panel
لوحة التحكم عن بعد	15 carriage motor
موتور العربة	16 truck for splinters (splints)
عربة لحمل الشطابيا	17 endless log chain (Am. jack chain)
والشرائح	18 stop plate
سلسلة متواصلة لدفع جذوع الشجر	19 log-kicker arms
سيز نقال متعاكس	20 cross conveyor
ماكينة غسل	21 washer (washing machine)
سيز نقال متعاكس بسلسلة لنقل الخشب المنشور	22 cross chain conveyor for sawn timber
نضد الدلافين	23 roller table
مشّار دوّار للقطع السفلي	24 undercut swing saw
تكويم الألواح	25 piling
حامل دلفيني	26 roller trestles
مرفّع قفطري متحرك	27 gantry crane
موتور المرفّع	28 crane motor
كلايات محورية لمسك جذوع الشجر	29 pivoted log grips
خشب مستدير المقطع	30 roundwood (round timber)
كومة جذوع أشجار	31 log dump
مخزن الخشب المسوي	32 squared timber store
جذوع أشجار منشورة	33 sawn logs
ألواح خشبية ثخينة	34 planks
ألواح خشبية	35 boards (planks)
خشب مربع المقطع (مسوي)	36 squared timber
حامل الرصّة	37 stack bearer
مشّار سلسلة آلي للقطع المتعارض	38 automatic cross-cut chain saw
كلايات تثبيت جذع الشجرة	39 log grips
دفع رولر	40 chain roller
جهاز شد السلسلة	41 chain-tensioning device
ماكينة شدّ أسنان المشّار	42 saw-sharpening machine
عجلة تجليح (الأسنان المشّار)	43 grinding wheel (teeth grinder)
لسين الإقام	44 feed pawl
ذراع تعديل عمق ماكينة شدّ أسنان المشّار	45 depth adjustment for the teeth grinder
ذراع طرفّ الخلاخة	46 lifter (lever) for the grinder chuck
جهاز تثبيت نُصل المشّار	47 holding device for the saw blade
مشّار شريطي أفقي لنشر جذوع الشجر	48 horizontal bandsaw for sawing logs
آلية تعديل الارتفاع	49 height adjustment
أداة إزالة القشور	50 chip remover
عربة	51 chip extractor
نصل مشّار شريطي	52 carriage blade
مشّار كتل آلي	53 automatic blocking saw
قناة الإقام	54 feed channel
	55 feed channel

lever	تروس تغيير السرعة
29 variable change-speed gear	صندوق الأسطوانة المخروطية
30 cone drum box	أذرع إيقاف وبذاء جهاز التغذية
31 stop and start levers for the hopper	أسطوانة المناولة الخشبية
32 wooden hopper delivery roller	جهاز التغذية
33 hopper feeder	ماكينة الكرد (ماكينة تسريح)
34 carding machine (card, carding engine)	أسطوانة لاستقبال شريط الكرد
35 card can (carding can), for receiving the coiled sliver	قاعدة الأسطوانة
36 can holder	أسطوانات الضغط
37 calender rollers	شريط كرد
38 carded sliver (card sliver)	منشط الدوفر الرغاش
39 vibrating doffer comb	ذراع التشغيل
40 start-stop lever	كرسي أسطوانة التلجيج
41 grinding-roller bearing	الدوفر
42 doffer	أسطوانة
43 cylinder	منشط الحضان
44 flat clearer	الحضان
45 flats	بكر حمل الحضان
46 supporting pulleys for the flats	الملف
47 scutcher lap (carded lap)	مسند الملف
48 scutcher lap holder	محرك إدارة سنر مسطح
49 drive motor with flat belt	طارة الإدارة الرئيسية
50 main drive pulley fast-and-loose drive pulley)	رسم توضيحي لماكينة الكرد
51 principle of the card (of the carding engine)	درافيل تغذية مخدد
52 fluted feed roller	درافيل مسنن (المبشار)
53 lick-in (taker-in, lick-in roller)	الغطاء السفلي للمبشار
54 lick-in undercasing	الغطاء السفلي للأسطوانة
55 cylinder undercasing	ماكينة التمشيط
56 combing machine (comber)	صندوق تروس الإدارة
57 drive gearbox (driving gear)	لغاف معدة للتمشيط
58 laps ready for combing	أسطوانات الضغط
59 calender rollers	صندوق السحب لماكينة التمشيط
60 comber draw box	عداد
61 counter	الطرف العلوي للملفات
62 coiler top	رسم توضيحي لماكينة التمشيط
63 principle of the comber	اللفافة
64 lap	المقبض السفلي
65 bottom nipper	المقبض العلوي
66 top nipper	المنشط العلوي
67 top comb	أسطوانة التمشيط
68 combing cylinder	

wheel	دوارة	machine, ■ bottle-making machine	ماكينة صنع الزجاجات
12 filter press	مكبس ترشيح	22-37 blowing processes	عمليات نفخ الزجاج
13 filter cake	قالب ترشيح	22 blow-and-blow process	عملية تشكيل الزجاج نفخاً ومضاً
14 jiggering, with ■ profiling tool; sim.: jollyng	جهاز تثبيت القطع أثناء تشكيلها وبه أداة تشكيل الجانبية	23 introduction of the gob of molten glass	إدخال كتلة الزجاج المصهور
15 plaster mould (Am. mold) for slip casting	قالب حصن الملب المتزلق	24 first blowing	النفخ الأول
16 turntable glazing machine	ماكينة تلميع ذات حبيبة دوارة	25 suction	المص
17 porcelain painter (china painter)	رسام البورسلين (رسام الصيني)	26 transfer from the parison mould (Am. mold) to the blow mould (Am. mold)	النقل من قالب العجينة إلى قالب النفخ
18 hand-painted vase	زهريّة (مزهريّة) مرسومة يدوياً	27 reheating	إعادة التسخين
19 repairer	مصلح الأشكال المكسورة	28 blowing (suction, final shaping)	النفخ (المصن، التشكيل النهائي)
20 pallet (modelling, Am. modeling, tool)	لقدرة (سكين تشكيل)	29 delivery of the completed vessel	مناولة الإناء المكتمل
21 shards (sherds, potsherds)	شققات من الفخار (قطع خزف مكسورة)	30 press-and-blow process	عملية تشكيل الزجاج كبساً ومضاً
162 Glass Production	إنتاج الزجاج	31 introduction of the gob of molten glass	إدخال كتلة الزجاج المصهور
1-20 sheet glass production (flat glass production)	إنتاج الواح الزجاج (الزجاج المسطح)	32 plunger	كبّاس
1 glass furnace (tank furnace) for the Fourcault process [diagram]	فرن الزجاج الخاص بطريقة "فوركولت" [رسم تخطيطي]	33 pressing	الكبس
2 filling end, for feeding in the batch (frit)	طرف الإلقاء للتغذية بالعجينة الزجاجية (مسخوق مزجج)	34 transfer from the press mould (Am. mold) to the blow mould (Am. mold)	النقل من قالب العجينة إلى قالب النفخ
3 melting bath	مغطس الانصهار	35 reheating	إعادة التسخين
4 refining bath (fining bath)	مغطس تنقية	36 blowing (suction, final shaping)	النفخ (المصن، التشكيل النهائي)
5 working baths (working area)	مغاطس الشغل (منطقة الشغل)	37 delivery of the completed vessel	مناولة الإناء المكتمل
6 burners	مواقد	38-47 glassmaking (glass-blowing, glass-blowing by hand, glass forming)	صنع الزجاج (نفخ الزجاج يدوياً، تشكيل الزجاج) نافع الزجاج
7 drawing machines	ماكينات السحب	38 glassmaker (glass-blower)	صانع الزجاج
8 Fourcault glass-drawing machine	ماكينة "فوركولت" لسحب الزجاج	39 blowing iron	أنبوب النفخ
9 slot	حز خفيق	40 gob	كغلة
10 glass ribbon (ribbon of glass, sheet of glass) being drawn upwards	لوح زجاجي يسحب لأعلى	41 hand-blown goblet	كغلة صغيرة منفوخة يدوياً
11 rollers (drawing rolls)	أسطوانات السحب	42 clappers for shaping the base (foot) of the goblet	مقسطة لتشكيل قاعدة الكغلة
12 float glass process	عملية تصنيع الزجاج الطافية	43 trimming tool	أداة تشذيب
13 batch (frit) feeder (funnel)	ملمع عجينة الزجاج	44 tongs	كلاب، ماسك
14 melting bath	مغطس الانصهار	45 glassmaker's chair (gaffer's chair)	معدن نافع الزجاج
15 cooling tank	خزان التبريد	46 covered glasshouse pot	وعاء زجاجي مغطى
16 float bath in a protective inert-gas atmosphere	مغطس بطوف في محيط من الغاز الخامل	47 mould (Am. mold), into which the parison is blown	قالب المصب الذي تنفخ فيه العجينة
17 molten tin	قصدير مصهور	48-55 production of glass fibre (Am. glass fiber)	إنتاج الألياف الزجاجية
18 annealing lehr	"لير" (فرن التذنين المستمر)	48 continuous filament process	عملية إنتاج الألياف الزجاجية المستمرة
19 automatic cutter	قاطع آلي	49 glass furnace	فرن الزجاج
20 stacking machines	ماكينة رص	50 bushing containing molten glass	غلاف يحتوي على زجاج مصهور

51 bushing tips	طرف الغلاف
52 glass filaments	ألياف زجاجية
53 sizing	معايرة
54 strand (thread)	خيط
55 spool	بكرة
56-58 glass fibre (Am. glass fiber) products	منتجات الألياف الزجاجية
56 glass yarn (glass thread)	غزل زجاجي، خيط زجاجي
57 sleeved glass yarn (glass thread)	خيط زجاجي متروم
58 glass wool	الصوف الزجاجي
163 Cotton Spinning I	غزل القطن (I)
1-13 supply of cotton	إمداد القطن
1 ripe cotton boll	بنتة قطن يابسة
2 full cop (cop wound with weft yarn)	كب كامل
3 compressed cotton bale	بالة قطن مضغوطة
4 jute wrapping	غلاف من النيل
5 steel band	شريط معدني
6 identification mark of the bale	علامة تعريف البالة
7 bale opener (bale breaker)	ماكينة تقطيع البالات
8 cotton-feeding brattice	حصيرة التغذية بالقطن
9 cotton feed	صندوق التغذية بالقطن
10 dust extraction fan	مروحة شفط الغبار
11 duct to the dust-collecting chamber	أنبوية توصيل الغبار إلى غرفة الأتربة
12 drive motor	محرك الإدارة
13 conveyor brattice	حصيرة ناقلة
14 double scutcher (machine with two scutchers)	ماكينة الملفات المزدوجة
15 lap cradle	مسند الملف
16 rack head	رأس الحامل
17 starting handle	يد التشغيل
18 handwheel, for raising and lowering the rack head	طارة رفع وخفض رأس الحامل
19 movable lap-turner	محول الملف المتحرك
20 calender rollers	أسطوانات الضغط
21 cover for the perforated cylinders	غطاء قفص الأسطوانات المتقبعة (غطاء القفص العلوي)
22 dust escape flue (dust discharge flue)	أنبوية تصريف الغبار
23 drive motors (beater drive motors)	محركات الإدارة
24 beater driving shaft	عمود إدارة المضرب
25 three-blade beater (Kirschner beater)	مضرب ذو ثلاث ريش
26 grid [for impurities to drop]	شبكة صمغيات [لفصل الشوائب]
27 pedal roller (pedal cylinder)	أسطوانة دواسة
28 control lever for the pedal roller, ■ pedal	ذراع التحكم الخاصة بأسطوانة الدواسة

40 indigo dying and sizing machine	ماكينة الصباغة باللون الأزرق والتبويض
41 take-off stand	حامل مأخذ القدرة
42 warp beam	أسطوانات السدء
43 warp	وعاء الترطيب
44 wetting trough	دولفين الغمر
45 immersion roller	دولفين الغمر
46 squeeze roller (mangle)	دولفين الغمر
47 dye liquor padding trough	وعاء سائل الصبغة
48 air oxidation passage	مجرى هواء الأكسدة
49 washing trough	وعاء الغسل
50 drying cylinders for pre-drying	أسطوانات التجفيف المبدئي
51 tension compensator (tension equalizer)	موازن الشد
52 sizing machine	ماكينة التبويض
53 drying cylinders	أسطوانات التجفيف
54 for cotton: stenter; for wool: tenter	ماكينة الشد وضبط العرض
55 beaming machine	ماكينة التسوية المباشرة
56 sized warp beam	أسطوانة سداء مبيوثة
57 rollers	أسطوانات
166 Weaving II	الفنسيج (2)
1 weaving machine (automatic loom)	ماكينة النسيج (نول أوتوماتيكي)
2 pick counter (tachometer)	عداد الحداقات
3 shaft (heald shaft, heald frame) guide	دليل الذراع
4 shafts (heald shafts, heald frames)	الذراع
5 rotary battery for weft replenishment	مستودع مواسير اللحمة
6 sley (sley) cap	غطاء الذف
7 weft pin	ماسورة اللحمة
8 starting and stopping handle	ذراع البدء والإيقاف
9 shuttle box, with shuttles	درج الموايك وبداخله الموايك
10 reed	المنظ
11 selvedge (selvage)	برؤسل القماش
12 cloth (woven fabric)	القماش المنسوج
13 temple (cloth temple)	التميت
14 electric weft feeler	حساس اللحمة الكهربائي
15 flywheel	الحداقة
16 breast beam board	مسند الصدر
17 picking stick (pick stick)	ذراع القذف
18 electric motor	محرك كهربائي
19 cloth take-up motion	جهاز طي للقماش
20 cloth roller (fabric roller)	مطواة القماش
21 can for empty pirms	صندوق مواسير اللحمة الفارغة
22 lug strap, for moving the picking stick	سيز سحب لتحريك ذراع القذف
23 fuse box	صندوق مضمهرات/ فيوزات

69 plain part of the cylinder	جزء أمس بأسطوانة التمشيط
70 needed part of the cylinder	أسنان المسط الإبرية
71 detaching rollers	بالأسطوانة
72 carded and combed sliver	دراफल الفصل الحامة المنمشة
164 Cotton Spinning II	غزل القطن (2)
1 draw frame	ماكينة السحب
2 gearbox with built-in motor	صندوق التروس المتصل بالمحرك المبيت
3 sliver cans	أسطوانات الشريط
4 broken thread detector roller	أسطوانة كشف انقطاع الخيط
5 doubling of the slivers	تجميع الشرايط
6 stopping handle	يد الإيقاف
7 draw frame cover	غطاء ماكينة السحب
8 indicator lamps (signal lights)	مصابيح إرشادية
9 simple four-roller draw frame (diagram)	رسم توضيحي لماكينة سحب ذات أربع أسطوانات الأسطوانات السفلية
10 bottom rollers (lower rollers), fluted steel rollers	أسطوانات صلب محددة
11 top rollers (upper rollers) covered with synthetic rubber	أسطوانات علوية مغطاة بمادة لدنة
12 doubled slivers before drafting	الشرايط المجدعة قبل سحبها
13 thin sliver after drafting	شريط رفيع بعد سحبه
14 high-draft system (high-draft draw frame) [diagram]	نظام اللقي العالي (رسم تخطيطي)
15 feeding-in of the sliver	تغذية الشريط
16 leather apron (composition apron)	إزار جلدي
17 guide bar	قضيب دليلي
18 light top roller (guide roller)	أسطوانة علوية دليلية
19 high-draft speed frame (fly frame, slubbing frame)	ماكينة البرم الابتدائي
20 sliver cans	أسطوانات الشريط
21 feeding of the slivers to the drafting rollers	الشريط المغذي لأسطوانات السحب
22 drafting rollers with top clearers	أسطوانات السحب ذات المنتلفات العلوية
23 roving bobbins	بكر (بوبيينات) البرم الابتدائي
24 fly frame operator (operative)	ملاحظ ماكينة البرم
25 flyer	الفانوس
26 frame end plate	غطاء جانب الماكينة
27 intermediate yarn-forming frame	ماكينة البرم المتوسط
28 bobbin creel (creel)	حامل البكر
29 roving emerging from the drafting rollers	الغزل المنبروم الخارج من أسطوانات السحب
30 lifter rail (separating rail)	قضيب رافع (العربية)
31 spindle drive	إدارة المرذن
32 stopping handle	يد الإيقاف
33 gearbox, with built-on motor	صندوق التروس المتصل بالمحرك
34 ring frame (ring spinning frame)	ماكينة الغزل الحلقي
35 three-phase motor	محرک ثلاثي الأطوار
36 motor base plate (bed-lifting)	لوحة قاعدة المحرك
37 lifting bolt [for motor removal]	حلقة لرفع المحرك
38 control gear for spindle speed	منظم للمرذن ذي السرعة المتغيرة
39 gearbox	غراب الرأس (صندوق التروس)
40 change wheels for varying the spindle speed [to change the yarn count]	تروس نقل لتغيير نمز الخيوط
41 full creel	حامل البكر
42 shafts and levers for rising and lowering the ring rail	أعمدة وروافع لرفع وخفض العربة
43 spindles with separators	مرادين مع فواصل
44 suction box connected to the front roller underclearers	صندوق شفط متصل بالمنتلفات السفلية للأسطوانة الأمامية
45 standard ring spindle	مرذن غزل حلقي تغطي عمود المرذن
46 spindle shaft	عمود المرذن
47 roller bearing	كرسي تحميل
48 wharve (pulley)	صرة المرذن
49 spindle catch	ماسك المرذن
50 spindle rail	قضيب المرذن
51 ring and traveller (Am. traveler)	الطقة والدليفة (في ماكينة الغزل الحلقي)
52 top of the ring tube (of the bobbin)	الطرف العلوي لبكرة الغزل الحلقي
53 yarn (thread)	خيط الغزل
54 ring fitted into the ring rail	الطقة المثبتة في العربة
55 traveller (Am. traveler)	الدليفة
56 yarn wound onto the bobbin	خيط الغزل ملفوفاً على البكرة
57 doubling frame	ماكينة نقل الخيط
58 creel, with cross-wound cheeses	حامل بكر به مجموعة من البكر الملفوف لفاً متقاطعاً
59 delivery rollers	دراफल مناولة
60 bobbins of doubled yarn	بكر الخيط المقتول
165 Weaving I	الفنسيج (1)
1-57 processes preparatory to weaving	العمليات التحضيرية للفنسيج
1 cone-winding frame	ماكينة لف المخروط
2 travelling (Am. travelling) blower	نافخ محرك
3 guide rail, for the	قضيب دليلي للنافخ المحرك
travelling (Am. traveling) blower	نافخ محرك
4 blowing assembly	تجميع النفاخ
5 blower aperture	فتحة النفاخ
6 superstructure for the blower rail	الحامل العلوي لقضيب النافخ
7 full-cone indicator	مبين المخروط الملفوف لفاً حلزونياً
8 cross-wound cone	حساس مخروط بحامل البكر
9 cone creel	حوامل المخاريط
10 grooved cylinder	أسطوانة بها تجاويف حلزونية (دليل الخيط) شقوقية متعرجة لمرور الخيط
11 guiding slot for cross-winding the threads	اللوحة الجانبية للماكينة ويدخله المحرك
12 side frame, housing the motor	منظم الشد والمحص
13 tension and slub-catching device	جانب الماكينة مع مرشح
14 off-end framing with filter	عبوة التغذية (بكرة غزل حلقي أو ماسورة غزل العربية)
15 yarn package, a ring tube or mule cop	صندوق عبوات التغذية ذراع البدء والإيقاف
16 yarn package container	دليل لتسهيل مرور الخيط
17 starting and stopping lever	وسيلة إيقاف أوتوماتيكية لإيقاف الماكينة عند انقطاع الخيط
18 self-threading guide	المحص
19 broken thread stop motion	منظم شد الخيط
20 thread clearer	ماكينة التسوية
21 weighting disc (disk) for tensioning the thread	مروحة
22 warping machine	مخاريط بحامل البكر
23 fan	حامل البكر
24 cross-wound cone	منظ الأشتيك
25 creel	إطار الماكينة
26 adjustable comb	عداد طول الخيط
27 warping machine frame	أسطوانة السداء
28 yarn length recorder	طارة أسطوانة السداء
29 warp beam	قضيب وقائي
30 beam flange	طبور الإدارة
31 guard rail	إدارة يسير
32 driving drum (driving cylinder)	محرک
33 belt drive	دواسة لبدء حركة طبور الإدارة
34 motor	الإدارة
35 release for starting the driving drum	برغي ضبط المنظ
36 screw for adjusting the comb setting	مسامير ساقطة لإيقاف الماكينة عند انقطاع الخيط
37 drop pins, for stopping the machine when a thread breaks	قضيب دليلي
38 guide bar	أسطوانات المسامير
39 drop pin rollers	الساقطة

(bottom fulling roller)	لَوْح السحب
7 draft board	ماكينة غَسْل الألياف الصوفية
8 open-width scouring machine for finer fabrics	القماش الخارج من الماكينة
9 fabric being drawn off the machine	صندوق لتروس الإدارة
10 drive gearbox	ماسورة دخول الماء
11 water inlet pipe	درفيل السحب
12 drawing-in roller	قضيب فرد القماش
13 scroll-opening roller	عمارة بدولية بالطرد المركزي لنزع السوائل من القماش
14 pendulum-type hydro-extractor (centrifuge), for extracting liquors from the fabric	قاعدة الماكينة
15 machine base	غطاء فوق التعليق
16 casing over suspension	الوعاء الخارجي وبداخله القفص الموار
17 outer casing containing rotating cage (rotating basket)	غطاء قفص العمارة
18 hydro-extractor (centrifuge) lid	وسيلة إيقاف للأمان
19 stop-motion device (stopping device)	وسيلة بدء التشغيل وفرملة آلية
20 automatic starting and braking device	ماكينة الشد وضبط العرَض
21 for cotton: stenter; for wool: tenter	القماش المُكَلَّ
22 air-dry fabric	منصة تشغيل
23 operator's (operative's) platform	دلائل تغذية القماش للمقاييس والندبابيس
24 feeding of fabric by guides onto stenter (tenter) pins or clips	لُوحَات تحكم كهربائية
25 electric control panel	تغذية إضافية للسماح بالانكماش في اتجاه السداء
26 initial overfeed to produce shrink-resistant fabric when dried	ترمومتر
27 thermometer	غرفة التخميف
28 drying section	مُخْرَج الهواء
29 air outlet	وسيلة لتطبيق القماش
30 plaiter (fabric-plaiting device)	ماكينة الكسفرة
31 wire-roller fabric-raising machine for producing raised or nap surface	صندوق تروس الإدارة
32 drive gearbox	قماش غير مكسفر
33 unraised cloth	درفيل مغطاة بالأسلاك
34 wire-covered rollers	وسيلة لتطبيق القماش
35 plaiter (cuttling device)	قماش مكسفر
36 raised fabric	طبلة
37 plaiting-down platform	ماكينة الكي الدوارة
38 rotary press (calendering machine), for press finishing	القماش
39 fabric	زر الإدارة ومضابط الحركة
40 control buttons and control wheels	

يدويًا	الخيط
36 thread (yarn)	دليل إرجاع الخيط
37 return spring	نقطة ارتكاز دلائل إرجاع الخيط
38 support for springs	الغزبة
39 carriage	مِسَار اختيار المُغْذِي
40 feeder-selecting device	أَبْدِي التشغيل
41 carriage handles	مقياس ضبط الغرز
42 scale for regulating size of stitches	عداد الصفوف الأفقية من الغرز
43 course counter (tachometer)	ذراع التحكم
44 machine control lever	قضيب العربة
45 carriage rail	الصف الخلفي من الإبر
46 back row of needles	الصف الأمامي من الإبر
47 front row of needles	القماش التريكو
48 knitted fabric	قضيب الثقل لتنظيم الشد على القماش
49 tension bar	ثقل تنظيم الشد
50 tension weight	قضيب الإبر وكيفية تكوين غرز التريكو
51 needle bed showing knitting action	الحافة العليا للمشببات الإبر مرتبة في وضع متواز
52 teeth of knock-over bit	دليل الخيط
53 needles in parallel rows	قضيب الإبر
54 yarn guide (thread guide)	لوحَة احتجاز الإبر ذات المساقطة
55 needle bed	كامرة دليل علوية
56 retaining plate for latch needles	كامرة الغرز
57 guard cam	كامرة رَفْع الإبر
58 sinker	كَبْ الإبرة
59 needle-raising cam	إبرة سقافة
60 needle butt	غُرْزَة تريكو
61 latch needle	دفع الإبرة خلال القماش
62 loop	دليل الخيط يُغْذِي خُطاف الإبرة بالخيط
63 pushing the needle through the fabric	تكوين الغُرْزَة
64 yarn guide (thread guide) placing yarn in the needle hook	انزلاق الغُرْزَة بعد تكوينها
65 loop formation	
66 casting off of loop	

168 Finishing of Textile Fabrics

1-65 finishing	التجهيز
1 rotary milling (fulling) machine for felting the woollen (Am. woolen) fabric	ماكينة تليد دَوَارَة لتليد الأقمشة الصوفية
2 pressure weights	ثقل ضاغط
3 top milling roller (top fulling roller)	درفيل التليد العلوي
4 drive wheel of bottom milling roller (bottom fulling roller)	طارة التشغيل المركزية على عمود درفيل التليد السفلي
5 fabric guide roller	درفيل دليلي (الأستوانة الأمامية) للقماش
6 bottom milling roller	درفيل التليد السفلي

أشغال الإبرة أو التريكو	
مشغل التريكو	
1-66 hosiery mill	
1 circular knitting machine for the manufacture of tubular fabric	ماكينة التريكو الدائرية لتصنيع القماش الأسطواني
2 yarn guide support post (thread guide support post)	عمود الارتكاز لدليل الخيط
3 yarn guide (thread guide)	دليل الخيط
4 bottle bobbin	بكرة على هيئة زجاجة
5 yarn-tensioning device	جهاز ضبط شد الخيط المغذي
6 yarn feeder	طارة لإدارة الماكينة يدويًا
7 handwheel for rotating the machine by hand	أستوانة الإبر (حامل الإبر الأسطواني)
8 needle cylinder (cylindrical needle holder)	قماش أسطواني
9 tubular fabric	حبة القماش (وعاء القماش)
10 fabric drum (fabric box, fabric container)	أستوانة الإبر (حامل الإبر)
11 needle cylinder (cylindrical needle holder) [section]	القماش الأسطواني [مقطع]
12 latch needles arranged in a circle	الإبر ذات الخُطاف / سقافة في نسق دائري
13 cam housing	مبيت الكامات
14 needle cams	كامات الإبر
15 needle trisk	مشببات الإبر
16 cylinder diameter (also: diameter of tubular fabric)	قطر أَسْطُوَانَة الإبر (وهو أيضا قطر القماش الأسطواني)
17 thread (yarn)	الخيط
18 Cotton's patent flat knitting machine for ladies' fully-fashioned hose	ماكينة تريكو لعمل جوارب السيدات
19 pattern control chain	كثبنة الضبط
20 side frame	العارضة الجانبية للماكينة
21 knitting head	رأس الغرز
22 starting rod	عمود بدء التشغيل
23 Raschel warp-knitting machine	ماكينة تريكو راشيل
24 warp (warp beam)	السداء (مطواة السداء)
25 yarn-distributing (yarn-dividing) beam	مطواة التقسيم
26 beam flange	طارة أَسْطُوَانَة السداء
27 row of needles	صف من الإبر
28 needle bar	قضيب (دليلي) للإبر
29 fabric (Raschel fabric) [curtain lace and net fabrics] on the fabric roll	القماش [داقتلا ستائر و قماش شبكي] على مطواة القماش
30 handwheel	عجلة الإدارة
31 motor drive gear	طارات تشغيل المحرك
32 take-down weight	ثقل السحب
33 frame	هيكل الماكينة
34 base plate	قاعدة الماكينة
35 hand flat (flat-bed)	ماكينة تريكو مسطحة تُشغل

24 loom framing	هيكل النول
25 metal shuttle tip	غراب المكوك المعدني
26 shuttle	مكوك
27 heald (heddle, wire heald, wire heddle)	ذراع
28 eye (eyelet, heald eyelet, heddle eyelet)	ثقب ذراع
29 eye (shuttle eye)	زردة المكوك
30 pilm	ماسورة اللخمة
31 metal contact sleeve for the weft feeler	جلبية التلامس المعدنية لمساس اللخمة
32 slot for the feeler	مشقبة حساس اللخمة
33 spring-clip pilm holder	ماسك زنبركي لكعب ماسورة اللخمة
34 drop wire	شريحة إيقاف، سقافة
35 weaving machine (automatic loom) [side elevation]	ماكينة نسج (نول آلي) [منظر جانبي]
36 heald shaft guiding wheels	بكر الدَوَار الدليلي
37 backrest	المستند الخلفي
38 lease rods	سَمَام الأَشْيَك
39 warp (warp thread)	السداء
40 shed	النفس
41 sley (slay)	ريشة الذاف
42 race board	الجورأ
43 stop rod blade for the stop motion	المصدام
44 bumper steel	الضفدة
45 bumper steel stop rod	بُزْر الضفدة
46 breast take-up roller	مسند الصدر
47 cloth take-up roller	أَسْطُوَانَة الصفرة
48 warp beam	أَسْطُوَانَة السداء
49 beam flange	طارة أَسْطُوَانَة السداء
50 crankshaft	عمود مرفقي
51 crankshaft wheel	ترس العمود المرفقي
52 connector	ذراع الذاف
53 sley (slay)	الذاف
54 lam rods	أسياع الدوار
55 camshaft wheel	ترس عمود الكامات السفلي
56 camshaft (tappet shaft)	عمود الكامات
57 tappet (shedding tappet)	الكامات
58 treadle lever	ذراع الدواسة
59 let-off motion	جهاز تنظيم انسياب السداء
60 beam motion control	طارة جهاز الانسياب
61 rope of the warp let-off motion	خيل جهاز الانسياب
62 let-off weight lever	ذراع الثقل (لجهاز الانسياب)
63 control weight [for the treadle]	ثقل التحكم (الدواسة)
64 picker with leather or bakelite pad	لطاشة ذات بطانة جلدية
65 picking stick buffer	مصدد ذراع القذف
66 picking cam	كامرة القذف
67 picking bowl	طاسة القذف
68 picking stick return spring	نابض إرجاع ذراع القذف

20	formation of cyclohexanone (pimehinketone)	تكوين الهيكسانول الحلقي
21	hydroxylamine inlet	مدخل الهيدروزيلاين
22	formation of cyclohexanoxime	تكوين الهيكسانوكسيم
23	addition of sulphuric acid (Am. sulfuric acid) to effect molecular rearrangement	إضافة حمض الكبريتيك لإنجاز إعادة التنظيم الجزيئي
24	ammonia to neutralize sulphuric acid (Am. sulfuric acid)	إضافة الأمونيا لمعادلة حمض الكبريتيك
25	formation of caprolactam oil	تكوين زيت الكبرولاكتم
26	ammonium sulphate (Am. ammonium sulfate) solution	محلول كبريتات الأمونيوم
27	cooling cylinder	أسطوانة تبريد
28	caprolactam	كبرولاكتم
29	weighing apparatus	جهاز الوزن، ميزان
30	melting pot	بوتقة انصهار
31	pump	مضخة
32	filter	مرشح، فلتر
33	polymerization in the autoclave	بلمرة في الأوتوكلاف
34	cooling of the polyamide	تبريد غريد الأמיד
35	solidification of the polyamide	تصلب غريد الأמיד
36	vertical lift (Am. elevator)	مرفق رأسي
37	extractor for separating the polyamide from the remaining lactam oil	فرازة غريد الأמיד
38	drier	مجفف
39	dry polyamide chips	شرائح غريد الأמיד الجافة
40	chip container	حاوية الشرائح
41	top of spinneret for melting the polyamide and forcing it through spinneret holes (spinning jets)	الجزء العلوي من فونية الغزل المخصص لصهر غريد الأמיד ودفعه خلال ثقوب الفونية
42	spinneret holes (spinning jets)	ثقوب فونية الغزل
43	solidification of polyamide filaments in the cooling tower	تصلب ألياف غريد الأמיד في برج التبريد
44	collection of extruded filaments into thread form	تجميع الألياف في شكل خيط
45	preliminary stretching (preliminary drawing)	الشد الأولي للخيط
46	stretching (cold-drawing) of the polyamide thread to achieve high tensile strength	سحب خيط غريد الأמיד على الباراد لإكسابه قوة لمقاومة الشد
47	final stretching (final drawing)	السحب النهائي

28	filament tow	حبل الألياف
29	overhead spray washing plant	وحدة غسل بالرش العلوي
30	cutting machine for cutting filament tow to desired length	ماكينة قطع حبل الألياف إلى الطول المرغوب
31	multiple drying machine for cut-up staple fibre (Am. fiber) layer (lap)	ماكينة تجفيف وقطع الألياف طويلة التيلة
32	conveyor belt (conveyor)	سير ناقل
33	baling press	مكبس البالات
34	bale of viscose rayon ready for dispatch (despatch)	بالة حرير الفسكون جاهزة للإرسال إلى التاجر

170 Synthetic (Man-made) Fibres (Am. Fibers) II

1-62	manufacture of polyamide (nylon 6, perlon) fibres (Am. fibers)	صناعة ألياف غديد الأמיד
1	coal [raw material for manufacture of polyamide (nylon 6, perlon) fibres (Am. fibers)]	فحم [مادة خام لصناعة ألياف غديد الأמיד (نايولون 6)]
2	coking plant for dry coal distillation	وحدة التكرية الخاصة بتقطير الفحم الجاف
3	extraction of coal tar and phenol and the oil	استخلاص قار الفحم والفينول
4	gradual distillation of tar	تقطير القار تدريجياً
5	condenser	المكثف
6	benzene extraction and dispatch (despatch)	استخلاص البنزين
7	chlorine	الكلور
8	benzene chlorination	كلورة البنزين
9	monochlorobenzene (chlorobenzene)	كلور بنزين أحادي (كلور بنزين)
10	caustic soda solution	محلول صودا كاوية
11	evaporation of chlorobenzene and caustic soda	تبخر الكلوربنزين والصودا الكاوية
12	autoclave	مجم مؤسد، أوتوكلاف
13	sodium chloride (common salt), a by-product	كلوريد صوديوم (ملح الطعام)، منتج ثانوي
14	phenol (carbolic acid)	الفينول (حمض الكربوليك)
15	hydrogen inlet	مدخل الهيدروجين
16	hydrogenation of phenol to produce raw cyclohexanol	هدرجة الفينول لإنتاج هيكسانول حلقي خام
17	distillation	التقطير
18	pure cyclohexanol	هيكسانول حلقي نقي
19	oxidation (dehydrogenation)	الأكسدة (نزع الهيدروجين)

5	pressing out excess caustic soda	صودا كاوية استخراج الصودا الكاوية الزائدة بالكبس
6	shredding the cellulose sheets	تقطيع ألواح السليولوز
7	maturing (controlled oxidation) of the alkali-cellulose crumbs	إنضاج قطع السليولوز القلوي
8	carbon disulphide (Am. carbon disulfide)	ثاني كبريتوز الكربون
9	conversion of alkali-cellulose into cellulose xanthate	تحويل السليولوز القلوي إلى سليولوز الزنثات
10	dissolving the xanthate in caustic soda for the preparation of the viscose spinning solution	إذابة الزنثات في الصودا الكاوية لإعداد محلول غزل الفسكون
11	vacuum ripening tanks	خزانات إنضاج بالتفريغ
12	filter presses	مكابس ترشيح
13-27	from viscose to viscose rayon thread	من الفسكون إلى خيط حرير الفسكون
13	metering pump	مضخة
14	multi-holed spinneret (spinning jet)	فونية غزل متعددة الثقوب
15	coagulating (spinning) bath for converting (coagulating) viscose (viscous solution) into solid filaments	حمام المادة العاقدة لتحويل محلول الفسكون إلى خيوط صلبة
16	Godet wheel, a glass pulley	بكرة "جوديه"
17	Topham centrifugal pot (box) for twisting the filaments into yarn	صندوق لتحويل الألياف إلى غزل
18	viscose rayon cake	كعكة حرير الفسكون
19-27	processing of the cake	معالجة الكعكة
19	washing	الغسيل
20	desulphurizing (desulphurization, Am. desulfurizing, desulfurization)	نزع الكبريت
21	bleaching	التفتيح (التبييض)
22	treating of cake to give filaments softness and suppleness	معالجة الكعكة لإكساب الشفيرات النعومة والليونة
23	hydro-extraction to remove surplus moisture	نزع الماء لإزالة الرطوبة الزائدة
24	drying in heated room	التجفيف في حجرة مسخنة
25	winding yarn from cake into cone form	لف الغزل من الكعكة إلى الشكل المخروطي
26	cone-winding machine	ماكينة لفة المخروط
27	viscose rayon yarn on cone ready for use	غزل حرير الفسكون على مخروط جاهز للاستخدام
28-34	from viscose spinning solution to viscose rayon staple fibre (Am. fiber)	من محلول غزل الفسكون إلى ألياف حرير الفسكون طويلة التيلة

41	heated press bowl	درّفيل الكي المسخن
42	rotary cloth-shearing machine	ماكينة قص الوبرة
43	suction slot, for removing loose fibres (Am. fibers)	أنبوب شفط عوادم الألياف
44	doctor blade (cutting cylinder)	أسطوانة قص الوبرة
45	protective guard	شبكة مصنعات واقية
46	rotating brush	فرشاة دوارة
47	curved scray entry	طليقة منحنية
48	treadle control	دواسة تحكم
49	[non-shrinking] decatizing (decatizing) fabric-finishing machine	ماكينة دكتزة [لتثبيت التجفيف]
50	perforated decatizing (decatizing) cylinder	درّفيل الدكتزة
51	piece of fabric	قطعة القماش
52	cranked control handle	عمود مرفقي
53	ten-colour (Am. ten-color) roller printing machine	ماكينة طباعة قماش ذات عشر أسطوانات ألوان
54	base of the machine	قاعدة الماكينة
55	drive motor	محرك الإدارة
56	blanket [of rubber or felt]	غطاء [من المطاط أو الفيل]
57	fabric after printing (printed fabric)	القماش بعد طباعته
58	electric control panel (control unit)	لوحة التحكم الكهربائية
59	screen printing	الطباعة بالشيلونات
60	mobile screen frame	شيلونة متحركة
61	squeegee	ضامط لتوزيع اللون على الشيلونة
62	pattern stencil	شيلونة الطباعة
63	screen table	منضدة الطباعة بالشيلونة
64	fabric gummed down on table ready for printing	القماش المثبت على منضدة الطباعة تمهيداً لطباعته
65	screen printing operator (operative)	عامل الطباعة بالشيلونة

169 Synthetic (Man-made) Fibres (Am. Fibers) I

1-34	manufacture of continuous filament and staple fibre (Am. fiber) viscose rayon yarns by means of the viscose process	صناعة الألياف المستمرة وخيوط غزل حرير الفسكون طويلة التيلة عن طريق عملية تصنيع الفسكون
1-12	from raw material to viscose rayon	من المادة الخام إلى حرير الفسكون
1	basic material [beech and spruce cellulose in form of sheets]	المادة الأساسية [بيلولوز الزان والرايبينجيات في شكل ألواح]
2	mixing cellulose sheets	مزج ألواح السليولوز
3	caustic soda	صودا كاوية
4	steeping cellulose	ألواح سليولوز منقوعة في

43 green liquor preheater	مُزَجِّع السائل الأخضر
44 concentrator (thickener, decker) for the weak wash liquor (wash water)	مُزَجِّع السائل الضعيف
45 storage tank for the weak liquor	خزان سائل الطبخ
46 storage tank for the cooking liquor	مخزن سائل الطبخ
47 agitator (stirrer)	محرّك آلية التقليب
48 concentrator (thickener, decker)	مُعَلِّظ القوام
49 causticizing agitators (causticizing stirrers)	محرّك آلية الصّالحيّة بالصودا الكاوية
50 classifier	آلية تصنيف
51 lime slaker	وحدة إطفاء الجير
52 reconverted lime	جير مسترجع
53-65 groundwood mill (mechanical pulp mill) [diagram]	ماكينة إعداد لب الخشب
53 continuous grinder (continuous chain grinder)	جلاخة مستمرة (جلاخة بسلسلة مقفولة)
54 strainer (knotter)	مُشَلِّط، مضمّعة
55 pulp water pump	مضخة ماء اللب
56 centrifugal screen	غُرْبَال نابذ
57 screen (sorter)	غُرْبَال، مُشَلِّط
58 secondary screen (secondary sorter)	غُرْبَال ثانوي
59 rejects chest	صندوق الفضلات
60 conical refiner (cone refiner, Jordan, Jordan refiner)	جهاز تنعيم مخرّوطي الشكل
61 pulp-drying machine (pulp machine)	ماكينة تجفيف لب الخشب
62 concentrator (thickener, decker)	مُعَلِّظ القوام
63 waste water pump (white water pump, pulp water pump)	مضخة الماء المهودر
64 steam pipe	أنبوب البخار
65 water pipe	أنبوب الماء
66 continuous grinder (continuous chain grinder)	جلاخة مستمرة (جلاخة بسلسلة مقفولة)
67 feed chain	حصيرة التغذية
68 groundwood	خشب شجر
69 reduction gear for the feed chain drive	تروس تخفيض سرعة إدارة
70 stone-dressing device	حصيرة التغذية
71 grinding stone (grind-stone, pulpstone)	آلية الصقل بحجر التليج
72 spray pipe	حجر تليج
73 conical refiner (cone refiner, Jordan, Jordan refiner)	أنبوب الرش
74 handwheel for adjust-	جهاز تنعيم مخرّوطي الشكل

48 washing of yam packages	غَسِيل عبوات الخيط
49 drying chamber	غرفة التجفيف
50 rewinding	إعادة لف الخيط
51 polyamide cone	مخرّوط غنيد الأמיד
52 polyamide cone ready for dispatch (despatch)	مخرّوط غنيد الأמיד جاهز لإرساله للتاجر
53 mixer	خلاط
54 polymerization under vacua	بلمرة تحت تفريغ
55 stretching (drawing)	سحب الخيط
56 washing	غسيل
57 finishing of tow for spinning	تجهيز خيوط الألياف للغزل
58 drying of tow	تجفيف خيوط الألياف
59 crimping of tow	تمويج خيوط الألياف
60 cutting of tow into normal staple lengths	قطع خيوط الألياف إلى أطوال عادية
61 polyamide staple	غنيد الأמיד طويل التيلة
62 bale of polyamide staple	بالة غنيد الأמיד طويل التيلة
171 Weaves and Knits	النسج وغزل التريكو
1-29 weaves [black squares: warp thread raised, weft thread lowered; white squares: weft thread raised, warp thread lowered]	النسج [المربعات السوداء: خيط السداة لأعلى، خيط اللحمة لأسفل؛ المربعات البيضاء: خيط اللحمة لأعلى، خيط السداة لأسفل]
1 plain weave (tabby weave) [weave viewed from above]	نسج سادة [منظر النسج من أعلى]
2 warp thread	خيط السداة
3 weft thread	خيط اللحمة
4 draft (point paper design) for plain weave	باترون (ورق مربعات) للنسج السادة
5 threading draft	نظام اللقي للضم الخيط
6 denting draft (reed-threading draft)	نظام اللقي للضم المنشط
7 raised warp thread	خيط السداة فوق خيط اللحمة
8 lowered warp thread	خيط اللحمة أسفل خيط السداة
9 tie-up of shafts in pairs	ربط النسج زوجياً
10 treading diagram	مخطّط سير الدواسة
11 draft for basket weave (hopsack weave, matt weave)	نظام لقي النسج الشبكي (نسج سادة ممتد)
12 pattern repeat	باترون تكرر
13 draft for warp rib weave	نظام اللقي الخاص بنسج سادة ممتد في اتجاه السداة
14 section of warp rib fabric, a section through the warp	جزء من تليجات السداة
15 lowered weft thread	خيط اللحمة أسفل السداة
16 raised weft thread	خيط اللحمة أعلى السداة
17 first and second warp threads [raised]	خيطا السداة الأول والثاني [فوق السداة]
18 third and fourth warp	خيطا السداة الثالث والرابع
19 draft for combined rib weave	نظام اللقي الخاص بالنسج المصّلع المدمج
20 selvedge (selvage) thread draft (additional shafts for the selvedge)	نظام لقي البرسّل
21 draft for the fabric shafts	نظام لقي نسج القماش
22 tie-up of selvedge (selvage) shafts	ربط نسج البرسّل
23 tie-up of fabric shafts	ربط نسج القماش
24 selvedge (selvage) in plain weave	البرسّل في نسج سادة
25 section through combination rib weave	جزء من نسج مصلّع مدمج
26 thread interlacing of reversible warp-faced cord	تداخل خيوط في كردون السداة السطحي المستعمل على الوجهين
27 draft (point paper design) for reversible warp-faced cord	باترون (ورق مربعات) كردون السداة السطحي المستعمل على الوجهين
28 interlacing points	مربعات متداخلة
29 weaving draft for honeycomb weave in the fabric	نظام نسج خلايا النحل في القماش
30-48 basic knits	غزل التريكو الأساسية
30 loop, an open loop	أشطولة، أشطولة مفتوحة، بوكلي
31 head	رأس الأشطولة
32 side	جانب الأشطولة
33 neck	عنق الأشطولة
34 head interlocking point	نقطة التعاشق بالرأس
35 neck interlocking point	نقطة التعاشق بالعنق
36 closed loop	أشطولة متغلّقة
37 mesh [with inlaid yarn]	شبكة [بغزل وبيري]
38 diagonal floating yarn (diagonal floating thread)	غزل تنسيق مائل
39 loop interlocking at the head	أشطولة متعاشقة بالرأس
40 float	تنسيق
41 loose floating yarn (loose floating thread)	غزل تنسيق سائب
42 course	صفّ غزل أفقي
43 inlaid yarn	غزل وبيري
44 tuck and miss stitch	غرزة مقفولة
45 pulled-up tuck stitch	غرزة عدلة
46 staggered tuck stitch	غرزة عدلة متناثرة
47 2 x 2 tuck and miss stitch	غرزة مقفولة مزدوجة
48 double pulled-up tuck stitch	غرزة عدلة مزدوجة
172 Papermaking I	صناعة الورق (1)
1-52 sulphate (Am. sulfate) pulp mill (kraft pulp mill) [in diagram form]	ماكينة إعداد لب الكبريتات (ماكينة إعداد لب كرافت) [في شكل مخطط]
1 chippers with dust	وحدات إعداد الجذّاعة و
2 rotary screen (riffler)	غُرْبَال دَوّار (حوض فصل الرمال)
3 chip packer (chip distributor)	موزع الجذّاعة
4 blower	نفاخ
5 disintegrator (crusher, chip crusher)	جِرْاشَة، كَسّارَة
6 dust-settling chamber	خِجْرَة ترسيب الأتربة
7 digester	مِرْجِل تسخين خامات الورق
8 liquor preheater	مُسخِّن مُقدّم للسائل
9 control tap	مُحْبِس
10 swing pipe	أَنْبُوب تَارِجِي
11 blow tank (diffuser)	خَزَان التَفْخِيع
12 blow valve	صمام التَفْخِيع
13 blow pit (diffuser)	خِجْرَة التَفْخِيع
14 turpentine separator	فِرَازَة التَرْتِين
15 centralized separator	فِرَازَة مَرَكِزِيَة
16 jet condenser (injection condenser)	مُكثّف نِغَاط (مُكثّف حَقْن)
17 storage tank for condensate	خَزَان ناتج التَكيث
18 hot water tank	خَزَان الماء الساخن
19 heat exchanger	مُبادِل حراري
20 filter	فِلتر، مَرْشِيع
21 presorter	فِرَاز مُقدّم
22 centrifugal screen	غُرْبَال نابذ
23 rotary sorter (rotary strainer)	فِرَاز دَوّار (مُشَلِّط دَوّار)
24 concentrator (thickener, decker)	مُعَلِّظ القوام
25 vat (chest)	راقود
26 collecting tank for backwater (low box) العرّيج/المرّند	خَزَان تجميع الماء العرّيج/المرّند
27 conical refiner (cone refiner, Jordan, Jordan refiner)	جهاز تنعيم مخرّوطي الشكل
28 black liquor filter	مُرْشِيع السائل الأسود
29 black liquor storage tank	خَزَان السائل الأسود
30 condenser	مُعَلِّظ القوام
31 separators	فِرَازَات
32 heaters (heating elements)	سَخَّانَات
33 liquor pump	مضخة السائل
34 heavy liquor pump	مضخة السائل الثقيل
35 mixing tank	خَزَان المِزَاج
36 salt cake storage tank (sodium sulphate storage tank)	خَزَان كبريتات الصوديوم
37 dissolving tank (dissolver)	خَزَان الإذابة
38 steam heater	سَخَّان بخاري
39 electrostatic precipitator	مُرْسِب الكهروستاتي
40 air pump	مضخة هوائية
41 storage tank for the uncleaned green liquor	خَزَان السائل الأخضر غير التبي
42 concentrator (thickener,	مُعَلِّظ القوام

29 Linotype matrix	أُمّ الحَرْف (متريسي) للجمع النطري
30 teeth for the distributing mechanism (distributor)	أسنان للتحرّك على موزّع أُمّهات الحروف
31 face (type face, matrix)	وَجْه الحَرْف (السَّلْع الطباعي)
32-45 monotype single-unit composing (typesetting) and casting machine (monotype single-unit composition caster)	ماكينة الجمع الحرفي والمنسك
32 monotype standard composing (typesetting) machine (keyboard)	ماكينة الجمع الحرفي المونوتيب
33 paper tower	بُرْج بوبينة الورق (ورق المونوتيب)
34 paper ribbon	شريط الورق
35 justifying scale	أسطوانة ضبط مقياس السطر
36 unit indicator	وحدة تحديد ثخانة الحرف
37 keyboard	لوحة المفاتيح
38 compressed-air hose	خُرطوم توصيل الهواء المضغوط
39 monotype casting machine (monotype caster)	ماكينة سبك حرفي
40 automatic metal feeder	حامل سبيكة الرصاص لتغذية حلة الرصاص
41 pump compression spring (pump pressure spring)	نابض لضبط ضغط مضخة الرصاص
42 matrix case (die case)	إطار أُمّهات الحروف (كفّ المتاريس)
43 paper tower	بُرْج بوبينة الورق
44 galley with types (letters, characters, cast single types, cast single letters)	صينية (جاليه) الحروف المنسوجة
45 electric heater (electric heating unit)	وحدة التسخين الكهربائي لحوض المعدن
46 matrix case (die case)	إطار الأُمّهات
47 type matrices (matrixes) (letter matrixes)	أُمّهات الحروف (طقم متاريس بالمتاريسه)
48 guide block for engaging with the cross-slide guide	مشقّبية كفّ المتاريس
175 Typesetting Room (Composing Room) II	قسم الجمع الطباعي (2)
1-17 composition (type matter, type)	الجمع (نصّ مجموع)
1 initial (initial letter)	الحرف الإستهلالي
2 bold type (bold, bold-faced type, heavy type, boldface)	حرف أسود (غامق)
3 semibold type (semi-	حرف نصف أسود (نصف

عجينة جاهزة لإباد	قسم الجمع الطباعي (1)
قسم الجمع اليدوي	قسم الجمع اليدوي
منضدة (سبية) صناديق الحروف	منضدة (سبية) صناديق الحروف
سندوق حروف	سندوق حروف
ذولاب حفظ صناديق الحروف	ذولاب حفظ صناديق الحروف
جسّاع يدوي	جسّاع يدوي
أصل مَحْطوط حروف مطبّعة	أصل مَحْطوط حروف مطبّعة
رَفّ (صندوق) التواضيب (الرفاقق)	رَفّ (صندوق) التواضيب (الرفاقق)
درج المصفّحات المحفوظة	درج المصفّحات المحفوظة
تخزين الفورمات	تخزين الفورمات
صفحة مَحْطوطة	صفحة مَحْطوطة
صينية "جاليه" المصفّ	صينية "جاليه" المصفّ
مسطرة المصفّ	مسطرة المصفّ
نصّ مجموع	نصّ مجموع
سلك المصفّحة	سلك المصفّحة
مخزّن	مخزّن
ملقاط	ملقاط
ماكينة جمع سطري (البيوتيب)، ماكينة متعددة مخارن المتريسات	ماكينة جمع سطري (البيوتيب)، ماكينة متعددة مخارن المتريسات
موزّع الأُمّهات (المتريسات)	موزّع الأُمّهات (المتريسات)
مخزّن أُمّهات الحروف	مخزّن أُمّهات الحروف
الذراع الرافعة لنقل الأُمّهات إلى الموزّع	الذراع الرافعة لنقل الأُمّهات إلى الموزّع
سندوق التجميع	سندوق التجميع
رفاقق الفصل	رفاقق الفصل
آلية السبك	آلية السبك
التغذية بمعدّن الحروف	التغذية بمعدّن الحروف
صينية الأسطر المنسوجة	صينية الأسطر المنسوجة
أُمّهات للإيلاج اليدوي	أُمّهات للإيلاج اليدوي

50 post ready for pressing	عجينة جاهزة
51 felt	لإباد
174 Typesetting Room (Composing Room) I	قسم الجمع الطباعي (1)
1 hand-setting room (hand-composing room)	قسم الجمع اليدوي
2 composing frame	منضدة (سبية) صناديق الحروف
3 case (typecase)	سندوق حروف
4 case cabinet (case rack)	ذولاب حفظ صناديق الحروف
5 hand compositor (compositor, typesetter, maker-up)	جسّاع يدوي
6 manuscript (typescript)	أصل مَحْطوط
7 sorts (types, type characters, characters)	حروف مطبّعة
8 rack (case) for furniture (spacing material)	رَفّ (صندوق) التواضيب (الرفاقق)
9 standing type rack (standing matter rack)	درج المصفّحات المحفوظة
10 storage shelf (shelf for storing formes, Am. forms)	تخزين الفورمات
11 standing type (standing matter)	صفحة مَحْطوطة
12 galley	صينية "جاليه" المصفّ
13 composing stick (setting stick)	مسطرة المصفّ
14 composing rule (setting rule)	نصّ مجموع
15 type (type matter, matter)	سلك المصفّحة
16 page cord	مخزّن
17 bodkin	ملقاط
18 tweezers	ماكينة جمع سطري (البيوتيب)، ماكينة متعددة مخارن المتريسات
19 Linotype line-composing (line-casting, slug-composing, slug-casting) machine, a multi-magazine machine	ماكينة جمع سطري (البيوتيب)، ماكينة متعددة مخارن المتريسات
20 distributing mechanism (distributor)	موزّع الأُمّهات (المتريسات)
21 type magazines with matrices (matrixes)	مخزّن أُمّهات الحروف
22 elevator carrier for distributing the matrices (matrixes)	الذراع الرافعة لنقل الأُمّهات إلى الموزّع
23 assembler	سندوق التجميع
24 spacebands	رفاقق الفصل
25 casting mechanism	آلية السبك
26 metal feeder	التغذية بمعدّن الحروف
27 machine-set matter (cast lines, slugs)	صينية الأسطر المنسوجة
28 matrices (matrixes) for hand-setting (sorts)	أُمّهات للإيلاج اليدوي

أُتوب قائم	ماكينة صنع الورق (خط إنتاج) [مَحْط]
آلية تغذية من سندوق الماكينة (سندوق العجينة) وبها فزاز ومصفاة	آلية تغذية من سندوق الماكينة (سندوق العجينة) وبها فزاز ومصفاة
سلك (سلك الماكينة)	سلك (سلك الماكينة)
سندوق تقريع	سندوق تقريع
ذولفين شقط	ذولفين شقط
ليّاد التليل الأولي	ليّاد التليل الأولي
ليّاد التليل الثاني	ليّاد التليل الثاني
المكبّس الأول	المكبّس الأول
المكبّس الثاني	المكبّس الثاني
مكبّس أوفست	مكبّس أوفست
ذولفين التجفيف (مَجْفف)	ذولفين التجفيف (مَجْفف)
ليّاد تحفييف	ليّاد تحفييف
مكبّس تقويم (قَلْفَة أو معالّجة بالراتجات)	مكبّس تقويم (قَلْفَة أو معالّجة بالراتجات)
ذولفين التبريد	ذولفين التبريد
دلافين منقل الأفرخ	دلافين منقل الأفرخ
غطاء الماكينة	غطاء الماكينة
بكرة سحب الورق	بكرة سحب الورق
ماكينة تكسية نصليّة	ماكينة تكسية نصليّة
ورق خام	ورق خام
شريط الورق	شريط الورق
آلية تكسية الجانب العلوي	آلية تكسية الجانب العلوي
مَجْفف بالأشعة تحت الحمراء	مَجْفف بالأشعة تحت الحمراء
ذولفين تجفيف مسخّن	ذولفين تجفيف مسخّن
آلية تكسية الجانب السفلي (جانب السلك)	آلية تكسية الجانب السفلي (جانب السلك)
بكرة الورق المكسّم	بكرة الورق المكسّم
ماكينة تشكيل وصقل الأفرخ	ماكينة تشكيل وصقل الأفرخ
نظام هيدرولي لدلافين الكبس	نظام هيدرولي لدلافين الكبس
أسطوانة الماكينة	أسطوانة الماكينة
مَحْطَة فلك لفة الورق	مَحْطَة فلك لفة الورق
منضدة رقع	منضدة رقع
مَحْطَة إعادة لفة الورق	مَحْطَة إعادة لفة الورق
سكين لفة الورق	سكين لفة الورق
لوحة التحكم	لوحة التحكم
سكين (آلية القطع)	سكين (آلية القطع)
شريط الورق	شريط الورق
صناعة الورق يدويًا	صناعة الورق يدويًا
عامل الراقود	عامل الراقود
راقود	راقود
قالب	قالب
عامل فرد العجينة	عامل فرد العجينة

a paper machine	ماكينة صنع الورق (خط إنتاج) [مَحْط]
12 standpipe	أُتوب قائم
13-28 paper machine (production line) [diagram]	ماكينة صنع الورق (خط إنتاج) [مَحْط]
13 feed-in from the machine chest (stuff chest) with sand table (sand trap, riffler) and knotter	آلية تغذية من سندوق الماكينة (سندوق العجينة) وبها فزاز ومصفاة
14 wire (machine wire)	سلك (سلك الماكينة)
15 vacuum box (suction box)	سندوق تقريع
16 suction roll	ذولفين شقط
17 first wet felt	ليّاد التليل الأولي
18 second wet felt	ليّاد التليل الثاني
19 first press	المكبّس الأول
20 second press	المكبّس الثاني
21 offset press	مكبّس أوفست
22 drying cylinder (drier)	ذولفين التجفيف (مَجْفف)
23 dry felt (drier felt)	ليّاد تحفييف
24 size press	مكبّس تقويم (قَلْفَة أو معالّجة بالراتجات)
25 cooling roll	ذولفين التبريد
26 calender rolls	دلافين منقل الأفرخ
27 machine hood	غطاء الماكينة
28 delivery reel	بكرة سحب الورق
29-35 blade coating machine (blade coater)	ماكينة تكسية نصليّة
29 raw paper (body paper)	ورق خام
30 web	شريط الورق
31 coater for the top side	آلية تكسية الجانب العلوي
32 infrared drier	مَجْفف بالأشعة تحت الحمراء
33 heated drying cylinder	ذولفين تجفيف مسخّن
34 coater for the underside (wire side)	آلية تكسية الجانب السفلي (جانب السلك)
35 reel of coated paper	بكرة الورق المكسّم
36 calender (super-calender)	ماكينة تشكيل وصقل الأفرخ
37 hydraulic system for the press rolls	نظام هيدرولي لدلافين الكبس
38 calender roll	أسطوانة الماكينة
39 unwind station	مَحْطَة فلك لفة الورق
40 lift platform	منضدة رقع
41 rewind station (rewinder, re-reeler, reeling machine, re-reeling machine)	مَحْطَة إعادة لفة الورق
42 roll cutter	سكين لفة الورق
43 control panel	لوحة التحكم
44 cutter	سكين (آلية القطع)
45 web	شريط الورق
46-51 papermaking by hand	صناعة الورق يدويًا
46 vatman	عامل الراقود
47 vat	راقود
48 mould (Am. mold)	قالب
49 coucher (couchman)	عامل فرد العجينة

ing the clearance between the knives (blades)	السكاكين (الأضمال)
75 rotating bladed cone (rotating bladed plug)	مَحْطوط دَوّار مَمْلُ
76 stationary bladed shell	غلاف مَمْلُ ثابت
77 inlet for unrefined cellulose (chemical wood pulp, chemical pulp) or groundwood pulp (mechanical pulp)	فتحة دخول السليلوز غير المُنَقّي (اللب الكيميائي) أو لب الخشب
78 outlet for refined cellulose (chemical wood pulp, chemical pulp) or groundwood pulp (mechanical pulp)	فتحة خروج السليلوز المُنَقّي (اللب الكيميائي) أو لب الخشب
79-86 stuff (stock) preparation plant [diagram]	عجينة اللب المروية [رسم تخطيطي]
79 conveyor belt (conveyor) for loading cellulose (chemical wood pulp, chemical pulp) or groundwood pulp (mechanical pulp)	سُرّ ناقل الشحن السليلوز (اللب الكيميائي) أو لب الخشب
80 pulper	جهاز نزع اللب
81 dump chest	صندوق الإغراق/التفريغ
82 cone breaker	كُسارة مخروطية
83 conical refiner (cone refiner, Jordan, Jordan refiner)	جهاز تنعيم مَحْطوطي الشكل
84 refiner	جهاز تنعيم/تنقية
85 stuff chest (stock chest)	سندوق عجينة اللب المروية
86 machine chest (stuff chest)	سندوق الماكينة
173 Papermaking II (2)	صناعة الورق (2)
1 stuff chest (stock chest, machine chest), a mixing chest for stuff (stock)	سندوق عجينة اللب المروية
2-10 laboratory apparatus (laboratory equipment) for analysing stuff (stock) and paper	أجهزة معملية لتحليل عجينة اللب المروية
2 Erlenmeyer flask	مِخْطَار مَحْطوطي
3 volumetric flask	مِخْطَار حَجْمِي، قارورة حَجْمِيّة
4 measuring cylinder	مِخْطَار قياس
5 Bunsen burner	لهب/موقد بنزن
6 tripod	حامل ثلاثي
7 petri dish	جَفْة، صَفْحَة "بِترِي"
8 test tube rack	حامل أنابيب اختبار
9 balance for measuring basis weight	ميزان لقياس الوزن الأساسي
10 micrometer	ميكرومتر
11 centrifugal cleaners ahead of the breastbox (headbox, stuff box) of	وَحَدَات تنظيف العجينة قبل ذهابها إلى سندوق ماكينة صنع الورق

عَدَسَةٌ
كَلْفُ الْمَتَارِيسِ
عَدَسَةٌ مَكْتَفَةٌ
مُضَاعَفُ الْبِتَارِ
الكهروضوئي
نظام الإخراج
مُضَخِّمُ الإشارات الحاملة
للصور
أَنْبُوبُ توليد الحروف
سَطْحُ التعريض للضوء
كَلْفُ الْمَتَارِيسِ
مَنْقُوبَةٌ كَلْفُ الْمَتَارِيسِ

177 Photomechanical Reproduction

آلة تَصْوِيرٍ وتجميع رأسيّة
شاشة استقبال الصورة
حامل شاشة مفصلي
مقياس التثبيت
كوسنول التحكم
لوحة تحكم مركبة على
مفصلات
إيضاحات نسبة التركيز
النوري
حامل الفيلم
خزّانة الشاشة
منفاخ الكاميرا
مَقْدَمُ (واجهة) العَدَسَةِ
جهاز عداد
حامل علوي
لوحة (تخفة) الأضوال المراد
تصويرها
حامل [ماسك] الأصل
المراد تصويره
حامل مصابيح محوري
مصباح زنون للتصوير
الأصل المراد تصويره
تخفد تهذيب وقطع الأفلام
شاشة ضوئية
مقبض تعديل ارتفاع
وزاوية ميل النضد
لوحة الأصل
عدسة فحص الصورة
آلة تصوير عامة للاستنساخ
والتحميض
جسم الكاميرا
منفاخ الكاميرا
حامل العَدَسَةِ
مرآة مائلة
حامل
لوحة الأصل

مَكُونَاتُ الجَمْعِ المباشرة
طرقية المونتاج
وحدة معالجة مركزية
وحدة الشريط الممتنط
وحدة الأفراس الممتنطة
طابعة بالليزر
ماكينة جمع تصويري
حصّر النص
جماع تصويري

شاشة
مشغل القرص المرز
حاسب آلي ووحدة ذاكرة
مع وحدة معالجة مركزية
وقرص ممتنط
قارة
قاعدة القارة
لوحة المفاتيح
وحدة جمع تصويري
بإدخال مباشر
برامج النشر المكتبي
النوري
قرص مرز وعليه برامج
النصوص والتنسيق
والرسوم البيانية
ماسح (سكانر) أفقي
حاسب آلي شخصي
مطبوعات (صفحة مطبوعة
من الحاسوب)
وحدة معالجة بشبكة خطوط
المسح
وحدة جمع تصويري
بالليزر
بروفة
شاشة عالية الوضوح

نافذة عرض
البرامترات الطباعية
نافذة الأوامر الطباعية
جهاز نسخ الفيلم
وحدة جمع بأنبوب أشعة
الكاثود
نظام المسح
أنبوب أشعة كاثود ماسح

7 on-line configuration
8 make-up terminal (page make-up terminal)
9 central processing unit (typesetting computer)
10 magnetic tape unit (magnetic tape drive)
11 disk store
12 printer, n laser printer
13 phototypesetting machine (photo-typesetter)
14 text capture (text-capture terminal)
15 typesetter (keyboard or typographer)
16 screen (monitor)
17 floppy disk drive
18 computer and memory unit with central processing unit and hard disk
19 mouse, an input device
20 mouse mat
21 keyboard, an input device
22 direct-entry phototype-setter
23-33 desktop publishing (DTP)
23 diskette (floppy disk) with text, layout, and graphics programs
24 scanner (flat-bed scanner)
25 personal computer (PC) or workstation
26 printout (computer printout)
27 raster image processor (RIP)
28 laser phototypesetter
29 proof
30 high-resolution graphics screen, a large-format colour monitor
31 display window
32 typographic parameters
33 (typographic) command window
34 film copier
35-46 cathode ray tube (CRT) typesetter
35 scanning system
36 scan-generating (scanning) cathode ray tube (CRT)

إِسْطَيْبَةُ صَلْبٌ مَجْهَرَةٌ
أَمُ الحَرْفِ المسبوكة
حَرْفٌ مطبعي
رَأْسُ الحَرْفِ
كُتْفُ الحَرْفِ
تجويف الحَرْفِ
وَجْهُ الحَرْفِ (السَطْحُ الطباعي)
خَطُّ القاعدة
ارتفاع الحَرْفِ
ارتفاع كُتْفِ الحَرْفِ
حجم جسم الحَرْفِ (البطن)

الحزبة
العرض
آلة قَطْعٍ وتشكيل الأَمْهَاتِ والأحرف المطبعية
عُمُودٌ حامل
عَدَةُ القَطْعِ
نُضْدُ القَطْعِ
حامل المَشْأَخِ (البالتوجراف)
دلائل منشورية
نُضْدُ النموذج
تابع
المَشْأَخِ (البالتوجراف)
قائمة أم الحَرْفِ/المترس
عُمُودُ القَطْعِ
مُحَرِّكُ الإدارة

قسم الجمع الطباعي (الجمع التصوري) (3)

مَكُونَاتُ الجَمْعِ التصوري
مَكُونَاتُ الجَمْعِ المستقلة
حصّر البيانات
طرقية إدخال نص بدون هيئة
طرقية حصّر النص
والتصحیح
طرقية تنسيق الصفحة
حامل البيانات، قرص مرز
وحدة الجمع التصوري

36 finished steel punch (finished steel die)
37 punched matrix (stamped matrix, strike, drive)
38 type (type character, character)
39 head
40 shoulder
41 counter
42 face (type face)
43 type line (bodyline)
44 height to paper (type height)
45 height of shank (height of shoulder)
46 body size (type size, point size)
47 nick
48 set (width)
49 matrix-boring machine (matrix-engraving machine), a special-purpose boring machine
50 stand
51 cutter (cutting head)
52 cutting table
53 pantograph carriage
54 V-way
55 pattern
56 pattern table
57 follower
58 pantograph
59 matrix clamp
60 cutter spindle
61 drive motor

176 Typesetting Room III (Phototypesetting, Photocomposition, Photosetting)

1-21 phototypesetting configurations
1 off-line configuration
2 & 3 data capture
2 terminal for keying unformatted text
3 text capture and correction terminal
4 layout terminal (page-layout terminal)
5 data carrier, n diskette (floppy disk)
6 (photo)typesetting unit (phototypesetter)

غامق)
4 line
5 space
6 ligature (double letter)
7 italic type (italics)
8 light face type (light face)
9 extra bold type (extra bold)
10 bold condensed type (bold condensed)
11 majuscule (capital letter, capital, upper case letter)
12 minuscule (small letter, lower case letter)
13 letter spacing (inter-spacing)
14 small capitals
15 break
16 indentation
17 space
18 type sizes [one typographic point = 0.376 mm (Didot system), 0.351 mm (Pica system)]
19 six-two-pica (2 points)
20 half nonpareil (four-topica) (3 points)
21 brilliant (4 points); sim.: diamond (4 1/2 points)
22 pearl (5 points); sim.: ruby (Am. agate) (5 1/2 points)
23 nonpareil (6 points); sim.: minionette (6 1/2 points)
24 minion (7 points)
25 brevier (8 points)
26 bourgeois (9 points)
27 long primer (10 points)
28 pica (12 points)
29 English (14 points)
30 great primer (two-line brevier, Am. Columbian) (16 points)
31 paragon (two-line primer) (20 points)
32-37 typefounding (type casting)
32 punch cutter
33 graver (burin, cutter)
34 magnifying glass (magnifier)
35 punch blank (die blank)

غَامِقٌ
سَطْرٌ
مَسَافَةٌ (بين الأسطر)
حَرْفٌ مَرْدُودٌ
حَرْفٌ مَائِلٌ
حَرْفٌ فاتح
حَرْفٌ أَسْوَدٌ أكبر حجماً
حَرْفٌ أَسْوَدٌ ضيق
حَرْفٌ أَجْنَبِي كبير (حَرْفٌ كَابِتَالٌ)
حَرْفٌ أَجْنَبِي صغير
فَوْصَلَةٌ الحروف
أَحْرَفٌ كَابِتَالٌ صغيرة الحجم
سَطْرٌ ناقص
فِراغٌ يَتْرَكُ في بداية الفقرة
مَسَافَةٌ
أَحْجَامُ الحروف الطباعية [البطن الطباعي = 0,376 ملم (نظام الديوت)، 0,351 ملم (نظام بيكا)]
بِنْتَانٌ
ثَلَاثَةُ أَيْتَاطٍ
"بريليات" (4 أَيْتَاطٍ)
بِالمثل «دايموند» (4.5 بنت)
"بيرل" (5 أَيْتَاطٍ)
بِالمثل «روبي» (5.5 بنت)
"نونيريل" (6 أَيْتَاطٍ)
بِالمثل «مينيونيت» (6.5 بنت)
"مينيون" (7 أَيْتَاطٍ)
"بريفيه" (8 أَيْتَاطٍ)
"بورجواز" (9 أَيْتَاطٍ)
"بريمر طويل" (10 أَيْتَاطٍ)
"بيكا" (12 بنتاً)
"إنجليزي" (14 بنتاً)
"جريت بريمر" (16 بنتاً)
"باراجون" (20 بنتاً)
سَبْكُ الحروف الطباعية
حَفَّارُ الاسْطِطِمَاتِ
أَرْمِيلُ الحفر
نظارة مكبرة
قَابِلٌ (إِسْطَيْبَةٌ)

31 halogen lamp	مصباح هالوجين
32 vertical process camera, ■ compact camera	كاميرا تضييق رأسية
33 camera body	جسم الكاميرا
34 focusing screen (ground glass screen)	شاشة استقبال الصورة
35 vacuum back	ظهر خوائي
36 control panel	لوحة التحكم
37 flash lamp	مصباح الفلاش
38 mirror for right-reading images	مرآة لضبط وضوح الصورة
39 scanner (colour, <i>Am.</i> color, correction unit)	جهاز قرّز الألوان (سكاند)
40 base frame	قاعدة الجهاز
41 lamp compartment	خبيزة المصابيح
42 xenon lamp housing	مبيت مصباح زينون
43 feed motors	مُحرّكات الإقلام
44 transparency arm	ذراع الشفافيات
45 scanning drum	أسطوانة قرّز الألوان
46 scanning head	رأس قرّز الألوان
47 mask-scanning head	رأس مسح "الماسك"
48 mask drum	أسطوانة "الماسك"
49 recording space	حيز التسجيل
50 daylight cassette	خزّانة فيلم نهائية
51 colour (<i>Am.</i> color) computer with control unit and selective colour correction	كمبيوتر ألوان ذو وحدة تحكم وتصحيح ألوان انتقائية
52 engraving machine	ماكينة حفر
53 seamless engraving adjustment	تعديل الحفر غير الدرزي
54 drive clutch	قابض الإدارة
55 clutch flange	شقيف القابض
56 drive unit	وحدة الإدارة
57 machine bed	قاعدة الماكينة
58 equipment carrier	حامل المعدات
59 bed slide	زلافة القاعدة
60 control panel	لوحة التحكم
61 bearing block	قالب الحامل
62 tailstock	غراب الذيل
63 scanning head	رأس قرّز الألوان
64 copy cylinder	أسطوانة الأصل
65 centre (<i>Am.</i> center) bearing	محمل مركزي
66 engraving system	آلية الحفر
67 printing cylinder	أسطوانة الطبع
68 cylinder arm	ذراع الأسطوانة
69 electronics (electronic) cabinet	خبيزة الإلكترونيات
70 computers	أجهزة الكمبيوتر
71 program input	دخّل البرامج
72 automatic film processor for scanner films	وحدة معالجة آلية لأفلام جهاز قرّز الألوان (سكاند)
178 Electrotyping and Block Making	إعداد الأسطح الطباعية والمجلفنة والكلبيشيات
1-6 electrotyping plant	وحدة إعداد الأسطح الطباعية المجلفنة
1 cleaning tank	حوض تنظيف

2 rectifier	جهاز التصحيح
3 measuring and control unit	وحدة التحكم والقياس
4 electroplating tank (electroplating bath, electroplating vat)	حوض (مغطس) اللطاء بالكهرباء
5 anode rod (with copper anodes)	قضيب الأنود
6 plate rod (cathode)	قضيب الكاثود
7 hydraulic moulding (<i>Am.</i> molding) press	مكبس قولبة هيدرولي
8 pressure gauge (<i>Am.</i> gage) (manometer)	مقياس الضغط
9 apron	القورمة التي سيّسخ منها القالب
10 round base	قاعدة جسم المكبس المستديرة
11 hydraulic pressure pump	مضخة كبس هيدروليّة
12 drive motor	محرّك الإدارة
13 curved plate casting machine (curved electrotype casting machine)	مسبك المصببات المقوّسة
14 motor	المحرّك
15 control knobs	مفاتيح الضبط
16 pyrometer	مقياس درجات الحرارة العالية (بيرومتر)
17 mouth piece	فتحة تجويف الصب
18 core	غرفة الصب
19 melting furnace	فرن صهر سبيكة الرصاص
20 starting lever	ذراع التشغيل
21 cast curved plate (cast curved electrotype) for rotary printing	سطح طباعي مصبوب مقوّس للطباعة الدوّارة
22 fixed mould (<i>Am.</i> mold)	إطار ثابت للصب
23 etching machine	ماكينة حفر
24 etching tank with etching solution (etchant, mordant) and filming agent (film former)	حوض الحفر وبه مطول الحفر والمادة الفيلمية
25 paddles	عجلات قلابة
26 turntable	نضد دوار
27 plate clamp	قبضان تثبيت السطح الطباعي
28 drive motor	محرّك الإدارة
29 control unit	وحدة التحكم
30 twin etching machine	ماكينة حفر توأمية
31 etching tank (etching bath) [in section]	حوض الحفر [مقطع]
32 photoprinted zinc plate	السطح الطباعي المصنور
33 paddle	عجلة قلابة (إنتليب المطول)
34 outlet cock (drain cock, <i>Am.</i> faucet)	مكبس تصريف المطول
35 plate rack	حامل اللوح (السطح الطباعي)
36 control switches	مفاتيح التشغيل
37 lid	غطاء الحوض

38 half-tone photoengraving (half-tone block, half-tone plate), a block (plate, printing plate)	الخَطَر الفوتوغرافي للصورة الخطّية (قالب الهافتون)
39 dot (half-tone dot), a printing element	نقطة الشبكة الطباعية
40 etched zinc plate	لوح زنك محفور
41 block mount (block mounting, plate mount, plate mounting)	قاعدة الكلبيشه قاعدة (السطح الطباعي)
42 line block (line engraving, line cutting, line plate, line cut)	قالب (كلبيشه) خطّي حفر خطّي
43 non-printing, deep-etched areas	المناطق غير المطلوب طباعتها، حفر غائر
44 flange (bevel edge)	الحافة المائلة (بيزو)
45 sidewall	جدار جانبي
179 Offset Platemaking	تخصّير سطح طباعة الأوفست
1 plate whirler (whirler, plate-coating machine) for coating offset plates	جهاز تدوير (دوّار) لتغطية الأسطح المعدنية أو الرّجاجية بالمحاليل الضّخاسة للضوء
2 sliding lid	غطاء منزلق
3 electric heater	وحدة تسخين كهربائية
4 temperature gauge (<i>Am.</i> gage)	مقياس درجة الحرارة
5 water connection for the spray unit	توصيلة مياه وحدة الرش
6 spray unit	وحدة رش
7 hand spray	رشاش يدوي
8 plate clamps	قبضان تثبيت السطح الطباعي
9 zinc plate (<i>also:</i> magnesium plate, copper plate)	سطح طباعي (لوح) من الزنك (أيضاً من المغنيسيوم، النحاس)
10 control panel	لوحة تحكم
11 drive motor	محرّك الإدارة
12 brake pedal	دوّاسة المكبح
13 vacuum printing frame (vacuum frame, printing-down frame)	إطار طبع بالتفريغ
14 base of the vacuum printing frame (vacuum frame, printing-down frame)	قاعدة الإطار
15 plate glass frame	الإطار الزجاجي للوح
16 coated offset plate	لوح الأوفست المغطى بالمحلول الضخاس للضوء
17 control panel	لوحة التحكم
18 exposure timer	منظم التعريض للضوء
19 vacuum pump switches	مفاتيح تشغيل مضخة التفريغ
20 support	حامل
21 point light exposure lamp, ■ quartz-halogen lamp	مصباح كوارتز-هالوجين
22 fan blower	نافث المروحة

23 stripping table (make-up table) for stripping films	نضد تقطيع الأفلام (طاولة المونتاج)
24 crystal glass screen	لوح من الزجاج البلوري
25 light box	صندوق إضاءة
26 straightedge rules	مسطرة مستقيمة الحواف
27 vertical plate-drying cabinet	دولاب رأسي لتجفيف الألواح
28 hygrometer	هيجرومتر
29 speed control	مضبط السرعة
30 brake pedal	دوّاسة المكبح
31 processing machine for presensitized plates	ماكينة تضييق الألواح الضخاسة
32 burning-in oven for glue-enamel plates (diaz plates)	فرن ألواح الغراء والمينا (فرن ألواح الديازو)
33 control box (control unit)	وحدة التحكم
34 diazo plate	لوح الديازو
180 Offset Printing	طباعة الأوفست
1 four-colour (<i>Am.</i> four-color) rotary offset press (rotary offset machine, web-offset press)	ماكينة طباعة أوفست دوّارة أربعة ألوان (ماكينة طبع أوفست شريطي)
2 roll of unprinted paper (blank paper)	لفّة الورق غير المطبوع (الورق الأبيض)
3 reel stand (carrier for the roll of unprinted paper)	حامل لفّة الورق غير المطبوع
4 forwarding rolls	طُبّور سحب الورق
5 side margin control (margin control, side control, side lay control)	آلية التحكم في الهامش الجانبيين
6-13 inking units (inker units)	وحدات (أسطوانات) التحبير
6, 8, 10, 12 inking units (inker units) in the upper printing unit	وحدات (أسطوانات) التحبير في وحدة الطباعة العلوية
6-7 perfecting unit (double unit) for yellow	وحدة طبع على الوجهين للون الأصفر
7,9,11,13 inking units (inker units) in the lower printing unit	وحدات التحبير في وحدة الطباعة السفلية
8-9 perfecting unit (double unit) for cyan	وحدة طبع على الوجهين للون السيان
10-11 perfecting unit (double unit) for magenta	وحدة طبع على الوجهين للون الماجنتا
12-13 perfecting unit (double unit) for black	وحدة طبع على الوجهين للون الأسود
14 drier	وحدة التجفيف
15 folder (folder unit)	ماكينة الطي (تطبيق الورق)
16 control desk	نضد التحكم
17 sheet	فردق ورق
18 four-colour (<i>Am.</i> four-color) rotary offset	ماكينة طباعة أوفست دوّارة أربعة ألوان (ماكينة طبع

press (rotary offset machine, web-offset press) [diagram]	أوفست شريطي (رسم تخليطي)	50 inking rollers (ink rollers, inkers)	أَسْطُوَانَات التَّحْبِير
19 reel stand	حامل لَفَّة الورق	51 inking unit (inker unit)	وَحْدَة التَّحْبِير
20 side margin control (margin control, side control, side lay control)	آلية التحكم في الهامشَيْن الجانِبَيْن	52 damping rollers (dampening rollers, dampers, dampeners)	أَسْطُوَانَات التَّرْطِيب
21 inking rollers (ink rollers, inkers)	أَسْطُوَانَات التَّحْبِير (الْحَبْرَات)	53 plate cylinder, a zinc plate	مُتَبَوِّر السَّطْح المَلْبَاعِي
22 ink duct (ink fountain)	المحبرة (كَلْمَاءِيَة)	54 blanket cylinder, a steel cylinder with rubber blanket	مُتَبَوِّر الوَسِيط المَطَايِي (البِلَانِكْت)
23 damping rollers (dampening rollers, dampers, dampeners)	أَسْطُوَانَات التَّرْطِيب	55 pile delivery unit for the printed sheets	لوحَة سَحَب الأَفْرَاحِ المطبوعَة
24 blanket cylinder	مُتَبَوِّر الوَسِيط المَطَايِي (البِلَانِكْت)	56 gripper bar, a chain gripper	عَرِيَة قَطْع بِجَزِير
25 plate cylinder	مُتَبَوِّر السَّطْح المَلْبَاعِي	57 pile of printed paper (printed sheets)	رِصَّة الورقِ المطبوع (أَفْرَحِ مطبوعَة)
26 route of the paper (of the web)	مَسَارِ الورقِ/ شَرِيْطِي الورقِ	58 guard for the V-belt (vee-belt) drive	وقاء إِدَارَة السِير
27 drier	وَحْدَة التَّجْفِيف	59 single-colour (<i>Am.</i> single-color) offset press (offset machine) [diagram]	مَأْكِيَة طَبْع أَوْفَسْت لَوْنِ وَاحِد (رِيسْم تَخْلِيْطِي)
28 chilling rolls (cooling rollers, chill rollers)	وَحْدَة التَّجْفِيف	60 inking unit (inker unit) with inking rollers (ink rollers, inkers)	وَحْدَة التَّحْبِير وَمَعَهَا أَسْطُوَانَات التَّحْبِير
29 folder (folder unit)	مَأْكِيَة الطَّي (تَطْبِيقِ الورقِ)	61 damping unit (dampening unit) with damping rollers (dampening rollers, dampers, dampeners)	وَحْدَة التَّرْطِيب وَأَسْطُوَانَات التَّرْطِيب
30 four-colour (<i>Am.</i> four-color) sheet-fed offset machine (offset press) [diagram]	مَأْكِيَة طَبْع أَوْفَسْت أَرْبَعَة أَلْوَانِ بِأَفْرَاحِ [رِيسْم تَخْلِيْطِي]	62 plate cylinder	مُتَبَوِّر السَّطْح المَلْبَاعِي
31 sheet feeder (feeder)	مُعْذِي أَوْتوماتي بِأَفْرَاحِ الورقِ	63 blanket cylinder	مُتَبَوِّر البِلَانِكْت
32 feed table (feed board)	لَوْحَة تَلْقِيمِ أَفْرَاحِ الورقِ	64 impression cylinder	مُتَبَوِّر الطَّبِيعَة/ضَاغَط
33 route of the sheets through swing-grippers to the feed drum	مَسَارِ الورقِ عِبر قَوَابِضِ أَرْجُوْحِيَة إِلَى مُتَبَوِّر الإلْقَامِ	65 delivery cylinders with grippers	أَسْطُوَانَات سَحَبِ الورقِ المطبوع والْبِيْس
34 feed drum	مُتَبَوِّر الإلْقَامِ بِالورقِ	66 drive wheel	تَرَسِ الإِدَارَة
35 impression cylinder	مُتَبَوِّر الطَّبِيعَة/ضَاغَط (أَسْطُوَانَة الكَبْسَة) المُتَبَوِّرِ النَّاقلِ	67 feed table (feed board)	طَاوِلَة تَلْقِيمِ المَأْكِيَة بِأَفْرَاحِ الورقِ
36 transfer drums (transfer cylinders)	مُتَبَوِّر البِلَانِكْت	68 sheet feeder (feeder)	أَلِيَة تَلْقِيمِ المَأْكِيَة بِأَفْرَاحِ الورقِ
37 blank cylinder	مُتَبَوِّر السَّطْح المَلْبَاعِي	69 pile of unprinted paper (blank paper, unprinted sheets, blank sheets)	رِصَّة الورقِ الأَبْيَضِ غَيْرِ المطبوع
38 plate cylinder	وَحْدَة التَّرْطِيب	70 small sheet-fed offset press	مَأْكِيَة طَبْع أَوْفَسْت بِأَفْرَاحِ صَغِيرَة
39 damping unit (dampening unit)	وَحْدَة التَّحْبِير	71 inking unit (inker unit)	وَحْدَة التَّحْبِير
40 inking unit (inker unit)	وَحْدَة الطَّعْمِ	72 suction feeder	أَلِيَة تَلْقِيمِ شَفَاظَة
41 printing unit	أَسْطُوَانَة سَحَبِ الأَفْرَاحِ المطبوعَة	73 pile feeder	أَلِيَة تَلْقِيمِ أَفْرَاحِ الورقِ
42 delivery cylinder	سَحْبِ الأَفْرَاحِ المطبوعَة	74 instrument panel (control panel) with counter, pressure gauge (<i>Am.</i> gage), air regulator, and control switch for the sheet feeder (feeder)	لَوْحَة التَّحْكَمِ وَبِهَا العِدَادِ وَبِقِيَّاسِ الضَّغْطِ وَمُنْتَلَمِ الهَوَاءِ وَمِقْتَاَحِ التَّشْغِيلِ الخَاصَّة بِأَلِيَة التَّلْقِيمِ
43 chain delivery	رِصَّة الأَفْرَاحِ المطبوعَة	75 flat-bed offset press (offset machine)	مَأْكِيَة طَبْع جِثَارِبِ أَوْفَسْتِ ذاتِ نَحَاسَة مُسَطَّحَة
44 delivery pile	وَحْدَة سَحَبِ الأَفْرَاحِ المطبوعَة		
45 delivery unit (delivery mechanism)	مَأْكِيَة طَبْع أَوْفَسْت لَوْنِ وَاحِد		
46 single-colour (<i>Am.</i> single-color) offset press (offset machine)	رِصَّة الورقِ الأَبْيَضِ		
47 pile of paper (sheets, printing paper)	مُعْذِي أَوْتوماتي لِأَفْرَاحِ الورقِ		
48 sheet feeder (feeder), an automatic pile feeder	طَاوِلَة تَلْقِيمِ المَأْكِيَة بِأَفْرَاحِ الورقِ		
49 feed table (feed board)			

press, proof press)	وَحْدَة التَّحْبِير	joint action)	(فِعْل مَفْصَلِي)
76 inking unit (inker unit)	أَسْطُوَانَات التَّحْبِير	17 bed (type bed, press bed, forme bed, <i>Am.</i> form bed)	النَّحَاسَة (مَكَانِ الفُورْمَة)
77 inking rollers (ink rollers, inkers)	قَاعَة السَّطْح المَلْبَاعِي (النَّحَاسَة)	18 forme rollers (<i>Am.</i> form rollers) (forme-inking, <i>Am.</i> form-inking, rollers)	أَسْطُوَانَات تَحْبِيرِ النَّحَاسَة (شَلَنْدَرَاتِ الفُورْمَة)
78 bed (press bed, type bed, forme bed, <i>Am.</i> form bed)	مُتَبَوِّر بَوسِيطِ مَطَايِي نَاقِلِ (بِلَانِكْت)	19 inking unit (inker unit) for distributing the ink (printing ink)	وَحْدَة التَّحْبِيرِ الخَاصَّة بِتَوَزِيعِ حَبْرِ الطَّبِيعَة
79 cylinder with rubber blanket	ذِرَاعِ تَشْغِيلِ وَحْدَة الطَّبِيعَة	20 stop-cylinder press (stop-cylinder machine)	مَأْكِيَة طَبْع بِأَسْطُوَانَة إِيقَافِ
80 starting and stopping lever for the printing unit	عَجَلَة تَنْظِيمِ الضَّغْطِ	21 feed table (feed board)	طَاوِلَة تَغْذِيَة المَأْكِيَة بِالورقِ
81 impression-setting wheel (impression-adjusting wheel)		22 feeder mechanism (feeding apparatus, feeder)	أَلِيَة تَغْذِيَة المَأْكِيَة بِالورقِ
181 Letterpress Printing	طَرِيقَة طَبِيعَة الحُرُوفِ (النَّبِيعَة البَارِزَة)	23 pile of unprinted paper (blank paper, unprinted sheets, blank sheets)	رِصَّة الورقِ الأَبْيَضِ (غَيْرِ المطبوع)
1-65 presses (machines) for letterpress printing (letterpress printing machines)	مَأْكِيَات طَبِيعَة الحُرُوفِ (النَّبِيعَة البَارِزَة)	24 guard for the sheet feeder (feeder)	وقاء أَلِيَة التَّغْذِيَة بِالورقِ
1 two-revolution flat-bed cylinder press	مَأْكِيَة طَبِيعَة بِقَاعَة شَمْسُحَة ذاتِ دَوَرَتَيْنِ	25 pile of printed paper (printed sheets)	رِصَّة الورقِ المطبوع
2 impression cylinder	أَسْطُوَانَة الكَبْسَة	26 control mechanism	أَلِيَة التَّشْغِيلِ
3 lever for raising or lowering the cylinder	ذِرَاعِ رَفْعِ وَخَفْضِ الأَسْطُوَانَة	27 forme rollers (<i>Am.</i> form rollers) (forme-inking, <i>Am.</i> form-inking, rollers)	أَسْطُوَانَات تَحْبِيرِ النَّحَاسَة (شَلَنْدَرَاتِ الفُورْمَة)
4 feed table (feed board)	طَاوِلَة التَّغْذِيَة بِالورقِ	28 inking unit (inker unit)	وَحْدَة التَّحْبِيرِ
5 automatic sheet feeder (feeder) [operated by vacuum and air blasts]	وَحْدَة تَلْقِيمِ الورقِ أَلِيَا (مُعْذِي أَوْتوماتي لِأَفْرَاحِ الورقِ)	29 [Heidelberg] platen press (platen machine, platen)	مَأْكِيَة طَبِيعَة هَايْدِلْبِرْجِ بِكَابِسَة مُسَطَّحَة
6 air pump for the feeder and delivery	مُضَخَّة هَوَائِيَة لِتَشْغِيلِ وَحْدَة تَلْقِيمِ وَسَحْبِ الورقِ	30 feed table (feed board) with pile of unprinted paper (blank paper, unprinted sheets, blank sheets)	طَاوِلَة تَغْذِيَة المَأْكِيَة بِالورقِ وَعَلَيْهَا رِصَّةُ ورَقِ أَبْيَضِ غَيْرِ مطبوع
7 inking unit (inker unit) with distributing rollers (distributor rollers, distributors) and forme rollers (<i>Am.</i> form rollers)	وَحْدَة التَّحْبِيرِ أَسْطُوَانَاتِ تَوَزِيعِ الحَبْرِ وَالنَّحَاسَة	31 delivery table	طَاوِلَة سَحَبِ الورقِ
8 ink slab (ink plate) inking unit (inker unit)	وَحْدَة التَّحْبِيرِ	32 starting and stopping lever	ذِرَاعِ التَّشْغِيلِ وَالإيقَافِ
9 delivery pile for printed paper	رِصَّة الورقِ المطبوع	33 delivery blower	نَافِخِ سَحَبِ الورقِ
10 sprayer (anti set-off apparatus, anti set-off spray) for dusting the printed sheets	رَشَاشِ لِتَعْفِيرِ الأَفْرَاحِ المطبوعَة	34 spray gun (sprayer)	رَشَاشِ
11 interleaving device	جِهَازِ الأَفْرَاحِ البَيْنِيَّةِ	35 air pump for vacuum and air blasts	مُضَخَّة هَوَائِيَة لِدَفْعِ الهَوَاءِ
12 foot pedal for starting and stopping the press	دَوَّاسَة القَدَمِ لِتَشْغِيلِ وَإيقَافِ المَأْكِيَة	36 locked-up forme (<i>Am.</i> form) (شَاسِيَة)	فُورْمَة مَرْبُوطَة فِي طُوقِ (شَاسِيَة)
13 platen press (platen machine, platen) [in section]	مَأْكِيَة طَبْع بِكَابِسَة مُسَطَّحَة [مَقْطَع]	37 type (type matter, matter)	الْمَصْفَحَاتِ المَجْمُوعَة
14 paper feed and delivery (paper feeding and delivery unit)	وَحْدَة تَغْذِيَة المَأْكِيَة بِالورقِ وَسَحْبِهِ بَعْدِ الطَّبِيعَة	38 chase	الشَاسِيَة
15 platen	الكَبْسَة	39 quoin	قَفْلِ رِبْطِ المَصْفَحَاتِ فِي الطُوقِ (سِجَّيَة)
16 toggle action (toggle-	اتِّجَاهِ الكَبْسَة ذَهَابًا وَجِيئَة	40 length of furniture	مَوَادِ مَالِيَّة (تَوَاصِيْبِ دُرُقَانِقِ)
		41 rotary letterpress press (rotary letterpress machine, web-fed	مَأْكِيَة طَبْعِ الجِرائِدِ حَتَّى 16 صَفْحَة (مَأْكِيَة طَبِيعَة حُرُوفِ دَوَّارَة)

صناديق التغليف بالكرتون
شفاطات الكرتون
حَلّة الغراء (حَلّة)
أَسْطُوَانَة تغرية
رأس اللاقط بجهاز النفط
طاولة التغذية بمواد
التغليف [كُتَاب، ورق، جلد]

7 board feed hoppers
8 pick-up suckers
9 glue tank
10 cover cylinder
11 picker head
12 feed table for covering materials [linen, paper, leather]
13 pressing mechanism
14 delivery table
15 gang stitcher (gathering and wire-stitching machine, gatherer and wire stitcher)
16 sheet feeder (sheet-feeding station)
17 folder-feeding station
18 stitching wire feed mechanism
19 delivery table
20 rotary board cutter (rotary board-cutting machine)
21 feed table with cut-out section
22 rotary cutter
23 feed guide

آليّة الكبس
لَوْحَة استقبال الأغلفة
الجاهزة
ماكينة تجميع وتدبيس
(خزّم) الملازم
منحطة التلقيم
منحطة تلقيم جهاز الطّي
آليّة التدبّيس (ردّوس
التدبّيس، الخَزَام)
طاولة استقبال الملازم
المدبّسة
ماكينة قَطْع أفرخ دوّارة
طاولة التغذية بأفرخ الورق
مقص دوّار
دليل التغذية

185 Bookbinding III 1-35 bookbinding machines

1 guillotine (guillotine cutter, automatic guillotine cutter)
2 control panel
3 clamp
4 back gauge (*Am. gage*)
5 calibrated pressure adjustment [to clamp]
6 illuminated cutting scale
7 single-hand control for the back gauge (*Am. gage*)
8 combined buckle and knife folding machine (combined buckle and knife folder)
9 feed table (feed board)
10 fold plates
11 stop for making the buckle fold
12 cross fold knives
13 belt delivery for parallel-folded

تجليد الكُتَب (3)
ماكينات تجليد الكُتَب
مِقْص جيلوتين قَطْع الورق
لَوْحَة التشغيل والتحكم
كَمْرَة قَمَط
مُحَدّد قياس الفص (زاوية
خلفية)
مُقْيَاس ضغط (عيار) ضغط
القائمة
مُقْيَاس قص مَضَاء
مِقْبَض ضبط الزاوية
الخلفية
ماكينة طي (ماكينة تطبيق)
طاولة تلقيم الأفرخ
شبابيك الطّي
مسطرة لضبط عيار الطّيّة
الأولي
أسلحة الطّيّة العَرْضِيّة
(المتعامدة)
وَحْدَة استقبال الملازم
المطوّبة بطيات متوازية

مَسْنَد تقطيع ورق الذهب
سكين تقطيع ورق الذهب
خِيَاطة الملازم
إطار خياطة الملازم
(الشُدّة) يدويّاً
دوْبَارَة (خيطة) خِيَاطة
بِكْرَة خَيْط
مَلْمَمَة من الكُتَاب مَعْدَة
للخياطة
سكين المَحْدّد
تغرية كَعْب الكُتَاب
إِنَاء الغراء
سكينة كرتون (مقص
كرتون)
مُحَدّد قياس القمص (زاوية
خلفية)
قاسطة تعمل يدوياً
مَضَلّ سكين القطع
ماكينة قَمَط الملازم القائمة
كثلة الرأس
محور دوران
دولاب يدوي
كاسية مسطحة
قاعدة
ماكينة تذهيب ويضم بارز

صندوق التسخين
لَوْح مَزَلِق
لَوْح الضّم البارز
اتجاه الكيسه ذهاباً ورجوعاً
ذراع يدوي
كُتَاب مَخِيط على الشاشة
(كُتَاب غير مُجَدّد)
شاش
خياطة
شريط الرأس (حِكْة
الرأس)

تجليد الكُتَب (2) ماكينات تجليد الكُتَب

ماكينة تجليد بالبلاستيك
(ماكينة تجليد كامل)
وَحْدَة التلقيم اليدوي
سكين القطع ووحدة التجهيز
الأولي
آليّة التغرية
سحب الكُتَاب
ماكينة صنع الأغلفة
(الجلّطات)

6 gold cushion
7 gold knife
8 sewing (stitching)
9 sewing frame
10 sewing cord
11 ball of thread (sewing thread)
12 section (signature)
13 bookbinder's knife
14 gluing the spine
15 glue pot
16 board cutter (guillotine)
17 back gauge (*Am. gage*)
18 clamp with foot pedal
19 cutting blade
20 standing press, a nipping press
21 head piece (head beam)
22 spindle
23 handwheel
24 platen
25 bod (base)
26 gilding (gold blocking) and embossing press, a hand-lever press; *sim. toggle-joint press* (toggle-lever press)
27 heating box
28 sliding plate
29 embossing platen
30 toggle action (toggle-joint action)
31 hand lever
32 book sewn on gauze (mull, scrim) (book block)
33 gauze (mull, scrim)
34 sewing (stitching)
35 headband

184 Bookbinding II 1-23 bookbinding machines

1 adhesive binder (perfect binder) for short runs
2 manual feed station
3 cutoff knife and roughing station
4 gluing mechanism
5 delivery (book delivery)
6 case maker (case-making machine)

أَسْطُوَانَة نحاسية مصقولة
مُطَبّر مطاطي للضغط على
الورق المصنّع المطبوع
ماكينة طبع ببطنور ضاغط
مُطَبّر طبع غائر مَعْطَى
بطبقة من الورق المَصْنِيعِ
خَوْص الإظْهَار
مرحلة
أَسْطُوَانَة مَطْهَرَة
عامل التذهيب يقوم بعمل
الروتش
ماكينة حَفْر
خَوْص حَفْر به مطول
الحفر
أَسْطُوَانَة طبع غائر مطبوعة
عامل ماكينة طبع من سَطْح
غائر
قَرص حاسب
جهاز توقيت
تصحيح الأَسْطُوَانَة

أَسْطُوَانَة طبع غائر مَحْفُورَة
رَف
ماكينة طبع غائر شريطي
متعددة الألوان (ماكينة
الفوتوغرافياور)
ماسورة تصريف البخيرة
المدبّيات المتطايرة
وَحْدَة طباعة يمين ويسار
جهاز الطّي
مِنْضَدَة التشغيل والتحكم
وَحْدَة سحب الجرائد

سَيْر ناقل
رَضَة من الجرائد

تجليد الكُتَب (1) تجليد الكُتَب يدويّاً

تذهيب كَعْب الكُتَاب
عامل التذهيب
شُرَيْط
مِكْس تثبيت
ورقة ذهب

machine (laydown machine, laying machine)
7 polished copper cylinder
8 rubber roller for pressing on the printed carbon tissue (pigment paper)
9 cylinder-processing machine
10 gravure cylinder coated with carbon tissue (pigment paper)
11 developing tank
12 staging
13 developed cylinder
14 retoucher painting out (stopping out)
15 etching machine
16 etching tank with etching solution (etchant, mordant)
17 printed gravure cylinder
18 gravure etcher
19 calculator dial
20 timer
21 revising (correcting) the cylinder
22 etched gravure cylinder
23 ledge
24 multicolour (*Am. multicolor*) rotogravure press
25 exhaust pipe for solvent fumes
26 reversible printing unit
27 folder (folder unit)
28 control desk
29 newspaper delivery unit
30 conveyor belt (conveyor)
31 bundled stack of newspapers

183 Bookbinding I 1-35 hand bookbinding (hand bindery)

1 gilding the spine of the book
2 gold finisher (gilder), a bookbinder
3 fillet
4 holding press (finishing press)
5 gold leaf

letterpress machine) for newspapers of up to 16 pages
42 slitters for dividing the width of the web
43 web
44 impression cylinder
45 jockey roller (compensating roller, compensator, tension roller)
46 roll of paper
47 automatic brake
48 first printing unit
49 perfecting unit
50 inking unit (inker unit)
51 plate cylinder
52 second printing unit
53 former
54 tachometer with sheet counter
55 folder (folder unit)
56 folded newspaper
57 inking unit (inker unit) for the rotary press (web-fed press) [in section]
58 web
59 impression cylinder
60 plate cylinder
61 forme rollers (*Am. form rollers*) (forme-inking, *Am. form-inking*, rollers)
62 distributing rollers (distributor rollers, distributors)
63 lifter roller (ductor, ductor roller)
64 duct roller (fountain roller, ink fountain roller)
65 ink duct (ink fountain)

182 Photogravure (Gravure Printing, Intaglio Printing)

1 exposure of the carbon tissue (pigment paper)
2 vacuum frame
3 exposing lamp, a bank of quartz-halogen lamps
4 point source lamp
5 heat extractor
6 carbon tissue transfer

signatures	وَحْدَةُ العِمَّةِ الثالثة (طية)
14 third cross fold unit	عَرْضِيَّة)
15 delivery tray for cross-folded signatures	صندوق استقبال العَمَلَامِ المطوية بطَيَّات عَرْضِيَّة (متعامدة)
16 sewing machine (book-sewing machine)	مَأْكِنَةٌ خِيَّاطَةٌ
17 spool holder	حَامِلُ بَكَرَات الخَيْطِ
18 thread cop (thread spool)	بَكَرَةٌ خَيْطٍ مَخْرُوطِيَّة الشكل
19 gauze roll holder (mull roll holder, scrim roll holder)	حَامِلُ بَكَرَةِ الشَّاشِ (حَامِلُ بَكَرَةٍ من نَسِجٍ شَفَافٍ)
20 gauze (mull, scrim)	شَاشٌ أَوْ نَسِجٌ شَفَافٌ لِدَعْمِ كَعَبِ الكِتَابِ
21 needle cylinders with sewing needles	سَسَاكَاتُ إِبْرِ الخِيَّاطَةِ
22 sewn book	كِتَابٌ بِمِلازِمٍ مَخِيَّطَةٌ
23 delivery	صَنِيبَةٌ رَضَنَ الكَعْبِ المَخِيَّطَةِ
24 reciprocating saddle	حَامِلٌ (حَصَانٍ) التَّقْلِيمِ بِالْمِلازِمِ
25 sheet feeder (feeder)	أَلْيَةٌ التَّقْلِيمِ
26 feed hopper	كَرْتُونٌ التَغْذِيَّةِ
27 casing-in machine	مَأْكِنَةٌ تَلْبِيسِ الشَّخْطَةِ
28 joint and side pasting attachment	أَلْيَةٌ التَغْرِيبَةِ
29 blade	سِلَاحٌ لِحَمَلِ الكِتَابِ
30 preheater unit	وَحْدَةُ التَسْخِينِ الأَوَّلِي
31 gluing machine for whole-surface, stencil, edge, and strip gluing	مَأْكِنَةٌ تَصْمِيعِ السَطْحِ بِالكَامِلِ وَالاسْتِثْنَالِ وَالحَافَةِ وَالشَّرَاطِ
32 glue tank	خِزَانٌ المِصْعِ
33 glue roller	أَسْطُوَانَةٌ التَصْمِيعِ
34 feed table	طَاوَلَةٌ التَغْذِيَّةِ
35 delivery	طَاوَلَةٌ اسْتِقبَالِ
36 book	كِتَابٌ
37 dust jacket (dust cover, book jacket, wrapper)	سِتْرَةٌ الكِتَابِ (جَاكَتٌ)
38 jacket flap	لِسَانُ السِتْرِ/الجَاكَتِ
39 blurb	تَعْرِيفٌ بِالكِتَابِ (تَوْبَهُ)
40-42 binding	التَّغْلِيفُ
40 cover (book cover, case)	غِلَافٌ/جِلْدَةٌ الكِتَابِ
41 spine (backbone, back)	كَعْبُ الكِتَابِ
42 tailband (footband)	حِكْمَةٌ ذَيْلُ كَعْبِ الكِتَابِ
43-47 preliminary matter (prelims, front matter)	المَادَّةُ التَّهْجِيدِيَّةُ
43 half-title	صَفْحَةٌ العُنْوَانِ المَخْتَصِرِ
44 half-title (bastard title, fly title)	عُنْوَانٌ مَخْتَصِرٌ لِّلْكِتَابِ
45 title page	صَفْحَةٌ عُنْوَانِ الكِتَابِ (العُنْوَانُ الدَّاخِلِي)
46 full title (main title)	العُنْوَانُ الرَّئِيسِي لِّلْكِتَابِ
47 subtitle	عُنْوَانٌ ثَانَوِي
48 publisher's imprint (imprint)	شِعَارُ النَّاشِرِ

49 fly leaf (endpaper, endleaf)	بَطَّانَةُ الكِتَابِ
50 handwritten dedication	إِهْدَاءٌ بِخَطِّ اليَدِ
51 bookplate (ex libris)	بَطَّاقَةٌ مِلْكِيَّةُ الكِتَابِ
52 open book	كِتَابٌ مَفْتُوحٌ
53 page	صَفْحَةٌ مَطْبُوعَةٌ
54 fold	طَيَّةٌ (ثَنِيَّةٌ)
55-58 margin	هَامِشٌ دَاخِلِي
55 back margin (inside margin, gutter)	هَامِشٌ علَوِي (هَامِشُ الرَّأْسِ)
56 head margin (upper margin)	هَامِشٌ خَارِجِي (جَانِبِي)
57 fore edge margin (outside margin, fore edge)	هَامِشٌ سَفْلِي (هَامِشُ الذَيْلِ)
58 tail margin (foot margin, tail, foot)	مَنْطِقَةٌ جَمْعُ (النَّصِ)
59 type area	عُنْوَانُ الفَصْلِ أَوْ البَابِ
60 chapter heading	نَجْمَةٌ أَوْ عِلَامَةٌ إِحَالَةٌ إِلَى مَرْجِعٍ
61 asterisk	مِلَاحِظَةٌ أَوْ حَاشِيَّةٌ بِهَامِشِ الذَيْلِ
62 footnote	رَقْمُ الصَّفْحَةِ
63 page number	جَمْعٌ عَلَى عُنُودَيْنِ
64 double-column page	عُنُودٌ جَمْعٌ
65 column	عُنْوَانٌ مُتَكَرِّرٌ (سَيَّارٌ)
66 running title (running head)	عُنْوَانٌ مُتَكَرِّرٌ ثَانَوِي
67 caption	مِلَاحِظَةٌ فِي الهَامِشِ الخَارِجِي (جَانِبِي)
68 marginal note (side note)	عِلَامَةٌ تَسْلِسِلُ المَلَزِمَةَ
69 signature (signature code)	شَرِيْطٌ لِتَحْدِيدِ الصَّفْحَةِ فِي الكِتَابِ
70 attached bookmark (attached bookmarker)	جِدَائِدَةٌ لِتَحْدِيدِ الصَّفْحَةِ فِي الكِتَابِ
71 loose bookmark (loose bookmarker)	

186 Horse-drawn Carriages

1-54 carriages (horse-drawn vehicles)	عَرَبَاتٌ تَجْرُهَا الجِيَادُ
1-3, 26-39, 45, 51-54 carriages and coaches (coach wagons)	عَرَبَاتٌ وَحَافِلَاتٌ
1 berlin	عَرَبِيَّةُ البَرْلِينِيَّةِ
2 wagonette; larger: brake (break)	عَرَبِيَّةٌ خَفِيفَةٌ (الأَكْبَرُ حِجْمًا البَرِيكِيَّةُ)
3 coupé; sim.: brougham	عَرَبِيَّةُ الكُوْبِيَّةِ (البَرَّهَامُ)
4 front wheel	عَجَلَةٌ أَمَامِيَّةٌ
5 coach body	جِسْمُ الحَافِلَةِ (العَرَبِيَّةِ)
6 dashboard (splash-board)	الحَاجِيَّةُ (وَقَاءٌ مِنَ المَاءِ وَالوَحْلِ)
7 footboard	مَسَدٌ قَدَمِيّ الحَوْدِيّ
8 coach box (box, coachman's seat, driver's seat)	مَقْعَدُ الحَوْدِيّ
9 lamp (lantern)	مِصْبَاحٌ (فَانُوسٌ)
10 window	نَافِذَةٌ
11 door (coach door)	بَابُ الحَافِلَةِ

12 door handle (handle)	مِقْبَضُ البَابِ
13 footboard (carriage step, coach step, step, footpiece)	مَوَطِيّ العَرَبِيَّةِ
14 fixed top	سَقْفٌ ثَابِتٌ
15 spring	نَابِضٌ، سَوْسَةٌ
16 brake (brake block)	مَكْبَعٌ، فَرْمَلَةٌ
17 back wheel (rear wheel)	عَجَلَةٌ خَلْفِيَّةٌ
18 dogcart, a one-horse carriage	عَرَبِيَّةُ الكَلْبِيَّةِ
19 shafts (thills, poles)	عَرِيشُ العَرَبِيَّةِ
20 lackey (lacquey, footman)	خَادِمٌ يَرْتَدِي بَرَّةً خَاصَةً (المِعْبُورِ)
21 livery	بَرَّةُ الخَادِمِ
22 braided (gallooned) collar	يَاقَةُ مَرَّكَسَةٍ
23 braided (gallooned) coat	مِعْطَفٌ مَرَّكَسٌ
24 braided (gallooned) sleeve	كُمٌ مَرَّكَسٌ
25 top hat	قَبْعَةٌ مَرْتَفِعَةٌ
26 hackney carriage (hackney coach, cab, growler, Am. hack)	عَرَبِيَّةُ أَجْرَةٍ
27 stableman (groom)	عَامِلُ الإِسْطَبَلِ
28 coach horse (carriage horse, cab horse, thill horse, thiller)	حِصَانٌ جِزُّ العَرَبِيَّةِ
29 hansom cab (hansom), a cabriolet, a one-horse chaise (one-horse carriage)	عَرَبِيَّةُ الهَسْمَانِيَّةِ، عَرَبِيَّةٌ يَجْرُهَا حِصَانٌ وَاحِدٌ
30 shafts (thills, poles)	عَرِيشُ العَرَبِيَّةِ
31 reins (rein, Am. line)	العِصَانُ (اللِجَامُ)
32 coachman (driver) with inverness	سَائِقُ العَرَبِيَّةِ يَرْتَدِي الأَنْفَرْتَانِسِيَّةَ
33 covered char-a-banc (brake, break), a pleasure vehicle	أَوْتوبُوسٌ لِلتَّنَزُّهِ وَالتَّجَوُّلِ
34 gig (chaise)	عَرَبِيَّةٌ خَفِيفَةٌ يَجْرُهَا حِصَانٌ وَاحِدٌ (عَرَبِيَّةُ الشَّيْزِ)
35 barouche	عَرَبِيَّةُ البَرُوشَةِ
36 landau, a two-horse carriage; sim.: landaulet, landalette	عَرَبِيَّةُ اللَنْدَاوِيَّةِ
37 omnibus (horse-drawn omnibus)	عَرَبِيَّةُ الأَوْتِيبُوسِ
38 phaeton	عَرَبِيَّةُ الفَيْتُونِ
39 Continental stage-coach (mailcoach, diligence); also: road coach	مَرَّكَبَةٌ جِيَادٌ عَمُومِيَّةٌ لِلسَّفَرِ
40 mailcoach driver	حَوْدِيّ عَرَبِيَّةِ البَرِيدِ
41 posthorn	بُوقُ البَرِيدِ
42 hood	غِطَاءُ العَرَبِيَّةِ
43 post horses (relay horses, relays)	جِيَادٌ عَرَبِيَّةُ البَرِيدِ
44 tilbury	التَّيْبُرِيَّةُ

45 troika (Russian three-horse carriage)	عَرَبِيَّةُ التَّرْيُوكَا (عَرَبِيَّةٌ رُوسِيَّةٌ يَجْرُهَا ثَلَاثَةُ جِيَادٍ الجَوَادِ المَقْدَمِ)
46 leader (wheel horse, pole horse)	جَوَادُ العَجَلَةِ
47 wheeler (wheel horse, pole horse)	عَرَبِيَّةُ البُوجِيَّةِ الإِنْجِلِيزِيَّةِ
48 English buggy	عَرَبِيَّةُ البُوجِيَّةِ الأَمْرِيكِيَّةِ
49 American buggy	عَرَبِيَّةُ التَّنْدَمِ
50 tandem	عَرَبِيَّةٌ مَقَاعِدُهَا مُتَقَابِلَةٌ
51 vis-à-vis	سَقْفٌ مُتَحَرِّكٌ
52 collapsible hood (collapsible top)	عَرَبِيَّةُ البَرِيدِ
53 mailcoach (English stagecoach)	عَرَبِيَّةٌ شَيْزٌ مُنْطَهَةٌ
54 covered (closed) chaise	

187 Bicycle

1 bicycle (cycle, coll. bike, Am. wheel), a gent's bicycle, a touring bicycle (touring cycle, roadster)	الدَّرَاجَةُ الهَوَائِيَّةُ الدَّرَاجَةُ الهَوَائِيَّةُ
2 handlebar (handlebars), a touring cycle handlebar	مِقْوَدُ الدَّرَاجَةِ
3 handlebar grip (hand-grip, grip)	قَبْضَةُ مِقْوَدِ الدَّرَاجَةِ
4 bicycle bell	جِرْسُ الدَّرَاجَةِ
5 hand brake (front brake), a rim brake	فَرْمَلَةٌ يَدَوِيَّةٌ، فَرْمَلَةٌ أَمَامِيَّةٌ
6 lamp bracket	حَامِلُ المِصْبَاحِ
7 headlamp (bicycle lamp)	مِصْبَاحُ الدَّرَاجَةِ الأَمَامِي
8 dynamo	المُؤَلِّدُ (الدِينَامُو)
9 pulley	بَكَرَةٌ
10-12 front forks	الشَّعْبَعَاتُ الأَمَامِيَّةُ
10 handlebar stem	عَمُودُ مِقْوَدِ الدَّرَاجَةِ
11 steering head	رَأْسُ التَّوَجُّهِ
12 fork blades (fork ends)	أَطْرَافُ الشَّعْبَعَةِ
13 front mudguard (Am. front fender)	وَقَاءُ الوَحْلِ الأَمَامِي
14-20 bicycle frame	إِطَارُ (جِسْمُ) الدَّرَاجَةِ
14 steering tube (fork column)	أَنْبُوبُ التَّوَجُّهِ (عَمُودُ الشَّعْبَعَةِ)
15 head badge	عِلَامَةٌ أَمَامِيَّةٌ
16 crossbar (top tube)	قَضِيبٌ مُشْتَغَرَضٌ
17 down tube	أَنْبُوبٌ نَازِلٌ
18 seat tube	أَنْبُوبُ المَقْعَدِ
19 seat stays	دَعَامَتَا حَمْلِ المَقْعَدِ
20 chain stays	دَعَامَتَا السَّلْسِلَةِ
21 child's seat (child carrier seat)	مَقْعَدٌ لِحَمْلِ طِفْلِ
22 bicycle saddle	سَرِجٌ (مَقْعَدٌ) الدَّرَاجَةِ
23 saddle springs	نَوَابِضُ سَرِجٍ (مَقْعَدِ) الدَّرَاجَةِ
24 seat pillar	عَمُودُ المَقْعَدِ
25 tool bag	صندوقُ الأَدْوَاتِ
26-32 wheel (front wheel)	العَجَلَةُ (العَجَلَةُ الأَمَامِيَّةُ)
26 hub	قَبُّ العَجَلَةِ

27 spoke	شعاع العجلة	back-pedal brake (with coaster brake)	بدواسة خلفية
28 rim (wheel rim)	الحافة (حافة العجلة)	24 safety nut	صامولة أمان
29 spoke nipple (spoke flange, spoke end)	طُرْف الشعاع	65 lubricator	مشحمة
30 tyre (<i>Am.</i> tire) (pneumatic tyre, high-pressure tyre); <i>inside</i> : tube (inner tube), <i>outside</i> : tyre (outer case, cover)	الإطار [إطار مملوء بالهواء المضغوط] (من الداخل أنبوب، من الخارج غلاف من المطاط)	66 brake arm	ذراع الفرملة
31 valve, a tube valve with valve tube or a patent valve with ball	بَلْف، صمام	67 brake arm cone	مخروط ذراع الفرملة
32 valve sealing cap	غطاء إحكام البلف	68 bearing cup with ball bearings in ball race	حَقّ المحمّل وبه حامل كُرَيَات في مَدْرَجَة كُرَيَات غلاف القَبّ
33 bicycle speedometer with milometer	عداد سُرْعَة الدَّرَاجَة وعداد المسافة	69 hub shell (hub body, hub barrel)	صندوق الفرملة
34 kick stand (prop stand)	مِسْنَد للدَّرَاجَة	70 brake casing	مخروط الفرملة
35-42 bicycle drive (chain drive)	إدارة (سلسلة/ جِزْزِير دفع) الدَّرَاجَة	71 brake cone	مخروط الفرملة
35-39 chain transmission	نقل الحركة	72 driver	أداة تدوير/دفع
35 chain wheel	بالسلسلة/ بالجِزْزِير	73 driving barrel	أسطوانة الدفع
36 chain, a roller chain	سلسلة (جِزْزِير)	74 sprocket	قرص مسنّن
37 chain guard	وقاء السلسلة/ الجِزْزِير	75 thread head	رأس سن اللولب
38 sprocket wheel (sprocket)	قرص مسنّن	76 axle	محور
39 wing nut (fly nut, butterfly nut)	صامولة مُخَنجة	77 bracket	كتيبة
40 pedal	دواسة (بِدَال)	78 bicycle pedal (pedal, reflector pedal)	دواسة (بِدَال) الدَّرَاجَة
41 crank	ذراع تدوير	79 cup	حَقّ
42 bottom bracket bearing	محمّل الكتيبة السفليّ	80 spindle	محور دَوْرَان
43 rear mudguard (<i>Am.</i> rear fender)	وقاء الوَحْل الخلفي	81 axle	محور
44 luggage carrier (carrier)	مِسْنَد الأمتعة (حامل)	82 dust cap	غطاء واقٍ من الأتربة
45 reflector	عاكس للنضوء	83 pedal frame	إطار البدواسة
46 rear light (rear lamp)	مصباح خلفي	84 rubber stud	وتد مطاطي
47 footrest	مِسْنَد القدم	85 rubber block (rubber tread)	كتلة مطاطية
48 bicycle pump	منفاخ الدَّرَاجَة	86 glass reflector	عاكس زجاجي
49 bicycle lock, a wheel lock	قفل عجلة الدَّرَاجَة		
50 patent key	مفتاح مسطح		
51 cycle serial number (factory number, frame number)	رقم مسلسل الدَّرَاجَة	188 Motorcycles, Bicycles, Scooters, Mopeds	الدَّرَاجَات النارية، الدراجات الهوائية، الدراجات النارية الخفيفة
52 front hub (front hub assembly)	مجموعة القَبّ الأمامي	1 folding bicycle	دَّرَاجَة قابلة للطيّ
53 wheel nut	صامولة تثبيت العجلة	2 hinge (<i>also</i> : locking lever)	مِفصّلة التوصل
54 locknut (locking nut)	صامولة زَنْق	3 adjustable handlebar (handlebars)	مَقْوَد قابل للتعديل
55 washer (slotted cone adjusting washer)	وردة/ حلقة لإحكام الربط	4 adjustable saddle	سَرَج (مَقْعَد) قابل للتعديل
56 ball bearing	محمّل كُرَيَات	5 stabilizers	عِجَلَات تثبيت للتوازن
57 dust cap	غطاء واقٍ من الأتربة	6 motor-assisted bicycle	دَّرَاجَة بمخَرَك مساعد
58 cone (adjusting cone)	مخروط	7 air-cooled two-stroke engine	مخَرَك تبريد هواء ثنائي الأشواط
59 centre (<i>Am.</i> center) hub	القَبّ المركزيّ	8 telescopic forks	شوكات تليسكوبية
60 spindle	محور دَوْرَان	9 tubular frame	إطار أنبوبي
61 axle	محور	10 fuel tank (petrol tank, <i>Am.</i> gasoline tank)	خَزَان الوقود
62 clip covering lubrication hole (lubricator)	مشبك تغطية المشحمة	11 semi-rise handlebars	مَقْوَد شبه قائم
63 free-wheel hub with	قَبّ دولاب حرّ ذو فرملة	12 two-speed gear-change (gearshift)	آليّة نقل تروس ذات سرعتين

19 speedometer (<i>coll.</i> speedo)	عداد السرعة	55 foot gear-change control (foot gearshift control)	آليّة نقل السرعة بالقدم
20 battery-powered moped, an electrically-powered vehicle	دَّرَاجَة تعمل بالبطارية	56 high-riser, <i>sim.</i> : Chopper	دَّرَاجَة مرتفعة المَقْوَد
21 swivel saddle	مَقْعَد دَوَار	57 high-rise handlebar (handlebars)	مَقْوَد مرتفع
22 battery compartment	خِجِيْرَة البطارية	58 imitation motorcycle fork	شوكَة شبيهة بشوكَة الدَّرَاجَة النارية
23 wire basket	سلة سلكيّة	59 banana saddle	سَرَج (مَقْعَد) على شكل موزة
24 touring motor (moped)	دَّرَاجَة بمخَرَك صغير للترتزه	60 chrome bracket	كتيبة من الكروم
25 pedal crank (pedal drive, starter pedal)	دواسة بدء التشغيل		
26 single-cylinder two-stroke engine	مخَرَك ثنائي الأشواط ذو أسطوانة واحدة	189 Motorcycle	الدَّرَاجَة النارية
27 spark-plug cap	غطاء شمعة الشرر (غطاء البوجيه)	1 lightweight motorcycle (light motorcycle) [50 cc]	دَّرَاجَة نارية خفيفة الوزن [50 سي سي]
28 fuel tank (petrol tank, <i>Am.</i> gasoline tank)	خَزَان الوقود	2 fuel tank (petrol tank, <i>Am.</i> gasoline tank)	خَزَان الوقود
29 moped headlamp (front lamp)	مصباح أمامي	3 air-cooled single-cylinder four-stroke engine (with overhead camshaft)	مخَرَك تبريد هواء رباعيّ الأشواط ذو أسطوانة واحدة (مع عمود كامّة علوي)
30-35 handlebar fittings	تركيبات المَقْوَد	4 carburettor (<i>Am.</i> carburetor)	أنبوب السحب
30 twist grip throttle control (throttle twist grip)	مِقْبَض التحكم في صمام الاختناق	5 intake pipe	صندوق تروس ذو خمس سرعات
31 twist grip (gear-change, gearshift)	مِقْبَض تغيير السرعة	6 five-speed gearbox	شوكَة خلفية ذات ذراع تارنجي
32 clutch lever	ذراع القابض	7 swinging-arm rear fork	شوكَة خلفية ذات ذراع لُوحة الرقم
33 hand brake lever	ذراع الفرملة اليدوية	8 number plate (<i>Am.</i> license plate)	المصباح الخلفي ومصباح التوقف (مصباح المؤخرة)
34 speedometer (<i>coll.</i> speedo)	عداد السرعة	9 stop and tail light (rear light)	المصباح الأمامي
35 rear-view mirror (mirror)	مرآة الرؤية الخلفية	10 headlight (headlamp)	فرملة أنطوانية أمامية
36 front wheel drum brake (drum brake)	الفرملة الأسطوانية للعجلة الأمامية	11 front drum brake	كيبيل الفرملة
37 Bowden cables (brake cables)	كيبيلات الفرملة	12 brake cable (brake line), a Bowden cable	فرملة أسطوانية خلفية
38 stop and tail light unit	وحدة المصابيح الخلفية ومصباح التوقف	13 rear drum brake	مَقْعَد مَرْدُوج
39 light motorcycle with kickstarter	دَّرَاجَة نارية خفيفة بآليّة بدء تشغيل تعمل بالقدم	14 racing-style twin seat	ماسورة عادم مُصعدّة
40 housing for instruments with speedometer and electronic rev counter (revolution counter)	شبيط الآلات مع عداد السرعة وعداد اللفات الإلكتروني	15 upswept exhaust	دَّرَاجَة نارية خفيفة للطرق الوعرة [125 سي سي]
41 telescopic shock absorber	ممتصّ صدمات تليسكوبيّ	16 scrambling motorcycle (cross-country motorcycle) [125 cc], a light motorcycle	إطار حامل خفيف الوزن
42 twin seat	مَقْعَد مَرْدُوج	17 lightweight cradle frame	لُوحة الرقم
43 kickstarter	آليّة بدء التشغيل بالقدم	18 number disc (disk)	مَقْعَد مَرْدُوج
44 pillion footrest, a footrest	مِسْنَد قَدَمَيْنِ للراكب الخلفي	19 solo seat	ضلع التبريد
45 handlebar (handlebars)	مَقْوَد	20 cooling ribs	مِسْنَد الدَّرَاجَة النارية
46 chain guard	وقاء الجِزْزِير/السلسلة	21 motorcycle stand	جِزْزِير الدَّرَاجَة النارية
47 motor scooter (scooter)	دَّرَاجَة "سكوتر" بمخَرَك لُوْح جانبيّ قابل للفصل	22 motorcycle chain	ممتصّ صدمات تليسكوبي
48 removable side panel	إطار أنبوبي	23 telescopic shock absorber	شعاع العجلة
49 tubular frame	أسطح إنسيابية	24 spokes	حافة العجلة
50 metal fairings	مِسْنَد الدَّرَاجَة	25 rim (wheel rim)	إطار الدَّرَاجَة النارية
51 prop stand (stand)	فرملة تعمل بالقدم	26 motorcycle tyre (<i>Am.</i> tire)	مُداس الإطار
52 foot brake	بوق	27 tyre (<i>Am.</i> tire) tread	ذراع تغيير السرعات
53 horn (hooter)	خُطاف لتطويق حقيبة يد أو حقيبة خفيفة	28 gear-change lever (gear	

shift lever	مقبض التحكم في صمام الاختناق
29 twist grip throttle control (throttle twist grip)	مقبض التحكم في صمام الاختناق
30 rear-view mirror (mirror)	مرآة الرؤية الخلفية
31-58 heavy (heavy-weight, large-capacity) motorcycles	دراجات نارية ثقيلة (كبيرة السعة)
31 heavyweight motorcycle with water-cooled engine	دراجة نارية ثقيلة ذات محرك تبريد ماء
32 front disc (disk) brake	فرملة قرصية أمامية
33 disc (disk) brake calliper (caliper)	الآلية الفكية للفرملة القرصية
34 floating axle	محور طاف
35 water cooler	مُبرّد ماء
36 fuel tank (petrol tank, Am. gasoline tank)	خزان الوقود
37 indicator (indicator light, turn indicator light)	ضوء إرشادي للانعطاف
38 kickstarter	آلية بدء التشغيل بالقدم
39 water-cooled engine	مُحرك تبريد ماء
40 speedometer	عداد السرعة
41 rev counter (revolution counter)	عداد الدورات
42 rear indicator (indicator light)	مصباح إرشادي خلفي
43 heavy (heavyweight, high-performance) machine with fairing [1000 cc]	ماكينة ثقيلة إنسيابية السطح [1000 سي سي]
44 integrated streamlining, an integrated fairing	سطح إنسيابي متكامل
45 indicator (indicator light, turn indicator light)	ضوء إرشادي للانعطاف
46 anti-mist windscreen (Am. windshield)	حاجب ريع مقاوم للضباب
47 horizontally-opposed twin engine with cardan transmission	مُحرك مزدوج متقابل أفقياً ذو ناقل حركة كارداني
48 light alloy wheel	عجلة من سبيكة خفيفة الوزن
49 four-cylinder machine [400 cc]	ماكينة ذات أربع أسطوانات [400 سي سي]
50 air-cooled four-cylinder four-stroke engine	مُحرك تبريد هواء رباعي الأسواط ذو أربع أسطوانات
51 four-pipe megaphone exhaust pipe	ماسورة عادم بوقية ذات أربعة أنابيب
52 electric starter button	زر بادئ التشغيل كهربائياً
53 sidecar machine	ماكينة بغربة جانبية
54 sidecar body	جسم الغربة الجانبية
55 sidecar crash bar	صناد الغربة الجانبية (وقاء الاصطدام)
56 sidelight (Am. side-marker lamp)	مصباح إشارة جانبي

57 sidecar wheel	عجلة الغربة الجانبية
58 sidecar windscreen (Am. windshield)	حاجب ريع الغربة الجانبية
190 Internal Combustion Engines	مُحركات الاحتراق الداخلي
1 eight-cylinder V (vee) fuel-injection spark-ignition engine (Otto-cycle engine)	مُحرك ذو 8 أسطوانات مُرتبة على شكل V يعمل بنظام حقن الوقود وإشعال الشرر (مُحرك دورة أوتو)
2 cross-section of spark-ignition engine (Otto-cycle internal combustion engine)	مقطع عرضي لمُحرك يعمل بإشعال الشرر (مُحرك الاحتراق الداخلي بدوّرة أوتو)
3 sectional view of five-cylinder in-line diesel engine	منظر مقطعي لمُحرك ديزل مستقيم ذو خمس أسطوانات
4 cross-section of diesel engine	مقطع عرضي لمُحرك الديزل
5 two-rotor Wankel engine (rotary engine)	مُحرك "فانكل" (مُحرك دوار) ذو عضونين دوارين
6 single-cylinder two-stroke internal combustion engine	مُحرك احتراق داخلي ثنائي الأسواط ذو أسطوانة واحدة
7 fan	مروحة
8 fan clutch for viscous drive	قابض المروحة للدفع اللزج
9 ignition distributor (distributor) with vacuum timing control	موزع إشعال بالآلية للتحكم في توقيت الإشعال بالخلطة
10 double roller chain	سلسلة بدحارج مزدوجة
11 camshaft bearing	محمل عمود الكامات
12 air-bleed duct	منزف الهواء
13 oil pipe for camshaft lubrication	انبوب زيت لتزليق عمود الكامات
14 camshaft, an overhead camshaft	عمود الكامات
15 venturi throat	حلق "فنتوري"
16 intake silencer (absorption silencer, Am. absorption muffler)	شكمان السحب
17 fuel pressure regulator	منظم ضغط الوقود
18 inlet manifold	مجمع السحب
19 cylinder crankcase	كارتير الأسطوانة
20 flywheel	الحذافة
21 connecting rod (piston rod)	ذراع توصيل (قضيب الكياس)
22 cover of crankshaft bearing	غطاء محمل العمود المرفقي
23 crankshaft	العمود المرفقي
24 oil bleeder screw (oil drain plug)	سدادة تصريف الزيت
25 roller chain of oil pump drive	سلسلة بدحارج لوحة إدارة مضخة الزيت
26 vibration damper	مضائل الاهتزازات
27 distributor shaft for the ignition distributor (distributor)	عمود موزع الإشعال
28 oil filler neck	عنق فتحة ملء الزيت

29 diaphragm spring	ياي رفي
30 control linkage	أضال الحُكم
31 fuel supply pipe (Am. fuel line)	أنبوب إمداد الوقود (خط الوقود)
32 fuel injector (injection nozzle)	حاقن الوقود
33 rocker arm	ذراع تَرْجِيحة
34 rocker arm mounting	محمل الذراع التَرْجِيحية
35 spark plug (sparking plug) with suppressor	شمعة شرر (بوجيه) ذات مانع للشرر
36 exhaust manifold	مجمع العادم
37 piston with piston rings and oil scraper ring	كباس ذو حلقات وحلقة كسح الزيت
38 engine mounting	ركوبية المُحرك
39 dog flange (dog)	شفة كلابية
40 crankcase	علبة المَرافق، كارتير
41 oil sump (sump)	الخوض السفلي للزيت
42 oil pump	مضخة الزيت
43 oil filter	مُرشح الزيت
44 starter motor (starting motor)	موتور بادئ التشغيل
45 cylinder head	رأس الأسطوانة
46 exhaust valve	صمام العادم
47 dipstick	قضيب قياس منسوب الزيت
48 cylinder head cover	غطاء (جوزان) رأس الأسطوانات
49 double bushing chain	سلسلة ذات حلبة مزدوجة
50 warm-up regulator	منظم التسخين
51 tapered needle for idling adjustment	إبرة مُستدقة لضبط التباطؤ
52 fuel pressure pipe (fuel pressure line)	أنبوب ضغط الوقود
53 fuel leak line (drip fuel line)	خط تقطيط الوقود
54 injection nozzle (spray nozzle)	فوهة الحقن
55 heater plug	شمعة مروحة التدفئة
56 thrust washer	حلقة دفعية
57 intermediate gear shaft for the injection pump drive	عمود الترس المتوسط الخاص بإدارة مضخة الحقن
58 injection timer unit	وحدة توقيت الحقن
59 vacuum pump (low-pressure regulator)	مضخة خلخلة (منظم الضغط المنخفض)
60 cam for vacuum pump	كامة مضخة الخلخلة
61 water pump (coolant pump)	مضخة الماء (مضخة المبرّد)
62 cooling water thermostat	ترموستات ماء التبريد
63 thermo time switch	مفتاح توقيت حراري
64 fuel hand pump	مضخة يدوية للوقود
65 injection pump	مضخة الحقن
66 glow plug	شمعة توهج
67 oil pressure limiting valve	صمام تحديد ضغط الزيت
68 rotor	العضو الدوّار (في محرك "فانكل")
69 seal	برشام
70 torque converter	محول العزم

71 single-plate clutch	قابض مُفرّد القرص
72 multi-speed gearing (multi-step gearing)	صندوق تروس متعدد السرعات
73 port liners in the exhaust manifold for emission control	بطانات المنفذ في مجمع العادم للتحكم في الانبعاثات
74 disc (disk) brake	فرملة قرصية
75 differential gear (differential)	ترس فرقي (دفرانسيه)
76 generator	مولّد كهربائي
77 foot gear-change control (foot gearshift control)	أداة التحكم السفلية في نقل التروس
78 dry multi-plate clutch	قابض جاف متعدد الأقراص
79 cross-draught (Am. cross-draft) carburettor (Am. carburetor)	مكربن (كاربورايتور) سحب مُضاد
80 cooling ribs	ضلع التبريد
81 V-belt (fan belt)	سُرّ على شكل حرف V (سُرّ المروحة)
191 Motor Car (Am. automobile) I	المسيّارة (I)
1-56 motor car (car, Am. automobile, auto), passenger vehicle	المسيّارة (مركبة آلية)
1 monocoque body (unitary body)	بدن قشري
2 chassis, the under-structure of the body	هيكل السيّارة (الشاسيه)
3 front wing (Am. front fender)	صناد أمامي، رُفرف أمامي
4 car door	باب السيّارة
5 door handle	مقبض الباب
6 door lock	قفل الباب
7 boot lid (trunk lid)	غطاء صندوق السيّارة
8 bonnet (Am. hood)	غطاء مُحرك السيّارة
9 radiator	المشع
10 cooling water pipe	أنبوب ماء التبريد
11 radiator grill	شبكة وقاية المشع
12 badging	علامة ماركة السيّارة
13 rubber-covered front bumper (Am. front fender)	صناد أمامي مغطى بالنمطاط
14 car wheel, a disc (disk) wheel	دولاب سيّارة
15 car tyre (Am. automobile tire)	إطار الدولاب (الجزء المطاطي من الدولاب)
16 rim (wheel rim)	الحذافة (حافة الإطار)
17-18 disc (disk) brake	فرملة قرصية
17 brake disc (disk) (braking disc)	قرص الفرملة
18 calliper (caliper)	آلية فكية
19 front indicator light (front turn indicator light)	لمبة إشارة أمامية (لمبة إشارة انعطاف أمامية)
20 headlight (headlamp) with main beam (high	المصباح الأمامي ذو قلاب للإضاءة القريبة والبعيدة

beam), dipped beam (low beam), sidelight (side lamp, <i>Am.</i> side-marker lamp)	ولمبة جانبية	53 engine mounting	مثبت المحرك
21 windscreen (<i>Am.</i> windshield), a panoramic windscreen	الرُّجَاج الأمامي، حاجب الريح	54 intake silencer (<i>Am.</i> intake muffler)	كاتم صوت السحب
22 crank-operated car window	رُجَاج يَمَّ تحريكه بذراع دوراني	55 air filter (air cleaner)	مرشِّح الهواء
23 quarter light (quarter vent)	هَوَايَة جانبية	56 right-hand wing mirror	مرآة الجانب الأيمن
24 boot (<i>Am.</i> trunk)	صندوق السيارة	57-90 dashboard (fascia panel)	لوحة التابلوه
25 spare wheel	دوَلاب احتياطي	57 controlled-collapse steering column	عمود قيادة اضياعي محكوم
26 damper (shock absorber)	مُخدِّد الاهتزازات	58 steering wheel spoke	ضلع عجلة القيادة
27 trailing arm	ذراع تعليق خلفي	59 indicator and dimming switch	مفتاح المنيب والعاتم
28 coil spring	نايض مُكثف	60 wiper/washer switch and horn	مفتاح تشغيل المساحات/ الرشاش والبوق
29 silencer (<i>Am.</i> muffler)	شكمان، كاتم الصوت	61 side window blower	نافع هواء الرُّجَاج الجانبي
30 automatic ventilation system	نظام تهوية آلي	62 sidelight, headlight, and parking light switch	مفتاح تشغيل المصابيح الجانبية والأمامية ولمبة الانتظار
31 rear seats	المقعد الخلفي	63 fog lamp warning light	ضوء التحذير الخاص بمصباح الضباب
32 rear window	الرُّجَاج الخلفي	64 fog headlamp and rear lamp switch	مفتاح الضوء الأمامي والخلفي الخاص بالمصباح
33 adjustable headrest (head restraint)	ميسد رأس قابل للضبط	65 fuel gauge (<i>Am.</i> gage)	عداد الوقود
34 driver's seat, a reclining seat	مقعد السائق	66 water temperature gauge (<i>Am.</i> gage)	عداد حرارة الماء
35 reclining backrest	مسند ظهر قابل للسط	67 warning light for rear fog lamp	ضوء التحذير الخاص بمصباح الضباب الخلفي
36 passenger seat	مقعد الركاب الأمامي	68 hazard flasher switch	مفتاح المفازات في حالة الخطر
37 steering wheel	عجلة القيادة	69 main beam warning light	ضوء التحذير الخاص بالكشاف الرئيسي
38 centre (<i>Am.</i> center) console containing speedometer (<i>coll.</i> speedo), revolution counter (rev counter, tachometer), clock, fuel gauge (<i>Am.</i> gage), water temperature gauge, oil temperature gauge	كوسول مركزي يشتمل على عداد السرعة وعداد سرعة الدوران وساعة ومؤشر الوقود وعداد حرارة الماء وعداد حرارة الزيت.	70 electric rev counter (revolution counter)	عداد سرعة الدوران (عداد الغالات)
39 inside rear-view mirror	مرآة الرؤية الخلفية الداخلية	71 fuel warning light	الضوء التحذيري لنقص الوقود
40 left-hand wing mirror	مرآة الجانب الأيسر	72 warning light for the hand brake and dual-circuit brake system	الضوء التحذيري الخاص بنظام فرملة اليد والفرامل مزدوجة الدائرة
41 windscreen wiper (<i>Am.</i> windshield wiper)	مساحة الرُّجَاج الأمامي	73 oil pressure warning light	الضوء التحذيري لضغط الزيت
42 defroster vents	فتحات ترميل الصمغ (الدافقية)	74 speedometer (<i>coll.</i> speedo) with trip mileage recorder	عداد السرعة وبه عداد الكيلومترات (الأميال)
43 carpeting	فرش أرضية السيارة	75 starter and steering lock	فعل بدء التشغيل والمُوجِّه
44 clutch pedal (<i>coll.</i> clutch)	دواسة القابض	76 warning lights for turn indicators and hazard flashers	الأضواء التحذيرية الخاصة بمصابيح الانعطافات وغمغمات الخطر
45 brake pedal (<i>coll.</i> brake)	دواسة الفرملة	77 switch for the courtesy light and reset button for the trip mileage recorder	زر الإضاءة الداخلية وضبط عداد الكيلومترات (الأميال)
46 accelerator pedal (<i>coll.</i> accelerator)	دواسة المُعجِّل، دواسة الوقود	78 ammeter	أميتر
47 inlet vent	فتحة السحب	79 electric clock	ساعة كهربية
48 blower fan	مروحة نافخة	80 warning light for heated rear window	ضوء تحذيري خاص بالرُّجَاج الخلفي المسخن
49 brake fluid reservoir	خزان سائل الفرامل	81 switch for the leg space ventilation	مفتاح تهوية حيز الأرجل
50 battery	بطارية	82 rear window heating	مفتاح تسخين الرُّجَاج
51 exhaust pipe	ماسورة العادم		
52 front running gear with front wheel drive	تروس أمامي دوار مع إدارة العجلات الأمامية		

53 ventilation switch	الخلفي	23 crankshaft bearing (main bearing)	محمل العمود المرفقي
83 temperature regulator	مفتاح التهوئة	24 camshaft bearing	محمل عمود الكامات
85 fresh-air inlet and control	منظم ذرجة الحرارة	25 connecting-rod bearing	محمل قضيب التَّوَصيل
86 fresh-air regulator	مدخل الهواء الطلق والتحكم فيه اتجاهه وكثيته	26 gudgeon pin (piston pin)	بِنْد الكَباس
87 warm-air regulator	منظم الهواء الساخن	27 bleed	مترِّف
88 cigar lighter	قَدَاحَة السجائر	28-47 four-speed synchromesh gearbox	صندوق تروس مترانم التسعيق رباعي السرعات
89 glove compartment (glove box) lock	قفل حَبيْرة التابلوه	28 clutch pedal	دواسة القابض
90 car radio	راديو السيارة	29 crankshaft	عمود مرفقي
91 gear lever (gearshift lever), a floor-type gear-change	ذراع تبديل السرعة (الفتيس)، فتيس أرضي	30 drive shaft (propeller shaft)	عمود الدفع
92 leather gaiter	وقاء من الجلد	31 starting gear ring	حلقة تروس بدء الحركة
93 hand brake lever	ذراع الفرملة اليدوية	32 sliding sleeve for 3rd and 4th gear	كَم مَرِّزَلق لتعشيق السرعتين الثالثة والرابعة
94 accelerator pedal	دواسة الوقود/ المُعجِّل	33 synchronizing cone	مُترِّب تزامني
95 brake pedal	دواسة الفرملة	34 helical gear wheel for 3rd gear	عجلة تروس لولبي لتعشيق السرعة الثالثة
96 clutch pedal	دواسة القابض	35 sliding sleeve for 1st and 2nd gear	كَم مَرِّزَلق لتعشيق السرعتين الأولى والثانية
97 seat belt (safety belt)	حزام المقعد (حزام الأمان)	36 helical gear wheel for 1st gear	عجلة تروس لولبي لتعشيق السرعة الأولى
		37 lay shaft	عمود وسيط
		38 speedometer drive	إدارة عداد السرعة
		39 helical gear wheel for speedometer drive	عجلة تروس لولبي لإدارة عداد السرعة
		40 main shaft	العمود الرئيسي
		41 gearshift rods	قضبان نقل التروس
		42 selector fork for 1st and 2nd gear	شوكة انتقاء تعشيق السرعتين الأولى والثانية
		43 helical gear wheel for 2nd gear	عجلة تروس لولبي لتعشيق السرعة الثانية
		44 selector head with reverse gear	رأس الانتقاء مع تروس السرعة الخلفية
		45 selector fork for 3rd and 4th gear	شوكة انتقاء السرعتين الثالثة والرابعة
		46 gear lever (gearshift lever)	ذراع نقل السرعات (ذراع الفتيس)
		47 gear-change pattern (gearshift pattern, shift pattern)	نمط تغيير السرعات
		48-55 disc (disk) brake [assembly]	فرملة قرصية [مجموعة]
		48 brake disc (disk) (braking disc)	قرص الفرملة
		49 calliper (caliper), a fixed calliper with friction pads	آلية فكِّية (آلية فكِّية ثابتة ذات لقم احتكاك)
		50 servo cylinder (servo unit)	وحدة موازنة (سرفو)
		51 brake shoes	حذاء الفرملة
		52 brake lining	بطانة الفرملة
		53 outlet to brake line	فتحة تؤدي إلى خط زيت الفرملة
		54 wheel cylinder	أسطوانة الدوَلاب
		55 return spring	نايض إرجاع
		56-59 steering gear	آلية القيادة (التوجيه)
192 Motor Car (<i>Am.</i> Automobile) II	السيارة (2)		
1-15 carburettor (<i>Am.</i> carburetor), a down-draft (<i>Am.</i> down-draft) carburettor	المكربن (الريدياتور)		
1 idling jet (slow-running jet)	منفذ التناطو، فوهة السرعة البطيئة		
2 idling air jet (idle air bleed)	منفذ الهواء البطيء		
3 air correction jet	منفذ تصحيح الهواء		
4 compensating airstream	تيار هواء لتعادل		
5 main airstream	تيار هواء رئيسي		
6 choke flap	قلاب الخائق		
7 plunger	غاطس، كباس		
8 venturi	أنبوب فينتوري		
9 throttle valve (butterfly valve)	صمام خائق		
10 emulsion tube	أنبوب المستحلب		
11 idle mixture adjustment screw	برغي ضبط خليط السرعة البطيئة		
12 main jet	المنفذ الرئيسي		
13 fuel inlet (<i>Am.</i> gasoline inlet) (inlet manifold)	ماسورة الإمداد بالوقود		
14 float chamber	غرفة العوامة		
15 float	عوامة		
16-27 pressure-feed lubricating system	نظام التزيت بالضغط		
16 oil pump	مضخة الزيت		
17 oil sump	خوض الزيت		
18 sump filter	مرشِّح خوض الزيت		
19 oil cooler	مُبرِّد الزيت		
20 oil filter	مرشِّح الزيت		
21 main oil gallery (drilled gallery)	ممر الزيت الرئيسي		
22 crankshaft drilling (crankshaft tributary, crankshaft bleed)	مترِّف العمود الرئيسي		

(worm-and-nut steering gear)	7 rear seat (back seat)	المقعد الخلفي
56 steering column	8 fastback saloon (<i>Am.</i> fastback sedan)	سيارة صالون ذات مؤخرة ممتورة
57 worm gear sector	9 tailgate	باب المؤخرة
58 steering drop arm	10 fastback (stubback)	مؤخرة تساعد على زيادة السرعة (مؤخرة ممتورة)
59 worm	11 cross-country vehicle with all-wheel drive (four-wheel drive)	سيارة أسفار نظام دفع بالأربع عجلات
60-64 water-controlled heater	12 spare wheel	دوَلاب احتياطي
60 air intake	13 roll bar	قضيب أسطواني للتثبيت
61 heat exchanger (heater box)	14 cabriolet sports coupé (cabriolet sports car)	سيارة كابرولييه، سيارة مكشوفة
62 blower fan	15 integral seat	مقعد ثابت
63 flap valve	16 automatic hood (<i>Am.</i> top) (power-operated hood, <i>Am.</i> top)	سقف يتحرك آلياً
64 defroster vent	17 estate car (estate, shooting brake, <i>Am.</i> station wagon)	سيارة ستيشن
65-71 live axle (rigid axle)	18 boot space (luggage compartment)	صندوق الأمتعة
65 propeller shaft	19 small three-door car	سيارة صغيرة بثلاثة أبواب
66 trailing arm	20 back (tailgate)	المؤخرة (باب المؤخرة)
67 rubber bush	21 sill	عتبة
68 coil spring	22 folding back seat	مقعد خلفي قابل للطي
69 damper (shock absorber)	23 boot (luggage compartment, <i>Am.</i> trunk)	صندوق السيارة
70 Panhard rod	24 (sliding) sunroof (steel sliding sunroof)	سقف منزلق
71 stabilizer bar	25 three-door hatchback	سيارة بثلاثة أبواب ممتورة المؤخرة
72-84 MacPherson strut unit	26 roadster (sports cabrio, sports cabriolet), a two-seater	سيارة خفيفة مكشوفة (سيارة ذات مقعدين)
72 body-fixing plate	27 hard top	سقف ثابت صلب
73 upper bearing	28 sports coupé, a two-plus-two (two-seater with occasional seats)	سيارة كوبيه بياطين
74 suspension spring	29 fastback	مؤخرة تساعد على زيادة السرعة
75 piston rod	30 occasional seat	مقعد معد للاستخدام عند الحاجة
76 suspension damper	31 low-profile tyre (<i>Am.</i> tire) (wide wheel)	إطار مقلص الجانبية (دوَلاب عريض)
77 rim (wheel rim)	32 gran turismo car (GT car)	سيارة جوتي
78 stub axle	33 integral bumper (<i>Am.</i> integral fender)	مصعد غير قابل للفصل
79 steering arm	34 rear spoiler	مقصد خلفي
80 track-rod ball-joint	35 back	مقصد أمامي
81 trailing link arm	36 front spoiler	
82 bump rubber (rubber bonding)		
83 lower bearing		
84 lower suspension arm		
	194 Lorries (<i>Am.</i> Trucks), Vans, Buses	الشاحنات وعربات النقل الخفيفة والحافلات
193 Motor Car (<i>Am.</i> Automobile) III	1 light cross-country	شاحنة خفيفة نظام دفع
1-36 car models (<i>Am.</i> automobile models)		
1 four-door touring saloon (<i>Am.</i> four-door sedan) in the upper-middle range		
2 driver's door		
3 rear door		
4-10 four-door saloon (<i>Am.</i> four-door sedan) and four-door hatchback in the middle range		
4 saloon (<i>Am.</i> sedan)		
5 headrests (head restraints)		
6 front seat		

lorry (light truck, pick-up truck) with all-wheel drive (four-wheel drive)	بالأربع عجلات	37 lower deck (lower saloon)	الطابق السفلي
2 cab (driver's cab)	كابينة السائق	38 upper deck (upper saloon)	الطابق العلوي
3 loading platform (body)	صندوق التّحميل	39 boarding platform	منصة صعود الحافلة
4 spare tyre (<i>Am.</i> spare tire), a cross-country tyre	دوَلاب احتياطي	40 trolley bus	الترولي باص
5 light lorry (light truck, pick-up truck)	شاحنة خفيفة	41 current collector	ذراع توصيل التيار
6 platform truck	شاحنة بصندوق	42 trolley (trolley shoe)	حذاء الترولي
7 medium van	عربة نقل متوسطة الحجم	43 overhead wires	سلك علوي
8 sliding side door [for loading and unloading]	باب جانبي منزلق [للتحميل والتفريغ]	44 trolley bus trailer	مقطورة الترولي باص
9 minibus	حافلة صغيرة (ميني باص)	45 pneumatically sprung rubber connection	وصلة مطاطية بنابض هوائي
10 folding top (sliding roof)	سقف قابل للطي		
11 rear door	باب خلفي	195 Garage (<i>Am.</i> Shop)	المكراج (الجراج)
12 hinged side door	باب جانبي مثبت بمفصل	1-55 agent's garage (distributor's garage, <i>Am.</i> specialty shop)	كراج الوكيل (كراج موزع السيارات)
13 luggage compartment	خزانة الأمتعة	1-23 diagnostic test bay	خزانة الفحص
14 passenger seat	مقعد الركاب	1 computer	حاسيب آلي (كمبيوتر)
15 cab (driver's cab)	كابينة السائق	2 main computer socket	قابس الحاسب الآلي الرئيسي
16 air inlet	فتحة دخول الهواء	3 computer harness (computer cable)	كبل الحاسب الآلي
17 motor coach (coach, bus)	حافلة بمحرك	4 switch from automatic to manual	مفتاح التحويل من التشغيل الآلي إلى اليدوي
18 luggage locker	خزانة الأمتعة	5 slot for program cards	فتحة إدخال بطاقات البرامج
19 hand luggage (suitcase, case)	حقائب يد (حقائب ملابس)	6 printout machine (printer)	طابعة
20 heavy lorry (heavy truck, heavy motor truck)	شاحنة ثقيلة	7 condition report (data printout)	تقرير فحص السيارة
21 tractive unit (tractor, towing vehicle)	وحدة الجر/القطر (الجرار)	8 master selector (hand control)	ذراع التحكم الرئيسية
22 trailer (drawbar trailer)	مقطورة	9 light read-out [green: OK; red: not OK]	شاشة ضوئية [أخضر سليم، أحمر غير سليم]
23 swop platform (body)	صندوق المقطورة	10 rack for program cards	رف بطاقات البرامج
24 three-way tipper (three-way dump truck)	عربة ثلاثية	11 mains button	المفتاح الرئيسية
25 tipping body (dump body)	صندوق قلب	12 switch for fast readout	مفتاح القراءة السريعة
26 hydraulic cylinder	أسطوانة هيدروليكية	13 firing sequence insert	وليفة تعاقب الإشعال
27 supported container platform	حاجية مرفوعة على دعائم	14 shelf for used cards	رف البطاقات المستعملة
28 articulated vehicle, a vehicle tanker	مركبة مفصلة	15 cable boom	دعامة الكيبلات
29 tractive unit (tractor, towing vehicle)	وحدة الجر (الجرار)	16 oil temperature sensor	جهاز إحصاس حرارة الزيت
30-33 semi-trailer (skeletal)	نصف مقطورة	17 test equipment for wheel and steering alignment	معدات فحص الترخيص (ضبط الإسقاطة)
30 tank	خزان	18 right-hand optic plate	لوحة بصرية يميني
31 turntable	سطح دوّار	19 actuating transistors	ترانزستورات التشغيل
32 undercarriage	عربة سفلية	20 projector switch	مفتاح البروجكتور
33 spare wheel	دوَلاب احتياطي	21 check light for wheel alignment, a row of photocells	ضوء فحص الترخيص، صف من الخلايا الضوئية
34 midi bus [for short-route town operations]	حافلة متوسطة للمسافات القصيرة داخل المدينة [أبواب تفتح باتجاه الخارج]	22 check light for steering alignment, a row of photocells	ضوء فحص إسقاطة التوجيه (صف من الخلايا الضوئية)
35 outward-opening doors	أبواب تفتح باتجاه الخارج	23 power screwdriver	مفك كهربائي
36 double-deck bus (double-decker bus)	حافلة ذات طبقتين	24 beam setter	منظم ذراع الميزان
		25 hydraulic lift	مرفأع هيدرولي

26 adjustable arm of hydraulic lift	ذراع المرفاع الهيدرولي القابلة للتعديل	regular petrol (Am. gasoline) (sim. for derv)	بنزين عادي
27 hydraulic lift pad	بطانة المرفاع الهيدرولي	2 hose (petrol pump, Am. gasoline pump, hose)	خراطيم المضخة
28 excavation	خفرة، بئر	3 nozzle	بزاز، فوهة
29 pressure gauge (Am. gage)	مقياس الضغط	4 cash readout	بيان القيمة النقدية المطلوبة
30 grease gun	مُسَدَس شحيم	5 volume readout	بيان عداد التيارات المستحوطة
31 storage box for small parts	صندوق حفظ الأجزاء الصغيرة	6 price display	بيان السعر
32 wall chart [of spare parts]	لوحة حائطية (توضّح قطع الغيار)	7 indicator light	ضوء إشاري
33 automatic computer test	فحص آلي بالكمبيوتر	8 driver using self-service petrol pump (Am. gasoline pump)	سائق يستخدم مضخة بنزين محطة الخدمة الذاتية
34 motor car (car, Am. automobile, auto), a passenger vehicle	سيارة	9 fire extinguisher	مطفأة الحريق
35 engine compartment	حجرة المحرك	10 paper-towel dispenser	جهاز المناشف الورقية
36 bonnet (Am. hood)	غطاء المحرك	11 paper towel	منشفة ورقية
37 bonnet support (Am. hood support)	مِسَد غطاء المحرك	12 litter receptacle	صندوق المهملات
38 computer harness (computer cable)	كبل الكمبيوتر	13 two-stroke blending pump	مضخة بنزين ثنائية الأشواط
39 main computer socket	مقبس الكمبيوتر الرئيسي	14 meter	عداد
40 oil temperature sensor	جهاز إحساس حرارة الزيت	15 engine oil	زيت المحركات
41 wheel mirror for visual wheel and steering alignment	مرآة الدوالب لفحص استقامة الدوالب والتوجيه بصرياً	16 oil can	علبة زيت
42 tool trolley	تrolley الأدوات	17 tyre pressure gauge (Am. tire pressure gage)	مقياس ضغط الإطارات
43 tools	أدوات	18 air hose	خراطيم الهواء
44 impact wrench	مفتاح ربط صدمي	19 static air tank	خزان هواء استاتي
45 torque wrench	مفتاح ربط يقيس عزم اللي	20 pressure gauge (Am. gage) (manometer)	مقياس ضغط (مانومتر)
46 body hammer (roughing-out hammer)	مطرقة سكرّة	21 air filler neck	عنق جهاز تعبئة الهواء
47 vehicle under repair, a minibus	عربة تحت الإصلاح، ميني باص	22 repair bay (repair shop)	ورشة الإصلاح
48 car location number	رقم موقع السيارة	23 car-wash hose, a hose (hosepipe)	خراطيم غسل السيارات
49 rear engine	محرك خلفي	24 accessory shop	محلّ بيع الكماليات
50 tailgate	باب المؤخرة	25 petrol can (Am. gasoline can)	صفيحة بنزين
51 exhaust system	نظام العادم	26 rain cape	غطاء واق من المطر
52 exhaust repair	إصلاح نظام العادم	27 car tyres (Am. auto-mobile tires)	إطارات السيارات
53 motor car mechanic (motor vehicle mechanic, Am. auto-motive mechanic)	ميكانيكي سيارات	28 car accessories	كماليات السيارات
54 air hose	خراطيم الهواء	29 cash desk (console)	خزينة دفع النقدية
55 intercom	جهاز اتصال داخلي (انتركوم)		
196 Service Station	محطة خدمة السيارات	197 Tram (Am. Streetcar, Trolley), Interurban Electric Train	الترام، قطار كهربائي للخدمة بين الضواحي
1-29 service station (petrol station, filling station, Am. gasoline station, gas station), a self-service station	محطة خدمة السيارات (محطة البنزين)، محطة الخدمة الذاتية	1 twelve-axle articulated railcar for interurban rail service	عربة سلك حديدية مفصّلة ذات 12 محوراً للخدمة بين الضواحي
1 petrol (Am. gasoline) pump (blending pump) for unleaded (lead-free) premium grade and	مضخة البنزين الممتاز الخالي من الرصاص والبنزين العادي	2 current collector	قضيب توصيل التيار الكهربائي
		3 head of the railcar	مقدمة العربة
		4 rear of the railcar	مؤخرة العربة
		5 carriage A containing the motor	العربة (أ) وتحمل المحرك
		6 carriage B (also carriages C and D)	العربة (ب)، أيضاً العربات (ج) و(د)
		7 carriage E containing the motor	العربة (هـ) وتحمل المحرك

8 rear controller	المراقب الخلفي	contact wire)	سلك علوي متقاطع
9 driving bogie	بوجي الإدارة، مجمع عجلات الإدارة	42 overhead cross wire	آلية التقاط الكهربائية (أيضاً الكهروهيدرولية والكهروميكانيكية)
10 carrying bogie	بوجي حمل	43 electric (also: electro-hydraulic, electro-mechanical) points mechanism	مقطع عرضي للشوارع
11 wheel guard	وقاء العجلة	198 Cross-section of a Street	طبقات الطريق
12 bumper (Am. fender)	مصد	1-5 road layers	طبقة مقاومة للصقيع
13 six-axle articulated rail-car ("Mannheim" type) for tram (Am. streetcar, trolley) and urban rail services	عربة سلك حديدية مفصّلة ذات ستة محاور للخدمة الترام والخدمة في المدينة	1 anti-frost layer	طبقة تحتانية من البتومين
14 entrance and exit door, a double folding door	باب الركوب والذبول	2 bituminous sub-base course	طبقة قاعدية
15 step	القابل للخطى	3 base course	طبقة من مادة لاصقة
16 ticket-cancelling machine	ذرجة	4 binder course	سطح بيتوميني
17 single seat	معدّ مقعد	5 bituminous surface	حافة الرصيف
18 standing room portion	الجزء المخصّص للوقوف	6 kerb (curb)	حجر الحافة
19 double scat	معدّ مزدوج	7 kerbstone (curbstone)	رصف
20 route (number) and destination sign	لافتة خط السير واتجاه الرحلة	8 paving (pavement)	الرصيف
21 route sign (number sign)	لافتة رقم العربة	9 pavement (Am. sidewalk, walkway)	بالوعة تصريف
22 indicator (indicator light)	ضوء إرشادي	10 gutter	غور المشاة
23 pantograph (current collector)	باننوجراف (ذراع توصيل التيار)	11 pedestrian crossing (zebra crossing, Am. crosswalk)	منخفض الشارع
24 carbon or aluminium (Am. aluminium) alloy trolley shoes	حذاء ترولي مصنوع من سبيكة الكربون أو الألومنيوم	12 street corner	الشارع
25 driver's position	موقع السائق	13 street	كيبلات الكهرباء
26 microphone	ميكروفون	14 electricity cables	كيبلات الهاتف
27 controller	مفتاح تحكم	15 telephone cables	أنبوب كيبلات الهاتف
28 radio equipment (radio communication set)	جهاز الراديو	16 telephone cable pipeline	فتحة بئر كيبلات ذات غطاء
29 dashboard	لوحة التابلوه	17 cable manhole with cover (with manhole cover)	عمود النور وبه مصباح
30 dashboard lighting	لمعات لوحة التابلوه	18 lamp post with lamp	كيبلات كهرباء للتوصيلات الفنية
31 speedometer	عداد السرعة	19 electricity cables for technical installations	خطوط هواتف المشتركين
32 buttons controlling doors, windscreen wipers, internal and external lighting	أزرار التحكم في الأبواب والمشاعح والإضاءة الداخلية والخارجية	20 subscribers' (Am. customers') telephone lines	ماسورة الغاز الرئيسية
33 ticket counter with change machine	عداد التذاكر وماكينه صرف	21 gas main	ماسورة الماء الرئيسية
34 radio antenna	هوائي الراديو	22 water main	بالوعة
35 tram stop (Am. streetcar stop, trolley stop)	محطة الترام	23 drain	غطاء البالوعة
36 tram stop sign (Am. streetcar stop sign, trolley stop sign)	لافتة محطة الترام	24 drain cover	ماسورة تصريف ماء المطر
37 electric change points	نقاط تحويل المسار الكهربائي	25 drain pipe	ماسورة تصريف المجاري
38 points signal (switch signal)	إشارة نقاط التحويل (إشارة التحويل)	26 waste pipe	مجزور مشدّد
39 points change indicator	تحويل المسار	27 combined sewer	مأخذ تدفئة المنطقة الرئيسي
40 trolley wire contact point	نقطة تلامس سلك الترولي	28 district heating main	نفق مترو الأنفاق
41 trolley wire (overhead)	سلك الترولي	29 underground tunnel	
		199 Refuse Disposal (Am. Garbage Disposition), Street Cleaning	التخلص من النفايات، تنظيف الشوارع
		1 refuse collection vehicle (Am. garbage truck)	عربة جمع النفايات
		2 dustbin-tipping device (Am. garbage can dumping device), a	جهاز قلب صندوق النفايات

dust-free emptying system	مَقْشَة أسطوانية
3 dustbin (<i>Am. garbage can, trash can</i>)	مَشْدُوق النِّفَايَات
4 refuse container (<i>Am. garbage container</i>)	حَاوِيَة النِّفَايَات
5 road sweeper (<i>Am. street sweeper</i>)	كَنَّاس الشَّارِع
6 broom	مَكْسَّة، مَقْشَة
7 fluorescent armband	شُرَيْط ذِرَاع فلورسنتي
8 cap with fluorescent band	قَبْعَة بِشُرَيْط فلورسنتي
9 road sweeper's (<i>Am. street sweeper's</i>) barrow	عَرَبَة كَنَّاس الشَّارِع
10 controlled tip (<i>Am. sanitary landfill, sanitary fill</i>)	مَنْطِقَة رَدَم النِّفَايَات
11 screen	حَاجِز
12 weigh office	مَكْتَب الوَزْن
13 fence	سِيَّاح
14 embankment	سَد
15 access ramp	طَرِيق مَتَحَدِر
16 bulldozer	بُلْدُوَزِر
17 refuse (<i>Am. garbage</i>)	نِّفَايَات
18 bulldozer for dumping and compacting	بُلْدُوَزِر لِالرَّمِّ وَالدَّمَج
19 pump shaft	بُتْر العِصْحَة
20 waste water pump	مِصْحَة المَاء المَهْدُور
21 porous cover	غِطَاء مَسَامِي
22 compacted and decomposed refuse	نِّفَايَات مَدْمَجَة وَمُتَكَلِّفَة
23 gravel filter layer	طَبَقَة تَرْشِيع الحِصِي
24 morainic filter layer	طَبَقَة تَرْشِيع رَكَامِيَة
25 drainage layer	طَبَقَة الصَّرْف الصَّحِي
26 drain pipe	مَاسُورَة الصَّرْف
27 water tank	خَزَان مَاء
28 refuse (<i>Am. garbage</i>) incineration unit	وَحْدَة إِحْرَاق النِّفَايَات
29 furnace	فَرْن
30 oil-firing system	نِظَام إِشْعَال بَالزَيْت
31 separation plant	وَحْدَة الفِرَاز
32 extraction fan	مَرْوَحَة طَرْد
33 low-pressure fan for the grate	مَرْوَحَة ضِعْط مُنْحَفِض
34 continuous feed grate	الشَّبَكَة المِصْبِغَة
35 fan for the oil-firing system	شَبَكَة مُصِيبَة لِالتغذِيَة المِستمرَة
36 conveyor for separately incinerated material	مَرْوَحَة نِظَام الإِشْعَال بِالزَيْت
37 coal feed conveyor	نَاقِل المَوَاد المَحْرُوقَة عَلى حِدَة
38 truck for carrying fuller's earth	نَاقِل الإِقَام الفَحْم شَاحِجَة نَقْل تَرَاب فُوللر
39 mechanical sweeper	عَرَبَة كَنَّاس آليَة
40 circular broom	مَكْسَة دَوَّارَة
41 road-sweeping lorry (<i>street-cleaning lorry, street cleaner</i>)	شَاحِجَة كَنَّاس الشُّوَارِع

42 cylinder broom	مَقْشَة أسطوانية
43 suction port	فَتْحَة الشفط
44 feeder broom	مَقْشَة تغذِيَة فتحة الشفط
45 air flow	مَرْدَق الهواء
46 fan	مَرْوَحَة
47 dust collector	حَاوِيَة تَجْمِيع التُّرَاب

200 Road Construction I (Road Building, Road Making)

1-54 road-building machinery	مَآكِنَات بِنَاء/تَعْبِيد الطَّرِيق
1 shovel (power shovel, excavator)	حَفَّار
2 machine housing	مَبْنِيَة المَآكِنَة
3 caterpillar mounting (<i>Am. caterpillar tractor</i>)	جِرَارَة مَرْنَجَرَة
4 digging bucket arm (dipper stick)	ذِرَاع حَفَر دَلْوِيَة
5 digging bucket (bucket)	قَادُوس الحَفَر
6 digging bucket (bucket) teeth	أَسْنَان قَادُوس الحَفَر
7 tipper (dump truck), a heavy lorry (<i>Am. truck</i>)	شَاحِجَة قَلْبَة
8 tipping body (<i>Am. dump body</i>)	صندوق القَلَاب
9 reinforcing rib	ضَلْع تَقْوِيَة
10 extended front	مَقْدَمَة مَبْتَدَة
11 cab (driver's cab)	كَابِيْنَة السَّائِق
12 bulk material	مَوَاد سَائِجَة
13 concrete scraper, an aggregate scraper	خَلَّاط الخِرسَانَة
14 skip hoist	مِرْفَاع قَادُوسِي
15 mixing drum (mixer drum), a mixing machine	بِرْمِيل الخِلَاط
16 caterpillar hauling scraper	مَكْسُطَة جِرَارَة مَرْنَجَرَة
17 scraper blade	سِلَاح المَكْسُطَة
18 levelling (<i>Am. leveling</i>) blade (smoothing blade)	سِلَاح التَّسْوِيَة
19 grader (motor grader)	مُهَيِّدَة الطَّرِيق (جَرِيدِر)
20 scarifier (ripper, road ripper, rooter)	مِخْدَشَة (لِيْبشِ سَطْح الطَّرِيق قَبْل إِعَادَة التَّعْبِيد)
21 grader levelling (<i>Am. leveling</i>) blade (grader ploughshare, <i>Am. plowshare</i>)	أَسْطَوَانَة التَّسْوِيَة بِالمِخْدَشَة
22 blade-slewing gear (slew turntable)	تُرْس الإِلْتِفَاف الخَاص بِسِلَاح المِخْدَشَة
23 light railway (narrow-gauge, <i>Am. narrow-gauge, railway</i>)	عَرَبَة سَكَّة حَدِيدِيَة خَفِيْفَة (سَكَّة حَدِيدِيَة صِغِيْرَة)
24 light railway (narrow-gauge, <i>Am. narrow-gauge</i>) diesel	قَاطِرَة دِيزِل حَدِيدِيَة خَفِيْفَة

locomotive	عَرَبَة الجِرَار
25 trailer wagon (wagon truck, skip)	مِدْقَة
26 tamper (rammer); heavier: frog	قَضِيَان دَلِيلِيَة
27 guide rods	بُلْدُوَزِر
28 bulldozer	سَكِينَة البُلْدُوَزِر
29 bulldozer blade	إِطَار دَفْع
30 pushing frame	مَآكِنَة تَعْبِيد/رِصْف الطَّرِيق
31 road-metal spreading machine (macadam spreader, stone spreader)	قَضِيْب دَاك
32 tamping beam	لُوحَة سَلِيْبَة
33 sole-plate	مِصْد جَانِبِي
34 side stop	جَانِب صندُوق التَّخْزِين
35 side of storage bin	هَرَّاس ذُو ثَلَاث عَجَلَات
36 three-wheeled roller, a road roller	هَرَّاس
37 roller	سَقْف لِكَاْفَة الأَجْوَاء
38 all-weather roof	ضَآئِغ هَوَاء مُنْتَقَل يَعْمَل بِالدَّيزِل
39 mobile diesel-powered air compressor	أَسْطَوَانَة الأَكْسِجِين
40 oxygen cylinder	مَآكِنَة فَرَش حِصِي ذَاتِيَة الحَرَكَة
41 self-propelled gritter	قَلْبَة فَرَش الحِصِي
42 spreading flap	مَآكِنَة إِجْرَاز السَطْح
43 surface finisher	مِصْد جَانِبِي صندُوق
44 side stop	مَآكِنَة فَرَش القَطْرَان مَع سَخَّان القَطْرَان وَالبِتومِين
45 bin	خَزَان القَطْرَان
46 tar-spraying machine (bituminous distributor) with tar and bitumen heater	وَحْدَة خَلْط وَتَجْيِيف الأَسْفَلْت أليَا
47 tar storage tank	مِرْفَاع قَادُوسِي
48 fully automatic asphalt drying and mixing plant	بِرْمِيل خَلْط الأَسْفَلْت
49 bucket elevator (elevating conveyor)	مِرْفَاع المَادَة لِلاصْفَة
50 asphalt-mixing drum (asphalt mixer drum)	فَتْحَة المَادَة لِلاصْفَة
51 filler hoist	فَتْحَة خُرُوج الأَسْفَلْت المَخْلُوط
52 filler opening	مَقَطْع عَرَضِي نِطْطِي لِطَرِيق
53 binder injector	بِتومِينِي
54 mixed asphalt outlet	حَافَة الطَّرِيق
55 typical cross-section of a bituminous road	مَنْحَدِر مِستَعْرَض
56 grass verge	السَطْح الأَسْفَلْتِي (طَبَقَة بِتومِينِيَة)
57 crossfall	قَاعِيَة (طَبَقَة قَاعِيَة)
58 asphalt surface (bituminous layer, bituminous coating)	طَبَقَة حِثْيَة صَلْدَة أَوْ طَبَقَة تَحْيِيَة مِّن الحِصِي، طَبَقَة صَآمِدَة لِالصِّغِيْر
59 base (base course)	
60 hardcore sub-base course (Telford base) or gravel sub-base course, an anti-frost	

layer	صَّرْف صَحِي حِثْيَة
61 sub-drainage	مَاسُورَة أَسْمَنْتِيَة مَتَبِعَة
62 perforated cement pipe	خَفْرَة الصَّرْف الصَّحِي
63 drainage ditch	غِطَاء التُّرْبَة
64 soil covering	

201 Road Construction II (Road Building, Road Making)

1-24 concrete road construction (highway construction)	إِثْبَاء/بِنَاء الطَّرِيق الخِرسَانِيَة (بِنَاء الطَّرِيق السَّرِيْعَة)
1 subgrade grader	مَدْرَجَة/مُهَيِّدَة الأَرْضِيَة الطَبِيعِيَة
2 tamping beam (consolidating beam)	قَضِيْب الدَّك/الدَّمَك
3 levelling (<i>Am. leveling</i>) beam	قَضِيْب التَّسْوِيَة
4 roller guides for the levelling (<i>Am. leveling</i>) beam	دَلَالِيْل أسْطَوَانِيَة لِلقَضِيْب التَّسْوِيَة
5 concrete spreader	فَارِشَة الخِرسَانَة
6 concrete spreader box	صندُوق فَارِشَة الخِرسَانَة
7 cable guides	دَلَالِيْل كَبِيلِيَة
8 control levers	أَذْرَاع التَّكْمِك
9 handwheel for emptying the boxes	عَجَلَة يدوِيَة لِتَفْرِغ الصِّنَادِيق
10 concrete-vibrating compactor	آلَة دَمَك هَرَّازَة لِالخِرسَانَة المِصْبُوبَة
11 gearing (gears)	مِجْمُوعَة السَّنَنَات
12 control levers (operating levers)	أَذْرَاع التَّكْمِك (أَذْرَاع التَّشْغِيل)
13 axle drive shaft to vibrators (tamper) of vibrating beam	عَمُود إِدَارَة مَحْوَرِي مُوَصَّل لِهَرَّازَات قَضِيْب هَرَّاز الخِرسَانَة
14 screeding board (screeding beam)	لُوح دَلِيلِي لِالخِطَانَة، لُوح تَّسْوِيَة
15 road form	قَالِب رِصْف الطَّرِيق
16 joint cutter	قَاطِع الخِرسَانَة
17 joint-cutting blade	سِلَاح قَطْع الخِرسَانَة
18 crank for propelling machine	ذِرَاع تَدْوِير مَآكِنَة الدَّفْع
19 concrete-mixing plant, a stationary central mixing plant, an automatic batching and mixing plant	وَحْدَة خَلْط الخِرسَانَة، وَحْدَة مَرْكَزِيَة ثَابِتَة لِخَلْط الخِرسَانَة، وَحْدَة آليَة لِتَحْدِيد النَّمْعَات وَالخَلْط
20 collecting bin	خَوْص تَجْمِيع
21 bucket elevator	مِصْدَع القَادُوس
22 cement store	خَزَان الأَسْمَنْت
23 concrete mixer	خَلَّاط الخِرسَانَة
24 concrete pump hopper	قَادُوس مِصْحَة الخِرسَانَة

202 Railway Line (<i>Am. Railroad Track</i>) I	خَط السَكَّة الحَدِيدِيَة (1)
1-38 line (track)	خَط السَكَّة الحَدِيدِيَة
1 rail	قَضِيْب السَكَّة الحَدِيدِيَة

2 rail head	رأس القضيب	37 concrete sleeper (<i>Am.</i> concrete tie, concrete crossie)	فلنكة من الخرسانة	9 colour light (<i>Am.</i> color light) distant signal at 'be prepared to stop at next signal'	إشارة مسافة ضوئية ملونة عند "استعد للتوقف عند الإشارة القادمة"	from distant signal	250 متراً من إشارة المسافة
3 web (rail web)	وكرة القضيب	38 coupled sleeper (<i>Am.</i> coupled tie, coupled crossie)	فلنكة مزدوجة	10 signal position: 'be prepared to proceed at low speed'	وَضِعْ إشارة "استعد للتقدم بسرعة منخفضة"	29 approach sign at a distance of 5% less than the braking distance on the section	علامة الاقتراب بمسافة 5% أقل من مسافة الفرملة على قطاع القضيب
4 rail foot (rail bottom)	قاعدة القضيب	39-50 level crossings (<i>Am.</i> grade crossings)	التقاطعات المستوية، المرزقات	11 signal position: 'proceed main signal ahead'	وَضِعْ إشارة "تقدم للإشارة الرئيسية في الأمام"	30 chequered sign indicating stop signals (main signals) not positioned immediately to the right of or over the line (track)	علامة مربعات تشير إلى أن إشارات التوقف غير موضوعة على يمين أو فوق الخط مباشرة
5 sole-plate (base plate)	لوحة القاعدة	39 protected level crossing (<i>Am.</i> protected grade crossing)	مرزقان محمي الشكل	12 semaphore plate with indicator plate showing a reduction in braking distance of more than 5%	إشارة سيمافور ذات لوحة توضيحية تشير إلى مسافة فرملة مقللة تزيد عن 5%	31, 32 stop boards to indicate the stopping point of the front of the train	لوحات تَوَقَّفْ تشير إلى نقطة إيقاف مقدمة القطار
6 cushion	وسادة (لتلطيف الصدمة)	40 barrier (gate)	حاجز (بوابة)	13 triangle (triangle sign)	مثلث، لافتة مثلثة	33 stop board indicating 'be prepared to stop'	لوحة تَوَقَّفْ "استعد للوقوف"
7 coach screw (coach bolt)	برغي ذو رأس مربع	41 warning cross (<i>Am.</i> crossbuck)	إشارة التحذير	14 colour light (<i>Am.</i> color light) distant signal with indicator light for showing reduced braking distance	إشارة مسافة ضوئية ملونة ذات ضوء إرشادي يوضِّع مسافة فرملة مقللة	34-35 snow plough (<i>Am.</i> snowplow) signs	علامتا جرافات الثلوج
8 lock washers (spring washers)	حوامل زنق	42 crossing keeper (<i>Am.</i> gateman)	عامل مراقبة المرزقان	15 supplementary white light	ضوء أبيض إضافي	34 'raise snow plough (<i>Am.</i> snowplow) signs	علامة "ارفع جرافة الثلوج"
9 rail clip (clip)	مشبك القضيب	43 crossing keeper's box (<i>Am.</i> gateman's box)	كثك عامل مراقبة المرزقان	16 distant signal indicating 'be prepared to stop at next signal' (yellow light)	إشارة مسافة تشير إلى "استعد للتوقف عند الإشارة القادمة" (ضوء أصفر)	35 'lower snow plough (<i>Am.</i> snowplow) sign	علامة "أخفض جرافة الثلوج"
10 T-head bolt	مسمار ربط له رأس ثنائي الشكل	44 linesman (<i>Am.</i> track-walker)	عامل السكة الحديدية	17 second distant signal (distant signal with supplementary light, without indicator plate)	إشارة مسافة ثانية مزودة بضوء إضافي ولا يوجد بها لوحة إرشادية	36-44 speed restriction signs	علامات الحد من السرعة
11 rail joint (joint)	وصلة قضيب السكة الحديدية	45 half-barrier crossing	مرزقان للعبور في اتجاهين	18 distant signal with speed indicator	إشارة مسافة بها لوحة توضيح السرعة	36-38 speed restriction sign [maximum speed 3 x 10 = 30 kph]	علامة الحد من السرعة [أقصى سرعة = 10 × 3 = 30 كم/س]
12 fishplate	لوح وصل تراكبي للقضبان	46 warning light	ضوء تحذيري	19 distant speed indicator	مبين سرعة المسافة	37 sign for day running	علامة التشغيل نهاراً
13 fishbolt	مسمار الوصلات التراكبية	47 intercom-controlled crossing; <i>sim.</i> : telephone-controlled crossing	مرزقان يتم التحكم فيه هاتفياً	20 distant signal with route indicator	إشارة مسافة بها لوحة مبين الطريق	38 speed code number	رقم كود السرعة
14 coupled sleeper (<i>Am.</i> coupled tie, coupled crossie)	فلنكان/رافقتان مقترنتان	48 intercom system	نظام التحكم هاتفياً	21 route indicator	لوحة مبين المسار	38 illuminated sign for night running	علامة ضوئية للتشغيل ليلاً
15 coupling bolt	مسمار ربط	49 unprotected level crossing (<i>Am.</i> unprotected grade crossing)	مرزقان مفتوح	22 distant signal without supplementary arm in position: 'be prepared to stop at next signal'	إشارة مسافة بدون ذراع إضافي في وضع "استعد للتوقف عند الإشارة القادمة"	39 commencement of temporary speed restriction	بداية الحد من السرعة مؤقتاً
16 manually-operated points (manually-operated switch)	مسمار تحويل تُشغَل يدوياً	50 warning light	ضوء تحذيري	23 distant signal without supplementary arm in 'be prepared to proceed' position	إشارة مسافة بدون ذراع إضافي في وضع "استعد للتقدم"	40 termination of temporary speed restriction	انتهاء الحد من السرعة المؤقتة
17 switch stand	قاعدة المبحوال، مؤقف التحويل	203 Railway Line (<i>Am.</i> Railroad Track) II (Signalling Equipment)	خط السكة الحديدية (2) (معدات الإشارة)	24 distant signal identification plate	لوحة تعريف إشارة المسافة	41 speed restriction sign for a section with a permanent speed restriction [maximum speed 5 x 10 = 50 kph]	علامة الحد من السرعة لمقطع له سرعة محددة بصفة دائمة [أقصى سرعة = 10 × 5 = 50 كم/س]
18 weight	ثقل	1-6 stop signals (main signals)	إشارات التوقف (الإشارات الرئيسية)	25-44 supplementary signals	إشارات إضافية في وضع "استعد للتوقف عند الإشارة القادمة"	42 commencement of permanent speed restriction	بداية الحد من السرعة بصفة دائمة
19 points signal (switch signal, points signal lamp, switch signal lamp)	إشارة المبحوال	1 stop signal (main signal), a semaphore signal in 'stop' position	إشارة التوقف (إشارة رئيسية)، إشارة السيمافور في موقع "توقف"	26 approach sign 100 m from distant signal	علامة الاقتراب بمسافة 100 متر من إشارة المسافة	43 speed restriction warning sign [only on main lines]	علامة التنبيه إلى الحد من السرعة (على الخطوط الرئيسية فقط)
20 pull rod	قضيب جذب (قضيب مفتاح التحويل)	2 signal arm (semaphore arm)	ذراع الإشارة (ذراع السيمافور)	27 approach sign 175 m from distant signal	علامة الاقتراب بمسافة 175 متراً من إشارة المسافة	44 speed restriction sign [only on main lines]	علامة الحد من السرعة (على الخطوط الرئيسية فقط)
21 switch blade (switch tongue)	قضيب جذب (قضيب مفتاح التحويل)	3 electric stop signal (colour light, <i>Am.</i> color light, signal) at 'stop'	إشارة توقف كهربائية عند نقطة "توقف" (مضباج ملون)	28 approach sign 250 m from distant signal	علامة الاقتراب بمسافة 250 متر من إشارة المسافة	45-52 point signals (switch signals)	إشارات التحويلات
22 slide chair	كرسي منزلق	4 signal position: 'proceed at low speed'	وَضِعْ إشارة "تقدم بسرعة منخفضة"			45-48 single points (single switches)	تحويلات فردية
23 check rail (guard rail)	قضيب واق	5 signal position: 'proceed'	وَضِعْ إشارة "تقدم"			45 route straight ahead (main line)	الطريق مستقيم أمامك (خط رئيسي)
24 frog	مقص، مفرق أو تقاطع السكة الحديدية	6 substitute signal	إشارة بديلة			46 [right] branch	تفرع [يمين]
25 wing rail	قضيب التخرز (القضبان الجانبية الخارجة لمفرق أو تقاطع)	7-24 distant signals	إشارات المسافات			47 [left] branch	تفرع [يسار]
26 closure rail	قضيب إغلاق	7 semaphore signal at 'be prepared to stop at next signal'	إشارة سيمافور عند "استعد للتوقف عند الإشارة القادمة"				
27 remote-controlled points (remote-controlled switch)	خطوط تحويل يتم تشغيلها ألياً عن بعد	8 supplementary semaphore arm	ذراع سيمافور إضافي				
28 point lock (switch lock)	قفل التحويل						
29 stretcher bar	قضيب شداد (لمفتاح السكة الحديدية)						
30 point wire	سلك المبحوال						
31 turnbuckle	شدادة						
32 channel	قناة						
33 electrically illuminated points signal (switch signal)	إشارة مبحوال تضاء بالكهرباء						
34 trough	مجرى						
35 points motor with protective casing	موتور خطوط التحويل داخل صندوق للحماية						
36 steel sleeper (<i>Am.</i> steel tie, steel crossie)	فلنكة من الصلب						

48 branch [seen from the frog]	تَفَرُّع [كما تراه من المقص]
49-52 double crossover	خط تحويلية مزدوج
49 route straight ahead from left to right	الطريق مستقيم أمامك من اليسار إلى اليمين
50 route straight ahead from right to left	الطريق مستقيم أمامك من اليمين إلى اليسار
51 turnout to the left from the left	تحويلية جهة اليسار عند اليسار
52 turnout to the right from the right	تحويلية جهة اليمين من اليمين
53 manually-operated signal box (Am. signal tower, switch tower)	كُنْثَك تشغيل الإشارات يدوياً
54 lever mechanism	آلية أَذْرَج التشغيل
55 points lever (switch lever) [blue], a lock lever	ذِرَاع التحويلات [أزرق]
56 signal lever [red]	ذِرَاع الإشارات [أحمر]
57 catch	ذِرَاع تثبيت
58 route lever	ذِرَاع المسار
59 block instruments	آلات البلوكات
60 block section panel	لَوْحَة مَقْطَع البلوك
61 electrically-operated signal box (Am. signal tower, switch tower)	كُنْثَك تشغيل الإشارات كهربياً
62 points (switch) and signal knobs	مَقْبَض تشغيل التحويلات والإشارات
63 lock indicator panel	لَوْحَة إرشادية للأقفال
64 track and signal indicator	شاشة إرشادية للإشارات والمسارات
65 track diagram control layout	تصميم التحكم في مخطط المسارات
66 track diagram control panel (domino panel)	لَوْحَة التحكم في مخطط المسارات
67 push buttons	أزرار انضغاطية
68 routes	المسارات
69 intercom system	نظام الاتصال الداخلي (انتركوم)
204 Station Concourse	صالة المحطة
1 parcels office	مكتب الطرود
2 parcels	طرود
3 basket [with lock]	سلة [ذات قفل]
4 luggage counter	كاونتر وِزْن الأمتعة
5 platform scale with dial	ميزان بمنصة للأمتعة ذو مقياس مدرج
6 suitcase (case)	حقية ملابس
7 luggage sticker	بطاقة لاصقة توضع على الأمتعة
8 luggage receipt	إيصـال استلام الأمتعة
9 luggage clerk	موظف استلام الأمتعة ووزنها
10 poster (advertisement)	إعلان حائطي (بوستر)
11 station post box (Am. station mailbox)	صندوق بريد المحطة
12 station guide	دليل المحطة
13 station restaurant	مطعم المحطة
14 waiting room	غرفة الانتظار

15 map of the town (street map)	خريطة المدينة
16 timetable (Am. schedule)	جدول
17 ticket machine	ماكينة التذاكر
18 arrivals and departures board (timetable)	لوحة إعلان مواعيد الوصول والمغادرة
19 arrival timetable (Am. arrival schedule)	جدول مواعيد الوصول
20 departure timetable (Am. departure schedule)	جدول مواعيد المغادرة
21 left luggage lockers	دواليب حفظ الأمانات
22 change machine	ماكينة صرافة، ماكينة استبدال العملة
23 tunnel to the platforms	نفق يؤدي إلى أرصفة القطارات
24 passengers	ركاب
25 steps to the platforms	درج يؤدي إلى أرصفة القطارات
26 station bookstand (Am. station bookstand)	كُنْثَك بيع الكتب والمجلات بالمنطقة
27 left luggage office (left luggage)	مكتب إيداع الأمتعة بالأمانات
28 travel centre (Am. center); also: accommodation bureau	مركز خدمات السفر والسياحة
29 information office (Am. information bureau)	مكتب الاستعلامات
30 station clock	ساعة المحطة
31 bank branch with foreign exchange counter	فروع أحد البنوك وبه شباك صرافة
32 indicator board showing exchange rates	لوحة إرشادية تعرض أسعار الصراف
33 railway map (Am. railroad map)	خريطة السكك الحديدية
34 ticket office	مكتب بيع وحجز التذاكر
35 ticket counter	شباك التذاكر
36 ticket	تذكرة القطار
37 revolving tray	صينية دوارة
38 grill	نفاثة
39 ticket clerk (Am. ticket agent)	موظف شباك التذاكر
40 pane of glass (window)	لوح من الزجاج (شباك)
41 pocket timetable (Am. pocket train schedule)	جدول مواعيد القطارات للجيب
42 luggage rest	مسند الأمتعة
43 first aid station	مركز الإسعافات الأولية
44 Travellers' Aid	مكتب مساعدة المسافرين
45 railway (Am. railroad) information clerk	موظف استعلامات السكة الحديد
46 official timetable (official railway guide, Am. train schedule)	جدول مواعيد القطارات
205 Station Platform	رصيف المحطة
1 platform	رصيف القطارات
2 steps to the platform	درج يؤدي إلى الرصيف

3 bridge	جسر يؤدي إلى الرصيف
4 platform number	رقم الرصيف
5 platform roofing	سقف الرصيف
6 passengers	ركاب
7-12 luggage	أمتعة
7 suitcase (case)	حقية ملابس
8 luggage label	بطاقة تُلصَق على الأمتعة
9 hotel sticker	بطاقة لاصقة تشير إلى الفندق
10 travelling (Am. traveling) bag	حقية سفر
11 hat box	علبة القبعة
12 umbrella, a walking-stick umbrella	مظلة، شمسية
13 offices	مكاتب
14 platform	الرصيف
15 crossing	مَعْبُر ركوب القطار
16 news trolley	ترولي بيع الجرائد
17 news vendor (Am. news dealer)	بائع الجرائد
18 reading matter for the journey	مطبوعات للقراءة أثناء السفر
19 edge of the platform	حافة الرصيف
20 railway policeman (Am. railroad policeman)	رجل شرطة السكك الحديدية
21 destination board	لوحة بيان وجهة القطار
22 destination indicator	بيان وجهة القطار
23 departure time indicator	بيان وقت المغادرة
24 delay indicator	بيان التأخير عن الموعد المحدد
25 suburban train, a railcar	قطار مخصص للنقل بين الضواحي
26 special compartment	خجيرة خاصة
27 platform loudspeaker	مكبر صوت بالرصيف
28 station sign	علامة المحطة
29 electric trolley (electric truck)	ترولي كهربائي
30 loading foreman	ملاحظ الشياطين
31 porter (Am. redcap)	شياطين
32 barrow	عربة يدوية
33 drinking fountain	حنفية مياه للشرب
34 electric Eurocity express; also: IC express (Intercity express)	قطار كهربائي سريع للنقل بين مدن أوروبا
35 electric locomotive, an express locomotive	قاطرة كهربائية، قاطرة سريعة (قاطرة اكسبريس)
36 collector bow (sliding bow)	آلية توصيل التيار الكهربائي
37 secretarial compartment	خجيرة السكرتارية
38 destination board	لوحة بيان وجهة القطار
39 wheel tapper	عامل نقر العجلة
40 wheel-tapping hammer	مطرقة نقر العجلة
41 station foreman	ملاحظ المحطة
42 signal	لافتة، إشارة
43 red cap	كاب أحمر
44 inspector	مفتش القطار

45 pocket timetable (Am. pocket train schedule)	جدول جيب بمواعيد القطارات
46 platform clock	ساعة الرصيف
47 starting signal	إشارة بدء تحريك القطار
48 platform lighting	مصابيح إنارة الرصيف
49 refreshment kiosk	كُنْثَك بيع المرطبات
50 beer bottle	زجاجة جعة، زجاجة بيوة
51 newspaper	جريدة، صحيفة
52 parting kiss	قبلة توديع
53 embrace	عناق
54 platform seat	مقعد الرصيف
55 litter bin (Am. trash bin)	صندوق المهملات
56 platform post box (Am. platform mailbox)	صندوق بريد الرصيف
57 platform telephone	تليفون الرصيف
58 trolley wire (overhead contact wire)	سلك التروولي، سلك التلامس العلوي
59-61 track	مسار السكك الحديدية
59 rail	قضيب
60 sleeper (Am. tie, crosstie)	فئكة، راقدة
61 ballast (bed)	فرشة حصى
206 Goods Station (Freight Depot)	محطة البضائع (مستودع الشحن)
1 ramp (vehicle ramp); sim.: livestock ramp	طريق منحدر لل عربات
2 electric truck	عربة كهربائية
3 trailer	مقطورة
4 part loads (Am. package freight, less-than-carload freight); in general traffic: general goods in general consignments (in mixed consignments)	شحنة مغلقة، في العام بضائع عامة في شحنات عامة
5 crate	قفص/صندوق شحن
6 goods van (Am. freight car)	عربة الشحن (عربة البضائع)
7 goods shed (Am. freight house)	غبار الشحن
8 loading strip	منطقة التحميل
9 loading dock	رصيف التحميل
10 bale of peat	بالة من قماش الخث
11 bale of linen (of linen cloth)	بالة من الكتان
12 fastening (cord)	رباط، حبل
13 wicker bottle (wickered bottle, demijohn)	قنينة مغلدة
14 trolley	ترولي
15 goods lorry (Am. freight truck)	عربة نقل البضائع
16 forklift truck (fork truck, forklift)	مرمق شوكي
17 loading siding	خط التحميل
18 bulky goods	بضائع ضخمة
19 small railway-owned (Am. railroad-owned)	حايوية صغيرة مملوكة للسكك الحديدية

20 container	سفن	53 warehouse	مستودع
20 showman's caravan (sim.: Circus caravan)	كرفان تابع للسيّرك	54 container station	مركز الحاويات
21 flat wagon (Am. flat freight car)	عربة شحن مسطحة	55 gantry crane	مرفأ قطريّ متحرك
22 loading gauge (Am. gage)	مقياس التحميل	56 lifting gear (hoisting gear)	معدّة الرفع
23 bale of straw	بالة قشّ	57 container	حاوية
24 flat wagon (Am. flat-car) with side stakes	عربة مسطحة مزودة بأوتاد جانبية	58 container wagon (Am. container car)	عربة نقل الحاويات
25 fleet of lorries (Am. trucks)	أسطول من عربات النقل	59 semi-trailer	نصف مقطورة
26-39 goods shed (Am. freight house)	عنبر البضائع	207 Railway Vehicles (Rolling Stock) I	عربات السكك الحديدية (I)
26 goods office (forwarding office, Am. freight office)	مكتب شحن البضائع	1-21 express train coach (express train carriage, express train car, corridor compartment coach), a passenger coach	عربة ركاب القطار السريع
27 part-load goods (Am. package freight)	شحنات مغلقة	1 side elevation (side view)	مسقط جانبي
28 forwarding agent (Am. freight agent, shipper)	وكيل الشحن	2 coach bod	جسم العربة
29 loading foreman	ملاحظ الشحن	3 underframe (frame)	الهيكّل السفليّ، الحاملة
30 consignment note (waybill)	بوليصة الشحن	4 bogie (truck) with steel and rubber suspension and shock absorbers	مجمع عجلات ذو تعليق صلب ومطاط ومخمدات الصدمات
31 weighing machine	ماكينة الوزن	5 battery containers (battery boxes)	صناديق البطاريات
32 pallet	منصّة نقالة	6 steam and electric heat exchanger for the heating system	مبادل الحرارة والبخار الخاص بنظام التدفئة
33 porter	شّيال	7 sliding window	نافذة منزّلة
34 electric cart (electric truck)	عربة نقل كهربائية	8 rubber connecting seal	وصلة مطاطية محكمة
35 trailer	مقطورة	9 ventilator	آلية تهوية
36 loading supervisor	مشرف الشحن	10-21 plan	تصميم العربة
37 goods shed door (Am. freight house door)	باب عنبر البضائع/عنبر الشحن	10 second-class section	قسم الدرجة الثانية
38 rail (slide rail)	قضيب (قضيب انزلاقي)	11 corridor	ممرّ العربة
39 roller	عجلة أسطوانية	12 folding seat (tip-up seat)	مقعد قابل للطي
40 weighbridge office	مكتب جسر قبّان	13 passenger compartment (compartment)	مقصورة المسافرين
41 weighbridge	جسر قبّان	14 compartment door	باب المقصورة
42 marshalling yard (Am. classification yard, switch yard)	ساحة التحويل	15 washroom	خّبيزة الغسيل
43 shunting engine (shunting locomotive, shunter, Am. switch engine, switcher)	قاطرة التحويل	16 toilet (lavatory, WC)	دورة مياه
44 marshalling yard signal box (Am. classification yard switch tower)	كشك إشارات ساحة التحويل	17 first-class section	قسم الدرجة الأولى
45 yardmaster	مسئول الساحة	18 swing door	باب أرجوحي
46 hump	خديّة، سنّام	19 sliding connecting door	باب توصيل منزلق
47 sorting siding (classification siding, classification track)	خطّ الفرز والتصنيف	20 door	باب
48 rail brake (retarder)	قضيب فرملة	21 vestibule	دهليز، رواق
49 slipper brake (slipper)	فرملة انزلاقية	22-32 dining car (restaurant car, diner)	عربة المطعم
50 storage siding (siding)	خطّ تخزين	22-25 side elevation (side view)	مسقط جانبي
51 buffer (buffers, Am. bumper)	مصدّ	22 door	باب
52 wagon load (Am. carload)	حمولة عربة	23 loading door	باب تحميل
		24 current collector for supplying power during stops	قضيب توصيل التيار الكهربائي لإمداد الطاقة أثناء التوقيفات
		25 battery boxes (battery containers)	صناديق البطاريات

26-32 plan	تصميم عربة المطعم	cover	مسد دراع مرود بمفصصة
26 staff washroom	غرفة غسل خاصة بالعاملين	69 armrest with ashtray	سجانر
27 storage cupboard	صنّان تخزين	70 cloakroom	خّبيزة تطبيق العباءات والمعاطف
28 washing-up area	منطقة غسل الأواني والأطباق	71 luggage compartment	خّبيزة الأمتعة
29 kitchen	المطبخ	72 toilet (lavatory, WC)	دورة مياه
30 electric oven with eight hotplates	موقد طهي كهربائي ثماني الشّعلات	73 buffet car (quick-service buffet car), a self-service restaurant car	عربة البوفيه (المطعم)
31 counter	كاؤنتر الخدمة	74 side elevation (side view)	مسقط جانبي
32 dining compartment	مطعم القطار	75 current collector for supplying power during stops	قضيب توصيل التيار الكهربائي للإمداد بالطاقة أثناء التوقف
33 dining car kitchen	مطبخ عربة المطعم	76 plan	تصميم عربة البوفيه
34 chef (head cook)	رئيس الطهاة	77 dining compartment	المطعم (خبيزة الطعام)
35 kitchen cabinet	خزانة المطبخ	78-79 buffet (buffet compartment)	البوفيه
36 sleeping car (sleepers)	عربة النوم	78 customer area	منطقة الزبائن
37 side elevation (side view)	مسقط جانبي	79 serving area	منطقة الخدمة
38-42 plan	تصميم عربة النوم	80 kitchen	المطبخ
38 two-seat twin-berth compartment (two-seat two-berth compartment, Am. bedroom)	مقصورة ذات مقعدين ومضجيتين	81 staff compartment	خّبيزة العاملين
39 folding doors	أبواب قابلة للطي	82 staff toilet (staff lavatory, staff WC)	دورة المياه للعاملين
40 washstand	حوض غسل (مغسل)	83 food compartments	خّبيزات الطعام
41 office	مكتب	84 plates	الأطباق
42 toilet (lavatory, WC)	دورة مياه	85 cutlery	أدوات المائدة (السكاكين)
43 express train compartment	مقصورة القطار السريع	86 till (cash register)	ماكينة دفع النقدية
44 upholstered reclining seat	مقعد منجد قابل للبتط	208 Railway Vehicles (Rolling Stock) II	عربات السكك الحديدية (2)
45 armrest	مسند الذراع	1-30 local train service	خدمة القطار المحلي
46 ashtray in the armrest	مفصصة سجانر ميثية بمسند الذراع	1-12 local train (short-distance train)	قطار محلي (للسافات القصيرة)
47 adjustable headrest	مسند رأسي قابل للتعديل	1 electric locomotive	قاطرة كهربية
48 antimacassar	غطاء ظهر المقعد	2 current collector	ذراع توصيل التيار
49 mirror	مرآة	3 four-axled coach (four-axled car) for short-distance routes, a passenger coach (passenger car)	عربة رباعية المحاور للسافات القصيرة، عربة ركاب
50 coat hook	علّاقة المعطف	4 bogie (truck) [with disc (disk) brakes]	مجمع عجلات [ذو فرامل قرصية]
51 luggage rack	رفّ الأمتعة	5 underframe (frame)	الهيكّل السفلي
52 compartment window	نافذة المقصورة	6 coach body with metal panelling (Am. panelling)	جسم العربة المكمسو بألواح معدنية
53 fold-away table (pull-down table)	طاولة قابلة للطي	7 double folding doors	أبواب مزدوجة قابلة للطي
54 heating regulator	منظّم التدفئة	8 compartment window	نافذة العربة
55 litter receptacle	صندوق مهلات	9 open carriage	عربة مفتوحة
56 curtain	ستارة	10 entrance	مدخل
57 footrest	مسند القدمين	11 connecting corridor	دهليز توصيل
58 corner seat	مقعد الزاوية	12 rubber connecting seal	وصلة مطاطية محكمة
59 open car	عربة مفتوحة	13 light railcar, a short-distance railcar	عربة سكة حديدية خفيفة للسافات القصيرة
60 side elevation (side view)	مسقط جانبي	14 cab (driver's cab, Am. engineer's cab)	كابينة السائق
61-72 plan	تصميم العربة المفتوحة	15 carriage door	باب العربة
61 open carriage	عربة مفتوحة		
62 row of single seats	صفّ مقاعد فردية		
63 row of double seats	صفّ مقاعد مزدوجة		
64 reclining seat	مقعد قابل للبتط		
65 seat upholstery	وسادة مقعد		
66 backrest	مسند الظهر		
67 headrest	مسند الرأس		
68 down-filled headrest cushion with nylon	وسادة مسند رأس محشوة لها غطاء من النايلون		

16 connecting hoses and coupling	خراطيم ومقارن توصيل
17 coupling link	وصلة قارئة
18 tensioning device (coupling screw with tensioning lever)	جهاز شد
19 unlinked coupling	قارئة غير موصلة
20 heating coupling hose (steam coupling hose)	خراطيم توصيل هواء التدفئة
21 coupling hose (connecting hose) for the compressed-air braking system	خراطيم قارن خاص بنظام فرملة الهواء المضغوط
22 second-class section	قسم الدرجة الثانية
23 central gangway	ممر وسط العربات
24 compartment	مقصورة
25 upholstered seat	مقعد منجد
26 armrest	مسند الذراع
27 luggage rack	رف الأمتعة
28 hat and light luggage rack	رف حفظ القبعات والأمتعة الخفيفة
29 ashtray	مبغضة السجائر
30 passenger	راكب

209 Railway Vehicles (Rolling Stock) III

1-19 Intercity Express

1 German Federal Railway trainset	قطار السكك الحديدية الألمانية
2 driving unit (power car)	وحدة الدفع (عربة الطاقة)
3 driving bogie with traction motors	مجموع عجلات ومحركات السحب
4 cab (driver's cab, Am. engineer's cab)	كابينة السائق
5 power supply (traction current filter)	إمداد الطاقة (فلتر تيار الجهد)
6 contactors (converters, inductance)	مفاتيح تلامس (محولات، محثات)
7 traction motor blower	نافع موتور السحب
8 inductance protection (converter)	وقاية المحثات (محول)
9 oil-cooling plant	وحدة تبريد الزيت
10 converter for the auxiliaries	محول المعدات المساعدة
11 electronics	أجهزة إلكترونية
12 control current equipment	معدات ضبط التيار
13 auxiliaries (switchgear)	معدات مساعدة (مجموعة المفاتيح الكهربائية)
14 pneumatic equipment	معدات تعمل بالهواء المضغوط
15 air-conditioning plant	وحدة تكييف الهواء
16 main current converters	محولات التيار الرئيسية
17 measuring equipment (diagnosis)	معدات قياس
18 continuous automatic train-running control	مضببط تشغيل القطار بشكل متواصل آلياً
19 transformer	محول

20 TGV (Train à Grande Vitesse) of the Société Nationale des Chemins de Fer Français (SNCF)	القطار السريع للجمعية القومية للسكك الحديدية الفرنسية
---	---

210 Railway Vehicles (Rolling Stock) IV

1-69 steam locomotives

2-37 locomotive boiler and driving gear

2 tender platform with coupling	عربات السكك الحديدية (4)
3 safety valve for excess boiler pressure	القاطرات البخارية
4 firebox	مرجل وقود وإدارة القاطرة
5 drop grate	مبضعة تمويين ذات مقرون صمام أمان لضغط المرجل الزائد
6 ashpan with damper doors	صندوق للهب مصنعة ساقطة
7 bottom door of the ashpan	مزمدة بها أبواب مقلبة
8 smoke tubes (flue tubes)	رمد المرجل
9 feed pump	باب السفلي للمزمدة
10 axle bearing	أنابيب الدخان
11 connecting rod	مضخة تغذية
12 steam dome	مخمل المحور
13 regulator valve (regulator main valve)	قصب توصيل
14 sand dome	قبة البخار
15 sand pipes (sand tubes)	صمام المنظم
16 boiler (boiler barrel)	قبة الرمل
17 fire tubes or steam tubes	مؤاسير الرمل
18 reversing gear (steam reversing gear)	المرجل
19 sand pipes	مؤاسير الهب أو مؤاسير البخار
20 feed valve	تروس عاكس
21 steam collector	مؤاسير الرمل
22 chimney (smokestack, smoke outlet and waste steam exhaust)	صمام تغذية
23 feedwater preheater (feedwater heater, economizer)	مدخنة (مقعد الدخان وعادم البخار)
24 spark arrester	مسخن ماء التغذية
25 blast pipe	وقاء الشرر
26 smokebox door	ماسورة العصف
27 cross head	باب صندوق الدخان
28 mud drum	طربوش
29 top feedwater tray	صندوق الحماة
30 combination lever	صينية ماء تغذية علوية
31 steam chest	رافعة تجميعية
32 cylinder	صندوق البخار
33 piston rod with stuffing box (packing box)	أسطوانة
34 guard iron (rail guard, Am. pilot, cowcatcher)	ذراع المكبس وبها صندوق الصنوبر
35 carrying axle (running	قصب أمان

axle, dead axle)	عمود مقرون
36 coupled axle	عمود الإدارة
37 driving axle	قاطرة سريعة ذات قاطرة تمويين
38 express locomotive with tender	كابينة سائق القطار
39-63 cab (driver's cab, Am. engineer's cab)	مقعد الوقاد
39 fireman's seat	ذراع المصبغة الساقطة
40 drop grate lever	حاقن البخار
41 line steam injector	مبضعة تشحيم آلي
42 automatic lubricant pump (automatic lubricator)	مقياس ضغط المسخن المتقدم
43 preheater pressure gauge (Am. gage)	مقياس ضغط تدفئة العربات
44 carriage heating pressure gauge (Am. gage)	مقياس الماء
45 water gauge (Am. gage)	مضباح الإنارة
46 light	مقياس ضغط المرجل
47 boiler pressure gauge (Am. gage)	مقياس الحرارة وقراءة المسافة
48 distant-reading temperature gauge (Am. gage)	كابينة السائق
49 cab (driver's cab, Am. engineer's cab)	مقياس ضغط الفرملة
50 brake pressure gauge (Am. gage)	مقبض صمام الصافرة
51 whistle valve handle	جدول مواعيد السائق
52 driver's timetable (Am. engineer's schedule)	صمام فرملة السائق
53 driver's brake valve (Am. engineer's brake valve)	مسجل السرعة (عدادات التوربات)
54 speed recorder (tachograph)	صمام الرمل
55 sanding valve	عجلة عاكسة
56 reversing wheel	صمام فرملة الطوارئ
57 emergency brake valve	صمام إعتاق
58 release valve	مقعد السائق
59 driver's seat (Am. engineer's seat)	وقاء نقب الإشعال
60 firehole shield	باب نقب الإشعال
61 firehole door	مرجل رأسي
62 vertical boiler	مقبض باب التوقيد
63 firedoor handle	قاطرة مفضلية
handgrip	قاطرة صهريجية
64 articulated locomotive (Garratt locomotive)	خزان الماء
65 tank locomotive	قاطرة تمويين الوقود
66 water tank	قاطرة بخارية
67 fuel tender	قاطرة ذات مقطورة ماء
68 steam storage locomotive (fireless locomotive)	وقود مكثفة
69 condensing locomotive (locomotive with	

condensing tender)	عربات السكك الحديدية (5)
211 Railway Vehicles (Rolling Stock) V	قاطرة كهربائية
1 electric locomotive	ذراع توصيل التيار
2 current collector	مفتاح التشغيل الرئيسي
3 main switch	محول عالي الضغط
4 high-tension transformer	كيبيل السف
5 roof cable	موتور جز
6 traction motor	نظام تحكم حثي في القطار
7 inductive train control system	خزان الهواء الرئيسي
8 main air reservoir	صافرة
9 whistle	تمويل تحطيطي للقاطرة
10-18 plan of locomotive	محول ذو آلية تغيير المآخذ
10 transformer with tap changer	مبرد الزيت ونافع
11 oil cooler with blower	مضخة تدوير الزيت
12 oil-circulating pump	آلية إدارة مغير المآخذ
13 tap changer driving mechanism	ضاغط هواء
14 air compressor	نافع موتور الجز
15 traction motor blower	عجلة نهائيات/مراييل
16 terminal box	مكثفات خاصة بالمحركات الإضافية
17 capacitors for auxiliary motors	غطاء المنديل
18 commutator cover	كابينة (كابينة السائق/المهندس)
19 cab (driver's cab, Am. engineer's cab)	عجلة التحكم
20 controller handwheel	ذراع ثابت
21 dead man's handle	صمام فرملة السائق
22 driver's brake valve (Am. engineer's brake valve)	صمام فرملة تابع
23 ancillary brake valve (auxiliary brake valve)	مقياس الضغط
24 pressure gauge (Am. gage)	مفتاح تحويلي للذراع الثابت
25 bypass switch for the dead man's handle	مبين قدرة الجز
26 tractive effort indicator	مبين فولطية تدفئة القطار
27 train heating voltage indicator	مبين فولطية ذو سلك تلامسي
28 contact wire voltage indicator (overhead wire voltage indicator)	مبين فولطية عالي الضغط
29 high-tension voltage indicator	مفتاح تشغيل/إيقاف ذراع توصيل التيار
30 on/off switch for the current collector	مفتاح التشغيل الرئيسي
31 main switch	مضببط مبردة الرمل
32 sander switch (sander control)	مفتاح فرامل مقاومة للانزلاق
33 anti-skid brake switch	شاشة متابعة الأنظمة التابعة
34 visual display for the ancillary systems	عداد السرعة
35 speedometer	مفتاح التشغيل المتدرج
36 running step indicator	

37 clock	ساعة	6 main air pressure gauge (<i>Am. gage</i>)	مقياس ضغط الهواء الرئيسي	41 preheater	سخان متقدم	80 hand brake wheel	عجلة الفرملة اليدوية
38 controls for the inductive train control system	مضابط نظام التحكم الحثي في القطار	7 brake cylinder pressure gauge (<i>Am. gage</i>)	مقياس ضغط أسطوانة الفرامل	42 exhaust silencer (<i>Am. exhaust muffler</i>)	كاتب الصوت، علبّة العادم	81 control wheel	عجلة التحكم
39 cab heating switch	مفتاح تدفئة الكابينة	8 main air reservoir pressure gauge (<i>Am. gage</i>)	مقياس ضغط خزان الهواء الرئيسي	43 auxiliary heat exchanger for the transmission oil	مبادل حراري ثانوي لزيت نقل السرعة	82 coupling	مقرن، كولينج
40 whistle lever	ذراع تشغيل الصافرة	9 speedometer	عداد السرعة	44 hydraulic brake	فرملة هيدروليكية	83 cardan shaft	عمود كرادان
41 contact wire maintenance vehicle (overhead wire maintenance vehicle), a diesel railcar	عربة صيانة سلك التلامس	10 auxiliary brake	فرامل إضافية	45 tool box	صندوق الأدوات	84 louvred shutter	غطاء ذو شفة للتهوية
42 work platform (working platform)	منصة الشغل	11 driver's brake valve (<i>Am. engineer's brake valve</i>)	صمام فرملة السائق	46 starter battery	بطارية بدء التشغيل	213 Railway Vehicles (Rolling Stock) VII	عربات السكك الحديدية (7)
43 ladder	سلم درجّي	12 controller handwheel	عجلة التحكم	47 diesel-hydraulic locomotive for light and medium shunting service	قاطرة ايدروليكية تعمل بالديزل لخدمة تحويلات الخط الخفيفة والمتوسطة	1 diesel-hydraulic locomotive	قاطرة ايدروليكية تعمل بالديزل
44-54 mechanical equipment of the contact wire maintenance vehicle	المعدات الميكانيكية لغربية صيانة سلك التلامس	13 dead man's handle	ذراع ثابت	48 exhaust silencer (<i>Am. exhaust muffler</i>)	كاتب الصوت، علبّة العادم	2 cab (driver's cab, <i>Am. engineer's cab</i>)	كابينة السائق/المهندس
44 air compressor	ضاغط هواء	14 inductive train control system	نظام تحكم حثي في القطار	49 bell and whistle	جرس وصافرة	3 wheel and axle set	طاقم من عجلة ومحور
45 blower oil pump	مضخة زيت النافخ	15 signal lights	لمبات الإشارة	50 yard radio	راديو اتصال بساحة القطارات	4 aerial for the yard radio	هوائي راديو ساحة القطارات
46 generator	مولد كهربائي	16 clock	ساعة	51-67 elevation of locomotive	مسقط راسي للقاطرة	5 standard flat wagon (<i>Am. standard flatcar</i>)	عربة مسطحة عادية
47 diesel engine	محرك ديزل	17 voltage meter for the train heating system	مقياس فولطية نظام تدفئة القطار	51 diesel engine with supercharged turbine	محرك ديزل يعمل بتوربين مزيد الشحن	6 hinged steel stanchion (stanchion)	قائم دعامة صلب مفضلّي
48 injection pump	مضخة حقن	18 current meter for the train heating system	مقياس تيار نظام تدفئة القطار	52 fluid transmission	نقل حركة مانعّي	7 buffers	مصنّات
49 silencer (<i>Am. muffler</i>)	كاتب الصوت، علبّة العادم	19 engine oil temperature gauge (<i>Am. gage</i>)	عداد حرارة زيت المحرك	53 output gear box	صندوق تروس الخرج	8 standard open goods wagon (<i>Am. standard open freight car</i>)	عربة بضائع عادية مفتوحة
50 change-speed gear	تروس تغيير السرعة	20 transmission oil temperature gauge (<i>Am. gage</i>)	عداد حرارة زيت عمود نقل الحركة	54 radiator	مشع	9 revolving side doors	أبواب جانبية دوّارة
51 cardan shaft	عمود كرادان	21 cooling water temperature gauge (<i>Am. gage</i>)	عداد حرارة ماء التبريد	55 heat exchanger for the engine lubricating oil	مبادل حراري لزيت تزليق المحرك	10 hinged front	مقدمة مفصّلية
52 wheel flange lubricator	مشحمة شفة العجلة	22 revolution counter (rev counter, tachometer)	عداد الفلّات	56 fuel tank	خزان الوقود	11 standard flat wagon (<i>Am. standard flatcar</i>) with bogies	عربة مسطحة عادية تسير على منجّام عجلات
53 reversing gear	ترس عاكس	23 radio telephone	تليفون لاسلكي	57 main air reservoir	خزان الهواء الرئيسي	12 sole bar reinforcement	قضيب تقوية القاعدة
54 torque converter bearing	محامل محوّل عزم الليّ	24 diesel-hydraulic locomotive [plan and elevation]	القطار ايدروليكي تعمل بالديزل [تمثيل تخطيطي ومسقط راسي]	58 air compressor	ضاغط هواء	13 bogie (truck)	منجّع عجلات
55 accumulator railcar (battery railcar)	عربة تسير بالمرحّمات	25 diesel engine	محرك يعمل بالديزل	59 sand boxes	صناديق الرمل	14 covered goods van (<i>covered goods wagon, Am. boxcar</i>)	عربة بضائع مغطّاة
56 battery box (battery container)	صندوق البطاريات	26 cooling unit	وحدة تبريد	60 reserve fuel tank	خزان الوقود الاحتياطي	15 sliding door	باب انزلاقي
57 cab (driver's cab, <i>Am. engineer's cab</i>)	كابينة السائق/المهندس	27 fluid transmission	نقل حركة مانعّي	61 auxiliary air reservoir	خزان هواء إضافي	16 ventilation flap	قلّابة تهويّة
58 second-class seating arrangement	ترتيب مقاعد الدرّجة الثانية	28 wheel and axle drive	إدارة العجلة والمحور	62 hydrostatic fan drive	إدارة مروحة هيدروليكّة	17 snow blower (rotary snow plough, <i>Am. snowplow</i>), a track-clearing vehicle	عربة إزاحة الثلوج
59 toilet (lavatory, WC)	دورة مياه	29 cardan shaft	عمود كرادان	63 seat with clothes compartment	معدّ وبه خبيرة للملابس	18 wagon (<i>Am. car</i>) with pneumatic discharge	عربة تعمل بتفريغ الهواء المضغوط
60 fast electric multiple-unit train	قطار كهربائيّ سريع متعدّد الوحدات	30 starter motor	محرك بدء التشغيل	64 hand brake wheel	عجلة الفرملة اليدوية	19 filler hole	فتحة التعبئة
61 front railcar	عربة القطار الأمامية	31 instrument panel	لوحة الآلات	65 cooling water	ماء التبريد	20 compressed-air supply	إمداد الهواء المضغوط
62 driving trailer car	عربة قاطرة الدفّع	32 driver's control desk (<i>Am. engineer's control desk</i>)	لوحة التحكم الخاصة بالسائق/المهندس	66 ballast	صانورة	21 discharge connection valve	صمام توصيل التفريغ
212 Railway Vehicles (Rolling Stock) VI	عربات السكك الحديدية (6)	33 hand brake	فرملة يدوية	67 engine and transmission control wheel	عجلة التحكم في المحرك ونقل السرعة	22 goods van (<i>Am. box-car</i>) with sliding roof	عربة بضائع ذات سقف انزلاقي
1-84 diesel locomotives	قاطرات تعمل بالديزل	34 air compressor with electric motor	ضاغط هواء ذو محرك كهربائي	68 small diesel locomotive for shunting service	قاطرة صغيرة تعمل بالديزل لخدمة تحويل الخط	23 roof opening	فتحة السقف
1 diesel-hydraulic locomotive, a mainline locomotive (diesel locomotive) for medium passenger and goods service (freight service)	قاطرة ايدروليكية تعمل بالديزل لخدمة ركاب المسافات المتوسطة والشحن	35 equipment locker	خزّانة المعدات	69 exhaust casing	غلاف علبّة العادم	24 bogie open self-discharge wagon (<i>Am. bogie open self-discharge freight car</i>)	عربة مفتوحة ذاتيّة التفريغ تتحرك على منجّام عجلات
2 bogie (truck)	منجّع عجلات	36 heat exchanger for transmission oil	مبادل حراري لزيت نقل الحركة	70 horn	بوق	25 discharge flap (discharge door)	قلّابة/باب التفريغ
3 wheel and axle set	طاقم من عجلة ومحور	37 engine room ventilator	لبّية تهوية غرفة المحرك	71 main air reservoir	خزان الهواء الرئيسي	26 bogie wagon with swivelling (<i>Am. swiveling</i>) roof	عربة ذات سقف دوّرانيّ تسير على منجّام عجلات
4 main fuel tank	خزان الوقود الرئيسي	38 magnet for the inductive train control system	مغناطيس نظام التحكم الحثي في القطار	72 air compressor	ضاغط هواء	27 swivelling (<i>Am. swiveling</i>) roof	سقف دوّرانيّ
5 cab (driver's cab, <i>Am. engineer's cab</i>) of a diesel locomotive	كابينة قاطرة الديزل	39 train heating generator	مولد كهربائي لتدفئة القطار	73 eight-cylinder diesel engine	محرك ديزل ثماني الأسطوانات		
		40 casing of the train heating system transformer	غلاف محوّل نظام تدفئة القطار	74 Voith transmission with reversing gear	نقل سرعة طراز "فويث" مع ترس عاكس		
				75 heating oil tank (fuel oil tank)	خزان زيت التدفئة		
				76 sand box	صندوق الرمل		
				77 cooling unit	وحدة التبريد		
				78 header tank for the cooling water	خزان علويّ لماء التبريد		
				79 oil bath air cleaner (oil bath air filter)	مرشّح هواء محام الزيت		

28 large-capacity wagon (Am. large-capacity car) for small livestock	عربة كبيرة الحمولة لنقل العاشية الصغيرة	(carrying wheel)	ترس الإدارة/الدفع
29 sidewall with ventilation flaps (slatted wall)	جدار جانبي ذو قلابات تهوية	8 driving pinion	جريدة ذات أسنان بالحافة العلوية]
30 ventilation flap	قلاية تهوية	9 rack [with teeth machined on top edge]	قضيب سكة حديدية
31 tank wagon (Am. tank car)	عربة صهريج	10 rail	جريدة ذات أسنان بكتا الحافتين الخارجيتين]
32 track inspection railcar	عربة سكة حديدية لفحص المسار	11 rack [with teeth on both outer edges]	سكة حديدية معلقة
33 open special wagons (Am. open special freight cars)	عربات شحن خاصة مفتوحة	12 funicular railway (funicular, cable railway)	عربة سكة حديدية معلقة كابل السحب التليفريك
34 lorry (Am. truck) with trailer	شاحنة ذات مقطورة	13 funicular railway car	سكة حديدية كبلية مفردة الكابل
35 two-tier car carrier (double-deck car carrier)	حاملة عربات ذات طابقين	14 haulage cable	مصعد السحب
36 hinged upper deck	سطح علوي مفصلي	15-24 single-cable ropeways (single-cable suspension lines), endless cableways, endless ropeways	مصعد ذو مقعد سلسلة المصعد، سلسلة مفردة مقعد مزدوج
37 tipper wagon (Am. dump car) with skips	عربة قلاية قادوسية قادوس	15 drag lift	مقعد مزدوج ذو مقرن
38 skip	قادوس	16-18 chair lift	سكة حديدية كبلية ذات عربات مكشوفة
39 general-purpose refrigerator wagon (refrigerator van, Am. refrigerator car)	برادة للأغراض العامة	16 lift chain, a single chain	عربة مكشوفة (غندولا)
40 interchangeable bodies for flat wagons (Am. flatcars)	أجسام قابلة للإبدال للعربات المسطحة	17 double lift chair, a two-seater chair	كابل تعليق مستمر
214 Mountain Railways (Am. Railroads) and Cableways	السكك الحديدية الجبلية والسكك الحديدية الكبلية	18 double chair (two-seater chair) with coupling	قضيب على شكل حرف U دعامة ذات برج مفرد حامل قنطري
1-14 mountain railways (Am. mountain railroads)	السكك الحديدية الجبلية	19 gondola cableway, an endless cableway	سكة حديدية كبلية مزدوجة الكابل
1 adhesion railcar	عربة سكة حديدية لاصقة	20 gondola (cabin)	عربة حديدية كبلية مزدوجة الكابل
2 drive	إدارة	21 endless cable, a suspension (supporting-) and haulage cable	قضيب على شكل حرف U دعامة ذات برج مفرد حامل قنطري
3 emergency brake	فرملة الطوارئ	22 U-rail	عربة حديدية كبلية مزدوجة الكابل
4 & 5 rack mountain railway (rack-and-pinion railway, cog railway, Am. cog railroad, rack railroad)	سكة حديدية ذات جريدة وترس (مسننة)	23 single-pylon support	كابل السحب
4 electric rack railway locomotive (Am. electric rack railroad locomotive)	قاطرة سكة حديدية كهربائية مسننة	24 gantry support	كابل التعليق
5 rack railway coach (rack railway trailer, Am. rack railroad car)	عربة سكة حديدية مسننة	25 double-cable ropeway (double-cable suspension line), a suspension line with balancing cabins	كابل السحب
6 tunnel	نفق	26 haulage cable	كابل التعليق
7-11 rack railways (rack-and-pinion railways, Am. rack railroads) [systems]	سكك حديدية مسننة	27 suspension cable (supporting cable)	كابل السحب
7 running wheel	عجلة التشغيل/الحمل	28 cabin	كابينة
		29 intermediate support	دعامة وسطية
		30 cableway (ropeway, suspension line), a double-cable ropeway (double-cable suspension line)	سكة حديدية كبلية
		31 pylon	برج
		32 haulage cable roller	أسطوانة كابل السحب
		33 cable guide rail (suspension cable bearing)	قضيب دليلي للكابل
		34 skip, a tipping bucket (Am. dumping bucket)	قادوس، قادوس قلب
		35 stop	ذراع إيقاف

36 pulley cradle	محمل البكرات	71 suspension cable brake (supporting cable brake), an emergency brake in case of haulage cable failure	فرملة كابل التعليق، فرملة طوارئ في حالة انقطاع كابل السحب
37 haulage cable	كابل السحب	72 suspension gear bolt	مسامير تثبيت آلية التعليق
38 suspension cable (supporting cable)	كابل التعليق	73 haulage cable sleeve	كم كابل السحب
39 valley station (lower station)	محطة ركبية (منخفضة)	74 balance cable sleeve (lower cable sleeve)	كم كابل الموازنة
40 tension weight shaft	مهواة ثقل الشد	75 derailment guard	وقاء الحيود
41 tension weight for the suspension cable (supporting cable)	ثقل شد كابل التعليق	76 cable supports (rope-way supports, suspension line supports, intermediate supports)	دعامات حمل السكة الحديدية الكبلية
42 tension weight for the haulage cable	ثقل شد كابل السحب	77 pylon, a framework support	برج
43 tension cable pulley	بكرة ثقل الشد	78 tubular steel pylon, a tubular steel support	برج أنبوبي من الصلب
44 suspension cable (supporting cable)	كابل التعليق	79 suspension cable guide rail (supporting cable guide rail, support guide rail)	قضيب دليلي لكابل التعليق
45 haulage cable	كابل السحب	80 support truss, a frame for work on the cable	كيفية دعم
46 balance cable (lower cable)	كابل موازنة (كابل سفلي)	81 base of the support	قاعدة الدعامة
47 auxiliary cable (emergency cable)	كابل إضافي (للطوارئ)		
48 auxiliary-cable tensioning mechanism (emergency-cable tensioning mechanism)	آلية شد كابل الطوارئ	215 Bridges	الجسور
49 haulage cable rollers	أسطوانات كابل السحب	1 cross-section of a bridge	مقطع عرضي للجسر
50 spring buffer (Am. spring bumper)	مصد معلق على نابض	2 orthotropic roadway (orthotropic deck)	طريق مستقيم
51 valley station platform (lower station platform)	رصيف المحطة الركبية	3 truss (bracing)	كيفية (تقوية بالشكالات)
52 cabin (cableway gondola, ropeway gondola, suspension line gondola), a large-capacity cabin	كابينة (كبيرة السعة)	4 diagonal brace (diagonal strut)	شكالات مائل
53 pulley cradle	محمل البكرات	5 hollow tubular section	جزء أنبوبي أجوف
54 suspension gear	آلية التعليق	6 deck slab	بلاط السطح
55 stabilizer	آلية موازنة	7 solid-web girder bridge (beam bridge)	جسر برافدة ذات وترة مضمنة
56 guide rail	قضيب دليلي	8 road surface	سطح الطريق
57 top station (upper station)	محطة علوية	9 top flange	شفة علوية
58 suspension cable guide (supporting cable guide)	دليل كابل التعليق	10 bottom flange	شفة سفلية
59 suspension cable anchorage (supporting cable anchorage)	إرساء كابل التعليق	11 fixed bearing	محمل ثابت
60 haulage cable rollers	أسطوانات كابل السحب	12 movable bearing	محمل متحرك
61 haulage cable guide wheel	عجلة دليلية لكابل السحب	13 clear span	باع، بحر الجسر
62 haulage cable driving pulley	بكرة دفع كابل السحب	14 span	مسافة ممتدة
63 main drive	الإدارة الرئيسية	15 rope bridge (primitive suspension bridge)	جسر كبلية/خيلية
64 standby drive	إدارة احتياطية	16 carrying rope	كابل/ حبل الحمل
65 control room	غرفة التحكم	17 suspension rope	كابل/ حبل التعليق
66 cabin pulley cradle	محمل بكرات الكابينة	18 woven deck (woven decking)	سطح جسر منسوج
67 main pulley caradle	محمل البكرات الرئيسي	19 stone arch bridge, a solid bridge	جسر عقدي/ قنطري حجري
68 double cradle	محمل مزدوج	20 arch	عقد، قنطرة
69 two-wheel cradle	محمل ذو عجلتين	21 pier	دعامة جسر
70 running wheels	عجلات التشغيل	22 statue	تمثال
		23 trussed arch bridge	جسر عقدي جملوني
		24 truss element	عضو جملوني
		25 trussed arch	عقد جملوني

26 arch span	باج/بدر العُقد	section, pivoting span,
27 abutment (end pier)	مُتَكَ الجسر	movable half) of bridge
28 spandrel-braced arch bridge	جسر عُقدي مَقوى بِعُرْوَة عُقدية	67 flat swing bridge
29 abutment (abutment pier)	مُتَكَ الجسر	68 middle section
30 bridge strut	رَكِيزَة الجسر	69 pivot
31 crown	تاج	70 parapet (handrailing)
32 covered bridge of the Middle Ages (the Ponte Vecchio in Florence)	جسر مغطى من طراز العصور الوسطى (جسر "بونت فيكسيو" في فلورنسا)	216 Rivers and River Engineering
33 goldsmiths' shops	محلات الصاغة	1 cable ferry (also: chain ferry), a passenger ferry
34 steel lattice bridge	جسر شبكي من الصلب	2 ferry rope (ferry cable)
35 counterbrace (cross-brace, diagonal member)	تكتيف مُتعارض	3 river branch (river arm)
36 vertical member	عُضْو رأسي	4 river island (river islet)
37 truss joint	وَصلة شد	5 collapsed section of riverbank, flood damage
38 portal frame	هَيْكل البوابة	6 motor ferry
39 suspension bridge	جسر مُعلق	7 ferry landing stage (motorboat landing stage)
40 suspension cable	كابل التعليق	8 pile foundations
41 suspender (hanger)	قضيب تعليق، علاقة	9 current (flow, course)
42 tower	برج	10 flying ferry (river ferry), a car ferry
43 suspension cable anchorage	إرشاء كابل التعليق	11 ferry boat
44 tied beam [with roadway]	كَمَرَة مشدودة [مع طريق معبدة]	12 buoy (float)
45 abutment	مُتَكَ الجسر	13 anchorage
46 cable-stayed bridge	جسر بشدادات كيبلية	14 harbour (Am. harbor) for laying up river craft
47 inclined tension cable	كابل شد مائل	15 ferry boat (punt)
48 inclined cable anchorage	إرشاء الكابل المائل	16 pole (punt pole, quant pole)
49 reinforced concrete bridge	جسر خرساني مسلح	17 ferryman
50 reinforced concrete arch	عقد من الخرسانة المسلحة	18 blind river branch (blind river arm)
51 inclined cable system (multiple cable system)	نظام كيبيلات مائلة	19 groyne (Am. groin)
52 flat bridge, a plate girder bridge	جسر مسطح	20 groyne (Am. groin) head
53 stiffener	عضادة، قطعة تقوية	21 fairway (navigable part of river)
54 pier	دعامة الجسر	22 train of barges
55 bridge bearing	مُحَل الجسر	23 river tug
56 cutwater	دعامة الجسر العبودية على مسار الماء	24 tow rope (tow line, towing hawser)
57 straits bridge, a bridge built of precast elements	جسر من أجزاء سابقة الصب	25 barge (freight barge, cargo barge, lighter)
58 precast construction unit	وحدة إنشاء سابقة الصب	26 bargeman (bargee, lighterman)
59 viaduct	قنطرة متعددة الركائز	27 towing (hauling, haulage)
60 valley bottom	قاع منفرج	28 towing mast
61 reinforced concrete pier	دعامة جسر خرسانية مسلحة	29 towing engine
62 scaffolding	الإسقالة	30 towing track; form.: tow path (towing path)
63 lattice swing bridge	جسر شبكي دوار	31 river after river training
64 turntable	صينية دَوّارة، قرص دَوّار	32 dike (dyke, main dike, flood wall, winter dike)
65 pivot pier	دعامة ارتكازية	
66 pivoting half (pivoting	نصف جسر متحرك	

33 drainage ditch	خندق صرف	217 Waterway and Hydraulic Engineering
34 dike (dyke) drainage sluice	بُوابة الصرف في جدار التهذيب	1-14 quay wall
35 wing wall	جدار الجانب (حائط جناح الحائط التي تُوّجه مجرى الماء)	1 road surface
36 outfall	مُخْرَج التصريف	2 body of wall
37 drain (infiltration drain)	صرف، بئر (صرف الترشيح)	3 steel sleeper
38 berm (berme)	سُطّاح	4 steel pile
39 top of dike (dyke)	قمة جدار التهذيب	5 sheet pile wall (sheet pile bulkhead, sheet piling)
40 dike (dyke) batter (dike slope)	مُحدّر جدار التهذيب	6 box pile
41 flood bed (inundation area)	قاع فيضان النهر	7 backfilling (filling)
42 flood containment area	منطقة حصر الفيضان	8 ladder
43 current meter	مقياس سرعة التيار	9 fender (fender pile)
44 kilometre (Am. kilometer) sign	علامة كيلومتر	10 recessed bollard
45 dikereeve's (dykereeve's) house (dikereeve's cottage); also: ferryman's house (cottage)	كشك مراكبية جدار التهذيب	11 double bollard
46 dikereeve (dykereeve)	مراكبي جدار التهذيب	12 bollard
47 dike (dyke) ramp	مُمرّ مُحدّر لجدار التهذيب سدّ صُنّعي	13 cross-shaped bollard (cross-shaped mooring bitt)
48 summer dike (summer dyke)	سدّ حاجز، ضفة الفيضان	14 double cross-shaped bollard (double cross-shaped mooring bitt)
49 levee (embankment)	أكياس رمل	15-28 canal
50 sandbags	وقاء الضفة، جدار احتجاز	15 & 16 canal entrance
51-55 bank protection (bank stabilization revetment)		15 mole
51 riprap	حجارة الدكة، ردم صخري	16 breakwater
52 alluvial deposit (sand deposit)	راسب غريني/طمي	17-25 staircase of locks
53 fascine (bundle of wooden sticks)	شدة قضبان مترابطة لِدَعْم الجدار	17 lower level
54 wicker fences	سياج من الأماليد	18 lock gate, a sliding gate
55 stone pitching	تَكسية بالديش	19 mitre (Am. miter) gate
56 floating dredging machine (dredger), a multi-bucket ladder dredge	كِرَاكَة عائمة	20 lock (lock chamber)
57 bucket elevator chain	سلسلة مرّفاع قادوسي	21 power house
58 dredging bucket	قادوس التهذيب	22 warping capstan (hauling capstan), a capstan
59 suction dredger (hydraulic dredger) with trailing suction pipe or barge sucker	كِرَاكَة ماصّة ذات أنبوب ماص خلفي	23 warp
60 centrifugal pump	مضخة نايدة	24 offices (e.g. canal administration, river police, customs)
61 back scouring valve	صمام تنظيف (كشج) خلفي	25 upper level (head)
62 suction pump, a jet pump with scouring nozzles	مضخة ماصة، مضخة نفثة ذات فوهات تنظيف	26 lock approach
		27 lay-by
		28 bank slope
		29-38 boat lift (Am. boat elevator)
		29 lower pound (lower reach)
		30 canal bed
		31 pound lock gate, a vertical gate
		32 lock gate
		33 boat tank (caisson)
		34 float
		35 float shaft
		36 lifting spindle
		القناة الملاحية
		والهندسة الهيدروليّة
		حائط الرصيف البحري
		سطح الطريق
		جسم الجدار
		راقدة صلب
		خازنوك صلب
		جدار سِتارة خازنوية
		خازنوك صُلْدوقي
		رِدْم
		سلم
		خازنوك الصند
		عمود غائر لِرَبط الجبال
		على الرصيف
		عمود ربط جبال مزدوج
		عمود ربط الجبال على الرصيف
		عمود ربط جبال صليبي
		عمود ربط جبال صليبي مزدوج
		قناة
		مدخل القناة
		بُوابة القناة
		مُظلم، حاجز أمواج
		سلم الهواويس
		المستوى السفلي
		بُوابة الهويس
		بُوابة زاوية
		هويس
		مُحطة الطاقة
		رَحوية جبال شدّ المراكب للمرساة
		جبل مشدود إلى مرسة
		مكاتب (مثال إدارة القناة، السُرطة النهرية، الجمارك)
		المستوى العلوي (رأس الهويس)
		مدخل الهويس
		مكان التوقف (غاطس)
		مُحدّر الضفّة
		مرّفاع القوارب
		اللسان السفلي
		قاع القناة
		بُوابة هويس اللسان
		بُوابة الهويس
		صهريج القوارب (قُيُوسون)
		عوامة، طُوف
		مِهْواة العوامة
		عمود رفع دَوّارني

37 upper pound (upper reach)	اللسان العلوي
38 vertical gate	بُوابة رأسيّة
39-46 pumping plant and reservoir	وحدة الضخّ والخزان
39 forebay	خليج أمامي
40 surge tank	صهريج الاتزان (منع التمور)
41 pressure pipeline	خط أنابيب ضغط
42 valve house (valve control house)	مبنى الصمامات
43 turbine house (pumping station)	مَحطّة التوربين (محطة الضخ)
44 discharge structure (outlet structure)	مبنى التفريغ
45 control station	مَحطّة التّحكّم
46 transformer station	مَحطّة المُحوّل
47-52 axial-flow pump (propeller pump)	مضخّة دافعة
47 drive motor	محرّك الإدارة
48 gear	تروس الحركة
49 drive shaft	عمود الإدارة
50 pressure pipe	أنبوب الضغط
51 suction head	رأس المصّ
52 impeller wheel	عجلة رفاضة (رفاص)
53-56 sluice valve (sluice gatc)	صمام بوابة التّحكّم في الصّرف
53 crank drive	إدارة عمود المرفق
54 valve housing	مبنى الصمامات
55 sliding valve (sliding gate)	صمام منزلق
56 discharge opening	فتحة الصّرف
57-64 dam (barrage)	سد (قنطرة)
57 reservoir (storage reservoir, impounding reservoir, impounded reservoir)	خزان (صهريج تخزين)
58 masonry dam	سدّ بناهي
59 crest of dam	قمة السّد
60 spillway (overflow spillway)	قناة تصريف الفائض
61 stilling basin (stilling box, stilling pool)	حوض تهدئة
62 scouring tunnel (outlet tunnel, waste water outlet)	نفق تنظيف/كسح (مصرف الماء الفائض)
63 valve house (valve control house)	مبنى الصمامات
64 power station	مَحطّة الطاقة
65-72 rolling dam (weir, a barrage; other system: shutterweir)	سدّ دوّار (قنطرة احتجاز)
65 roller, a barrier	حاجز، دولفين
66 roller top	قمة الحاجز
67 flange	شفة
68 submersible roller	دولفين غاطس
69 rack track	ممرّ مسنّن
70 recess	تجويف
71 hoisting gear cabin	كابينّة مُعدّات الرّفّع

72 service bridge (walk-way)	جسر خدمة (ممشى)
73-80 sluice dam	سدّ بقناة تصريف ذات بوابة تحكّم
73 hoisting gear bridge	جسر مُعدّات الرّفّع
74 hoisting gear (winding gear)	مُعدّات الرّفّع
75 guide groove	أخدود دليلي
76 counterweight (counterpoise)	ثقل موازن
77 sluice gate (floodgate)	بُوابة تحكّم (بوابة الهويس)
78 reinforcing rib	ضلع تقوية
79 dam sill (weir sill)	عتبة السّد
80 wing wall	حائط جناح الحائط التي توجّه مجرى الماء

218 Types of Historical Ship

1-6 Germanic rowing boat [ca. AD 400]; the Nydam boat	أنواع القوارب عبر العصور
1 stern post	قارب تجديف على الطراز الجرماني [400 م]
2 steersman	قارب "البيداه"
3 oarsman	عمود الكؤنل
4 stem post (stem)	موجّه الدفة
5 oar, for rowing	المجدف
6 rudder (steering oar), a side rudder, for steering	عمود الجؤنجؤ
7 dugout, a hollowed-out tree trunk	مجذاف
8 paddle	دفة التوجيه
9-12 trireme, a Roman warship	زورق شجري، جذع شجرة مجوف
9 ram	مجذاف
10 forecattle (fo'c'sle)	ثلاثية المجاديف، سفينة حربية رومانية
11 grapple (grapnel, grappling iron), for fastening the enemy ship alongside	الرام شبه منقار قوي معد للاختراق السفن المعادية السلولية
12 three banks (tiers) of oars	كلاب تثبتت سفينة الأعداء بجوار السفينة
13-17 Viking ship (long-ship, dragon ship) [Norse]	ثلاثة طوابق من المجاديف
13 helm (tiller)	سفينة الفاكينج [الاسكندنافيون]
14 awning crutch with carved horses' heads	مقبض دفة السفينة
15 awning	دعامة الظلة وبها رؤوس خيل منحوتة
16 dragon figurehead	ظلة
17 shield	تمثال في مقدمة السفينة
18-26 cog (Hansa cog, Hansa ship)	بشكل تين
18 anchor cable (anchor rope, anchor hawser)	ترس، درع
19 forecattle (fo'c'sle)	سفينة الهانسا
20 bowsprit	خيل/كيبيل المرسة
21 ured (brailed-up)	السلولية

square sail	راية المدينة
22 town banner (city banner)	أعلى مؤخرة السفينة
23 aftercastle (sterncastle)	دفة
24 rudder, a stem rudder	كؤنل مستدير/اهليجي
25 elliptical stern (round stern)	وقاء خشبي
26 wooden fender	سفينة شراعية سريعة
27-43 caravel (carvel) ["Santa Maria" 1492]	["سانتا ماريّا" 1492م]
27 admiral's cabin	كابينّة أمير البحر
28 spanker boom	ذراع تطويل شراع المؤخرة
29 mizzen (mizen, mutton spanker, lateen spanker), lateen sail	شراع المرزّين
30 lateen yard	عارضة الشراع المثث
31 mizzen (mizen) mast	صاري شراع المرزّين
32 lashing	رباط، وثاق
33 mainsail (main course), a square sail	الشراع الرئيسي
34 bonnet, a removable strip of canvas	وصلة في الشراع
35 bowline	الكؤنل
36 bunt line (martinet)	خيل متدود إلى أدنى الشراع
37 main yard	العارضة الرئيسية
38 main topsail	الشراع الثاني الرئيسي
39 main topsail yard	عارضة الشراع الثاني الرئيسي
40 mainmast	الصاري الرئيسي
41 foresail (fore course)	الشراع الأمامي
42 foremast	الصاري الأمامي
43 spritsail	الشراع المنشور
44-50 galley [15th to 18th century], a slave galley	القائدس سفينة شراعية ذات مجاديف [القرن 18-15 م]، سفينة عبدة فانوس كابينية
44 lantern	ممر سطح السفينة المركزي
45 cabin	سائق العبيد ويده السوط
46 central gangway	عبدة القائدس
47 slave driver with whip	منضّعة مغطاة في الجزء الأمامي من السفينة
48 galley slaves	مدفع
49 covered platform in the forepart of the ship	سفينة حربية [القرن 18 إلى القرن 19]، سفينة ذات ثلاثة أسطح
50 gun	ذراع تطويل شراع السارية الأمامية
51-60 ship of the line (line-of-battle ship) [18th to 19th century], a three-decker	شراع الدقل الأعلى الأمامي
51 jib boom	شراع الدقل الأعلى الرئيسي
52 fore topgallant sail	شراع الدقل الأعلى المرزّيني
53 main topgallant sail	كؤنل مرزّين بالذهب
54 mizzen (mizen) top-gallant sail	الكؤنل العلوي
55-57 gilded stern	شرفة الكؤنل
55 upper stern	شرفة الجانب القريب من
56 stern gallery	
57 quarter gallery, a	

projecting balcony with ornamental portholes	المؤخرة ذات نوافذ زينة
58 lower stern	الكؤنل السفلي
59 gunports for broadside fire	فتحات المدافع لإطلاق وابل من النيران
60 gunport shutter	مبلاق فتحة المدفع
219 Sailing Ship I	السفن الشراعية (1)
1-72 rigging (rig, tackle) and sails of a bark (barque)	حبال الأشرعة والصواري والأشرعة لقارب البرك (قارب بثلاثة صواري)
1-9 masts	الصواري
1 bowsprit with jib boom	الدقل المائل وذراع تطويل شراع السارية الأمامية
2-4 foremast	الصاري الأمامي
2 lower foremast	الصاري الأمامي السفلي
3 fore topmast	الدقل المتوسط الأمامي
4 fore topgallant mast	صاري الدقل الأعلى الأمامي
5-7 mainmast	الصاري الرئيسي
5 lower mainmast	الصاري الرئيسي السفلي
6 main topmast	الدقل الرئيسي المتوسط
7 main topgallant mast	صاري الدقل الأعلى الرئيسي
8 & 9 mizzen (mizen) mast	صاري المرزّين
8 lower mizzen (lower mizen)	المرزّين السفلي
9 mizzen (mizen) top-mast	الدقل المتوسط المرزّيني
10-19 standing rigging	حبال الأشرعة والصواري القائمة
10 forestay, mizzen (mizen) stay, mainstay	الحبل المثبت للشراع الرئيسي
11 fore topmast stay, main topmast stay, mizzen (mizen) topmast stay	الحبل المثبت للدقل المتوسط الأمامي
12 fore topgallant stay, mizzen (mizen) top-gallant stay, main top-gallant stay	الحبل المثبت للدقل الأعلى الأمامي
13 fore royal stay (main royal stay)	الحبل المثبت للشراع الأمامي الصغير
14 jib stay	الحبل المثبت لشراع السارية الأمامية
15 bobstay	حبل تثبيت الدقل المائل
16 shrouds	حبال الصاري
17 fore topmast rigging (main topmast rigging, mizzen (mizen) top-mast rigging)	حبال الأشرعة والصواري للدقل المتوسط الأمامي
18 fore topgallant rigging (main topgallant rigging)	حبال الأشرعة والصواري للدقل الرئيسي الأعلى الأمامي
19 backstays	الشكّال الخلفي
20-31 fore-and-aft sails	الأشرعة الأمامية والخلفية
20 fore topmast staysail	الشراع المثبت للدقل المتوسط الأمامي

21 inner jib	شراع السارية الأمامية الداخلي
22 outer jib	شراع السارية الأمامية الخارجي
23 flying jib	شراع السارية الأمامية المرفرف
24 main topmast staysail	الشراع المثبت للدقّل المتوسط الرئيسي
25 main topgallant staysail	الشراع المثبت للدقّل الأعلى الرئيسي
26 main royal staysail	الشراع المثبت الرئيسي الصغير
27 mizzen (mizen) staysail	الشراع المثبت المزيّني
28 mizzen (mizen) top-mast staysail	الشراع المثبت للدقّل المتوسط
29 mizzen (mizen) top-gallant staysail	الشراع المثبت المزيّني للدقّل الأعلى
30 mizzen (mizen, spanker, driver)	المزيّني
31 gaff topsail	الشراع العلوي للقريّة
32-45 spars	المسواري
32 foreyard	عارضه الشراع الأمامية
33 lower fore topsail yard	العارضه السفلية للدقّل المتوسط الأمامي
34 upper fore topsail yard	العارضه العلوية للدقّل المتوسط الأمامي
35 lower fore topgallant yard	العارضه السفلية للدقّل الأعلى الأمامي
36 upper fore topgallant yard	العارضه العلوية للدقّل الأعلى الأمامي
37 fore royal yard	عارضه الشراع الصغير الأمامي
38 main yard	العارضه الرئيسية
39 lower main topsail yard	العارضه السفلية للدقّل المتوسط الرئيسي
40 upper main topsail yard	العارضه العلوية للدقّل المتوسط الرئيسي
41 lower main topgallant yard	العارضه السفلية للدقّل الأعلى الرئيسي
42 upper main topgallant yard	العارضه العلوية للدقّل الأعلى الرئيسي
43 main royal yard	عارضه الشراع الرئيسي الصغير
44 spanker boom	ذراع شراع المؤخرة
45 spanker gaff	قريّة شراع المؤخرة
46 footrope	حبل سفلي
47 lifts	مرافع
48 spanker boom topping lift	المرافع العلوي لذراع تطويل شراع المؤخرة
49 spanker peak halyard	كرد قمة شراع المؤخرة
50 foretop	منصّة في أعلى الصاري الأمامي
51 fore topmast crosstrees	منصّات صاري الشراع العلوي الأمامي
52 maintop	المنصّة الرئيسية
53 main topmast crosstrees	منصّات صاري الشراع العلوي الرئيسي
54 mizzen (mizen) top	منصّة المزيّني
55-66 square sails	الأشرعة المربعة

55 foresail (fore course)	الشراع الأمامي
56 lower fore topsail	الشراع العلوي الأمامي المنخفض
57 upper fore topsail	الشراع العلوي الأمامي المرتفع
58 lower fore topgallant sail	الشراع السفلي للدقّل الأعلى الأمامي
59 upper fore topgallant sail	الشراع العلوي للدقّل الأعلى الأمامي
60 fore royal	الشراع الأمامي الصغير
61 mainsail (main course)	الشراع الرئيسي
62 lower main topsail	الشراع الرئيسي العلوي المنخفض
63 upper main topsail	الشراع الرئيسي العلوي المرتفع
64 lower main topgallant sail	الشراع السفلي للدقّل الأعلى الرئيسي
65 upper main topgallant sail	الشراع العلوي للدقّل الأعلى الرئيسي
66 main royal sail	الشراع الصغير الرئيسي
67-71 running rigging	حبال الأشرعة والمسواري المتحركة
67 braces	شكالات
68 sheets	ألواح
69 spanker sheet	لوح شراع المؤخرة
70 spanker vangs	حبال تثبيت القريّة
71 bunt line	خط منتصف الشراع
72 reef	ثنية الشراع
220 Sailing Ship II	السفن الشراعية (2)
1-5 sail shapes	أشكال الشراع
1 gaffsail (small: trysail, spencer)	شراع القريّة (الصغير)
2 jib	شراع المؤصف
3 lateen sail	شراع السارية الأمامية
4 lugsail	شراع مثلث الشكل
5 spritsail	شراع رباعي الأضلاع المتوسط المنشور (على عمود القلع)
6-8 single-masted sailing boats (Am. sailboats)	القوارب الشراعية وحيدة الصاري
6 tjalk	قارب من طراز "التجلك"
7 leeboard	لوح جانب السفينة المحجوب عن الريح
8 cutter	قارب من طراز "كاتر"
9 & 10 mizzen (mizen) masted sailing boats (Am. sailboats)	القوارب الشراعية ذات الصاري المزيّني
9 ketch-rigged sailing barge	صنّدل شراعي بشراعتين
10 yawl	قارب طراز "يول"
11-17 two-masted sailing boats (Am. sailboats)	القوارب الشراعية ثنائية الصاري
11-13 topsail schooner	سكوتر الدقّل المتوسط
11 mainsail	الشراع الرئيسي
12 boom foresail	الشراع الأمامي بذراع التطويل
13 square foresail	شراع أمامي مربع
14 brigantine	سفينة شراعية بصاريين طراز "بريجانتين"

15 half-rigged mast with fore-and-aft sails	قارب شراعي بصاري نصف مزود بالأشرعة وله شراع أمامي وآخر خلفي صاري مزود بالأشرعة كاملة وعليه أشرعة مربعة سفينة شراعية بصاريين طراز "بريج"
16 full-rigged mast with square sails	سفينة شراعية بثلاثية الصواري
17 brig	سكوتر ثلاثي الصواري
18-27 three-masted sailing vessels (three-masters)	سكوتر ثلاثي الصواري
18 three-masted schooner	سكوتر ثلاثي الصواري ذو شراع علوي
19 three-masted topsail schooner	سكوتر الثلاث الصواري ذو قارب البرك
20 bark (barque) schooner	سكوتر الثلاث الصواري ذو قارب البرك
21-23 bark (barque) [cf. illustration of rigging and sails in plate 219]	القارب البرك
21 foremast	الصاري الأمامي
22 mainmast	الصاري الرئيسي
23 mizzen (mizen) mast	صاري المزيّني
24-27 full-rigged ship	سفينة مزودة بالأشرعة بالكامل
24 mizzen (mizen) mast	صاري المزيّني
25 crossjack yard (crojack yard)	عارضه شراع ذات عمود تدعيم تصالبي
26 crossjack (crojack)	عمود تصالبي لدعم الشراع
27 ports	فتحات السفينة
28-31 four-masted sailing ships (four-masters)	سفن شراعية رباعية الصواري
28 four-masted schooner	سكوتر رباعي الصواري
29 four-masted bark (barque)	برك رباعي الصواري
30 mizzen (mizen) mast	صاري المزيّني
31 four-masted full-rigged ship	سفينة رباعية الصواري مزودة بكامل الأشرعة
32-34 five-masted bark (barque)	برك خماسي الصواري
32 skysail	الشراع السماوي
33 middle mast	الصاري الأوسط
34 mizzen (mizen) mast	صاري المزيّني
35-37 development of sailing ships over 400 years	تطور السفن الشراعية طوال 400 عام
35 five-masted full-rigged ship "Preussen" 1902-10	سفينة خماسية الصواري مزودة بكامل الأشرعة طراز "برويسن" عام 1902-1910
36 English clipper ship "Spindrift" 1867	سفينة انجليزية طراز "سبندرift" عام 1867
37 caravel (carvel) "Santa Maria" 1492	سفينة شراعية طراز "سانتا ماريا" عام 1492
221 Types of Ship	أنواع السفن
1 ULCC (ultra-large crude carrier) of the 'all-afit' type	ناقلة نفط عملاقة من الطراز الخلفي
2 foremast	الصاري الأمامي
3 catwalk with pipes	ممر ضيق وبه أنابيب
4 fire gun (fire nozzle)	مدفع إطفاء الحريق

5 deck crane	مرقاع سَطَع الناقله
6 deckhouse with bridge	بيت السطح وبه منصّة ريان السفينة
7 aft signal (signalling) and radar mast	صاري الاشارات الخلفي والرادار
8 funnel	مدخنة
9 nuclear research ship "Otto Hahn", a bulk carrier	سفينة أبحاث نووية طراز "أوهان"
10 aft superstructure (engine room)	أجزاء السفينة فوق السطح الرئيسي الخلفي (غرفة المحرك)
11 cargo hatchway for bulk goods (bulk cargoes)	فتحة إدخال الحمولة السائبة/ الضخمة
12 bridge	منصّة ريان السفينة
13 forecastle (fo'c'sle)	السفينة
14 stem	مقدم السفينة (الجوّج)
15 seaside pleasure boat	قارب تنزه
16 dummy funnel	مدخنة دمية
17 exhaust mast	صاري العادم
18 rescue cruiser	طراد إنقاذ
19 helicopter platform (working deck)	منصّة هبوط الهليكوبتر
20 rescue helicopter	طائرة هليكوبتر لعمليات الإنقاذ
21 all-container ship	سفينة حاويات
22 containers stowed on deck	حاويات مرصوصة على السطح
23 cargo ship	سفينة بضائع
24-29 cargo gear (cargo-handling gear)	معدات الشحن
24 bipod mast	صاري ثنائي المنصب
25 jumbo derrick boom (heavy-lift derrick boom)	ذراع مرقاع عملاق
26 derrick boom (cargo boom)	ذراع مرقاع (ذراع حمل البضائع)
27 tackle	بكارة (أجهزة الرفع)
28 block	بكارة
29 thrust bearing	محمّل دفعي
30 bow doors	أبواب الجوّج
31 stern loading door	باب كؤل السفينة لإدخال البضائع
32 offshore drilling rig supply vessel	سفينة تموين جهاز الحفر البحري
33 compact superstructure	أجزاء السفينة فوق السطح الرئيسي
34 loading deck (working deck)	سطح التحميل
35 liquefied-gas tanker	ناقله الغاز المسيل
36 spherical tank	خزان كروي
37 navigational television receiver mast	سارية استقبال تليفزيوني
38 vent mast	سارية التهوية
39 deckhouse	بيت السطح
40 funnel	مدخنة
41 ventilator	وحدّ التهوية
42 transom stern (transom)	كؤل بعارضه أفقية
43 rudder blade (rudder)	راحة الدفة (الدفة)

44 ship's propeller (ship's screw)	رَفَاصُ السفينة	83 stem	مَقْدَمُ السفينة (الجَوْجُو)
45 bulbous bow	جَوْجُو متنفخ	84 funnel with lattice casing	مدخنة ذات غلاف شبكي
46 steam trawler	ترولة بخارية	85 flag dressing (rainbow dressing, string of flags extending over masts-heads, e.g., on the maiden voyage)	حبل الرايات
47 lightship (light vessel)	مَتَارَة عائمة	86 trawler, a factory ship	سفينة الترولة
48 lantern (characteristic light)	فانوس	87 gallows	هيكَل قائم
49 smack	قارب السَّمَاك	88 stern ramp	مَمَرٌ مُخْتَرٌ بالكُؤُلُ
50 ice breaker	كَسَّارَةُ الجليد	89 container ship	سفينة حاويات
51 steaming light mast	سارية الأنوار البخاريَّة	90 loading bridge (loading platform)	جسر الشحن
52 helicopter hangar	حظيرة الهليكوبتر	91 sea ladder (jacob's ladder, rope ladder)	سلمٌ من الحبال ذو درجات خشبية
53 stern towing point, for gripping the bow of ships in tow	مَوْضِع قَطْر الكُؤُلُ لربط مقدمة السفينة المقطورة	92 barge and push tug assembly	صندل ومجموعة القَطْر الدفعي
54 roll-on-roll-off (ro-ro) trailer ferry	مُعَدِّيَّة قَطْر	93 push tug	قَطْر دفعي
55 stern port (stern opening) with ramp	فتحة الكُؤُلُ وبها مجرى مائل	94 tug-pushed dumb barge (tug-pushed lighter)	صندل مقطورة بالدفع
56 heavy vehicle lifts (Am. heavy vehicle elevators)	مرافع عربات ثقيلة	95 pilot boat	زُورق استطلاع
57 multi-purpose freighter	سفينة شحن متعددة الأغراض	96 combined cargo and passenger liner	عِبَّارَة نقل البضائع والركاب
58 ventilator-type samson (sampsom) post (ventilator-type king post)	دِعَامَة رئيسية ذات مَهْوَاة	97 passengers disembarking by boat	إنزال الركاب بالقارب
59 derrick boom (cargo boom, cargo gear cargo-handling gear)	ذراع الرِّفَاع (أجهزة الرفع)	98 accommodation ladder	السُّلَمُ المَدَلَاة
60 derrick mast	سارية ذراع الرِّفَاع	99 coaster (coasting vessel)	الساحلية، سفينة ساحلية
61 deck crane	مِرْفَاع سَطْح السفينة	100 customs or police launch	لائش الجمارك أو الشرطة
62 jumbo derrick boom (heavy-lift derrick boom)	ذراع مِرْفَاع عملاق	101-128 excursion steamer (pleasure steamer)	سفينة رحلات ترفيهية
63 cargo hatchway	فتحة شحن/تفريغ البضائع	101-106 lifeboat launching gear	مُعَدَّات قارب الإنقاذ
64 semisubmersible drilling vessel	سفينة حفر شبه غاطسية	101 davit	الدَّاوودي
65 floating vessel with machinery	سفينة طافية وعليها المَعَدَّات	102 wire rope span	مسافة بين حبلين سلكيين
66 drilling platform	مِنَصَّة الحفر	103 lifeline	حبل الأبتعاد
67 derrick	بِرْج الحفر	104 tackle	بَكَارَة
68 cattleship (cattle vessel)	سفينة نقل الماشية	105 block	بِكْرَة
69 superstructure for transporting livestock	أجزاء سَطْح السفينة المخصصة لنقل الماشية	106 fall	حبل الرفع
70 fresh water tanks	خَزَانَات ماء الشرب	107 ship's lifeboat (ship's boat) covered with tarpaulin	قارب النجاة بالسفينة مغطى بقمعاش التربولين
71 fuel tank	خَزَان الوقود	108 stem	مَقْدَمُ السفينة (الجَوْجُو)
72 dung tank	خَزَان الروث	109 passenger	راكب
73 fodder tanks	خَزَانَات العلف	110 steward	مُضَيِّف
74 train ferry [cross section]	مُعَدِّيَّة قطاريَّة [قطاع عرضي]	111 deck-chair	كُرْسِي سَطْح السفينة
75 funnel	مدخنة	112 deck hand	عامل تنظيف سَطْح السفينة
76 exhaust pipes	أنابيب العادم	113 deck bucket	دَبُو تنظيف سَطْح السفينة
77 mast	سارية	114 boatswain (bo's'n, bo'sun, bosun)	عريف الملاحين
78 ship's lifeboat hanging at the davit	قارب نجاة معلق بالدَّاوودي	115 tunic	سترة ضيقة
79 car deck	سَطْح السيارات	116 awning	ظَلَّة، ندفة
80 main deck (train deck)	السَطْح الرئيسي	117 stanchion	دِعَامَة قائمة
81 main engines	المحركات الرئيسية	118 ridge rope (jackstay)	قضيب تشد إليه الظلَّة
82 passenger liner (liner, ocean liner)	عِبَّارَة نقل الركاب		

119 lashing	رباط، وثاق	24 crane rails (crane track)	قضبان انزلاق المِرْفَاع المتقل
120 bulwark	جانِب السفينة الممتد فوق سطحها العلوي	25 gantry crane	مِرْفَاع قَنْطَرِي
121 guard rail	قَضِيْب وَاق	26 gantry (bridge)	قَنْطَرَة
122 handrail (top rail)	دِرابِيزِن	27 trestles (supports)	مساند، حوامل
123 companion ladder (companionway)	دَرَج	28 crab (jenny)	كِبَّاش المِرْفَاع (عربة مدر فاع نقالية)
124 lifebelt (lifebuoy)	طُوق النجاة	29 hull frames in position	هياكل بَدَن السفينة بعد تركيبها
125 lifebuoy light (lifebelt light, signal light)	لَمْبَة طُوق النجاة	30 ship under construction	سفينة تحت الإنشاء
126 officer of the watch (watchkeeper)	ضابط المناوبة	31-33 dry dock	حوض الإنشاء، حَوْض جاف
127 reefer (Am. pea jacket)	سِتْرَة ضيقة من قماش سميك	31 dock floor (dock bottom)	أرضية الحَوْض
128 binoculars	نظارة مكبِّرة، ناظور	32 dock gates (caisson)	بوابة الحوض (قيسون)
222 Shipbuilding	بِنَاء السُّفُن	33 pumping station (power house)	مُحَطَّة الضخ (مُحَطَّة الطاقة)
1-43 shipyard (shipbuilding yard, dockyard, Am. navy yard)	مُسْنَفِن، ترسانة بناء السفن	34-43 floating dock (pontoon dock)	رصيف عائِم
1 administrative offices	مكاتب إدارية	34 dock crane (dockside cranc), a jib crane	مِرْفَاع الرصيف، مِرْفَاع ذراعي
2 ship-drawing office	مكتب رسم السفن	35 fender pile	خازوق يَمَد
3 & 4 shipbuilding sheds	عناير بناء السفن	36-43 working of docks	تشكيل الرصيف
3 mould (Am. mold) loft	علية التشكيل	36 dock basin	حَوْض الرصيف
4 erection shop	وَرشَة التركيب	37 & 38 dock structure	هيكَل الرصيف
5-9 fitting-out quay	رصيف تجهيز	37 side tank (side wall)	صهريج جانبي (جدار جانبي)
5 quay	رصيف	38 bottom tank (bottom pontoon)	صهريج سفلي (طُوف سفلي)
6 tripod crane	مرفاع ثلاثي القوائم	39 keel block	كتلة صالِب القاعدة
7 hammer-headed crane	مِرْفَاع كَابُولِي عملاق	40 bilge block (bilge shore, side support)	كتلة الجَمَّة
8 engineering workshop	وَرشَة هندسية	41-43 docking a ship	سحب السفينة إلى الرصيف
9 boiler shop	وَرشَة تصليح المَرَاكِل	41 flooded floating dock	حَوْض عائِم مغمور
10 repair quay	رصيف التصليح	42 tug towing the ship	سفينة قَطْر تسحب السفينة
11-26 slipways (slips, building berths, building slips, stocks)	رصيف إنزال أو إنشاء مُحدَر	43 emptied (pumped-out) dock	رصيف مَفْرَع
11-18 cable crane berth, a slipway (building berth)	رصيف المِرْفَاع الكِبيلي	44-61 structural parts of the ship	الأجزاء الهيكلية للسفينة
11 slipway portal	رصيف إنزال (أو إنشاء) قَنْطَرِي	44-56 longitudinal structure	الهيكل الطولي
12 bridge support	دِعَامَة جِسْر	44-49 shell (shell plating, skin)	القشرة
13 crane cable	كَبيل المِرْفَاع	44 shear strake	لُوح طولي عمودي
14 crab (jenny)	كِبَّاش المِرْفَاع (عربة مِرْفَاع نقالية)	45 side strake	لُوح طولي جانبي
15 cross piece	قطعة مستعرضة	46 bilge strake	لُوح طولي لِحْمَة السفينة
16 crane driver's cabin (crane driver's cage)	كابينَة سائق المِرْفَاع	47 bilge keel	رافدة الجَمَّة في السفينة
17 slipway floor	أرضية رصيف	48 bottom plating	ألواح القاع
18 staging, a scaffold	الإنزال/الإنشاء	49 flat plate keel (keel plate)	لُوح الصالِب
19-21 frame slipway	سقالة، إسقالة	50 stringer (side stringer)	ضلع طولاني، عارضة
19 slipway frame	هيكلي	51 tank margin plate	لُوح حافة الخَزَان
20 overhead travelling (Am. traveling) crane (gantry crane)	هيكَل/إطار الرصيف	52 longitudinal side girder	عارضة طولية جانبية
21 slewing crab	مِرْفَاع علوي متحرك (مِرْفَاع قَنْطَرِي)	53 centre (Am. center) plate girder (centre girder, kelson, keelson, vertical keel)	عارضة لُوحِيَّة مركزية
22 keel in position	عربة مِرْفَاع نقالية نُوَارَة		
23 luffing jib crane, a slipway crane	رافدة القص بعد تركيبها مِرْفَاع بذراع سفلي المتفصل		

top, inner bottom plating)	rotatable loop antenna, aural null loop antenna)
55 centre (<i>Am. center</i>) strake	6 magnetic compass (mariner's compass)
56 deck plating	7 morse lamp (signalling, <i>Am. signaling, lamp</i>)
57 deck beam	8 radar antenna (radar scanner)
58 frame (rib)	9 code flag signal
59 floor plate	10 code flag halyards
60 cellular double bottom	11 triatic stay (signal stay)
61 hold pillar (pillar)	12-18 bridge deck (bridge)
62 & 63 dunnage	12 radio room
64 side battens (side ceiling, spar ceiling)	13 captain's cabin
63 ceiling (floor ceiling)	14 navigating bridge
64, 65 hatchway	15 starboard sidelight [green; port sidelight red]
64 hatch coaming	16 wing of bridge
65 hatch cover (hatch-board)	17 shelter (weather cloth, dodger)
66-72 stern	18 wheelhouse
66 guard rail	19-21 boat deck
67 bulwark	19 ship's lifeboat
68 rudder stock	20 davit
69, 70 Oertz rudder	21 officer's cabin
69 rudder blade (rudder)	22-27 promenade deck
70 & 71 stern frame	22 sun deck (lido deck)
70 rudder post	23 swimming pool
71 propeller post (screw post)	24 companion ladder (companionway)
72 ship's propeller (ship's screw)	25 library (ship's library)
73 draught (draft) marks	26 lounge
74-79 bow	27 promenade
74 stem, a bulbous stem (bulbous bow)	28-30 A-deck
75 hawse	28 semi-enclosed deck space
76 hawse pipe	29 double-berth cabin, a cabin
77 anchor cable (chain cable)	30 de luxe cabin
78 stockless anchor (patent anchor)	31 ensign staff
79 stocked anchor	32-47 B-deck (main deck)
223 Motor Ship	32 after deck
1-71 combined cargo and passenger ship [of the older type]	33 poop
1 funnel	34 deckhouse
2 funnel marking	35 samson (sampson) post (king post)
3 siren (fog horn)	36 derrick boom (cargo boom)
4-11 compass platform (compass bridge, compass flat, monkey bridge)	37 crosstrees (spreader)
4 antenna lead-in (antenna down-lead)	38 crow's nest
5 radio direction finder (RDF) antenna (direction finder antenna,	39 topmast
	40 forward steaming light
	41 ventilator lead
	42 galley (caboose, cook-room, ship's kitchen)

43 ship's pantry	مُخَزَّن مَوْن السَّفِينَة	3 index bar (index arm)	قضيب دليلي
44 dining room	قاعة الطعام	4 decimal micrometer	ميكرومتر عشري
45 purser's office	مكتب مسئول السفينة	5 vernier	وزنية
46 single-berth cabin	كابينية بسريور مفرد	6 index mirror	مرآة دليلية
47 foredeck	السُّطْح الأمامي (سُّطْح مَقْدَم السفينة)	7 horizon glass (horizon mirror)	مرآة الأفق
48 forecastle (fo'c'sle)	السُّلُوقِيَّة عَبرَ أَمَامِي لِلخَبَّارة	8 telescope	تليسكوب
49-51 ground tackle	البِكَارَة الأَرْضِيَّة	9 grip (handgrip)	قبضة، مقبض
49 windlass	مِرْفَاع المِرْسَاة	10-13 radar equipment (radar apparatus)	معدّات الرادار
50 anchor cable (chain cable)	كَبِيل المِرْسَاة	10 radar pedestal	قاعدة الرادار
51 compressor (chain compressor)	ضامِط (ضامِط سلسلي)	11 revolving radar reflector	عاكس راداري دَوَّار
52 anchor	مِرْسَاة	12 radar display unit (radar screen)	شاشة الرادار (وَحْدَة عَرَض راداريَّة)
53 jackstaff	سارية العلم	13 radar image (radar picture)	صورة رادارية
54 jack	علم، راية	14-38 wheelhouse	حجرة مدير الدفة
55 after holds	العُتَابِر/الأَنْبَار الخلفية	14 steering and control position	مَوْجِع التوجيه والتحكّم
56 cold storage room (insulated hold)	عَبرِ التَحْزِين البَارِد (عَبرِ مَعزُول حراريًا)	15 ship's wheel for controlling the rudder mechanism	عَجَلَة التَحكّم فِي أَلِيَّة الدَّفَة
57 store room	حِجْرَة تَحْزِين (مخزن)	16 helmsman (<i>Am. wheelsman</i>)	مَوْجِه الدَّفَة
58 wake	أَثْرُ المَخر	17 rudder angle indicator	مُبيِّن زاوية الدَّفَة
59 shell bossing (shaft bossing)	صِنْرَة عَمود التَدوير	18 automatic pilot (autopilot)	المُرْسِد المَلاحِي الأَلي
60 tail shaft (tail end shaft)	عَمود تَدوير خَلْفِي	19 control lever for the variable-pitch propeller (reversible propeller, feathering propeller, feathering screw)	ذراع التَحكّم فِي رِفَاص الخَطوَة المَتبادِلَة
61 shaft strut (strut, spectacle frame, propeller strut, propeller bracket)	كُتِفِيَّة العَمود (كُتِفِيَّة الرِفَاص)	20 propeller pitch indicator	مُبيِّن خَطوَة الرِفَاص
62 three-blade ship's propeller (ship's screw)	رِفَاص ذو ثَلَاث أَرِياش	21 main engine revolution indicator	مُؤشِر دَوْرَات المَحرَك الرَئيسِي
63 rudder blade (rudder)	كَلَّة الدَّفَة	22 ship's speedometer (log)	عَدَاد سَرعَة السَّفِينَة
64 stuffing box	سَمِيكَة، صَفدوق حَشو	23 control switch for bow thruster (bow-manoeuvring, <i>Am. maneuvering, propeller</i>)	مِفْتَاح التَحكّم الخَاص بِرِفَاص الجَوِّجِي
65 propeller shaft	عَمود الرِفَاص	24 echo recorder (depth recorder, echograph)	مُسَجِّل العَمق الصَوْتِي
66 shaft alley (shaft tunnel)	نَفق عَمود التَدوير	25 engine telegraph (engine order telegraph)	مُبرِّقَة، تَلغِراف
67 thrust block	مِجموعَة/كَلتَة الدَفِع	26 controls for the anti-rolling system (for the stabilizers)	مُضامِط نِظام مَقاوِمَة التَمَائِل
68-74 diesel-electric drive	دَفِع دِيژَل-كَهْرَبِي	27 local-battery telephone	هَاتِف بِبطاريَة مَحليَّة
68 electric engine room	حِجْرَة المَحرَك الكَهْرَبِي	28 shipping traffic radio telephone	هَاتِف لاسلكي لِحَرَكة الشِحن
69 electric motor	مَحرَك كَهْرَبِي	29 navigation light indicator panel (running light indicator panel)	لُوحَة مَوسِرات لَمَبَات المِلاحَة
70 auxiliary engine room	حِجْرَة المَحرَكَات الإِضافِيَّة	30 microphone for ship's address system	مِيكروفون السَّفِينَة
71 auxiliary engines	مَحرَكَات إِضافِيَّة	31 gyro compass (gyroscopic compass), a compass repeater	بُؤصَلَة جِيروسكوبيَّة
72 main engine room	حِجْرَة المَحرَك الرَئيسِي		
73 main engine, a diesel engine	المَحرَك الرَئيسِي، مَحرَك دِيژَل		
74 generator	مُولِد كَهْرَبائي		
75 forward holds	العُتَابِر/الأَنْبَار الأَمَامِيَّة		
76 tween deck	سَطْح بَينِي		
77 cargo	بِضائِع		
78 ballast tank (deep tank) for water ballast	خَزَان الصابورة المائيَّة		
79 fresh water tank	خَزَان مَاء الشِرب		
80 fuel tank	خَزَان الوَقود		
81 bow wave	مَوْجَة الجَوِّجِي		
224 Navigation	المَلاحَة		
1 sextant	سُدسِيَّة		
2 graduated arc	قَوَس مَدْرَج		

32 control button for the ship's siren (ship's fog horn)	زِر تشغيل سارينة السفينة	impulse)
33 main engine overload indicator	مؤشّر الحمل الزائد على المحرّك الرئيسي	63 echo (sound echo, echo signal)
34 Decca position-finder (Decca Navigator)	مُحدّد المواقع بطريقة "ديكا"	64 echo receiver (hydrophone)
35 rough focusing indicator	مؤشّر التركيز البؤري التقريبي	65 echograph (echo sounding machine recorder)
36 fine focusing indicator	مؤشّر التركيز البؤري الدقيق	66 depth scale
37 navigating officer	ضابط ملاح	67 echogram (depth recording, depth reading)
38 captain	رَبَّانُ السفينة	68-108 sea marks (floating navigational marks) for buoyage and lighting systems
39 Decca navigation system	نظام الملاحة "ديكا"	68-83 fairway marks (channel marks)
40 master station	المَحْطَة الرئيسية	68 light and whistle buoy
41 slave station	مَحْطَة تابعة	69 light (warning light)
42 null hyperbola	قطع زائد صفرّي	70 whistle
43 hyperbolic position line 1	الخط 1 لموضع القطع الزائد	71 buoy
44 hyperbolic position line 2	الخط 2 لموضع القطع الزائد	72 mooring chain
45 position (fix, ship fix)	مَوْضِع السفينة	73 sinker (mooring sinker)
46-53 compasses	الموصلات	74 light and bell buoy
46 liquid compass (fluid compass, spirit compass, wet compass), a magnetic compass	بَوْضَلَة سائلة ، بوصلة مغناطيسية	75 bell
47 compass card	قَرَص البَوْضَلَة	76 conical buoy
48 lubber's line (lubber's mark, lubber's point)	خَط البَوْضَلَة البحرية	77 can buoy
49 compass bowl	تجويف البَوْضَلَة	78 topmark
50 gimbal ring	حلقة تثبيّت البَوْضَلَة في وضع أفقي	79 spar buoy
51-53 gyro compass (gyroscopic compass, gyro compass unit)	بَوْضَلَة جيروسكوبية	80 topmark buoy
51 master compass (master gyro compass)	بَوْضَلَة رئيسية	81 lightship (light vessel)
52 compass repeater (gyro repeater)	معيد البَوْضَلَة (للتقوية)	82 lantern mast (lantern tower)
53 compass repeater with pelorus	معيد البَوْضَلَة مع عضادة انعكاسية	83 beam of light
54 patent log (screw log, mechanical log, towing log, taffrail log, speedometer)	مقياس سرعة السفينة	84-102 fairway markings (channel markings)
55 rotator	دَوّار	84 wreck [green buoys]
56 governor	ضابط (سرعة) اوتوماتي	85 wreck to starboard
57 log clock	ساعة مقياس السرعة	86 wreck to port
58-67 leads	أثقال الفاندين	87 shoals (shallows, shallow water, Am. flats)
58 hand lead	فادن (تقلّ رصاصي) يدوي	88 middle ground to port
59 lead (lead sinker)	فادن غاطس	89 division (bifurcation) [beginning of the middle ground; top-mark: red cylinder above red ball]
60 headline	حَبْل الفاندين	90 convergence (confluence) [end of the middle ground; top-mark: red St. Antony's cross above red ball]
61-67 echo sounder (echo sounding machine)	مستنيار بالصدى	91 middle ground
61 sound transmitter	مُرْسِل الصوت	92 main fairway (main navigable channel)
62 sound wave (sound	مَوْجَة صوتية	

93 secondary fairway (secondary navigable channel)	مَجْرَى مائي ثانوي	11 harbour (Am. harbor)
94 can buoy	طافية ضخمة مخروطية الشكل	مُعَدّيّة المرفأ
95 port hand buoys (port hand marks) [red]	طافيات يدوية إلى يسار السفينة [أحمر]	12 fender (dolphin)
96 starboard hand buoys (starboard hand marks) [black]	طافيات يدوية إلى اليمين السفينة [أسود]	حاجز اصطدام
97 shoals (shallows, shallow water, Am. flats) outside the fairway	مياه ضحلة خارج المَجْرَى المائي	13 bunkering boat
98 middle of the fairway (mid-channel)	منتصف المَجْرَى المائي	قارب تزويد السفن بالوقود
99 starboard markers [inverted broom]	علامات اليمين	14 break-bulk carrier (general cargo ship)
100 port markers [upward-pointing broom]	علامات الجانب الأيسر	حاملة بضائع عامة الأغراض
101 & 102 range lights (leading lights)	أضواء إرشادية	15 tug
101 lower range light (lower leading light)	أضواء إرشادية سفلية	سفينة قتل
102 higher range light (higher leading light)	أضواء إرشادية أكثر ارتفاعاً	16 floating dock (pontoon dock)
103 lighthouse	فنار ، منارة	حوض سفن عائم
104 radar antenna (radar scanner)	هوائي رادار (ماسح راداري)	17 dry dock
105 lantern (characteristic light)	فانوس	حوض سفن جاف
106 radio direction finder (RDF) antenna	هوائي مُحدّد الاتجاه اللاسلكي	18 coal wharf
107 machinery and observation platform (machinery and observation deck)	مَبْنَى الآلات والملاحظة	رصيف الفحم
108 living quarters	وَحَدَات معيشة	19 coal bunker
225 Docks, Port, Harbour (Am. Harbor) (1)	أحواض السُفن والميناء والمرقا (1)	20 transporter loading bridge
1 dock area	منطقة حوض السفن	جسر تحميل نقال
2 free port (foreign trade zone)	ميناء حرة	21 quayside railway
3 free zone frontier (free zone enclosure)	حد المنطقة الحرة	سكة حديدية بجانب الرصيف
4 customs barrier	حاجز المنطقة الجمركية	22 weighing bunker
5 customs entrance	مدخل المنطقة الجمركية	مُخَرّج الوزن
6 port custom house	مبنى جمارك الميناء	23 warehouse
7 entrepôt	مستودع بضائع ، مخزن صندل	مستودع
8 barge (dumb barge, lighter)	عَبْر ترانزيت عام للبضائع	24 quayside crane
9 break-bulk cargo transit shed (general cargo transit shed, package cargo transit shed)		لانش وصندل تقريخ / شحن
10 floating crane	مرقا عائم	مستشفى الميناء
		26 port hospital
		27 quarantine wing
		28 Institute of Tropical Medicine
		29 excursion steamer (pleasure steamer)
		30 jetty
		31 passenger terminal
		32 liner (passenger liner, ocean liner)
		33 meteorological office, a weather station
		34 signal mast (signalling mast)
		35 storm signal
		36 port administration offices
		37 tide level indicator
		38 quayside road (quayside roadway)
		39 roll-on roll-off (ro-ro) system (roll-on roll-off operation)
		40 gantry
		41 truck-to-truck system (truck-to-truck operation)
		42 foil-wrapped unit loads
		43 pallets
		44 forklift truck (fork truck, forklift)
		45 container ship
		46 transporter container-loading bridge
		47 container carrier truck
		48 container terminal (container berth)

49 unit load	وَحْدَةُ الصَّلِّ	cargo	مركبة إحتكام التغليف	53 crane framework	هيكل المرفأع	30 main manoeuvring (<i>Am.</i> maneuvering) keel	صالب القاعدة الرئيسي للمناورة
50 cold store	بِرْدَانَةٌ	12 heat sealing machine	حرارية	54 winch house	مبيت الومش		
51 conveyor belt (conveyor)	سَبْرٍ نَاقِل	13 break-bulk carrier (general cargo ship)	سفينة بضائع عامة	55 control platform	منصة التحكم	228 Life Saving	إِنقَاذ الحَيَاة
52 fruit storage shed (fruit warehouse)	عَبْرٌ تَخزِين الفاكهة	14 cargo hatchway	فتحة إنزال البضائع من السفينة	56 turntable	صينية دَوَّارَةٌ	1 rocket apparatus (rocket gun, line-throwing gun)	جهاز صاروخي (مدفع رمي الخبل)
53 office building	مبني المكاتب	15 receiving truck on board ship	شاحنة الاستقبال على ظهر السفينة	57 pontoon, a pram	طُوف	2 life rocket (rocket)	صاروخ خبل الإنقاذ
54 urban motorway (<i>Am.</i> freeway)	طريق العربات	16 multi-purpose terminal	منصة متعددة الاغراض	58 engine superstructure (engine mounting)	حامل المحرك	3 rocket line (whip line)	خبل الصاروخ
55 harbour (<i>Am.</i> harbor) tunnels	أنفاق المرفأ	17 roll-on roll-off ship (ro-ro-ship)	سفينة تحميل وتفريغ			4 oilskins	ملابس من قماش مشمع متين
56 fish dock	رصيف الأسماك	18 stern port (stern opening)	فتحة الكوئل	227 Salvage (Salving) and Towage	إِنقَاذ وَقَطْر السُّفُن	5 sou'wester (southwester)	قبعة من المشمع لها حافة خلفية عريضة
57 fish market	سوق الأسماك	19 driven load, a lorry (<i>Am.</i> truck)	بضائع منقولة في شاحنة	1 salvaging (salving) of a ship run aground	بالأرض	6 oilskin jacket	سترة من قماش مشمع متين
58 auction room	صالة المزاد	20 ro-ro depot	مخزن تفريغ وشحن	2 ship run aground (damaged vessel)	سفينة ارتطمت بالأرض (جانحة)	7 oilskin coat	معطف من قماش مشمع متين
59 fish-canning factory	مصنع تعليب الأسماك	21 unitized load (unitized package)	مخزن تحميل ومجموعة	3 sandbank; also: quicksand	ركام رملي- أيضاً رمل سريع الانهيار		
60 push tow	قطر دفعي	22 banana-handling terminal [section]	منصة مناولة الموز [قطاع]	4 open sea	بحر مفتوح	8 inflatable life jacket	سترة نجاة نفاخية
61 tank farm	مركز تجميع الخزانات	23 seaward tumbler	برميل دوار تجاه البحر	5 tug (salvage tug)	سفينة القطر	9 cork life jacket (cork life preserver)	سترة نجاة فليبية
62 railway siding	خط سكة حديدية جانبي	24 jib	ذراع المرفأع	6-15 towing gear	معدات القطر	10 stranded ship (damaged vessel)	سفينة جانحة
63 landing pontoon (landing stage)	رصيف النزول إلى البر	25 elevator bridge	جسر المرفأع	6 towing gear for towing at sea	معدات القطر في البحر	11 oil bag, for trickling oil on the water surface	كيس زيت لتفريط زيت فوق سطح الماء
64 quay	رصيف العمياء	26 chain sling	معلق سلسة (سلسلة تعليق)	7 towing winch (towing machine, towing engine)	ونش القطر	12 lifeline	خبل الإنقاذ
65 breakwater (mole)	مطعم, حاجز أمواج	27 lighting station	منصة إنارة	8 tow rope (tow line, towing hawser)	خبل القطر	13 breeches buoy	طافية, عوامة
66 pier (jetty), a quay extension	رصيف ممتد داخل البحر	28 shore-side tumbler for loading trains and lorries (<i>Am.</i> trucks)	برميل دوار تجاه الساحل لتحميل القطارات والشاحنات	9 tow rope guide	دليل خبل القطر	14 rescue cruiser	طراد الإنقاذ
67 bulk carrier	حاملة شحنات ضخمة	29 bulk cargo handling	مناولة البضائع السائبة/ الضخمة	10 cross-shaped bollard	عمود ربط جبال متصالب	15 helicopter landing deck	سطح هبوط الهليكوبتر
68 silo	صومعة	30 bulk carrier	حاملة البضائع السائبة/ الضخمة	11 hawse hole	فتحة القاس في مقدم السفينة	16 rescue helicopter	طائرة هليكوبتر للملايات الإنقاذ
69 silo cylinder	أسطوانة الصومعة	31 floating bulk-cargo elevator	مرفأع عائم للبضائع السائبة/ الضخمة	12 anchor cable (chain cable)	كبل مرسة	17 daughter boat	قارب الطراد
70 lift bridge	جسر رفعي	32 suction pipes	مرفأع عائم للبضائع السائبة/ الضخمة	13 towing gear for work in harbours (<i>Am.</i> harbors)	معدات القطر للعمل في المرفأ	18 inflatable boat (inflatable dinghy)	قارب نفاخي
71 industrial plant	وحدة صناعية	33 receiver	أنايب ماصة	14 guest rope	خبل نزول	19 life raft	طوف النجاة
72 storage tanks	صهاريج تخزين	34 delivery pipe	وحدة الاستقبال	15 position of the tow rope (tow line, towing hawser)	موضع خبل القطر	20 fire-fighting equipment for fires at sea	معدات مكافحة الحريق في حرائق البحر
73 tanker	ناقلة نفط	35 bulk transporter barge	أنبوب التوصيل	16 tug (salvage tug) [vertical elevation]	مرفأع خبل القطر [مسطح رأسي]	21 hospital unit with operating cabin and exposure bath	وحدة مستشفى للطوارئ بها غرفة عمليات
		36 floating pile driver	صندل نقل البضائع السائبة	17 bow fender (pudding fender)	مصد الجؤجؤ	22 navigating bridge	جسر الملاحة
226 Docks, Port, Harbour (<i>Am.</i> Harbor) (II)	أحواض السفن والعمياء والمرفأ (2)	37 pile driver frame	ميدق خواريزق عائم	18 forepeak	مخزن الجؤجؤ	23 upper tier of navigating bridge	الطاقب العلوي لجسر الملاحة
1 container terminal (container berth), a modern cargo-handling berth	رصيف الحاويات	38 pile hammer	إطار مبدق الخواريزق	19 living quarters	مخزن الجؤجؤ	24 lower tier of navigating bridge	الطاقب السفلي لجسر الملاحة
2 transporter container-loading bridge (loading bridge); <i>sim.</i>	جسر نقال لتحميل الحاويات	39 driving guide rail	مطرقة دق الخواريزق	20 Schottel propeller	وحدات معيشة	25 messroom	ميسي, غرفة الطعام
3 transtainer crane (transtainer)	جسر نقال لتحميل الحاويات	40 pile	قفص دق داليلي	21 Kort vent	رفأص "شوتل"	26 rudders and propeller (screw)	الدفة والرفأص
4 container	حاوية	41 bucket dredger, a dredger	خارزوق	22 engine and propeller room	منفص "كورت"	27 stowage	مخزن
5 all-container ship	عربة شحن	42 bucket chain	كراكة قادوسية/رلوية	23 clutch coupling	غرفة المحرك والرفأص	28 foam can	علبة الرغوة
6 containers stowed on deck	سفينة الحاويات	43 bucket ladder	قطار القواديس	24 compass platform (compass bridge, compass flat, monkey bridge)	مخزن الجؤجؤ	29 side engines	مضركات جانبية
7 truck-to-truck handling (horizontal cargo handling with pallets)	حاويات متراصة على السطح	44 dredger bucket	سلم القواديس	25 fire-fighting equipment	مخزن الجؤجؤ	30 shower	دش
8 forklift truck, forklift	مناولة من شاحنة إلى شاحنة	45 chute	مجري مانل	26 stowage	مخزن الجؤجؤ	31 coxswain's cabin	كابينة موجه الدفة
9 unitized foil-wrapped load (unit load)	شاحنة ذات رافعة شوكية	46 hopper barge	صندل قادوسي	27 tow hook	مخزن الجؤجؤ	32 crew member's single-berth cabin	كابينة بسرير مفرد لأحد أفراد الطاقم
10 flat pallet, a standard pallet	وحدة أحمال مغلقة ومجموعة	47 spoil	تفافية الحفر	28 afterpeak	مخزن الجؤجؤ	33 bow propeller	رفأص الجؤجؤ
11 unitized break-bulk	منصة نقالة مسطحة	48 floating crane	مرفأع عائم	29 stern fender	مخزن الجؤجؤ		
	شحنة عامة مجمعة موحدة	49 jib (boom)	ذراع المرفأع				
		50 counterweight (counterpoise)	ثقل موازن				
		51 adjusting spindle	محور دوران انضباطي				
		52 crane driver's cabin (crane driver's cage)	كابينة سائق المرفأع				

2 span (wing span)	مسافة امتداد الجناحين
3 shoulder-wing monoplane (shoulder-wing plane)	طائرة أحادية السطح كعقبة الجناحين
4 midwing monoplane (midwing plane)	طائرة أحادية السطح متوسطة الجناحين
5 low-wing monoplane (low-wing plane)	طائرة أحادية السطح منخفضة الجناحين
6 triplane	طائرة ثلاثية الأسطح العلوي
7 upper wing	الجناح العلوي
8 middle wing (central wing)	الجناح المتوسط/المركزي
9 lower wing	الجناح السفلي
10 biplane	طائرة ثنائية الأسطح
11 strut	شكال انضغاطي
12 cross bracing wires	أسلاك كتيف متصالية
13 sesquiplane	طائرة أحادية نصفية
14 low-wing monoplane (low-wing plane) with cranked wings (inverted gull wings)	طائرة أحادية السطح منخفضة الجناحين ذات جناحين بمرفقين
15-22 wing shapes	أشكال الجناح
15 elliptical wing	جناح اهليلجي
16 rectangular wing	جناح مستطيل
17 tapered wing	جناح مستدق الطرف
18 crescent wing	جناح هلالى
19 delta wing	جناح مثلثى (دلتا)
20 swept-back wing with semi-positive sweep-back	جناح بزواوية امتداد تراجعى شبه موجب
21 swept-back wing with positive sweepback	جناح بزواوية امتداد تراجعى موجب
22 ogival wing (ogee wing)	جناح بضلع قوسي منحرف
23-36 tail shapes (tail unit shapes, empennage shapes)	أشكال الذيل (أشكال وحدات الذيل)
23 normal tail (normal tail unit)	ذيل عادي
24 & 25 vertical tail (vertical stabilizer and rudder)	ذيل رأسي
24 vertical stabilizer (vertical fin, tail fin)	زعنقة موازنة رأسيّة
25 rudder	دفة الطائرة
26 & 27 horizontal tail	الذيل الأفقي
26 tailplane (horizontal stabilizer)	زعنقة موازنة أفقية
27 elevator	سطح رافع، سكان الارتفاع
28 cruciform tail (cruciform tail unit)	ذيل صليبي الشكل
29 T-tail (T-tail unit)	ذيل تائي الشكل
30 lobe	نقوة مستدير
31 V-tail (vee-tail, butterfly tail)	ذيل فراشة (على شكل حرف V)
32 double tail unit (twin tail unit)	وحدة ذيل مزدوج
33 end plate	لوحة طرفية
34 double tail unit (twin	وحدة ذيل مزدوج لطائرة

tail unit) of a twin-boom aircraft	ذات راقدتين
35 raised horizontal tail with double booms	وحدة ذيل أفقي مرفوع ذو راقدتين
36 triple tail unit	وحدة ذيل ثلاثي
37 system of flaps	نظام الغلايات
38 extensible slat	شريحة/بذة قابلة للامتداد
39 spoiler	جهاز تعطيل (أو تخفيف) الرفع
40 double-slotted Fowler flap	قلاب فاوولر ذو شقيبتين
41 outer aileron (low-speed aileron)	جناح خارجي
42 inner spoiler (landing flap, lift dump)	جهاز تعطيل (أو تخفيف) الرفع الداخلي
43 inner aileron (all-speed aileron)	جناح داخلي
44 brake flap (air brake)	قلابة الكبح
45 basic profile	منظر جانبي أساسي
46-48 plain flaps (simple flaps)	قلابات بسيطة/ مستوية
46 normal flap	قلابة عادية
47 slotted flap	قلابة مشقوبة
48 double-slotted flap	قلابة ذات شقيبتين
49 & 50 split flaps	قلابتان مجزأتان
49 plain split flap (simple split flap)	قلابة مجزأة مستوية
50 zap flap	قلابة "زاب"
51 extending flap	قلابة امتدادية
52 Fowler flap	قلابة "فاوولر"
53 slat	شريحة، بقية، رقيقة
54 profiled leading-edge flap (droop flap)	قلابة متدلّية
55 Krüger flap	قلابة "كروجر"
230 Aircraft II	الطائرة (2)
1-31 cockpit of a single-engine (single-engine) racing and passenger aircraft (racing and passenger plane)	كابينية الطاقم لطائرة أحادية المحرك لنقل الركاب والمسابقات
1 instrument panel	لوحة أجهزة القياس
2 air-speed (Am. air-speed) indicator	مبين سرعة الهواء
3 artificial horizon (gyro horizon)	مبين الأفق الاصطناعي
4 altimeter	مقياس الارتفاع، التيمتر
5 radio compass (automatic direction finder)	بوصلة لاسلكية (محدد اتجاه أوتوماتي)
6 magnetic compass	بوصلة مغناطيسية
7 boost gauge (Am. gage)	مقياس الضغط المعزز
8 tachometer (rev counter, revolution counter)	تاكومتر (عداد الدورات)
9 cylinder temperature gauge (Am. gage)	مقياس حرارة الأسطوانة
10 accelerometer	مقياس التسارع
11 chronometer	كرونومتر، ساعة محكمة الضبط

12 turn indicator with ball	مبين الانعطاف
13 directional gyro	حافظ الاتجاه
14 vertical speed indicator (rate-of-climb indicator, variometer)	مبين السرعة الرأسية
15 VOR radio direction finder [VOR: very high frequency omni-directional range]	محدد اتجاه لاسلكي ذو تردد عال جدا لجميع الاتجاهات
16 left tank fuel gauge (Am. gage)	مبين خزّان الوقود الأيسر
17 right tank fuel gauge (Am. gage)	مبين خزّان الوقود الأيمن
18 ammeter	أميتر
19 fuel pressure gauge (Am. gage)	مقياس ضغط الوقود
20 oil pressure gauge (Am. gage)	مقياس ضغط الزيت
21 oil temperature gauge (Am. gage)	مبين حرارة الزيت
22 radio and radio navigation equipment	معدات الالاسلكي والملاحة الالاسلكية
23 map light	ضوء إضاءة الخريطة
24 wheel (control column, control stick) for operating the ailerons and elevators	عصا التحكم لتشغيل الجناحات والأسطح الرافعة
25 co-pilot's wheel	عصا الطيار المساعد
26 switches	مفاتيح تشغيل
27 rudder pedals	دواسة الدفة
28 co-pilot's rudder pedals	دواسة دفة الطيار المساعد
29 microphone for the radio	ميكروفون الالاسلكي
30 throttle lever (throttle control)	ذراع الصمام الخابق
31 mixture control	مختقة تغيير المزيج
32-66 single-engine (single-engine) racing and passenger aircraft (racing and passenger plane)	طائرة أحادية المحرك لنقل الركاب والمسابقات
32 propeller (airscrew)	مروحة
33 spinner	غطاء قب العروحة
34 flat four engine	محرك رباعي مستو
35 cockpit	كابينية طاقم الطائرة
36 pilot's seat	مقعد الطيار
37 co-pilot's seat	مقعد الطيار المساعد
38 passenger seats	مقاعد الركاب
39 hood (canopy, cockpit hood, cockpit canopy)	غطاء كابينية الطيار
40 steerable nose wheel	عجلة المقدمة القابلة للتوجيه
41 main undercarriage unit (main landing gear unit)	وحدة عجلات الهبوط الرئيسية
42 step	درجة سلمية
43 wing	جناح
44 right navigation light (right position light)	ضوء الملاحة الأيمن
45 spar	عُضد الجناح

46 rib	ضلع الجناح
47 stringer (longitudinal reinforcing member)	رافدة (عضو تقوية طولي)
48 fuel tank	خزان الوقود
49 landing light	أضواء الهبوط
50 left navigation light (left position light)	ضوء الملاحة الأيسر
51 electrostatic conductor	مُوصِل الكترولستاتي
52 aileron	جناح
53 landing flap	قلابة الهبوط
54 fuselage (body)	جسم الطائرة
55 frame (former)	هيكل الطائرة
56 chord	وتر
57 stringer (longitudinal reinforcing member)	رافدة (عضو تقوية طولي)
58 vertical tail (vertical stabilizer and rudder)	ذيل رأسي (زعنقة موازنة رأسيّة ودفة)
59 vertical stabilizer (vertical fin, tail fin)	زعنقة موازنة رأسيّة (زعنقة الذيل)
60 rudder	دفة الطائرة
61 horizontal tail	ذيل أفقي
62 tailplane (horizontal stabilizer)	لوحة الذيل (زعنقة موازنة أفقية)
63 elevator	سطح رافع
64 warning light	أضواء تحذيرية (أضواء لتفادي الاصطدام)
65 dipole antenna	هوائي ثنائي القطب
66 long-wire antenna (long-conductor antenna)	هوائي سلك توصيل طويل
67-72 principal manoeuvres (Am. maneuvers) of the aircraft (acroplane, plane, Am. airplane)	حركات المناورة الأساسية للطائرة
67 pitching	ترجج
68 lateral axis	المحور الجانبي
69 yawing	انجراف
70 vertical axis (normal axis)	المحور الرأسي
71 rolling	عطوف
72 longitudinal axis	المحور الطولي
231 Aircraft III	الطائرة (3)
1-33 types of aircraft (acroplanes, planes, Am. airplanes)	أنواع الطائرات
1-6 propeller-driven aircraft (acroplanes, planes, Am. airplanes)	طائرة بمروحة
1 single-engine (single-engine) racing and passenger aircraft (racing and passenger plane), a low-wing monoplane (low-wing plane)	طائرة بمحرك واحد لنقل الركاب والمسابقات، طائرة منخفضة الجناحين
2 single-engine (single-engine) passenger aircraft, a high-wing	طائرة بمحرك واحد لنقل الركاب، طائرة أحادية السطح مرتفعة الجناحين

monoplane (high-wing plane)	طائرة بمحركين للنقل الركاب والأعمال
3 twin-engine (twin-engine) business and passenger aircraft (business and passenger plane)	طائرة ركاب ضخمة للمسافات القصيرة والمتوسطة
4 short/modium haul airliner, a turboprop plane (turbopropeller plane, propeller-turbine plane)	محرك دفع توربيني
5 turboprop engine (turbopropeller engine)	وحدة مؤازرة رأسية (زعنفة رأسية، زعنفة الذيل)
6 vertical stabilizer (vertical fin, tail fin)	الطائرات النفاثة
7-33 jet planes (jet aeroplanes, jets, Am. jet airplanes)	طائرة بمحركين لنقل الركاب والأعمال
7 twin-jet business and passenger aircraft (business and passenger aircraft (business and passenger plane)	حظائر
8 fence	خزان وقود بطرف الجناح
9 wing-tip tank (tip tank)	محرك خلفي
10 rear engine	طائرة ركاب ضخمة بمحركين نفاثين للمسافات القصيرة والمتوسطة
11 twin-jet short/medium haul airliner	طائرة ركاب ضخمة بثلاثة محركات نفاثة للمسافات المتوسطة
12 tri-jet medium haul airliner	طائرة ركاب ضخمة بأربعة محركات نفاثة للمسافات الطويلة
13 four-jet long haul airliner	طائرة ركاب جامبو
14 wide-body long haul airliner (jumbo jet)	طائرة ركاب ضخمة أسرع من الصوت [كوكورد]
15 supersonic airliner [Concorde]	مقدمة مدلاة
16 droop nose	طائرة ركاب ضخمة متسعة ذات محركين نفاثين للمسافات القصيرة والمتوسطة (طائرة إيرباص)
17 twin-jet wide-body airliner for short/medium haul routes (airbus)	مقدمة رادارية مع هوائي رادار (رصد) جوي
18 radar nose (radome, radar dome) with weather radar antenna	كابينة طاقم الطائرة
19 cockpit	مطبخ الطائرة
20 galley	خجيرة البضائع
21 cargo hold (hold, underfloor hold)	كابينة الركاب وبها المقاعد
22 passenger cabin with passenger seats	وحدة عجلات الهبوط
23 retractable nose undercarriage unit (retractable nose	الأمامية القابلة للضم

landing gear unit)	غطاء حجيبة عجلات الهبوط
24 nose undercarriage flap (nose gear flap)	الأمامية
25 centre (Am. center) passenger door	باب الركاب الأوسط
26 engine pod with engine (turbojet engine, jet turbine engine, jet turbine)	طرف المحرك وبدخله المحرك التوربيني النفاث
27 electrostatic conductors	موصلات الكترولستاتيكية
28 retractable main undercarriage unit (retractable main landing gear unit)	وحدة عجلات الهبوط الرئيسية القابلة للضم
29 side window	نافذة جانبية
30 rear passenger door	باب الركاب الخلفي
31 toilet (lavatory, WC)	نورة مياه
32 pressure bulkhead	حاجز إنشائي فاصل ضغطي
33 auxiliary engine (auxiliary gas turbine) for the generator unit	محرك إضافي/مساعد لوحدة المولد

232 Aircraft IV	الطائرة (4)
1 flying boat, a seaplane	طائرة مائية
2 hull	مقدم الطائرة
3 stub wing (sea wing)	جناح أثير
4 tail bracing wires	أسلاك تقوية الذيل
5 floatplane (float seaplane), a seaplane	طائرة بوعامة، طائرة بحرية
6 float	وعامة
7 vertical stabilizer (vertical fin, tail fin)	زعنفة مؤازرة رأسية
8 amphibian (amphibian flying boat)	طائرة برمائية
9 hull	مقدم الطائرة
10 retractable undercarriage (retractable landing gear)	عجلات الهبوط القابلة للضم
11-25 helicopters	طائرات هليكوبتر، الطائرات العمودية هليكوبتر خفيفة متعددة الأدوار
11 light multirole helicopter	مروحة رئيسية
12, 13 main rotor	جناح المروحة
12 rotary wing (rotor blade)	رأس المروحة
13 rotor head	دوار الدفع الرافع الخلفي
14 tail rotor (anti-torque rotor)	محافظا الهبوط
15 landing skids	مرافق طائر
16 flying crane	مركبات توربينية
17 turbine engines	هيكل سفلي للرفع
18 lifting undercarriage	منصة الرفع
19 lifting platform	خزان الوقود الاحتياطي هليكوبتر للنقل
20 reserve tank	مروحتان توافقيتان
21 transport helicopter	عمود المروحة
22 rotors in tandem	محرك توربيني
23 rotor pylon	
24 turbine engine	

25 tail loading gate	باب الشحن الخلفي
26-32 V/STOL aircraft (vertical/short take-off and landing aircraft)	طائرة عمودية للإقلاع القصير والهبوط
26 tilt-wing aircraft, a VTOL aircraft (vertical take-off and landing aircraft)	طائرة بجناح مائل (طائرة إقلاع وهبوط عمودي)
27 tilt wing in vertical position	جناح مائل في وضع رأسي
28 contrarotating tail propellers	ميسرات ذيل تدور في اتجاه معاكس
29 gyrodyne	جيروداين، جيروسكوب
30 turboprop engine (turbopropeller engine)	محرك ذو رفاص توربيني
31 convertiplane	طائرة عمودية أفقية
32 tilting rotor in vertical position	مروحة مائلة في وضع رأسي
33-60 aircraft engines (aero engines)	محرركات الطائرة
33-50 jet engines (turbojet engines, jet turbine engines, jet turbines)	المحركات النفاثة
33 front fan-jet	منفذ المروحة الأمامية
34 fan	مروحة
35 low-pressure compressor	ضاغط ضغط منخفض
36 high-pressure compressor	ضاغط ضغط مرتفع
37 combustion chamber	حجرة الاحتراق
38 fan-jet turbine	توربين منفث المروحة
39 nozzle (propelling nozzle, propulsion nozzle)	فوهة (فوهة الدفع)
40 turbines	توربينات
41 bypass duct	مجري جانبي/ثانوي
42 aft fan-jet	منفذ المروحة الخلفي
43 fan	مروحة
44 bypass duct	مجري جانبي/ثانوي
45 nozzle (propelling nozzle, propulsion nozzle)	فوهة الدفع
46 bypass engine	محرك مساعد
47 turbines	توربينات
48 mixer	خلاط
49 nozzle (propelling nozzle, propulsion nozzle)	فوهة (فوهة الدفع)
50 secondary air flow (bypass air flow)	دفع هواء ثانوي
51 turboprop engine (turbopropeller engine), a twin-shaft engine	محرك دفع توربيني
52 annular air intake	مدخل هواء حلقي
53 high-pressure turbine	توربين ضغط عال
54 low-pressure turbine	توربين ضغط منخفض
55 nozzle (propelling nozzle, propulsion nozzle)	فوهة (فوهة الدفع)

56 shaft	عمود
57 intermediate shaft	عمود وسطي
58 gear shaft	عمود المشنقات
59 reduction gear	ترس تخفيض السرعة
60 propeller shaft	عمود (دوران) المروحة

233 Airport	المطار
1 runway	مدراج إقلاع وهبوط
2 taxiway	الطائرات
3 apron	مدراج جانبي
4 apron taxiway	خطيرة الطائرات
5 baggage terminal	مدراج حظيرة الطائرات
6 tunnel entrance to the baggage terminal	منطقة العفش
7 airport fire service	مدخل نفقي يؤدي إلى محطة البضائع
8 fire appliance building	مركز إطفاء المطار
9 mail and cargo terminal	منتهي معدات الإطفاء
10 cargo warehouse	محطة البريد والبضائع
11 assembly point	مستودع البضائع
12 pier	نقطة التجمع
13 pierhead	رصيف
14 airbridge	رأس الرصيف
15 departure building (terminal)	جسر جوي
16 administration building	صالة/ منتهي المغادرة
17 control tower (tower)	منتهي الإدارة
18 waiting room (lounge)	برج المراقبة
19 airport restaurant	صالة الانتظار
20 spectators' terrace	منطع المطار
21 aircraft in loading position (nosed in)	شرفة الزوار/المودعين
22 service vehicles, e.g. baggage loaders, water tankers, galley loaders, toilet-cleaning vehicles, ground power units, tankers	طائرة في وضع التحميل
23 aircraft tractor (aircraft tug)	عربات الخدمة، ومنها لوابر العفش وصهاريج الماء والوابر الأطلعة إلى المطبخ وعربات تنظيف دورات المياه ووحدات الطاقة الأرضية والخزانات
24-53 airport information symbols (pictographs)	جزر الطائرة

رموز المعلومات بالمطار	
24 'airport'	"مطار"
25 'departures'	"المغادرون"
26 'arrivals'	"القادمون"
27 'transit passengers'	"ركاب الترانزيت"
28 'waiting room' ('lounge')	"صالة الانتظار"
29 'assembly point' ('meeting point', 'rendezvous point')	"نقطة التجمع"
30 'spectators' terrace'	"شرفة الزوار/المودعون"
31 'information'	"استعلامات"
32 'taxi'	"سيارات أجرة"
33 'car hire'	"تأجير سيارات"
34 'trains'	"القطارات"
35 'buses'	"الحافلات"
36 'entrance'	"دخول"

37 'exit'	"خروج"	oxygen	ألية توصيل بين الخزانات	46 work platform (working platform)	منصة شغل	11 integrally stiffened light alloy skin	بشرة من سبيكة خفيفة مقواة
38 'baggage reclaim'	"استرجاع الأمتعة"	16 inter-tank connector (inter-tank section)	ألية توصيل بين الخزانات	47 cable duct	مجرى الكيبلات	12 lattice girder	عارضة شبكية
39 'luggage lockers'	"دواليب الأمتعة"	17 instruments and system-monitoring devices	الألات وأجهزة مراقبة الأنظمة	48 acceleration rockets for fuel acquisition	صواريخ التسارع للحصول على الوقود	13 payload bay insulation	عازل فُرجة الحمل الأجر
40 'telephone - emergency calls only'	"هاتف - للطوارئ فقط"	18 second rocket stage (S-II)	منصة الصاروخ الثاني (S-II)	49 aft frame section	جزء الهيكل الخلفي	14 payload bay door	باب فُرجة الحمل الأجر
41 'emergency exit'	"مخرج طوارئ"	19 J-2 engines	محركات J-2	50 compressed-helium tanks (helium pressure vessels)	خزانات الهيليوم المضغوط	15 low-temperature surface insulation	عازل سطح منخفض الحرارة
42 'passport check'	"التجوّزات"	20 heat shield (thermal protection shield)	درع واق من الحرارة	51 liquid hydrogen (LH ₂) line	خط الهيدروجين السائل	16 flight deck (crew compartment)	سطح الطيران (حجينة الطاقم)
43 'press facilities'	"تسهيلات صحافية"	21 engine mounts and thrust structure	مخاميل المحركات وهيكल الدفع	52 liquid oxygen (LOX, LO ₂) line	خط الأكسجين السائل	17 captain's seat (commander's seat)	مقعد كابتن الطاقم
44 'doctor'	"طبيب"	22 acceleration rockets for fuel acquisition	صواريخ التسارع للحصول على الوقود	53 24-panel instrument unit	وحدة آلات بها 24 لوحة	18 pilot's seat (co-pilot's seat)	مقعد الطيار (مقعد مساعد الطيار)
45 'chemist' (Am. 'druggist')	"صيدلية"	23 liquid hydrogen (LH ₂) suction line	خط شفط الهيدروجين السائل	54 LM hangar (lunar module hangar)	عتبر الموديويلات القمرية	19 forward pressure bulk-head	حاجز إشتائي أمامي مضطفي
46 'showers'	"أدشاش استحمام"	24 liquid oxygen (LOX, LO ₂) tank [capacity: 1,315,000 litres]	خزان الأكسجين السائل [سعة مليون و315 ألف لتر]	55 LM (lunar module)	موديول قمرى	20 carbon fibre reinforced nose cone	جزء المقدمة المقوى بألياف كربونية
47 'gentlemen's toilet' ('gentlemen')	"دورة مياه للرجال"	25 standpipe	أنبوب قائم	56 Apollo SM (service module), containing supplies and equipment	موديول الخدمة أبولو وبه المؤن والمعدات	21 forward fuel tanks	خزانات الوقود الأمامية
48 'ladies toilet' ('ladies')	"دورة مياه للسيدات"	26 liquid hydrogen (LH ₂) tank [capacity: 1,020,000 litres]	خزان الهيدروجين السائل [سعة مليون وعشرين ألف لتر]	57 SM (service module) main engine	المحرك الرئيسي لموديول الخدمة	22 avionics consoles	كونسولات آلات الطيران
49 'chapel'	"كنيسة صغيرة"	27 fuel level sensor	مكتشاف مستوى الوقود	58 fuel tank	خزان الوقود	23 automatic flight control panel	لوحة التحكم في الطيران الألى
50 'restaurant'	"مطعم"	28 work platform (working platform)	منصة شغل	59 nitrogen tetroxide tank	خزان رابع أكسيد النيتروجين	24 upward observation windows	نوافذ ملاحظة علوية
51 'change'	"تساقف"	29 cable duct	مجرى الكيبلات	60 pressurized gas delivery system	نظام توصيل الغاز المضغوط	25 forward observation windows	نوافذ ملاحظة أمامية
52 'duty free shop'	"السوق الحرة"	30 manhole	فتحة	61 oxygen tanks	خزانات الأكسجين	26 entry hatch to payload bay	كوة دخول فُرجة الحمل الأجر
53 'hairstresser'	"مصفف شعر"	31 S-IC/S-II inter-stage connector (inter-stage section)	ألية توصيل بين منصتي الصاروخين الأول والثاني	62 fuel cells	خلايا وقودية	27 air lock	ديسام هوائي
		32 compressed-gas container (gas pressure vessel)	حاوية الغاز المضغوط	63 manoeuvring (Am. maneuvering) rocket assembly	مجموعة صواريخ المناورة	28 ladder to lower deck	سلم يؤدي إلى السطح السفلى
		33 third rocket stage (S-IVB)	منصة الصاروخ الثالث	64 directional antenna assembly	مجموعة هوائي اتجاهاي	29 payload manipulator arm	ذراع آلية معالجة الحمل الأجر
		34 J-2 engine	محرك J-2	65 space capsule (command section)	كبسولة فضائية (جزء القيادة)	30 hydraulically steerable nose wheel	عجلة مقدمة يتم توجيهها هيدرولياً
		35 nozzle (thrust nozzle)	فوهة (فوهة الدفع)	66 launch phase escape tower	برج انفلات مرحلة الإطلاق	31 hydraulically operated main landing gear	عجلة الهبوط الرئيسية التي يتم تشغيلها هيدرولياً
		36 S-II/S-IVB inter-stage connector (inter-stage section)	ألية توصيل بين منصتي الصاروخين الثاني والثالث			32 removable (reusable) carbon fibre reinforced leading edge (of wing)	حافة أمامية مقواة مصنوعة من الفبر قابلة للفصل
		37 four second-stage (S-II) separation retro-rockets	أربعة صواريخ كايحة للفصل في المنصة الثانية			33 movable elevision sections	أجزاء سطح رافع عاطف قابلة للفصل
		38 attitude control rockets	صواريخ ضبط الوجهة	235 Space Flight II	الطيران في الفضاء (2)	34 heat-resistant elevision structure	هيكل سطح رافع عاطف مقاوم للحرارة
		39 liquid oxygen (LOX, LO ₂) tank [capacity: 77,200 litres]	خزان الأكسجين السائل [سعة 77 ألف و200 لتر]	1-45 Space Shuttle-Orbiter	غربة فضائية مدارية موكبية	35 main liquid hydrogen (LH ₂) supply	مصدر إمداد الهيدروجين السائل الرئيسي
		40 fuel line duct	مجرى خط الوقود	1 twin-spar (two-spar, double-spar) vertical fin	رغيفة رأسية ذات ضندين	36 main liquid-fuelled rocket engine	محرك صاروخي رئيسي يعمل بالوقود السائل
		41 liquid hydrogen (LH ₂) tank [capacity: 253,000 litres]	خزان الهيدروجين السائل [سعة 253 ألف لتر]	2 engine compartment structure	هيكل حجينة المحرك	37 nozzle (thrust nozzle)	فوهة (فوهة الدفع)
		42 measuring probes	مستبارات قياس	3 fin post	قضيب الزعفة	38 coolant feed line	خط تغذية المبرد
		43 compressed-helium tanks (helium pressure vessels)	خزانات الهيليوم المضغوط	4 fuselage attachment [of payload bay doors]	مُلحِق جسم الغربة [لأبواب فرجة الحمل الأجر]	39 engine control system	نظام التحكم في المحرك
		44 tank vent	فتحة تهوية الخزان	5 upper thrust mount	محمل الدفع العلوي	40 heat shield	وقاء الحرارة
		45 forward frame section	جزء الهيكل الأمامي	6 lower thrust mount	محمل الدفع السفلي	41 high-pressure liquid hydrogen (LH ₂) pump	مضخة هيدروجين سائل عالية الضغط
				7 keel	صايلب القاعدة، أريئة	42 high-pressure liquid oxygen (LOX, LO ₂) pump	مضخة أكسجين سائل عالية الضغط
				8 heat shield	درع واق من الحرارة	43 thrust vector control system	نظام التحكم في كمية الدفع الموجهة
				9 waist longeron	الضلع الطولاني الأوسط	44 electromechanically	محرك متأورة مدارية
				10 integrally machined (integrally milled) main rib	ضلع رئيسي مصنع ألياً		

36 pre-distributor channel	قناة التوزيع الأولي	11 keypad with number and function keys (feature keys)	لوحة مفاتيح الأرقام والوظائف
37 process control computer	كمبيوتر تحكم	12 last number redial button	زر تكرار آخر رقم
38 distributing machine	ماكينة توزيع	13 abbreviated dialling key	زر اتصال مختزل
39 video coding station	محطة وضع الرموز البريدية المرئية	14 speaker key (loud-speaker key)	زر ميكرو الصوت
40 screen	شاشة	15 mouthpiece	صوان التكلم في الهاتف
41 address display	عرض العنوان	16 line reset button	زر إعادة ضبط الخط
42 address	عنوان	17 speaker (loudspeaker)	ميكرو صوت (ساعة صوت)
43 post code (postal code, Am. zip code)	رمز بريدي	18 call indicator	مؤشر الاتصال
44 keyboard	لوحة المفاتيح	19 push-button telephone, an added-feature telephone	هاتف بأزرار انضغاطية
45 handstamp	ختامة يدوية	20 display	شاشة
46 roller stamp	ختامة أسطوانية	21 lock	قفل
47 franking machine	ماكينة دمج الرسائل	22 novelty telephone, an added-feature telephone	هاتف ديكور كلاسيكي
48 feed mechanism	آلية الإلقام	23 (telephone) cradle	محمل الساعة
49 delivery mechanism	آلية التوصيل	24 dummy crank	ذراع تدوير دمية
50-55 postal collection and delivery	تجميع البريد وتسليمه	25 detachable keypad	لوحة مفاتيح قابلة للفصل
50 postbox (Am. mailbox)	صندوق بريد	26 cordless (telephone) (radiophone, mobile phone)	هاتف لاسلكي
51 collection bag	حقبية جمع البريد	27 aerial	هوائي
52 post office van (mail van)	عربة مكتب البريد	28 battery strength light	ضوء إرشادي لقوة البطارية
53 postman (Am. mail carrier, letter carrier, mailman)	رجل البريد	29 out of signal-range indicator	مؤشر أن الهاتف خارج نطاق الخدمة
54 delivery pouch (postman's bag, mailbag)	حقبية توزيع البريد	30 power switch	مفتاح التشغيل/الإيقاف
55 letter-rate item	بند فئة الرسالة	31 cardphone	هاتف يعمل بنظام البطاقات
56-60 postmarks	أختام البريد	32 split display showing call charges	شاشة منفصلة توضح رسوم المكالمات
56 postmark advertisement	ختم بريد إعلاني	33 language select button for the display	زر اختيار لغة الشاشة
57 date stamp postmark	ختم التاريخ	34 follow-on call button	زر مواصلة الاتصال
58 charge postmark	ختم الرسوم البريدية	35 phonecard slot	فتحة إدخال بطاقة الاتصال
59 special postmark	ختم بريد خاص	36 phonecard (here: telephone credit card)	بطاقة الاتصال بالهاتف (هنا بطاقة ائتمان للاتصالات الهاتفية)
60 roller postmark	علامة بريد موجية	37 phonecard symbol	رمز بطاقة الاتصال بالهاتف
61 stamp (postage stamp)	طابع بريد	38 cardholder's name	اسم حامل البطاقة
62 perforations	ثقوب	39 card number	رقم البطاقة
237 Post Office II (Telecommunications)	مكتب البريد (2) (الاتصالات السلكية واللاسلكية)	40 arrow indicating direction of insertion	سهم يشير إلى اتجاه إدخال البطاقة بالهاتف
1-41 telephone	هاتف ، تليفون	41 chips	رقائق
1 dial telephone	هاتف بقرص	42-62 ISDN (Integrated Services Digital Network)	شبكة رقمية للخدمات المتكاملة
2 handset (telephone receiver)	سماعة الهاتف	42 multifunction telecommunications terminal (ISDN workstation)	طرفية اتصالات متعددة الوظائف
3 receiver cord (handset cord)	سلك السماعة	43 screen (monitor) for viewdata, video telephone, and Teletex	شاشة للبيانات المرئية ، هاتف ناقل للصورة وتلكس
4 telephone cable (telephone cord)	كابل الهاتف ، سلك التليفون	44 central processing and	وحدة المعالجة والذاكرة
5 telephone casing (telephonic cover)	جسم الهاتف ، غلبة التليفون		
6 emergency numbers	أرقام الطوارئ		
7 line number	رقم الخط		
8 dial	قرص الهاتف		
9 compact telephone (slim line telephone), an added-feature telephone	هاتف مندمج		
10 earpiece (receiver)	أذنية (المستقبل)		

controlled orbital manocuvring (Am. maneuvering) main engine	رئيسي يتم التحكم فيه كهروميكانيكياً	236 Post Office I	مكتب البريد (1)
45 nozzle fuel tanks (thrust nozzle fuel tanks)	خزانات الوقود بقوة الدفع	1-30 main hall	الصالة الرئيسية
46 jettisonable liquid hydrogen and liquid oxygen tank (fuel tank)	خزان أكسجين سائل وهيدروجين سائل قابلين للطرح (خزان وقود)	1 parcels counter	شباك الطرود
47 integrally stiffened annular rib (annular frame)	ضلع طرفي مقوى شبه كروي	2 parcels scales	ميزان الطرود
48 hemispherical end rib (end frame)	ضلع طرفي شبه كروي	3 parcel	طرود
49 aft attachment to Orbiter	المحلق الخلفي للعبة المدارية	4 stick-on address label with parcel registration slip	بطاقة عتاقوين لاصقة مع كعب تسجيل الطرد
50 liquid hydrogen (LH ₂) line	خط الهيدروجين السائل	5 glue pot	قنية الصمغ
51 liquid oxygen (LOX, LO ₂) line	خط الأكسجين السائل	6 small parcel	طرود صغير
52 manhole	فتحة	7 franking machine (Am. postage meter) for parcel registration cards	ماكينة دمج بطاقات تسجيل الطرود
53 surgebaffle system (slosh baffle system)	نظام حواجز التمور	8 telephone box (telephone booth, telephone kiosk, call box)	كثك الهاتف
54 pressure line to liquid hydrogen tank	خط ضغط واصل لخزان الهيدروجين السائل	9 coin-box telephone (pay phone, public telephone)	هاتف يعمل بالعملة المعدنية
55 electrical system bus	اوتوبوس النظام الكهربائي	10 telephone directory rack	رف دليل الهاتف
56 liquid oxygen (LOX, LO ₂) line	خط الأكسجين السائل	11 directory holder	حامل الدليل
57 pressure line to liquid oxygen tank	خط ضغط واصل لخزان الأكسجين السائل	12 telephone directory (telephone book)	دليل الهاتف
58 recoverable solid-fuel rocket (solid rocket booster)	صاروخ قابل للاسترجاع يعمل بالوقود الصلب	13 post office boxes	صناديق مكتب البريد
59 auxiliary parachute bay	فرجة مظلة مساعدة	14 post office box	صندوق بريد
60 compartment housing the recovery parachutes and the forward separation rocket motors	حجرة مظلات الاسترجاع والمحركات الأمامية لصاروخ الانفصال	15 stamp counter	شباك بيع الطابع
61 cable duct	مجري الكيبلات	16 counter clerk (counter officer)	موظف الشباك
62 aft separation rocket motors	المحركات الخلفية لصاروخ الانفصال	17 company messenger	سامي شركة
63 aft skirt	حاشية/حافة خلفية	18 record of posting book	سجل كتبي الإرسال
64 swivel nozzle (swivelling, Am. swiveling, nozzle)	قوة دورانية	19 counter stamp machine	ماكينة الطابع بالشباك
65 Spacelab (space laboratory, space station)	مختبر فضائي	20 stamp book	ملف حفظ الطابع
66 multi-purpose laboratory (orbital workshop)	مختبر متعدد الأغراض (ورشة مدارية)	21 sheet of stamps	فرج طابع
67 astronaut	رجل فضاء	22 security drawer	درج أمان
68 gimbal-mounted telescope	تليسكوب على حامل ذي محورين	23 change rack	درج الصرف
69 measuring instrument platform	منصة آلات القياس	24 letter scales	ميزان الخطابات
70 spaceflight module	موديول فضائي	25 paying-in (Am. deposit), post office savings, and pensions counter	شباك تسديد الفواتير ودفاتر توفير البريد والمعاشات
71 crew entry tunnel	نفق دخول الطاقم	26 accounting machine	ماكينة حاسبة
		27 franking machine for money orders and paying-in slips (Am. deposit slips)	ماكينة دمج أوامر الدفع وايصالات التسديد
		28 change machine (Am. changemaker)	ماكينة صرافة
		29 receipt stamp	ختامة الايصالات
		30 hatch	فتحة ، كوة
		31-44 letter-sorting installation	قسم فرز الرسائل
		31 letter feed	إلقام الرسائل
		32 stacked letter containers	حاويات رسائل متراصة
		33 feed conveyor	سير الإلقام
		34 intermediate stacker	جهاز ترصيص وسطي
		35 coding station	محطة وضع الرموز البريدية

18 studio	ستوديو	53 talkback microphone	ميكروفون الانترنتون
19 sound engineer (sound control engineer)	مهندس الصوت	54-59 pre-mixing room for transferring and mixing 16 mm, 17.5 mm, 35 mm perforated magnetic film	غرفة المكساج المتقدم لنقل ودبلجة فيلم مغناطيسي مثقب مقاس 16 ملم ، 17.5 ملم ، 35 ملم
20 sound control desk (sound control console)	لوحَة التَحْكُم في الصوت	54 sound control desk (sound control console)	كوسول التَحْكُم في الصوت
21 newsreader (newscaster)	قارئ نشرة الأخبار	55 compact magnetic tape recording and playback equipment	معدّات تسجيل وتشغيل الشرائط المغناطيسية المُتَمَدِّجَة
22 duty presentation officer	موظّف التقديم المناوب	56 single playback deck	جهاز تشغيل مفرد
23 telephone for phoned reports	هاتف لتلقي التقارير الهاتفية	57 central drive unit	وحدة الدفع المركزية
24 record turntable	صينية تشغيل الأسطوانات	58 single recording and playback deck	جهاز تسجيل وتشغيل مفرد
25 recording room mixing console (mixing desk, mixer)	كوسول مكساج غرفة التَحْكُم	59 rewind bench	نضد اعادة لف الفيلم
26 sound technician (sound mixer, sound recordist)	فني الصوت	60-65 final picture quality checking room	غرفة فحص جودة الصورة النهائية
27-53 television post-sync studio	ستوديو البثّ	60 preview monitor	شاشة العرض المُسَبِّق
27 sound production control room (sound control room)	التليفزيوني المعزّامن غرفة التَحْكُم الخاصة بانتاج الصوت	61 programme (Am. program) monitor	شاشة البرامج
28 dubbing studio (dubbing theatre, Am. theater)	ستوديو الدبلجة	62 stopclock	ساعة وقف
29 studio table	طاولة الاستوديو	63 vision mixer (vision-mixing console, vision-mixing desk)	كوسول دمج الصور
30 visual signal	إشارة مرئية	64 talkback system (talk-back equipment)	نظام الانترنتون
31 electronic stopclock	ساعة وقف إلكترونية	65 camera monitor (picture monitor)	شاشة الكاميرا
32 projection screen	شاشة العرض	239 Broadcasting (Radio and Television) II	الإذاعة (الراديو والتليفزيون) (2)
33 monitor	مرقّاب	1-15 outside broadcast (OB) vehicle (television OB van; also: sound OB van, radio OB van)	عربة التسجيلات الخارجية (عربة التليفزيون، عربة الإذاعة)
34 studio microphone	ميكروفون الاستوديو	1-4 rear equipment section of the OB vehicle	معدّات الجزء الخلفي في عربة التسجيلات الخارجية
35 sound effects box	صندوق المؤثرات الصوتية	2 camera cable	كابل الكاميرا
36 microphone socket panel	لوحَة مقابس الميكروفونات	3 cable connection panel	لوحَة توصيل الكيبلات
37 recording speaker (recording loudspeaker)	مكبر صوت خاص بالتسجيل	4 television (TV) reception aerial (receiving aerial) for Channel I	هوائي استقبال بَقْرُنِيَّاتٍ للقناة الأولى
38 control room window (studio window)	نافذة غرفة التَحْكُم	5 television (TV) reception aerial (receiving aerial) for Channel II	هوائي استقبال بَقْرُنِيَّاتٍ للقناة الثانية
39 producer's talkback microphone	انترفون المُنتج	6 interior equipment (on-board equipment) of the OB vehicle	المعدّات الداخلية لعربة التسجيلات الخارجية
40 local-battery telephone	هاتف بطارية محلية	7 sound production control room (sound control room)	غرفة ضبط الصوت
41 sound control desk (sound control console)	كوسول التحكم في الصوت	8 sound control desk (sound control console)	كوسول التَحْكُم في الصوت
42 group selector switch	مفتاح انتقاء التسجيل الجماعي		
43 visual display	عرض بصري		
44 limiter display (clipper display)	شاشة محدد الخرج		
45 control modules	موديولات التَحْكُم		
46 pre-listening buttons	أزرار الاستماع المُسَبِّق		
47 slide control	آلية تحكم انزلاقية		
48 universal equalizer (universal corrector)	مُعَادِل عام		
49 input selector switches	مفاتيح انتقاء الدخّل		
50 pre-listening speaker	مكبر صوت للاستماع المسبق		
51 tone generator	مُولد النغمة		
52 talkback speaker	مكبر صوت الانترنتون		

memory unit	المركَزِيَّة	satellite television, and cable television	تلفزيون الأقمار الصناعية، وتلفزيون الكابيل
45 fax unit (fax)	وحدة الفاكس	80 broadcasting satellite	قَمَر البِثّ
46 input device (keyboard)	لوحَة مفاتيح الإدخال	81 television studio	ستوديو التليفزيون
47 telephone receiver (link to the telephone network)	ساعة الهاتف	82 television tower	بَرْج البثّ المرئيّ
48 acoustic coupler (modem)	مُوَدَم (قارئة صوتيّة)	83 cablehead station	محطة رأس كيبلية
49 telecontrol network (TEMEX network)	شبكة التَحْكُم عن بعد	84 terrestrial broadcasting	البثّ الأرضي
50 public telephone network (switched telephone network)	شبكة الهاتف العمومي	85 satellite broadcasting	البثّ من القمر الصناعي
51 telecontrol centres	مراكز التَحْكُم عن بعد	86 line-of-sight link (microwave link)	وأصلة خط الرؤية
52 TEMEX main control centre	مركز التَحْكُم الرئيسي في شبكة التَحْكُم عن بعد	87 cable network	شبكة الكيبلات
53 TEMEX transmission equipment	معدّات إرسال شبكة التَحْكُم عن بعد	88 cable connections	وصلات الكيبلات
54 telecommunications line (telephone line)	خط اتصالات سلكيّة ولاسلكيّة	238 Broadcasting (Radio and Television) I	الإذاعة (الراديو والتليفزيون) (1)
55 TEMEX network termination	انتهاء شبكة TEMEX	1-6 central recording channel of a radio station	محطة تسجيل مركزي بمحطة الإذاعة
56 slave station	محطة تابعة	1 monitoring and control panel	لوحَة المشاهدة والتَحْكُم
57 telecontrol terminal equipment	معدّات طرفيّة التَحْكُم عن بعد	2 data display terminal (video data terminal, video monitor) for visual display of computer-controlled programmes (Am. programs)	طرفيّة عرض البيانات للعرض المرئي للبرامج التي يجري التَحْكُم فيها بالحاسب الآلي
58 telecontrol terminal equipment (detector, sensor, or control equipment)	معدّات طرفيّة التَحْكُم عن بعد (معدّات كشف أو استشعار أو تحكّم)	3 amplifier and mains power unit	مُضَخّ صوت ووحدة الطاقة الرئيسيّة
59 glass-break detector	مكشّاف الكسر الزجاجي	4 magnetic sound recording and playback deck for 1/4" magnetic tape	جهاز تسجيل الصوت المغناطيسي والاستماع إليه للشرائط المغناطيسية حجم ربع بوصة
60 temperature controller	آلية التَحْكُم في درجة الحرارة	5 magnetic tape, 1/4" tape	شريط مغناطيسي، شريط ربع بوصة
61 emergency call	مكشّاف الكسر الزجاجي	6 film spool holder	حامل بكرّة الفيلم
62 meter (electricity meter)	آلية التَحْكُم في درجة الحرارة	7-15 radio switching centre (Am. center) control room	غرفة التَحْكُم في مركز التحويل الإذاعي
63 communications satellite	مقيّاس الكهرباء	7 monitoring and control panel	لوحَة المشاهدة والتَحْكُم
64 solar panel (solar paddle, solar array, solar generator)	قمر صناعي للاتصالات السلكية واللاسلكية	8 talkback speaker	مكبر صوت الانترنتون
65 antenna module	صنّفحة شمسيّة (أرياش بخلايا شمسيّة)	9 local-battery telephone	هاتف بطارية محلية
66 receiving antenna for control commands	موديول الهوائي	10 talkback microphone	ميكروفون الانترنتون
67 parabolic antennas	هوائي استقبال أوامر التَحْكُم	11 data display terminal (video data terminal)	طرفيّة عرض البيانات
68 communications module	هوائيات مكافئيّة المقطع	12 teleprinter	طابعة عن بعد
69 propulsion module	موديول الاتصالات	13 input keyboard for computer data	لوحَة إدخال بيانات الكمبيوتر
70 broadcasting satellite (television satellite)	موديول التسيير	14 telephone switchboard panel	لوحَة بدالة الهاتف
71 service module	قمر صناعي خاص بالبثّ التليفزيوني	15 monitoring speaker (control speaker)	مكبر صوت للمتابعة والتَحْكُم
72 fuel tanks	موديول خدمة	16-26 broadcasting centre (Am. center)	مركز الإذاعة
73 control jets	خزّانات الوقود	16 recording room	غرفة التسجيل
74 earth station	مناث التَحْكُم	17 production control room (control room)	غرفة مراقبة الإنتاج
75 parabolic antenna	محطة أرضيّة		
76 main reflector	هوائي مكافئي المقطع		
77 feed antenna	عاكس رئيسي		
78 radio beams	هوائي تغذية		
79 satellite broadcasting,	جزم أشعة لاسلكية		
	البثّ عبر الأقمار الصناعية		

9 monitoring loudspeaker	سماعة صوت للمتابعة	compensated shadow mask mount	التعويض في درجة الحرارة
10 vision control room (video control room)	غرفة ضبط الإشارات الحاملة للصور (الفيديو)	23 centring (<i>Am.</i> centering) ring for the deflection system	حلقة المركز لنظام الانحراف
11 video controller (vision controller)	مراقب وحدة الفيديو	24 electron gun assembly	مجموعة مدفعة الكهأرب
12 camera monitor (picture monitor)	شاشة متابعة الكاميرا	25 rapid heat-up cathode	كاتود سريع التحارر
13 on-board telephone (intercommunication telephone)	هاتف العربية	26 television (TV) camera	كاميرا تصوير تليفزيوني (مصورة التليفزيونات)
14 microphone cables	كبيلات الميكروفونات	27 camera head	رأس الكاميرا
15 air-conditioning plant	وحدة مكيف الهواء	28 camera monitor	شاشة الكاميرا
		29 control arm (control lever)	ذراع تحكم
		30 focusing adjustment	آلية ضبط التركيز البصري
		31 control panel	لوحة تحكم
		32 contrast control	مضبط التباين
		33 brightness control	مضبط السطوع
		34 zoom lens	عدسة زوم
		35 beam-splitting prism (beam splitter)	منشور تقريق الحزمة الاشعاعية
		36 pick-up unit (colour, <i>Am.</i> colour, pick-up tube)	وحدة التقاط (أنبوب لاقط)
240 Broadcasting III (Television Engineering)	الإذاعة (الراديو والتلفزيون) (3)	241 Music Systems (Audio Systems) I	أنظمة الموسيقى (الأنظمة الصوتية) (1)
1 colour (<i>Am.</i> color) television (TV) receiver (colour television set) of modular design	مستقبل بترنيمات (تلفزيون) ألوان منقسم بنظام الموديولات	1-17 stereo system (hi-fi system), a midi system	نظام الصوت المنقسم (نظام الهاي فاي) جهاز الهاي فاي يغطاء واق من الأتربة
2 television cabinet	صندوق التلفزيون	1 hi-fi stack	مبيت له باب زجاجي
3 television tube (picture tube)	أنبوب الصورة	2 rack lid (rack dust cover, [housing] lid)	مشغل الأسطوانات
4 IF (intermediate frequency) amplifier module	موديول مضخم الصوت ذو تردد متوسط	3 rack (housing) with glass door	مشغل الأسطوانات
5 colour (<i>Am.</i> color) decoder module	موديول مستخلص الألوان	4 record player (record deck, analogue [<i>Am.</i> analog] record player)	مشغل الأسطوانات
6 VHF and UHF tuner	مؤلف ترددات عالية جداً وترددات منخفضة جداً موديول مزامنة أفقي	5 tuner (receiver, radio tuner)	مشغل الأسطوانات
7 horizontal synchronizing module	موديول الانحراف الرأسي	6 amplifier (power amplifier)	مشغل الأسطوانات
8 vertical deflection module	موديول ضبط الاستقامة الأفقي	7 double cassette deck (double cassette recorder)	مشغل الأسطوانات
10 horizontal deflection module	موديول الانحراف الأفقي	8 CD player (compact disc player)	مشغل الأقراص المنمنجة
11 control module	موديول تحكم	9 cassette rack	رفق تخزين الأشربة المنعلبة (الكاسيتات)
12 convergence module	موديول الانتمام	10 record and compact disc rack	حقيبة حفظ الأقراص المنمنجة
13 colour (<i>Am.</i> color) output stage module	موديول مخرج الألوان	11 castor	عجلة صغيرة
14 sound module	موديول الصوت	12 speaker (loudspeaker), a three-way bass reflex speaker	مكبر الصوت
15 colour (<i>Am.</i> color) picture tube	أنبوب الصورة الملونة	13 tweeter, a dome tweeter or piezo tweeter	مستطيق، مستطيق قبي أو بيذو
16 electron beams	حزم الكهأرب (الإلكترونات)	14 mid-range speaker (squawker)	سماعة متوسطة المدى
17 shadow mask with elongated holes	سائر مظل به ثقوب مطولة	15 bass speaker (woofer)	سماعة الجهير
18 strip of fluorescent (luminescent, phosphorescent) material	مورية فلورية		
19 coating (film) of fluorescent material	تكمية بمادة فلورية		
20 inner magnetic screen (screening)	مورية مغناطيسية داخلية		
21 vacuum	فراغ		
22 temperature-	محمل سائر مظل معادل		

16 port	فتحة	and automatic tuning	والمؤلفة الأوتوماتية
17 infrared remote control [unit] (IR remote control [unit])	وحدة تحكم عن بعد تعمل بالأشعة تحت الحمراء	49 amplifier (power amplifier)	مضخم صوت كهربائي
18 record player (record deck, analogue [<i>Am.</i> analog] record player)	مشغل الأسطوانات	50 function select buttons for the turntable, tuner, cassette deck (tape deck), CD player, and monitor (tape monitor)	أزرار انتقاء الوظيفة الخاصة بالقرص الدوار والمؤلف ومشغل شرائط الكاسيت ومشغل الأقراص المنمنجة
19 turntable with direct drive or belt drive	قرص الحاكي الدوار يعمل بإدارة مباشرة أو إدارة بسير	51 filter buttons (high and low filter buttons)	أزرار الفلاتر
20 strobe light (strobe speed control)	ضوء ومضي إلكتروني	52 bass control	مضبط الجهير
21 pitch control	ضبط الطبقة	53 treble control	مضبط التلاتي
22 rpm display	قراءة عدد الفلقات/دقيقة	54 balance control	مضبط التوازن
23 stop button	زر إيقاف	55 loudness button	مضبط الجهارة
24 auto-return button	زر إعادة الأسطوانة إلى البداية تلقائياً	56 volume control	مضبط حجم الصوت
25 rpm selector (speed selector)	زر ضبط سرعة دوران الأسطوانة	57 headphone socket	مقبس سماعات الرأس
26 cue button (down)	زر إشارة البدء (أسفل)	58 speaker select buttons	أزرار انتقاء سماعة الصوت
27 cue button (up)	زر إشارة البدء (أعلى)	59 LED display, a multi-function display	شاشة قراءة دبايود مضى متعددة الوظائف
28 stylus (needle)	إبرة الحاكي (إبرة)	60 function display	قراءة وظيفة التشغيل
29 pick-up	لاقط	61 receiver, a combined tuner-amp[ifier]	مستقبل (مؤلف ومضخم صوت معا)
30 size selector (record size selector)	مضبط حجم الأسطوانة	62 display select button	زر انتقاء قراءة الشاشة
31 tone arm (pick-up arm)	ذراع اللاقط	63 liquid crystal display (LCD), a multifunction display	شاشة قراءة بلورية سائلة
32 tone arm support (pick-up arm support)	مسند ذراع اللاقط	64 [graphic] equalizer, a 2 x 7 band [graphic] equalizer	مُعادل [جرافيتي]
33 stylus pressure control	مضبط ضغط إبرة الحاكي	65 equalizer slide controls	مضابيط المعادل الإنزلاقية
34 anti-skate control	مضبط منع الانزلاق	66 LED-display spectrum analyser	محل طيف الشاشة متعدد الأغراض دبايود مضى
35 tone arm counterweight (pick-up arm counterweight)	القلق الموازن لذراع اللاقط	67 headphones (stereo headphones)	سماعات الرأس (سماعات للصوت المنقسم)
36 lid (dust cover)	غطاء (وقاء التراب)	68 ear pads (ear cushions)	وسادة الأذن
37 tuner (receiver, radio tuner)	متعم، مؤلف (مستقبل، مؤلف راديو)	69, 70 microphones	ميكروفونات
38 power switch	مفتاح تشغيل / قفل الجهاز	69 directional microphone (stereo directional microphone)	ميكروفون اتجاهي
39 tuning button (tuning control)	زر الضبط الدقيق/المؤلفة	70 electret condenser microphone with omnidirectional pick-up characteristic	ميكروفون مكثف الكريت له خاصية التقاط الصوت من جميع الاتجاهات
40 manual and automatic tuning selection button with muting	زر انتقاء المؤلفة يدوياً أو أوتوماتياً مع آلية إخمات		
41 stereo/mono selection button	زر انتقاء الصوت المنقسم/المفرد		
42 strength-of-signal display button	زر قراءة قوة الإشارة		
43 memory button	زر الذاكرة		
44 station selection buttons	أزرار انتقاء المحطات		
45 frequency selection buttons ([wave] band selection buttons)	أزرار انتقاء نطاقات التردد		
46 station select display	شاشة عرض انتقاء المحطات		
47 fluorescent digital display indicating wave band, frequency, and strength of signal	قراءة فلورسنت رقمية توضح نطاق الموجة والتردد وقوة الإشارة		
48 LED indicator for stereo and mono mode	مؤشر بصمام ثنائي مضى للتشغيل المنقسم والمفرد		
		242 Music Systems (Audio Systems) II	أنظمة الموسيقى (الأنظمة الصوتية) (2)
		1 cassette deck (cassette recorder)	مُسجِّل الكاسيت
		2 power switch	مفتاح التشغيل
		3 [stop and] eject button	مفتاح الإيقاف وإخراج الشريط
		4 cassette holder (cassette drive, cassette transport)	حامل الشريط المُعلَب (إدارة الكاسيت)
		5 dust cover	غطاء واق من التراب
		6 counter (tape counter)	عُداد الشريط
		7-12 transport buttons	أزرار تدوير الشريط
		7 stop button	زر الإيقاف
		8 rewind button	زر إعادة لف الشريط

9	play buttons for both directions (bi-directional play buttons)	أزرار تشغيل الشريط لكلا الاتجاهين
10	fast forward button	زرّ تقديم الشريط
11	record button	زرّ التسجيل
12	pause button	زرّ توقيف الشريط مؤقتاً
13	counter reset button	زرّ إعادة ضبط العدّاد
14	noise reduction buttons (Dolby select buttons)	أزرار تقليل الضوضاء (أزرار انتقاء نظام الدولبي)
15	auto-reverse buttons	أزرار قلب الشريط تلقائياً
16	recording level control	مضبط مستوى التسجيل
17	microphone sockets	مقبّسات الميكروفون
18	headphone socket	مقبّس سماعات الرأس
19	level indicator display (VU meter), an LED display	شاشة دلالية لمستوى الصوت
20	tape type indicator (tape-bias indicator), an LED display	مؤشر نوع الشريط على الشاشة الدلالية
21	double cassette deck (double cassette recorder)	مُسجّل كاسيت مزدوج
22	play button	زرّ تشغيل الشريط
23	[stop and] eject button	زرّ الإيقاف وإخراج الشريط
24	high-speed dubbing button	زرّ دبلجة عالي السرعة
25	function select button	زرّ انتقاء وظيفة التشغيل
26	recording indicator light	ضوء مؤشر التسجيل
27	on-off light (power indicator light)	لمبة تشغيل/قفل الجهاز
28	CD player (compact disc player, digital compact disc player)	جهاز تشغيل الأقراص الممتدجة
29	CD drawer	درج القرص الممتدج
30	open/close button for the CD drawer	زرّ فتح/غلق درج القرص الممتدج
31	search button and index search button	زرّ البحث وزرّ البحث الإرشادي
32	skip buttons (skip-track buttons)	زرّ توقيف (زرّ قفز المسالك)
33	headphone volume control	مضبط حجم صوت سماعات الرأس
34	function select buttons	أزرار انتقاء وظيفة التشغيل
35	programming, track and disc repeat, and pause indicators	مؤشرات الترميز ومسالك الصوت وتكرار القرص وتوقيف القرص مؤقتاً
36	LED display	شاشة عرض مستوى تسجيل الصوت
37	remaining time and track-index indicators	مؤشرات الوقت المتبقي ودليل المسلك
38	portable radio recorder with integral CD player	جهاز تسجيل وراديو مشمول مزود بمسلك الأقراص الممتدجة
39	handle	مقبّض
40	[radio] receiver	مستقبّل [الراديو] (مستقبّل

(receiver and amplifier)	ومضخم الصوت)	
41	CD player	مُشغّل الأقراص الممتدجة
42	quartz clock with digital display and timer	ساعة كوارتز بشاشة رقمية وجهاز توقيت
43	double cassette recorder	مُسجّل كاسيت مزدوج
44	loudspeaker	سماعة صوت
45-49	audio-cassette (cassette)	شريط صوتي مُعلَب (كاسيت)
45-47	types of tape	أنواع الشريط
45	ferric cassette (iron oxide cassette, normal cassette)	كاسيت حديدية (كاسيت حديدي، كاسيت عادي)
46	chrome dioxide cassette (chrome cassette)	كاسيت كروم
47	metal cassette (metal oxide cassette)	كاسيت معدني
48	tape type indication (indicating hole)	مؤشّر نوع الشريط
49	record-protected cassettes	كاسيتات محمية من التسجيل عليها
50	world receiver for receiving ultra-short wave (USW), medium wave (MW), long wave (LW), and short wave (SW)	مستقبّل عالمي لاستقبال الموجات شديدة القصر والموجات المتوسطة والطويلة والقصيرة
51	aerial (rod aerial), telescopic aerial	هوائي، ايريال تليسكوبي
52	function buttons	أزرار وظائف التشغيل
53	station select buttons	أزرار انتقاء القنوات
54	manual tuning knob	زرّ الموائجة يدوياً
55	liquid crystal display (LCD) showing wave-band, frequency, and memory number	شاشة بلورية سائلة توضح نطاق الموجة والتردد ورقم الذاكرة
56	(sliding) volume control	مفتاح انزلاقي لضبط الصوت
57	cassette player (Walkman® with radio)	جهاز تشغيل شرائط الكاسيت
58	headphones	سماعات الرأس
59	equalizer, a 3-band equalizer	مُعادل، مُعادل 3 نطاقات
60	portable CD player (Discman®)	مُشغّل أقراص ممتدجة محمول
61	compact disc (CD)	شريط ممتدج
62	lid	غطاء
63	casing with transport, amplifier, display, and function buttons	غلاف وبه أزرار التشغيل ومُضخّم الصوت والشاشة
64	compact hi-fi system (compact stereo system)	نظام هاي فاي (عالي الأمانة/دقيق الأداء) ممتدج (نظام صوت مُجمّع ممتدج)
65	amplifier section	جزء مُضخّم الصوت
66	DAT recorder (digital cassette recorder) (DAT = Digital Audio Tape)	مُسجّل شرائط كاسيت صوتية رقمية

67	infrared sensor (IR sensor) for the remote control	جهاز إحساس يعمل بالأشعة تحت الحمراء للتشغيل عن بعد
68	input selection buttons for mono, analogue (Am. analog), and digital signals	أزرار انتقاء النّخل للإشارات المفردة والنظرية والرقمية
69	index and program selection buttons	أزرار دلالية وأزرار انتقاء البرامج
70	index number display	شاشة عرض الرقم الدلالي
71	auto-scan button	زرّ المسح الصوتي
72	end-record search button	زرّ البحث عن نهاية التسجيل
243 Video Equipment	مُعَدّات الفيديو	
1	camcorder (camera recorder), form: two-component system (separate camera and recorder)	كاميرا تسجيل صوت وصورة. الشكل نظام ثنائي المكونات (كاميرا ومسجل منفصلان)
2	pocket camcorder, a video-8 camcorder	كاميرا فيديو 8 ملم للجيب
3	lens, a × 6 zoom lens (11-66 mm)	عدسة زوم (11-66 ملم)
4	viewfinder (ocular)	مُحدّد الرؤية (عينية)
5	CCD image converter (image sensor) and high-speed shutter, a half-inch chip with shutter functions	مُحوّل صورة بينية شحنية القرن مع مغلاق عالي السرعة
6	video cassette	علبة شريط الفيديو
7	videotape	شريط الفيديو
8	head drum	أسطوانة رأس الفيديو
9	autofocus motor	موتور تلقائي البؤرية
10	built-in microphone (integral microphone)	ميكروفون داخلي
11	VHS head drum (VHS: Video Home System)	أسطوانة رأس الفيديو (نظام توجيه الإشارات الحاملة للصّور)
12	erase head	رأس مسح الإشارات الحاملة للصّور
13	guide pin	مسمار دلالي
14	tape guide	دليل الشريط
15	capstan	رُحوية
16	audio sync head	رأس التزامن الصوتي
17	pinch roller	أسطوانة تضيق
18	video head	رأس الفيديو
19	grooves in the wall of the head drum to promote air cushion formation	حزوز في رأس الفيديو لتعزيز تكون الوسادة الهوائية
20	VHS track format	تجهيز مسلك الإشارات الحاملة للصّور
21	direction of tape movement	اتجاه حركة الشريط
22	direction of recording	اتجاه التسجيل
23	video track, a slant track (only a few tracks shown)	مسلك الإشارات الحاملة للصّور
24	sound track (audio track)	مسلك الصوت
25	sync track	مسلك التزامن
26	sync head	رأس التزامن
27	sound head (audio head)	رأس الصوت
28	video head	رأس الفيديو
29	video recorder	جهاز تسجيل الفيديو
30	infrared remote control	تحكم عن بعد بالأشعة تحت الحمراء
31	program scale (program dial), a multi-display	مقياس البرامج
32	cassette compartment	خزانة علبة شريط الفيديو
33	jog shuttle knob for forward or reverse movement of the [video] picture	مقبّض يعمل بالدفع الخفيف لتحريك صورة [الفيديو] للأمام أو بالعكس
34	multidisc player	جهاز عرض متعدد الأقراص
35	infrared remote control	جهاز تحكم عن بعد بالأشعة تحت الحمراء
36	disc drawer	درج الأقراص
37-41	disc formats	أشكال تجهيز القرص
37	single compact disc (single CD)	قرص ممتدج مفرد
38	audio CD	قرص ممتدج صوتي
39	video CD	قرص ممتدج صوت وصورة
40	small laser disc (20 cm)	قرص ليزر صغير (20 سم)
41	large laser disc (30 cm)	قرص ليزر كبير (30 سم)
42	laser scanning system	نظام مسح بالليزر
43	[disc] spindle	عمود دوران [القرص]
44	laser-head tracing spindle	عمود تتبع رأس الليزر
45	laser head (laser unit)	رأس الليزر (وحدة الليزر)
244 Personal Computer (PC)	الحاسب الآلي الشخصي	
1	personal computer (PC; sim.: laptop)	الحاسب الآلي الشخصي
2	power switch	مفتاح التّيار
3	power supply (power pack)	إمداد الطاقة
4	housing	مبيت، صندوق
5	fixed-disk access light	لمبة الوصول إلى القرص الثابت
6	main memory	الذاكرة الرئيسية
7	coprocessor socket	مقبّس معالج مرافق
8	central processing unit (CPU), micro-processor	وحدة المعالجة المركزية
9	cache memory (cache controller)	ذاكرة مخفية
10	expansion memory slot	خيزر مُعدّ الذاكرة
11	graphics card slot	خيزر بطاقة الأشكال البيانية
12	combined fixed and floppy disk controller	مراقب قرص ثابت ومرن ممتدج
13	serial and parallel	بطاقة اتصال متتابع-متواز

(electronic calculator)	تليفون ، هاتف
13 telephone, an executive-secretary system	تليفون ، هاتف
14 dial; also. push-button keyboard	قُرْصٌ: أيضاً لَوْحَة أزرار انضغاطية
15 call buttons	أزرار الاتصال
16 receiver (telephone receiver)	ساعة (ساعة الهاتف)
17 dictating machine	المَلَمَة ، الدكاتفون
18 position indicator	مَبِينُ المَوْع
19 control buttons (operating keys)	مفاتيح التشغيل
20 cabinet	خزانة
21 visitor's chair	كُرْسِيّ الزائر
22 safe	خزينة
23 bolts	أليّة قفل الخزينة (ترايبس)
24 armour-plated (<i>Am.</i> armor-plated) lock area	منطقة قفل مدوّعة
25 confidential documents	مستندات سرّية
26 patent	براءة اختراع
27 petty cash	نقد الترتيبات
28 picture	صورة
29 bar (drinks cabinet)	بار (صُوان المشروبات)
30 bar set	طاقم أكواب البار
31-36 conference grouping	طاقم حجره الاجتماعات
31 conference table	طاولة الاجتماعات
32 pocket-sized dictating machine, a micro-cassette recorder	مِلَمَة صغيرة للجيب ، جهاز تسجيل صغير
33 ashtray	مِبْفَضَة السجائر
34 corner table	طاولة الزاوية
35 table lamp	مصباح الطاولة (أباجورة)
36 two-seater sofa [part of the conference grouping]	كَنْبَة ذات مَعْدَنَيْن [جزء من طاقم حجره الاجتماعات]
247 Office III	المَكْتَب (3)
1-44 office equipment (office supplies, office materials)	المستلزمات المكتبية
1, 2 paper clips	مَشابك ورَق
3 punch	خزّامة الورق
4 stapler (stapling machine)	دباسة
5 anvil	سَدَان
6 spring-loaded magazine	مَخْزَنٌ محمول على نابض
7 type-cleaning brush	فرشاة تنظيف حروف الآلة
8 type cleaner (type-cleaning kit)	طاقم تنظيف أحرف الآلة
9 fluid container (fluid reservoir)	وعاء السائل
10 cleaning brush	فرشاة تنظيف
11 felt tip pen	قلم حبر ذو سن لبادي
12 correcting paper [for typing errors]	ورق تصحيح [الأخطاء الطباعية]
13 correcting fluid [for typing errors]	سائل تصحيح [الأخطاء الطباعية]

المكّتب (2)

مكّتب المسؤول التنفيذي
 كُرْسِيّ دَوّار
 مكّتب
 سلّم المكّتب
 درج المكّتب
 صوان له باب ، الدرج الكبير
 نَشَاقَة المكّتب
 خطاب تجاري
 يَوْمِيَة تسجيل المواعيد
 طاقم المكّتب
 جهاز اتصال داخلي (انتر كوم مكّتب)
 مِصْبَاح المكّتب
 آلة حاسبة للجيب

246 Office II

1-36 executive's office
 1 swivel chair
 2 desk
 3 desk top
 4 desk drawer
 5 cupboard (storage area) with door
 6 desk mat (blotter)
 7 business letter
 8 appointments diary
 9 desk set
 10 intercom (office intercom)
 11 desk lamp
 12 pocket calculator

المكّتب (1)

مكّتب موظف الاستقبال (مكّتب السكرتير)
 جهاز الفاكسميلي
 رسالة مرّسَلَة أو مَسْتَقْبَلَة
 نتيجَة / روزنامَة حائط
 خِزَانَة الملفات
 باب دَفْعِي

communication card	لوّح القاعدة
14 PC tower interior view	ذراع الوصول (جهاز التشغيل)
15-67 peripherals	رأس القراءة أو الكتابة
15-32 built-in devices	مُحَرِّك إدارة الأسطوانات الألو منيوم
15 keyboard	أسطوانات ألو منيوم مَمَغْنَطَة
16 function keys	مُحَرِّك إدارة رأس القراءة أو الكتابة
17 letter keys and number keys (numeric keys)	ناقل البيانات والعناوين وأوامر التحكم
18 enter key (return key)	وحدة الشريط الممغنت
19 cursor keys	شريط ممغنت
20 number [key] pad (numeric [key] pad)	بكرة الشريط الممغنت
21 mouse	كاسيت الشريط الممغنت
22 mouse buttons	عمود إدارة
23 trackerball (trackball)	شريط إدارة
24 handrest	مُحَرِّك إدارة
25 roller ball	أجهزة الإخراج
26 digitizing tablet (digitizer; also: graphics tablet)	شاشة ، شاشة مَلَوّنة عالية الوضوح
27 graphics area	شريط ممغنت
28 cross hairs	بكرة الشريط الممغنت
29 receiving grids	كاسيت الشريط الممغنت
30 scanner	عمود إدارة
31 control panel with function keys	شريط إدارة
32 scanning surface	مُحَرِّك إدارة
33-59 mass storage devices (magnetic stores, magnetic memories)	أجهزة تخزين ذات سعة كبيرة (ذاكرات مغناطيسية)
33-44 disk drives (drives, floppy disk drives)	مَشغَلَات الأقراص
33 minifloppy disk drives (5 1/4 inch [floppy] disk drive)	مَشغَلَات القرص المرن الصغير (مشغل قرص 5.25 بوصة)
34 latch	سَقَابَة
35 microfloppy disk drive (3 1/2 inch [floppy] disk drive)	مَشغَلُ القرص المرّن الصغير (مشغل قرص 3.5 بوصة)
36-44 diskettes (disks, floppy disks, floppies)	الأقراص المرنة الصغيرة
36 minifloppy (minifloppy disk, 5 1/4 inch disk, flexible disk)	قُرْصٌ حَرْنٌ صَغِيرٌ (قرص 5.25 بوصة)
37 label	بطاقة العنوان
38 write-protect notch	فِرْزَة حماية الكتابة
39 hole for engaging the drive hub	ثَقْبٌ لتثبيت صُرّة بكرة الشريط المغناطيسي
40 registration hole	ثَقْبُ التَّأطِير
41 disk cover (envelope)	ظرف القُرْص
42 access slot for the read-write head	حَيْرُ الوصول إلى رأس القراءة أو الكتابة
43 microfloppy (3 1/2 inch [floppy] disk)	قُرْصٌ حَرْنٌ صغير (قرص 3.5 بوصة)
44 sliding shutter	مِغْلَاق انزلاقي
45 fixed-disk drive (fixed disk, hard disk)	مَشغَلُ القُرْص الثابت (القرص الصلب)

14 electronic pocket calculator	آلة حاسبة إلكترونية للجيب	10 filing shelves	رفف حفظ الملفات	golf ball typewriter		unit	آلية فرز
15 eight-digit fluorescent display	شاشة عرض مضئية سعة ثمانية أرقام	11 clerical assistant's desk	مكتب مساعداً الكاتبة	2-6 keyboard	لوحة المفاتيح	38 sorter	صفايح خروج الشنخ العسورة
16 on/off switch	مفتاح التشغيل/الإيقاف	12 office cupboard	صوان مكتبي	2 space bar	قضيب المبادعة بين الحروف والكلمات	39 copy delivery bins	شاشات لوحة التحكم ومفاتيح التحكم
17 function keys	مفاتيح التشغيل/الإيقاف	13 plant stand (planter)	حاويل النباتات، حوض نباتات	3 shift key	مفاتيح الحروف العليا	40-43 control panel displays and control keys	مفاتيح التكبير والتصغير واتقاء البرامج
18 number keys	مفاتيح الأرقام	14 indoor plants (house-plants)	نباتات ظل (نباتات منزلية)	4 line space and carrier return key	مفتاح المسافة بين الأسطر والانتقال إلى أول السطر التالي	40 enlargement, reduction, and program selection keys	مفاتيح انتقاء وظيفة الفرز وتصوير صفحتي الكتاب
19 decimal key	مفتاح العلامة العشرية	15 programmer	مترجم الكمبيوتر	5 shift lock	مفتاح قفل مفاتيح الحروف العليا	41 sort mode and two-sided copy keys	شاشة عرض مزودة بمفاتيح انتقاء الألوان والتعرض للضوء وعدد الشنخ
20 'equals' key	مفتاح علامة =	16 data display terminal (visual display unit)	طرفية عرض البيانات (وحدة عرض مرئي)	6 margin release key	مفتاح إطلاق الهامش الجانبي	42 display with colour, exposure, format and copy number selection keys	مفتاح بدء التصوير
21 instruction keys (command keys)	مفاتيح التعليمات/الأوامر	17 customer service representative	ممثل خدمة العملاء	7 tabulator key	مفتاح إطلاع الهامش الجانبي	43 start key (copy start key)	ماكينة طي الخطابات
22 memory keys	مفاتيح الذاكرة	18 customer	عميل (زبون)	8 tabulator clear key	مفتاح إلغاء الجدولة	44 letter-folding machine	إلغاء الورق
23 percent key (percentage key)	مفتاح النسبة المئوية	19 computer-generated design	تصميم على الكمبيوتر	9 on/off switch	مفتاح التشغيل/الإيقاف	45 paper feed	آلية الطي
24 π-key (pi-key) for mensuration of circles	مفاتيح حساب مساحة وأحجام الدوائر	20 sound-absorbing partition	حاجز ماص للصوت	10 striking force control (impression control)	أداة التحكم في درجة (حبر) الطباعة	46 folding mechanism	لوحة استقبال الورق المطبوع
25 pencil sharpener	ميراة الأقلام الرصاص	21 typist	طابعة على الآلة الكاتبة	11 ribbon selector	أداة اختيار الشريط	47 receiving tray	ماكينة طباعة أوفست صغيرة
26 typewriter rubber	مخفا الآلة الكاتبة	22 typewriter	آلة كاتبة	12 margin scale	مقياس مدرج لتحديد الهامش	48 small offset press	لوحة تعديل ماكينة بالورق الطباعي
27 adhesive tape dispenser	أداة سحب الشريط اللاصق	23 filing drawer	درج حفظ الملفات	13 left margin stop	أداة إيقاف الهامش الأيسر	49 paper feed	ذراع تعبئة أسطوانة السطح وحدة تحبير
28 adhesive tape holder (roller-type adhesive tape dispenser)	حاويل الشريط اللاصق	24 customer card index	فهرس بطاقات العملاء	15 golf ball (spherical typing element) bearing the types	أداة إيقاف الهامش الأيمن	50 lever for inking the plate cylinder	51-52 inking unit (inker unit)
29 roll of adhesive tape	بكرة شريط لاصق	25 office chair, a swivel chair	كرسي المكتب، كرسي دوران	16 ribbon cassette	مكتب الطباعة على الآلة الكاتبة	51 distributing roller (distributor)	طنبور توزيع الحبر
30 tear-off edge	حافة قطع الشريط اللاصق	26 typing desk	مكتب الطباعة على الآلة الكاتبة	17 paper bail with rollers	صندوق فهرس البطاقات	52 ink roller (inking roller, fountain roller)	أسطوانة التصبير
31 moistener	وعاء إسفنجة الترطيب	27 card index box	صندوق فهرس البطاقات	18 platen	أرفف متعددة الأغراض مالك/صاحب المؤسسة	53 pressure adjustment	آلية ضبط طنبور الطباعة (الطنبور الضاغط)
32 desk diary	يومية مكتب	28 multi-purpose shelving	أرفف متعددة الأغراض	19 typing opening (typing window)	مكتب/صاحب المؤسسة خطاب تجاري	54 sheet delivery (receiving table)	وحدة استقبال الورق المطبوع
33 date sheet (calendar sheet)	ورقة التاريخ، ورقة تقويم	29 proprietor	مالك/صاحب المؤسسة	20 paper release lever	سكرتير صاحب المؤسسة	55 printing speed adjustment	آلية تعديل سرعة الطباعة
34 memo sheet	ورقة كتابة المذكرات	30 business letter	خطاب تجاري	21 carrier return lever	إضمامة ورق الاختزال	56 jogger for aligning the piles of sheets	آلية ترصيص الورق
35 ruler	مسطرة	31 proprietor's secretary	سكرتير صاحب المؤسسة	22 platen knob	إضمامة ورق الاختزال	57 pile of paper (pile of sheets)	رصه ورق
36 centimetre and millimetre (Am. centimeter and millimeter) graduations	تدرج السنتيمتر والميليمتر	32 shorthand pad (Am. steno pad)	إضمامة ورق الاختزال	23 line space adjuster	طابعة صوتية	58 folding machine	ماكينة طي الورق
37 file (document file)	حافظة مستندات	33 audio typist	طابعة صوتية	24 variable platen action lever	الميللة، الدكافون	59 gathering machine (collating machine, assembling machine) for short runs	ماكينة تجميع ملامر
38 spine label (spine tag)	بطاقة كعب الحافظة	34 dictating machine	الميللة، الدكافون	25 push-in platen variable	ساعة الأذن	60 gathering station (collating station, assembling station)	محلّة التجميع
39 finger hole	فتحة إصبع	35 earphone	مخفط إحصائي	26 erasing table	قلمة أثاث تحتوي على خزانة أو أدراج	61 adhesive binder (perfect binder) for hot adhesives	ماكينة تغليف كامل
40 arch board file	حافظة ذات لوح قوسي	36 statistics chart	مخفط إحصائي	27 transparent cover	خزانة ذات باب انزلاقي	62 magnetic tape dictating machine	ميللة ذات شريط مغناطيسي
41 arch unit	وحدة قوسية	37 pedestal containing a cupboard or drawers	قلمة أثاث تحتوي على خزانة ذات باب انزلاقي	28 exchange golf ball (exchange typing element)	أثاث مكتبي في ترتيب زاوي	63 headphones (headset, earphones)	ساعة الأذن
42 release lever (locking lever, release/lock lever)	ذراع اعتاق / قفل المشبك القوسي	38 sliding-door cupboard	خزانة ذات باب انزلاقي	29 type	رف معلق بالجدار	64 on/off switch	مفتاح التشغيل/الإيقاف
43 compressor	لوح ضاغط	39 office furniture arranged in an angular configuration	أثاث مكتبي في ترتيب زاوي	30 golf ball cap (cap of typing element)	صينية الخطابات		
44 bank statement (statement of account)	كشف حساب من البنك	40 wall-mounted shelf	رف معلق بالجدار	31 teeth	روزنامة حائط، نتيجة حائط		
		41 letter tray	صينية الخطابات	32 photocopier (copier, photocopying machine)	مركز المعلومات		
		42 wall calendar	روزنامة حائط، نتيجة حائط	33 copyboard cover with single-copy (single-sheet) delivery tray	استدعاء المعلومات على طرفية عرض البيانات		
		43 data centre (Am. center)	مركز المعلومات	34 universal paper cassette			
		44 calling up information on the data display terminal (visual display unit)	استدعاء المعلومات على طرفية عرض البيانات	35 adjustable paper cassettes			
		45 waste paper basket	سلة المهملات	36 front door			
		46 sales statistics	إحصائيات المبيعات	37 dual vertical transport			
		47 EDP print-out, a continuous fan-fold sheet	ورق طباعة الكمبيوتر مطوي على شكل مروحة				
		48 connecting element	قطعة توصيل				
		249 Office V (Office Machinery)	المكتب (5) معدّات مكتبية				
		1 electric typewriter, a	آلة كاتبة كهربائية				

بلجيكا 100 فرنك
لكسمبورج أفرنك
هولندا 2 1/2 جلدري
الجلدري = 100 سنت
إيطاليا 200 ليرة
مدينة الفاتيكان 100 ليرة
أسبانيا 100 بزيٲا = 100 سنتيمو
البرتغال 100 اسكودو = 100 سنتافو
الدانمارك 1 كرون = 100 أور
السويد 1 كرونة = 100 أور
النرويج 1 كرون = 100 أور
تشيكوسلوفاكيا 1 تشيكوسلوفاكيا 1 كورونا
يوغسلافيا 1 دينار = 100 بارا
29 المملكة المتحدة لبريطانيا العظمى وأيرلندا الشمالية
جنوبي إيرلندي = 100 بنس
الأوراق المالية (النفود الورقية وأذن الخزائنة)
جمهورية ألمانيا الاتحادية
100 مارك ألماني
بنك الإصدار
العلامة المائية (صورة شخص)
قيمة العملة
الولايات المتحدة الأمريكية
1 دولار أمريكي = 100 سنت
صورة طبق الأصل من التوقيع
خاتم مطبوع بالضغط
الرقم المسلسل
اليونان 1000 دراخمة
1 دراخمة = 100 لبتون
صورة لشخص
سك العملات المعدنية
سك العملة
قالبا سك العملة
القالب العلوي
القالب السفلي
طوق

17 Belgium: 100 francs
18 Luxembourg (Luxemburg): 1 franc
19 Netherlands: 2 1/2 guilders; 1 gulder (florin, gulden) = 100 cents
20 Italy: 200 lire (sg. lira)
21 Vatican City: 100 lire (sg. lira)
22 Spain: 1 peseta = 100 céntimos
23 Portugal: 1 escudo = 100 centavos
24 Denmark: 1 krone = 100 øre
25 Sweden: 1 krona = 100 öre
26 Norway: 1 krone = 100 øre
27 Czechoslovakia: 1 koruna = 100 heller
28 Yugoslavia: 1 dinar = 100 paras
29 United Kingdom of Great Britain and Northern Ireland: 1 pound sterling (£1) = 100 new pence (100 p); (sg. new penny, new p)
30-39 banknotes (Am. bills) (paper money, notes, treasury notes)
30 Federal Republic of Germany: 100 DM
31 bank of issue (bank of circulation)
32 watermark [a portrait]
33 denomination
34 USA: 1 dollar (\$) = 100 cents
35 facsimile signatures
36 impressed stamp
37 serial number
38 Greece: 1,000 drachmas (drachmae); 1 drachma = 100 lepta (sg. lepton)
39 portrait
40-44 striking of coins (coinage, mintage)
40-41 coining dies (minting dies)
40 upper die
41 lower die
42 collar

الأسهم بالبنك
توقيع رئيس مجلس المحافظين
توقيع رئيس مجلس الإدارة
فرخ كورونات أرباح الأسهم
كوبون ربح الأسهم
كعب فرخ كورونات الأرباح
النفود (العملات المعدنية والأوراق المالية)
العملات المعدنية
أنواعها ذهب، فضة، نيكل، نحاس، ألومنيوم
أثينا الدراخمة الرباعية
البومة (رمز مدينة أثينا)
إكليل قسطنطين الأعظم
عملة الإمبراطور فريدريك الأول الأعظم
لويس الرابع عشر بروسيا 1 رايخستالر يحمل صورة فردريك الأعظم
جمهورية ألمانيا الاتحادية
5 ماركات ألمانية
1 مارك = 100 فنتين
وجه القطعة النقدية
الجانب الآخر للعملة (ظهر القطعة النقدية)
النقش المضروب على العملة المعدنية
نقش (نقش حافة العملة)
شعار، شعار نبالة محلي
النمسا 25 شلداً، 1 شن = 100 جروش
شعار نبالة محلي
سويسرا 5 فرنكات
1 فرنك = 100 سنتيم
فرنسا 1 أفرنك = 100 سنتيم

in bank's share register (bank's stock ledger)
15 signature of the chairman of the board of governors
16 signature of the chairman of the board of directors
17 sheet of coupons (coupon sheet, dividend coupon sheet)
18 dividend warrant (dividend coupon)
19 talon
252 Money (Coins and Notes, Am. Coins and Bills)
1-29 coins (coin, coinage, metal money, specie, Am. hard money); kinds: gold, silver, nickel, copper, or aluminium, Am. aluminium, coins
1 Athens: tetradrachm (tetradrachmon, tetradrachma)
2 the owl [emblem of the city of Athens]
3 aureus of Constantine the Great
4 bracteate of Emperor Frederick I Barbarossa
5 Louis XIV louis-d'or
6 Prussia: 1 reichstaler (speciestaler) of Frederick the Great
7 Federal Republic of Germany: 5 Deutschmarks (DM); 1 DM = 100 pfennigs
8 obverse
9 reverse (subordinate side)
10 mint mark (mintage, exergue)
11 legend (inscription on the edge of a coin)
12 device (type), a provincial coat of arms
13 Austria: 25 schillings; 1 sch = 100 groschen
14 provincial coats of arms
15 Switzerland: 5 francs; 1 franc = 100 centimes
16 France: 1 franc = 100 centimes

قبول
بطاقة اشتمان "يورتشك"
بنك الإصدار (البنك المسحوب عليه)
رقم الحساب
رقم البطاقة
هولوجرام، صورة مجسمة
شريط ممغنط (من الخلف)
بورصة الأوراق المالية
بورصة الأوراق المالية
قاعة البورصة
سوق الأوراق المالية
مكتب السمسار
سمسار معتمد بالبورصة
سمسار سوق غير رسمية، سمسار تجاري يتعامل في الأوراق غير المدرجة بالبورصة
وسيط في البورصة
وكيل بالبورصة، موظف بنك
لوحة عرض الأسعار
مُخْتَصِرٌ إرشادي
كُتْكُ التليفون (كُتْكُ الهاتف)
الأوراق المالية: أنواعها
أشهُم ، شهادات الدُخْل الثابت ، شهادات الدُخْل السنوي ، صكوك ، صكوك أسهم ، صكوك تجارية ، صكوك صناعية ، صكوك قابلة للتحويل
شهادة أسهُم ، هنا سهُم لحامله (ضمن أسهُم)
سعر التعادل أو السُعر الاسمي للسهُم
رقم مسلسل
رقم صفحة القيد في سجل

23 acceptance
24 Eurocheque card
25 issuing bank (drawee bank)
26 account number
27 card number
28 hologram, a white light hologram (rainbow hologram)
29 (on the back:) magnetic strip
251 Stock Exchange
1-10 stock exchange
1 exchange hall (exchange floor)
2 market for securities
3 broker's post
4 sworn stockbroker (exchange broker, stockbroker, Am. specialist), an inside broker
5 kerbstone broker (kerbstoner, curbstoner, outside broker), a commercial broker dealing in unlisted securities
6 member of the stock exchange (stockjobber, Am. floor trader, room trader)
7 stock exchange agent (boardman), a bank employee
8 quotation board
9 index curve
10 telephone box (telephone booth, telephone kiosk, call box)
11-19 securities; kinds: share (Am. stock), fixed-income security, annuity, bond, debenture bond, municipal bond (corporation stock), industrial bond, convertible bond
11 share certificate (Am. stock certificate); here: bearer share (share warrant)
12 par (par value, nominal par, face par) of the share
13 serial number
14 page number of entry

حامل الميكروفون
مقيس تحكّم سفلي
مقيس مهائى الهاتف
مقيس سماعة الأذن
مقيس الميكروفون
مكبر صوت داخلي
لمبة إرشادية
حَجَبَةٌ شريط التسجيل
أزرار لف وتقديم وإيقاف الشريط
مقياس زمني مدرج
أداة إيقاف المقياس الزمني
البنك/المصرف
القاعة الرئيسية
شباك الصراف
الصراف
زجاج مقاوم للرصاص
مكتب خدمة العملاء (للتقديم الخدمات المصرفية والاستشارات الخاصة بالحصائب الادخارية وحصائب الافراد والشركات والقروض الشخصية)
موظفة بالبنك
عميل
كتيّبات
قائمة أسعار الأسهم والأوراق المالية بالبورصة
كاونتر صرف النقد الأجنبي (استبدال العملة)
مدخل الغرفة المنيعه (غرفة حفظ النقاش والأموال)
ورقة تجارية، هنا كميالية، قبول مصرفي
مكان الإصدار
تاريخ الإصدار
مكان السداد
تاريخ الاستحقاق
شُرْطُ الكميالية
القيمة
المُدْفوع له (المستفيد)
المسحوب عليه (دافع)
الكميالية)
الساحب
الوكيل الدافع

65 microphone cradle
66 foot control socket
67 telephone adapter socket
68 headphone socket (earphone socket, headset socket)
69 microphone socket
70 built-in loudspeaker
71 indicator lamp (indicator light)
72 cassette compartment
73 forward wind, rewind, and stop buttons
74 time scale with indexing marks
75 time scale stop
250 Bank
1-11 main hall
1 cashier's desk (cashier's counter)
2 teller (cashier)
3 bullet-proof glass
4 service counters (for service and advice on savings accounts, private and company accounts, personal loans)
5 bank clerk
6 customer
7 brochures
8 stock list (price list, list of quotations)
9 information counter
10 foreign exchange counter
11 entrance to strong room
12 bill of exchange (bill); here: a draft, an acceptance (bank acceptance)
13 place of issue
14 date of issue
15 place of payment
16 date of maturity (due date)
17 bill clause (draft clause)
18 value
19 payee (remittee)
20 drawee (payer)
21 drawer
22 domiciliation (paying agent)

القوات المسلحة (الجيش)
أسلحة الجيش

- 1) **الأسلحة اليدوية**
سدس بي 1
سبطانة، ماسورة
مسددة أمامية
الطارق، التت
الزناد
قبضة المسدس
حاجس المخرن
المرشاش الخفيف إم بي 2
مسند الكتف (الإخصص،
الديشك)
غلاف أية التعمير والإطلاق
جلبية تثبيت السبطانة/
الماسورة
ذراع التعمير
مسند اليد
ذراع سقافة الأمان
مخرن الذخيرة
البندقية "جي 3 إيه 3"
ذاتية التعمير
كانت الوميض
أية الزناد
فتحة المسددة/الناشكة
الخلفية
مجموعة المسددة الأمامية
والشعيرة
إخصص/ديشك البندقية
قاذف صواريخ خفيفة
طراز 2.44 إيه 1 مضادة
للديابات
صاروخ (مقدوف)
سدادة تليسكوبية
مسند الخد
مدفع رشاش "إم جي 3"
مخفف الارتداد
قلابة تغيير الحصالة
أسلحة مدفعية محمولة
على عربات مدافع
متحركة
مدفع هوبنر متحرك طراز
"إس إف إم 110 إيه 2"
عربة المدفع
عجلة الدفع
جنزير
عجلة السير على الطريق
يدن العربة
غازز الخاضن
مكبس غازز الحاضن
نظام هيدرولي

- 255 Armed Forces 1 (Army)**
1-96 army armament
(army weaponry)
1-28 hand weapons
1 P1 pistol
2 barrel
3 front sight (foresight)
4 hammer
5 trigger
6 pistol grip
7 magazine holder
8 MP2 submachine gun
9 shoulder rest (butt)
10 casing (mechanism casing)
11 barrel clamp (barrel-clamping nut)
12 cocking lever (cocking handle)
13 palm rest
14 safety catch
15 magazine
16 G3-A3 self-loading rifle
17 flash hider (flash eliminator)
18 trigger mechanism
19 notch (sighting notch, rear sight)
20 front sight block (fore-sight block) with front sight (foresight)
21 rifle butt (butt)
22 44 2A1 light anti-tank rocket launcher
23 rocket (projectile)
24 telescopic sight (telescope sight)
25 cheek rest
26 MG3 machine gun (Spandau)
27 recoil booster
28 belt-changing flap
29-61 **artillery weapons**
mounted on self-propelled gun carriages
29 SFM 110 A2 self-propelled howitzer
30-32 **gun carriage**
30 drive wheel
31 track
32 road wheel
33 hull
34 spade
35 spade piston
36 hydraulic system

- نصف رجل، أيضا نصف امرأة
تويج، إكليل
شعار ملوك فرنسا (قديمًا)
غطاء شعار النبالة
حامل الشعار
ثور
أحدادي القرن (حصان خرافي)
شعار نبالة
درع المنتصف (درع القلب)
أقسام الترس من 1 إلى 6
الجزء الأيمن من الترس
الجزء العلوي من الترس
الجزء الأيسر من شعار النبالة
الأصماغ
المعدان
ذهبي [أصفر]
فضي [أبيض]
أسود، غامق
أحمر
سماوي، لازوردي
أخضر
ريش النعام
صوّلجان، عصا
نصف ماعز
رايات مبارزات الفرسان
قرنًا الجاموس
الخفاف (مخلوق خرافي)
مجموعة ريش الطاوس
الثّجان
والنّوجيات/الأكاليل
[طراز قاري]
تاج البابا المزمع بالجواهر
التاج الإمبراطوري [في ألمانيا حتى عام 1806]
تويج الدوق
تويج الأمير
تويج الناخب
التاج الملكي الإنجليزي
تويجات الرّيب
تويج البارونيتية
تويج البارونية
تويج الكونتية
تاج قمة سور المدينة

- 11 demi-man; *also*: demi-woman
12 crest coronet
13 fleur-de-lis
14 heraldic tint (mantling)
15-16 **supporters**
(heraldic beasts)
15 bull
16 unicorn
17-23 **blazon**
17 inescutcheon (heart-shield)
18-23 **quarterings one to six**
18, 20, 22 dexter (right)
18-19 chief
19, 21, 23 sinister (left)
22-23 base
24-29 tinctures
24-25 metals
24 or (gold) [yellow]
25 argent (silver) [white]
26 sable
27 gules
28 azure
29 vert
30 ostrich feathers (treble plume)
31 truncheon
32 demi-goat
33 tournament pennons
34 buffalo horns
35 harpy
36 plume of peacock's feathers
37, 38, 42-46 **crowns and coronets** [continental type]
37 tiara (papal tiara)
38 Imperial Crown [German, until 1806]
39 ducal coronet (duke's coronet)
40 prince's coronet
41 elector's coronet
42 English Royal Crown
43-45 **coronets of rank**
43 baronet's coronet
44 baron's coronet (baronial coronet)
45 count's coronet
46 mauerkrone (mural crown) of a city crest

- الحزف P، علم الإبحار ("أعلى وشك الإبحار")
الحزف W ("I require medical assistance")
الحزف Z، راية بحرية مستطيلة
راية كودية، تستخدم في نظام الإشارات الدولي
الرايات البديلة، الرايات المثلثة
الرايات البحرية الرقمية
رقم 1
رقم صفر
أعلام الحمامك
راية قارب الحمامك
"السفينة أنهت الإجراءات الجمركية"
راية إشارة الحمامك
راية البارود ["أشحة قابلة للاشتعال"]
شعارات النبالة
والتّيجان والنّوجيات
شعارات النبالة
شارات
رمز الإمارة أو الملك
شارة
إكليل الألوان
غطاء
خوذات
خوذة مائلة (خوذة المبارزة على ظهر الخيل)
درع
تويج أمير متخني
خوذة معدنية كروية
خوذة شبكية
خوذة ذات فتحة أمامية لها جزء متحرك
الشعارات الرّيجية
شعار نبالة الزّوج
شعار نبالة أسرة الرّوجة

- 26 P, the Blue Peter ("about to set sail")
27 W ("I require medical assistance")
28 Z, an oblong pennant (oblong pendant)
29 code pennant (code pendant), used in the International Signals Code
30-32 **substitute flags**
(repeaters), triangular flags (pennants, pendants)
33-34 **numeral pennants**
(numeral pendants)
33 number 1
34 number 0
35-38 **customs flags**
35 customs boat pennant (customs boat pendant)
36 'ship cleared through customs'
37 customs signal flag
38 powder flag
["inflammable (flammable) cargo"]
254 Heraldry, Crowns and Coronets
1-36 **heraldry** (blazonry)
1, 11, 30-36 **crests**
1-6 **coat-of-arms** (achievement of arms, hatchment, achievement)
1 crest
2 wreath of the colours (*Am.* colors)
3 mantle (mantling)
4, 7-9 **helmets** (helms)
4 tilting helmet (jousting helmet)
5 shield
6 bend sinister wavy
7 pot-helmet (pot-helm, heaume)
8 barred helmet (grilled helmet)
9 helmet affronty with visor open
10-13 **marital achievement** (marshalled, *Am.* marshaled, coat-of-arms)
10 arms of the baron (of the husband)
11-13 **arms of the family of the femme** (of the wife)

- قُرص الغملة
مكبس سك الغملة
الأعلام
علم الأمم المتحدة
صاري العلم يعلوه قرص الحبال
الكرّ
حبل رفع العلم أو إنزاله
قماش راية ملّون
علم المجلس الأوروبي
العلم الأولمبي
علم مكبس [رمز الحجاب]
العلم
صاري العلم
نقوش زخرفية
شريط طويل ملّون
الطرف المدب لصاري العلم
قماش الراية المدبّ
راية، بيرق
راية سلاح الفرسان
راية رئيس ألمانيا الاتحادية
الأعلام القومية
العلم البريطاني (بريطانيا العظمى)
العلم الفرنسي (فرنسا)
علم الدانمارك
علم الولايات المتحدة الأمريكية
الهِلال (تُرْكِيَا)
النمّس الشّقرّة (اليابان)
المطرقة والمبجل (علم اتحاد الجمهوريات الاشتراكية السوفيتية)
رايات الإشارات
رايات الحروف
الحزف A، علم مركب تجاري
الحزف G، علم إرشاد السفن في المرافئ
الحزف H ("pilot on board")
مثنى السفينة (")
الحزف L ("you should stop, I have something important to communicate")
ك

- Community / مجتمع
43 coin disc (flan, planchet, blank)
44 coining press (minting press)
253 Flags
1-3 flag of the United Nations
1 flagpole (flagstaff) with truck
2 halyard (haliard, haul-yard)
3 bunting
4 flag of the Council of Europe
5 Olympic flag
6 flag at half-mast (*Am.* at half-staff) [as a token of mourning]
7-11 **flag**
7 flagpole (flagstaff)
8 ornamental stud
9 streamer
10 pointed tip of the flagpole
11 bunting
12 banner (gonfalon)
13 cavalry standard (flag of the cavalry)
14 standard of the German Federal President [ensign of head of state]
15-21 **national flags**
15 the Union Jack (Great Britain)
16 the Tricolour (*Am.* Tricolor) (France)
17 the Danebrog (Dannebrog) (Denmark)
18 the Stars and Stripes (Star-Spangled Banner) (USA)
19 the Crescent (Turkey)
20 the Rising Sun (Japan)
21 the Hammer and Sickle (USSR)
22-34 **signal flags, a hoist**
22-28 **letter flags**
22 letter A, a burgee (swallow-tailed flag)
23 G, pilot flag
24 H ("pilot on board")
25 L ("you should stop, I have something important to communicate")
872

37 elevating piston	مَكْبَس ضبط الارتفاع
38 breech ring	حلقة الترياس
39 barrel	ماسورة، سبطانة
40 muzzle	فوهة الماسورة
41 buffer (buffer recuperator)	مُخَفِّف الارتداد
42 M 109 A3 G self-propelled howitzer	مدفع هاوتزر متحرك طراز "إم 109 إيه 3 جي"
43 armoured (Am. armored) turret	برج مدرع
44 fighting compartment	حجيرة القتال
45 barrel clamp	جِلْبَة تثبيت الماسورة
46 fume extractor	آلية إطلاق الدخان
47 barrel recuperator	جهاز ارتداد الماسورة
48 light anti-aircraft (AA) machine gun	رشاش خفيف مضاد للطائرات
49 SF Lance missile launch system (missile launcher)	نظام إطلاق صواريخ "إس إف لانس"
50 skirt	وقاء
51 tracked vehicle	عربة مجنزرة
52 missile (guided missile)	صاروخ (صاروخ مُوجَّه)
53 elevating gear	ترس ضبط الارتفاع
54 launching ramp	بِنَصَة إطلاق
55 110 SF 2 rocket launcher	قاذف صواريخ طراز "110 إس إف 2"
56 fire control system	نظام ضبط النيران
57 launching tubes	مواسير الإطلاق
58 tube bins	صناديق المواسير
59 turntable	صينية دوّارة
60 jack	دعامة تثبيت رأسية
61 driver's cab	كابينة السائق
62-87 armoured (Am. armored) vehicles	عربات مدرعة
62 Leopard 2 tank	دبابية "ليوبارد 2"
63 smooth-barrelled gun	مدفع بماسورة لمساء
64 driver's hatch	حجيرة السائق
65 commander's periscope	بريسكوب القائد
66 smoke canister (smoke dispenser)	حاوية الدخان
67 Luchs armoured (Am. armored) reconnaissance vehicle, an amphibious vehicle	عربة استطلاع مدرعة طراز "لوكس"، عربة برمائية
68 cannon	مدفع
69 hatch	حجيرة
70 antenna	هوائي
71 propeller (for propulsion in water)	رفاص (للدفع في الماء)
72 Jagdpanzer Jaguar 1 ATGW vehicle (HOT)	عربة طراز "جاذبانزر جاجوار 1 إيه تي جي دبلير"
73 guidance system (upper part) with guidance unit	نظام توجيه (الجزء العلوي) وبه وحدة التوجيه
74 HOT guided-missile launcher	قاذف صواريخ "هوت"
75 firing mechanism (upper part)	آلية الإطلاق (الجزء العلوي)

76 commander's cupola	قبة القائد
77 Marder armoured (Am. armored) personnel carrier	ناقلة جنود مدرعة طراز "ماردر"
78 searchlight	ضوء كاشف
79 MILAN anti-tank guided-missile system	نظام "ميلان" للصواريخ الموجة المضادة للدبابات
80 Fuchs armoured (Am. armored) personnel and load carrier, an amphibious vehicle	ناقلة جنود وأحمال مدرعة طراز "فوكس"، عربة برمائية
81 rear door	باب خلفي
82 Gepard anti-aircraft tank	دبابية "جيبارد" مضادة للطائرات
83 surveillance radar	رادار مراقبة
84 tracking radar for fire control	رادار التتبع الخاص بضبط النيران
85 twin 35 mm cannon	مدفع مزدوج عيار 35 ملم
86 MI13 A1 G armoured personnel carrier	ناقلة جنود مدرعة طراز "إم 113 إيه 1"
87 machine gun on a traversing mount	مدفع رشاش على محمل التشتير
88-96 helicopters	طائرات الهليكوبتر
88 CH-53 G transport helicopter	طائرة هليكوبتر للنقل طراز "سي إتش 53"
89 single rotor	مروحة مفردة
90 turbine	توربين
91 stabilizing tail rotor	مروحة ذيل الموازنة
92 fuselage	بدن الطائرة
93 cockpit	كابينة الطائرة
94 BO-105P anti-tank helicopter	صاندة دبابات طراز "بي أو 105 بي"
95 skid	زلافة هبوط
96 HOT anti-tank guided-missile launcher	قاذف صواريخ "هوت" موجهة مضادة للدبابات

256 Armed Forces II (Air Force I)	القوات المسلّحة (2) (القوات الجوية (1))
1 McDonnell-Douglas F-4F Phantom II interceptor and fighter-bomber	طائرة متفوّضة ومقاتلة قاذفة تقابل طراز "ماكوبل-دوجلاس إف 4 إف فانتوم 2"
2 squadron marking	رمز السرب
3 aircraft cannon	مدفع الطائرة
4 wing tank (underwing tank)	مخزن ذخيرة الجناح (مخزن ذخيرة أسفل الجناح)
5 air intake	ممص هواء
6 boundary layer control flap	قلاية تحكم الطبقة المتاخمة
7 in-flight refuelling (Am. refueling) probe (flight refuelling probe, air refuelling probe)	وحدة التزود بالوقود في الجو
8 Panavia 2000 Tornado multirole combat aircraft (MRCA)	طائره قتالية طراز "بينافيا 2000 تورنادو" متعددة المهام
9 swing wing	جناح أرنجحي

10 radar nose (radome, radar dome)	مُدَمَّة رادارية (قبة رادارية)
11 pitot-static tube (pitot tube)	أُنْيُوب التّوجيّه والإرشاد
12 brake flap (air brake)	قلاية فرملة هوائية
13 afterburner exhaust nozzles of the engines	فوهات عادم المحركات
14 C160 Transall medium-range transport aircraft	طائرة نقل متوسطة المدى طراز "سي 160 ترنسال"
15 undercarriage housing (landing gear housing)	مَيَّيت عجلات الهبوط
16 propeller-turbine engine (turboprop engine)	مُحَرِّك توربيني الدفع
17 antenna	هوائي
18 Bell UH-ID Iroquois light transport and rescue helicopter	طائرة هليكوبتر للإفقاذ والنقل الخفيف طراز "بل يو إتش - أي دي إروكوا"
19 main rotor	المروحة الرئيسية
20 tail rotor	مروحة الذيل
21 landing skids	مزلقات الهبوط
22 stabilizing fins (stabilizing surfaces, stabilizers)	زعانف الموازنة الجانبية
23 tail skid	مزلقة الذيل
24 Dornier DO 28 D-2 Skyservant transport and communications aircraft	طائرة إتصالات ونقل طراز "دورنيير دو 28 دي أو سكاى سرفنت"
25 engine pod	مقر المحرك
26 main undercarriage unit (main landing gear unit)	وحدة آلية الهبوط الرئيسية
27 tail wheel	عجلة المؤخرة (عجلة الذيل)
28 sword antenna	هوائي سيفي

257 Armed Forces III (Air Force II)	القوات المسلّحة (3) (القوات الجوية (2))
1-41 Dornier-Dassault-Breguet Alpha Jet Franco-German jet trainer	طائرة تدريب ثقاتة طراز دورنيير-دو سولت - بريجيت ألفا جيت فرانكو - جرمان
1 pitot-static tube (pitot tube)	أُنْيُوب التّوجيّه والإرشاد (أُنْيُوب بيتوت)
2 oxygen tank	خزان الأوكسجين
3 forward-retracting nose wheel	عجلة المقدمة قابلة للطي
4 cockpit canopy (cockpit hood)	قبة كابينة الطيار
5 canopy jack	مرفأع القبة
6 pilot's seat (student pilot's seat), an ejector seat (ejection seat)	مَقْعِد الطيار، مَقْعِد قاذف
7 observer's seat (instructor's seat), an ejector seat (ejection seat)	مَقْعِد المراقب (مَقْعِد المُدرِّب)، مَقْعِد قاذف

8 control column (control stick)	عمسا التّكمك
9 thrust lever	عتلة الدفع
10 rudder pedals with brakes	دوأسات الدفة وبها المكابح
11 front avionics bay	خجيرة إلكترونيات الطيران الأمامية
12 air intake to the engine	مدخل الهواء إلى المحرك
13 boundary layer control flap	قلاية تحكم الطبقة المتاخمة
14 air intake duct	فتحة دخول الهواء (الممص)
15 turbine engine	مُحَرِّك توربيني
16 reservoir for the hydraulic system	خزان النظام الهيدرولي
17 battery housing	خجيرة البطاريات
18 rear avionics bay	خجيرة إلكترونيات الطيران الخلفية
19 baggage compartment	خجيرة الأمتعة
20 triple-spar tail construction	عُضُد الذيل الثلاثي
21 horizontal tail	ذيل أفقي
22 servo-actuating mechanism for the elevator	آلية تشغيل مؤازرة لجهاز الارتفاع
23 servo-actuating mechanism for the rudder	آلية تشغيل مؤازرة للدفة
24 brake chute housing (drag chute housing)	حجيرة مظلة الكبح
25 VHF (very high frequency) antenna (UHF antenna)	هوائي تردد عال جداً (هوائي تردد فائق العلو)
26 VOR (very high frequency omnidirectional range) antenna	هوائي لجميع الاتجاهات ذو تردد عال جداً
27 twin-spar wing construction	جناح ذو عُضُد ثنائي
28 former with integral spars	قلاط ذو أعضاد متكاملة
29 integral wing tanks	خزانات ثابتة بالجناح
30 centre-section (Am. center-section) fuel tank	خزان وقود بوسط الطائرة
31 fuselage tanks	خزانات جسم الطائرة
32 gravity fuelling (Am. fuelling) point	نقطة تزود بوقود الجاذبية
33 pressure fuelling (Am. fuelling) point	نقطة تزود بوقود الضغط
34 inner wing suspension	تعليق الجناح الداخلي
35 outer wing suspension	تعليق الجناح الخارجي
36 navigation lights (position lights)	أضواء الملاحة (أضواء توضع موقع الطائرة)
37 landing lights	أضواء الهبوط
38 landing flap	قلاية الهبوط
39 aileron actuator	مُشغّل الجنيح
40 forward-retracting main undercarriage unit (main landing gear unit)	وحدة آلية الهبوط الرئيسية
41 undercarriage hydraulic	الأسطوانة الهيدروليّة لآلية

عصا التّكمك	عمسا التّكمك
عتلة الدفع	عتلة الدفع
دوأسات الدفة وبها المكابح	دوأسات الدفة وبها المكابح
خجيرة إلكترونيات الطيران الأمامية	خجيرة إلكترونيات الطيران الأمامية
مدخل الهواء إلى المحرك	مدخل الهواء إلى المحرك
قلاية تحكم الطبقة المتاخمة	قلاية تحكم الطبقة المتاخمة
فتحة دخول الهواء (الممص)	فتحة دخول الهواء (الممص)
مُحَرِّك توربيني	مُحَرِّك توربيني
خزان النظام الهيدرولي	خزان النظام الهيدرولي
خجيرة البطاريات	خجيرة البطاريات
خجيرة إلكترونيات الطيران الخلفية	خجيرة إلكترونيات الطيران الخلفية
خجيرة الأمتعة	خجيرة الأمتعة
عُضُد الذيل الثلاثي	عُضُد الذيل الثلاثي
ذيل أفقي	ذيل أفقي
آلية تشغيل مؤازرة لجهاز الارتفاع	آلية تشغيل مؤازرة لجهاز الارتفاع
آلية تشغيل مؤازرة للدفة	آلية تشغيل مؤازرة للدفة
حجيرة مظلة الكبح	حجيرة مظلة الكبح
هوائي تردد عال جداً (هوائي تردد فائق العلو)	هوائي تردد عال جداً (هوائي تردد فائق العلو)
هوائي لجميع الاتجاهات ذو تردد عال جداً	هوائي لجميع الاتجاهات ذو تردد عال جداً
جناح ذو عُضُد ثنائي	جناح ذو عُضُد ثنائي
قلاط ذو أعضاد متكاملة	قلاط ذو أعضاد متكاملة
خزانات ثابتة بالجناح	خزانات ثابتة بالجناح
خزان وقود بوسط الطائرة	خزان وقود بوسط الطائرة
خزانات جسم الطائرة	خزانات جسم الطائرة
نقطة تزود بوقود الجاذبية	نقطة تزود بوقود الجاذبية
نقطة تزود بوقود الضغط	نقطة تزود بوقود الضغط
تعليق الجناح الداخلي	تعليق الجناح الداخلي
تعليق الجناح الخارجي	تعليق الجناح الخارجي
أضواء الملاحة (أضواء توضع موقع الطائرة)	أضواء الملاحة (أضواء توضع موقع الطائرة)
أضواء الهبوط	أضواء الهبوط
قلاية الهبوط	قلاية الهبوط
مُشغّل الجنيح	مُشغّل الجنيح
وحدة آلية الهبوط الرئيسية	وحدة آلية الهبوط الرئيسية
الأسطوانة الهيدروليّة لآلية	الأسطوانة الهيدروليّة لآلية

cylinder (landing gear hydraulic cylinder)	الهبوط	34 depth-charge thrower	قاذف قنابل الأعماق	73 40 mm anti-aircraft (AA) gun	مدفع عيار 40 ملم مضاد للطائرات	8 radar antenna (radar scanner)	هوائي راداري
258 Warships I	السفن الحربية (1)	35 weapon system radar	رادار نظام التسليم	74 propeller guard moulding (Am. molding)	قالب وقاء الرافاص	9 fully enclosed bow	جَوْجُو مغلَق بالكامل
1 Hamburg class guided-missile destroyer	مدمرة طراز "هامبورج" تحصل صواريخها موجهة	36 radar antenna (radar scamer)	جهاز تحديد المدى البصري مدمرة فئة "لوتشن" محملة بصواريخ موجهة	75 type 143 missile-firing fast attack craft	زورق صواريخ هجومي سريع فئة 143 حائل الأمواج	10 deck crane	مرقاغ السطح
2 hull of flush-deck vessel	بدن السفينة المستوية السطح	37 optical rangefinder	مرساة مقدم السفينة	76 breakwater (Am. manger board)	الرادوم (قبعة الرادار)	11 transom stern	كؤنل برافدة أفقية
3 bow (stem)	مقدم السفينة (الجؤجؤ)	38 Lütjens class guided-missile destroyer	وقاء الرافاص	77 radome (radar dome)	ماسورة الرادوم	12-20 deck plan	مخطط السطح
4 flagstaff (jackstaff)	صاري العلم (الراية)	39 bower anchor	صاري شبكي على حامل ثلاثي	78 torpedo tube	مسرب خروج العادم	12 angle deck (flight deck)	سطح زواوي (سطح الطيران)
5 anchor, a stockless anchor (patent anchor)	مرساة	40 propeller guard	عمود الصاري	79 exhaust escape flue	صاندة ألغام طراز 331	13 aircraft lift (Am. aircraft elevator)	مرفق الطائرات
6 anchor capstan (windlass)	رؤوية المرساة (مرقاغ المرساة)	41 tripod lattice mast	فتحات تهوية (شبكة التهوية)	80 type 331 mine hunter	أنواع احتكاك مقوأة	14 twin launching catapult	مجنقة مزدوجة
7 breakwater (Am. manger board)	حائل الأمواج	42 pole mast	ماسورة العادم	81 reinforced rubbing strake	قارب نفاحي	15 hinged (movable) baffle board	لوح حاجز مفصلي متحرك
8 chine strake	صفيفة ألواح ذات حافة	43 ventilator openings (ventilator grill)	قارب السفينة	82 inflatable boat (inflatable dinghy)	الداوودي	16 arrester wire	سلك كايح/موقف
9 main deck	السطح الرئيسي	44 exhaust pipe	هوائي	83 davit	كاسحة ألغام طراز 341	17 emergency crash barrier	حاجز ارتفاع للطوارئ
10-28 superstructures	أجزاء السفينة فوق السطح الرئيسي	45 ship's boat	مدفع بزجي لجميع الأغراض	84 type 341 minesweeper	مرقاغ كيبلي	18 safety net	شبكة أمان
11 superstructure deck	سطح التجهيزات العلوية	46 antenna	مدفع عيار 127 ملم لجميع الأغراض	85 cable winch	مرقاغ ماكينة السحب/القطر	19 caisson (cofferdam)	قيسون
12 life rafts	ألواح النجاة	47 radar-controlled 127 mm all-purpose gun in turret	قاذف صواريخ "تارتر"	86 towing winch (towing machine, towing engine)	جراحة الألغام (جهاز كسح الألغام)	20 eight-barrel anti-aircraft (AA) rocket launcher (missile launcher)	قاذف صواريخ مضادة للطائرات ثماني المواسير
13 cutter (ship's boat)	زورق سريع	48 127 mm all-purpose gun	هوائيات رادار ضبط الطيران	87 mine-sweeping gear (paravanes)	مرقاغ كيبلي (داوودي)	21 Kara class rocket cruiser (missile cruiser) (USSR)	زورق صواريخ فئة "كارا" (الاتحاد السوفيتي)
14 davit (boat-launching crane)	إنزال (وئش رفع أو إنزال قوارب النجاة)	49 launcher for Tartar missiles	قاذف صواريخ مضادة للفوآصات (أسروك)	88 crane (davit)	صندل إنزال فئة "يارب"	22 hull of flush-deck vessel	بدن سفينة سطح مستو
15 bridge (bridge superstructure)	منصة ريان السفينة (برج القيادة)	50 anti-submarine rocket (ASROC) launcher (missile launcher)	هوائيات رادار ضبط الطيران	89 Barbe class landing craft	سليم الإنزال الأمامي	23 sheer	مئذنة
16 side navigation light (side running light)	ضوء ملاحه جانبي	51 fire control radar antennas	الرادوم (قبعة الرادار)	90 bow ramp	سليم الإنزال الخلفي	24 twelve-barrel underwater salvo rocket launcher (missile launcher)	قاذف صليبات صواريخ تحت الماء ذو 12 ماسورة
17 antenna	هوائي	52 radome (radar dome)	فراقطة فئة "بريمن"	91 stern ramp	سفينة تموين صغيرة طراز "راين"	25 twin anti-aircraft (AA) rocket launcher (missile launcher)	قاذف صواريخ مضادة للطائرات مزدوج
18 radio direction finder (RDF) frame	محدد اتجاه اللاسلكي	53 Bremen class frigate	مدفع سريع الطيران عيار 76 ملم يتم التحكم فيه رادارياً	92 Rhein class tender	سفينة إسناد فئة "لونبيرج"	26 launching housing for 4 short-range rockets (missiles)	مبيت إطلاق أربعة صواريخ قصيرة المدى
19 lattice mast	صاري شبكي	54 radar-controlled 76 mm rapid-fire gun	صواريخ سطح- جو طراز "سي سبارو"	93 Lüneberg class support ship	ناقلة ألغام فئة "زاكسفالد"	27 twin anti-aircraft (AA) rocket launcher (missile launcher)	مبيت إطلاق أربعة صواريخ قصيرة المدى
20 forward funnel	مدخنة أمامية	55 Sea Sparrow surface-to-air missiles	نظام الرادار و ضبط الطيران	94 Sachsenwald class mine transport	سفينة قطر للإنقاذ طراز "هلجولاند"	28 launching housing for 4 short-range rockets (missiles)	مبيت إطلاق أربعة صواريخ قصيرة المدى
21 aft funnel	مدخنة خلفية	56 radar and fire control system	صواريخ سطح-سطح طراز "هاربون"	95 Helgoland class salvage tug	سفينة الإمداد بالمون والوقود "إيفيل"	29 radar antenna (radar scanner)	رادار
22 cowl	طربوش المدخنة	57 Harpoon surface-to-surface missiles	مدخنة	96 replenishing tanker "Eifel"	السفن الحربية (2) (السفن الحربية الحديثة)	30 twin 76 mm anti-aircraft (AA) gun turret	برج مدفع مزدوج مضاد للطائرات عيار 76 ملم
23 aft superstructure (poop)	أجزاء السفينة الخلفية فوق السطح الرئيسي	58 funnel	طربوش المدخنة	259 Warships II (Modern Fighting Ships)	حاملة الطائرات النووية "تيمز أي سي في إن 68" (الولايات المتحدة الأمريكية)	31 turret	برج
24 capstan	رؤوية	59 cowl	رادار تفقد جو/أرض	1 nuclear-powered aircraft carrier Nimitz ICVN 68 (USA)	مخطط الجسم	32 funnel	مدخنة
25 companion ladder (companionway, companion hatch)	سلم داخلي	60 air/surface search radar	زورق سريع	2-11 body plan	سطح الطيران	33 twin anti-aircraft (AA) rocket launcher (missile launcher)	قاذف صواريخ مضادة للطائرات مزدوج
26 ensign staff	صاري الراية	61 cutter	زورق سريع	2 flight deck	منصة الريان (برج القيادة)	34 automatic anti-aircraft (AA) gun	مدفع آلي مضاد للطائرات
27 stern, a transom stern	الكؤنل مؤخرة السفينة	62 close-range surface-to-air missiles	صواريخ سطح-جو للمدى القريب	3 island (bridge)	مرقاغ الطائرات	35 ship's boat	قارب السفينة
28 waterline	خط الماء	63 helicopter deck	سطح هبوط الهليكوبتر	4 aircraft lift (Am. aircraft elevator)	قاذف صواريخ مضادة للطائرات ثماني المواسير	36 underwater 5-torpedo housing	مبيت تحت الماء لعدد خمس قذائف طوربيد
29 searchlight	أنوار كاشفة	64 type 206 submarine	غواصة فئة 206	5 eight-barrel anti-aircraft (AA) rocket launcher (missile launcher)	قاذف صواريخ مضادة للطائرات ثماني المواسير	37 underwater 6-salvo rocket launcher (missile launcher)	قاذف صواريخ تحت الماء لعدد ست صليبات
29-37 armament	التسليح	65 flooded foredeck	سطح أمامي غاطس	6 pole mast (antenna mast)	عمود الصاري (صاري الهوائي)	38 helicopter hangar	حظيرة الهليكوبتر
29 100 mm gun turret	برج مدفع عيار 100 ملم	66 pressure hull	بدن يتحمل ضغط المياه	7 antenna	هوائي	39 helicopter landing platform	منصة هبوط الهليكوبتر
30 four-barrel anti-submarine rocket launcher (missile launcher)	قاذف صواريخ مضادة للفوآصات رباعي	67 turret	برج الغواصة				
31 40 mm twin anti-aircraft (AA) gun	مدفع مزدوج مضاد للطائرات عيار 40 ملم	68 retractable instruments	آلات قابلة للطي				
32 MM 38 anti-aircraft (AA) rocket launcher (missile launcher) in launching container	قاذف صواريخ إم إم 38 مضادة للطائرات في حبيزة الإطلاق	69 type 148 missile-firing fast attack craft	زورق صواريخ هجومي سريع فئة 148				
33 anti-submarine torpedo tube	ماسورة طوربيد مضاد للفوآصات	70 76 mm all-purpose gun with turret	مدفع عيار 76 ملم لكافة الأغراض محمول على برج حامل إطلاق الصواريخ				
		71 missile-launching housing	بيت سطح السفينة				
		72 deckhouse					

40 variable depth sonar (VDS)	سونار سَبْر الأعماق	[for torpedoes]	أُتْيُوب الطوربيد	24 pen and pencil tray	صينية الأَقلام الجبر والريصاصي	67-80 pupils' (children's) work	أشغال التلاميذ
41 California class rocket cruiser (missile cruiser) (USA)	زُورق صواريخ طراز "كالفورنيا" (الولايات المتحدة الأمريكية)	80 bow bilge	جَمَة الجَوَاحِزْ	25 desk mat (blotter)	نَشَافَة المَكْتَب	67 clay models (models)	نماذج من الصلصال
42 hull	بَدَن القارب	81 anchor	مِرساة	26 window painting with finger paints (finger painting)	طَبَلاء النافِذَة بأقلام مَلَوْنَة	68 window decoration of coloured (Am. colored) glass	زُخْرَفَة نافذة من الرِّجَاح المَكوَّن
43 forward turret	بَرْج أَمَامِي	82 anchor winch	وَشْش المِرساة	27 pupils' (children's) paintings (watercolours, Am. watercolors)	رسومات التلاميذ	69 glass mosaic picture (glass mosaic)	فَسْطِيسَاء زُجَاج
44 aft turret	بَرْج خَلْفِي	83 battery	بَطَّارِيَة	28 cross	صَلِيب	70 mobile	لُعْبَة تعلق
45 forward superstructure	أجزاء السفينة الأمامية	84 living quarters with folding bunks	عُنايِر معيشة بها أَسِرَة قابلة للطي	29 three-part blackboard	سَبُورَة ثَلَاثِيَّة	71 paper kite (kite)	طَائِرَة وَرَقِيَّة
46 landing craft	زُورق الإنزال	85 commanding officer's cabin	كاتبية ضابط القيادة	30 bracket for holding charts	كُتِفَة حَمَل الرِّسُوم البِيانِيَّة	72 wooden construction	بِناء خَشَبِي
47 antenna	هوائي	86 main hatchway	فَتْحَة أَرْضِيَّة القارب الرئيسيَّة	31 chalk ledge	حَافَة وَضَع الطباشير	73 polyhedron	مُجَسَّم مُعَدَد الأَسْطَاح
48 radar antenna (radar scanner)	هوائي راداري	87 flagstaff	عمود الراية	32 chalk	طباشير	74 hand puppets	ذُمِيَّات يدويَّة
49 radome (radar dome)	قبة رادارية	88-91 retractable instruments	مُعَدَّات قابلة للضم	33 blackboard drawing	رِسم على السَبُورَة	75 clay masks	أَقْعَة من الصلصال
50 surface-to-air rocket launcher (missile launcher)	قاذف صواريخ سطح-جوّ	88 attack periscope	بريسكوب الهجوم	34 diagram	رِسم تَخْطِيطِي	76 cast candles (wax candles)	شمعدان مصبوب
51 underwater rocket launcher (missile launcher)	قاذف صواريخ تحت الماء	89 antenna	هوائي	35 reversible side blackboard	رِسم سَبُورَة قَلَابَة	77 wood carving	نَحْت خَشَبِي
52 127 mm gun with turret	مِذْفَع بُرْجِي عيار 127 ملم	90 snorkel (schnorkel)	سَنُورَكَل	36 projection screen	شاشَة فانوس الإسقاط	78 clay jug	إبريق من الصلصال
53 helicopter landing platform	مِنصَّة هبوط الهليكوبتر	91 radar antenna (radar scanner)	هوائي رادار	37 triangle	مِثلَّث	79 geometrical shapes made of clay	أَشْكال هندسيَّة مصنوعة من الصلصال
54 nuclear-powered fleet submarine	غَوَاصَة أسطول نوويَّة	92 exhaust outlet	ماسورة خروج العادم	38 protractor	مِثْقَلَة	80 wooden toys	لُعْب خَشَبِيَّة
55-74 middle section [diagram]	القِسْم الأَوْسَط [رسم تخطيطي]	93 heat space (hot-pipe space)	مكان أُتْيُوب التدفئة	39 divisions	تَدْرِيج المِثْقَلَة	81 materials	مَوَاد
55 pressure hull	بَدَن يَحْمَل الضغط	94 diesel generators	مُولدات تعمل بالديزل	40 blackboard compass	فَرِجَار السَبُورَة	82 stock of wood	رِصَة أَخْشَاب
56 auxiliary engine room	غرفة المحرك المساعد	95 aft diving plane and vertical rudder	سَطْح الغُرُص الخلفي والذفة الرأسية	41 sponge tray	صِنِيَّة إسْفنجَة مِشَّح السَبُورَة	83 inks for wood cuts	جَبَر للمصنوعات الخشبية
57 rotary turbine pump	مِضْبِجَة توربينية دوَّارَة	96 forward vertical rudder	الذفة الرأسية الأمامية	42 blackboard sponge (sponge)	إِسْفنجَة مِشَّح السَبُورَة	84 paintbrushes	فُرُش الكُتُوب
58 steam turbine generator	مُولد توربيني بخاري			43 classroom cupboard	خزانة خِزْفَة الدِّرَاسَة	85 bag of plaster of Paris	جَوَال جِصن باريِس
59 propeller shaft	عمود الرِّفَاص	260 School I (Primary School)	المَدْرَسَة (I) (المَدْرَسَة الإِبْتِدَائِيَّة)	44 map (wall map)	خَرِيطَة (خَرِيطَة حائط)		
60 thrust block	كُتْلَة الدَّفْع	1-85 primary school	مَدْرَسَة إِبْتِدَائِيَّة	45 brick wall	حائط من قِوَاب الطُوب	1-45 grammar school;	مَدْرَسَة متوسِّطَة، مدرسة ثانوية
61 reduction gear	تروس تقليل السرعة	1-45 classroom	خِزْفَة الدِّرَاسَة	46 workbench	طاوِلة الشَّغَل	also: upper band of a comprehensive school (Am. alternative school)	
62 high and low pressure turbine	توربين ضغط عال ومنخفض	1 arrangement of desks in a horseshoe	ترتيب المقاعد على شكل خَدْوَة فرس	47 vice (Am. vise)	مِلمَزَة	1-13 chemistry	الكيمياء
63 high-pressure steam pipe for the secondary water circuit (auxiliary water circuit)	ماسورة بخار ضغط عال لدائرة الماء الثانوية	2 double desk	مُعدّد مزدوج	48 vice (Am. vise) bar	ذِرَاع المِلمَزَة	chemistry lab (chemistry laboratory) with tiered rows of seats	مَعْمَل الكيمياء مَجهَز بصفوف تصاعديَّة من المقاعد
64 condenser	مُكثِّف	3 pupils (children) in a group (sitting in a group)	تلاميذ يَجِلسون كجموعَة	49 scissors	مِقص	2 chemistry teacher	مُدْرَس الكيمياء
65 primary water circuit	دائرة الماء الرئيسية	4 exercise book	كتاب التمارين	50-52 working with glue (sticking paper, cardboard, etc.)	الشَّغَل بالصَّمغ	3 demonstration bench (teacher's bench)	طاوِلة الشُّروَح المعلميَّة
66 heat exchanger	مُبادِل حراري	5 pencil	قلم رصاص	50 surface to be glued	سَطْح سِمْح تصميغِه	4 water pipe	أُتْيُوب ماء
67 nuclear reactor casing (atomic pile casing)	غلاف مفاعل نووي	6 wax crayon	قلم الوَاق شَمَع	51 tube of glue	أُتْيُوب الصَّمغ	5 tiled working surface	سطح شغل مِبلَط
68 reactor core	قلب المفاعل النووي	7 school bag	حَقِيْبَة المَدْرَسَة	52 tube cap	عِطَاء الأُتْيُوب	6 sink	حَوْض
69 control rods	قضبان تحكّم	8 handle	يَد الحَقِيْبَة	53 fretsaw	مِشَّار زُخْرَفَة/ أَرْكَب	7 television monitor, a screen for educational programmes (Am. programs)	شاشَة عَرْض تِلْفِز يُونِيَّة، شاشَة عَرْض البرامِج التعليميَّة
70 lead screen	سِتَّار رصاص	9 school satchel (satchel)	حَقِيْبَة الكُتُب	54 fretsaw blade (saw blade)	مِشَّار زُخْرَفَة/ الأَرْكَب	8 overhead projector	بروجكتور الإسقاط الرأسي
71 turret	بَرْج	10 front pocket	جِيب أَمَامِي	55 wood rasp (rasp)	مِزْد الخَشَب	9 projector top for skins	السطح العلوي للبروجكتور المخصص لوضع الشرائح الشفافة
72 snorkel (schnorkel)	سَنُورَكَل	11 strap (shoulder strap)	حَزَام (حِزَام الكُتُب)	56 piece of wood held in the vice (Am. vise)	قِطْعَة خَشَب مِثْقَلَة بالمِلمَزَة	10 projection lens with right-angle mirror	عدسة إسقاط ذات مرآة قائمة الزاوية
73 air inlet	فَتْحَة دُخُول الهِواء	12 pen and pencil case	عِطْلَة	57 glue pot	قِنبِيَّة الصَّمغ	11 pupils' (Am. students') bench with experimental apparatus	دُكَة التلاميذ المزمودة بأجهزة التجارب
74 retractable instruments	مُعَدَّات قابلة للضم	13 zip (Am. zipper)	سَوَسَة	58 stool	كُرْسِي بدون سِنْد للظهُر	12 electrical point (socket)	مَقْبَس كهربائي
75 patrol submarine with conventional (diesel-electric) drive	غَوَاصَة دُورِيَّة بإدارة دَفْع تقليديَّة	14 fountain pen (pen)	قلم حبر سائل	59 brush	فُرْشَة	13 projection table	مُضَد الإسقاط
76 pressure hull	بَدَن يَحْمَل الضغط	15 loose-leaf file (ring file)	قلم حبر بَحْفَة	60 pan (dustpan)	صَفِيْحَة الغَافِيات		
77 flooded foredeck	سطح أمامي غاطس	16 reader	كِتاب تَعلِيم القِراءة	61 broken china	قِطْع خَزَف مَكْشُورَة		
78 outer flap (outer doors)	أبواب خارجيَّة [للطوربيد]	17 spelling book	كِتاب تَعلِيم الكِتابَة	62 enamelling (Am. enameling)	الطَلاء بالمِينا		
		18 exercise book (note-book)	كِتاب التمارين	63 electric enamelling (Am. enameling) stove	فَرْن الطَلاء بالمِينا الكهربِي		
		19 felt tip pen	قلم مَرَمَق من اللِباد	64 unworked copper	نحاس لم يَشْكَل بَعْد		
		20 pupil raising her hand	تلميذة ترفع يدها	65 enamel powder	مسحوق المِينا		
		21 teacher	مُدْرَس	66 hair sieve	مُخْتَل شَعْرِي		
		22 teacher's desk	مَكْتَب المُدْرَس				
		23 register	سِجَل، دَفْتر				

مكافحة الشغب
عربة عمليات خاصة مدرّعة

ساتر، حاجز

رجل شرطة مجهز بعتاد

مكافحة الشغب
هراوة

درع مكافحة الشغب

خوذة واقية

مسدس الخدمة (مسدس

ميري)

قبضة المسدس

جراب سول الفتح لسحب

السلاح بسرعة

مخزن الذخيرة

شاردة هوية الشرطة

المعدنية

شاردة الشرطة

التعرف على بصمات

الأصابع

بصمة اصبع

شاشة ضوئية

التفتيش

مشتبه فيه، مشوه

رجل شرطة سري (رجل

شرطة يرتدي ملابس

عادية)

رجل شرطة إنجليزي

خوذة

دفتر المخالفات

شرطة

عربة الشرطة

المقهى

مقهى، بالمثل صالة

الشاى، صالة الشروبات

كاونتر الكعك

غلاية إعداد القهوة

صينية الفود

جاتوه

حلوى المرنج وعليها كريمة

مخفوقة

حلواني تحت التدريب

مُصيفة الكاونتر

أرفف الجرائد

مصباح جداري

مقعد الزاوية، مقعد منجد

طاولة المقهى

سطح رخامي

نادلة، جرسونة، مضيئة

مسيبة

زجاجة عصير الليمون

كوب عصير الليمون

لاعيان يلعبان مباراة

المحدث الانتخابي

مثير الخطاب

ميكروفون

جمهور الحاضرين

رجل يقوم بتوزيع

منشورات

المضيفون

شريط الذراع

لافتة بأحرف ضخمة

إعلان

بيان

شخص يقاطع المتحدث

بكثرة أسلته

الانتخاب

مقر انتخابي

مستولا الانتخاب

قائمة انتخابية

بطاقة انتخابية ذات رقم

انتخابي

ورقة انتخابية تحمل أسماء

الأحزاب والمرشحين

مظروف الاقتراع

مضوت، ناخب

خبيزة الانتخاب

ناخب (مضوت مؤهل)

لوائح العملية الانتخابية

سجل انتخابي

شرف الانتخابات

صندوق الاقتراع

فتحة الصندوق

الشرطة

مهام الشرطة

طائرة هليكوبتر تابعة

للشرطة لتنظيم حركة

المرور من الجو

كابينة قيادة الطائرة

مروحة (المروحة الرئيسية)

مروحة الذيل

استخدام الكلاب البوليسية

كلب بوليسي

زي رسمي

قبعة الزي الرسمي

تنظيم المرور بواسطة

دورية مرور متحركة،

سيارة الدورية

مصباح أزرق

مكبر صوت

تنظيم المرور بواسطة

دورية مرور متحركة،

سيارة الدورية

مصباح أزرق

مكبر صوت

تنظيم المرور بواسطة

دورية مرور متحركة،

سيارة الدورية

مصباح أزرق

مكبر صوت

تنظيم المرور بواسطة

دورية مرور متحركة،

سيارة الدورية

مصباح أزرق

مكبر صوت

تنظيم المرور بواسطة

دورية مرور متحركة،

سيارة الدورية

مصباح أزرق

مكبر صوت

تنظيم المرور بواسطة

دورية مرور متحركة،

سيارة الدورية

مصباح أزرق

مكبر صوت

تنظيم المرور بواسطة

دورية مرور متحركة،

سيارة الدورية

مصباح أزرق

مكبر صوت

تنظيم المرور بواسطة

دورية مرور متحركة،

سيارة الدورية

مصباح أزرق

مكبر صوت

تنظيم المرور بواسطة

دورية مرور متحركة،

سيارة الدورية

مصباح أزرق

مكبر صوت

تنظيم المرور بواسطة

دورية مرور متحركة،

سيارة الدورية

مصباح أزرق

مكبر صوت

تنظيم المرور بواسطة

دورية مرور متحركة،

سيارة الدورية

مصباح أزرق

مكبر صوت

تنظيم المرور بواسطة

دورية مرور متحركة،

سيارة الدورية

مصباح أزرق

مكبر صوت

تنظيم المرور بواسطة

دورية مرور متحركة،

سيارة الدورية

مصباح أزرق

مكبر صوت

تنظيم المرور بواسطة

دورية مرور متحركة،

سيارة الدورية

مصباح أزرق

مكبر صوت

تنظيم المرور بواسطة

دورية مرور متحركة،

سيارة الدورية

مصباح أزرق

مكبر صوت

تنظيم المرور بواسطة

دورية مرور متحركة،

سيارة الدورية

مصباح أزرق

مكبر صوت

تنظيم المرور بواسطة

دورية مرور متحركة،

سيارة الدورية

مصباح أزرق

مكبر صوت

تنظيم المرور بواسطة

دورية مرور متحركة،

سيارة الدورية

مصباح أزرق

مكبر صوت

تنظيم المرور بواسطة

دورية مرور متحركة،

سيارة الدورية

مصباح أزرق

مكبر صوت

تنظيم المرور بواسطة

دورية مرور متحركة،

سيارة الدورية

مصباح أزرق

مكبر صوت

تنظيم المرور بواسطة

دورية مرور متحركة،

سيارة الدورية

مصباح أزرق

مكبر صوت

تنظيم المرور بواسطة

دورية مرور متحركة،

سيارة الدورية

مصباح أزرق

مكبر صوت

تنظيم المرور بواسطة

دورية مرور متحركة،

سيارة الدورية

مصباح أزرق

مكبر صوت

تنظيم المرور بواسطة

دورية مرور متحركة،

سيارة الدورية

مصباح أزرق

مكبر صوت

تنظيم المرور بواسطة

دورية مرور متحركة،

سيارة الدورية

مصباح أزرق

مكبر صوت

تنظيم المرور بواسطة

دورية مرور متحركة،

سيارة الدورية

مصباح أزرق

مكبر صوت

تنظيم المرور بواسطة

دورية مرور متحركة،

سيارة الدورية

مصباح أزرق

مكبر صوت

تنظيم المرور بواسطة

دورية مرور متحركة،

سيارة الدورية

مصباح أزرق

مكبر صوت

تنظيم المرور بواسطة

دورية مرور متحركة،

سيارة الدورية

مصباح أزرق

مكبر صوت

تنظيم المرور بواسطة

دورية مرور متحركة،

سيارة الدورية

مصباح أزرق

مكبر صوت

تنظيم المرور بواسطة

دورية مرور متحركة،

سيارة الدورية

مصباح أزرق

مكبر صوت

تنظيم المرور بواسطة

دورية مرور متحركة،

سيارة الدورية

مصباح أزرق

مكبر صوت

تنظيم المرور بواسطة

دورية مرور متحركة،

سيارة الدورية

مصباح أزرق

مكبر صوت

تنظيم المرور بواسطة

دورية مرور متحركة،

سيارة الدورية

مصباح أزرق

مكبر صوت

تنظيم المرور بواسطة

دورية مرور متحركة،

سيارة الدورية

مصباح أزرق

مكبر صوت

تنظيم المرور بواسطة

دورية مرور متحركة،

سيارة الدورية

مصباح أزرق

مكبر صوت

تنظيم المرور بواسطة

دورية مرور متحركة،

سيارة الدورية

مصباح أزرق

مكبر صوت

تنظيم المرور بواسطة

دورية مرور متحركة،

سيارة الدورية

مصباح أزرق

مكبر صوت

تنظيم المرور بواسطة

دورية مرور متحركة،

سيارة الدورية

مصباح أزرق

مكبر صوت

تنظيم المرور بواسطة

دورية مرور متحركة،

سيارة الدورية

مصباح أزرق

مكبر صوت

تنظيم المرور بواسطة

دورية مرور متحركة،

سيارة الدورية

مصباح أزرق

مكبر صوت

تنظيم المرور بواسطة

دورية مرور متحركة،

سيارة الدورية

مصباح أزرق

مكبر صوت

تنظيم المرور بواسطة

دورية مرور متحركة،

سيارة الدورية

مصباح أزرق

مكبر صوت

تنظيم المرور بواسطة

دورية مرور متحركة،

سيارة الدورية

مصباح أزرق

مكبر صوت

تنظيم المرور بواسطة

دورية مرور متحركة،

سيارة الدورية

مصباح أزرق

مكبر صوت

تنظيم المرور بواسطة

دورية مرور متحركة،

سيارة الدورية

مصباح أزرق

مكبر صوت

تنظيم المرور بواسطة

دورية مرور متحركة،

سيارة الدورية

مصباح أزرق

مكبر صوت

تنظيم المرور بواسطة

دورية مرور متحركة،

سيارة الدورية

مصباح أزرق

مكبر صوت

تنظيم المرور بواسطة

دورية مرور متحركة،

سيارة الدورية

مصباح أزرق

مكبر صوت

تنظيم المرور بواسطة

دورية مرور متحركة،

سيارة الدورية

مُحاضر (المدرّس
الجامعي)

36 flower stand حامل الزهور
37 flower arrangement باقة زهور
38 double bed سرير مزدوج لغرفتين
39 function room (banqueting hall) صالة المأدبات/المناسبات

حفلة خاصة

40 speaker proposing a toast متحدث يقترح نخباً
41 42's neighbour (Am. neighbor) الجالس جوار رقم 42

42 43's partner رفيق الجالس رقم 43
43 42's partner رفيقة الجالس رقم 42

44 bar trio ثلاثي عازفي البار
45 violinist عازف الكمان
46 couple dancing شاب وفتاة يرقصان (dancing couple)

47 waiter الخادِم، الجرسون

48 napkin منشفة ورقية

49 cigarette سيجارة

50 ashtray مِغْفَضَةُ السجائر

51 hotel bar بار الفندق

52 foot rail مسند القدم

53 bar stool كرسي البار

54 bar بار

55 bar customer زبون البار

56 cocktail glass (Am. highball glass) كأس الكوكتيل

57 whisky (whiskey) glass كأس الويسكي

58 champagne cork قنبلة زجاجة الشمبانيا

59 champagne bucket دلو تبريد زجاجة الشمبانيا (champagne cooler)

60 measuring beaker (measure) إناء قياس حجم المتروب (عبارة)

61 cocktail shaker زجاجة الكوكتيل

62 bartender (barman, Am. barkeeper, barkeep) الساقِي

63 barmaid الساقية

64 shelf for bottles رفّ زجاجات

65 shelf for glasses رفّ الكؤوس

66 mirrored panel لوح زجاجي عاكس

67 ice bucket دلو الثلج

68 hotel foyer رواق الفندق

المدينة (وسط المدينة)

عداد انتظار السيارات

خريطة المدينة (خريطة الشوارع)

لوحة ضوئية

مفتاح زر صندوق المهملات

فانوس الشارع

لافتة اسم الشارع

بالوعة

متجر/محل ملابس (دار

77 salt cellar and pepper pot المَلَاة ووعاء الفلفل

78 table decoration زينة المائدة (باقة أزهار)

267 Hotel

1-26 vestibule (foyer, reception hall) الفُندق

1 doorman رَهْمَة (صالة، قاعة استقبال)

(commissionaire) بواب

2 letter rack with pigeon holes رفّ الخطابات وبه صناديق حفظ البريد

3 key rack لَوْحَة مفاتيح الغُرفة

4 globe lamp, a frosted glass globe مصباح كروي، مصباح كروي مصفر

5 indicator board لَوْحَة إرشادية

6 indicator light ضوء إرشادي

7 chief receptionist رئيس موظفي الاستقبال

8 register (hotel register) السجِّل (مسجِّل الفندق)

9 room key مفتاح غُرفة

10 number tag (number tab) showing room number بطاقة رقم الغُرفة

11 hotel bill فاتورة الفندق

12 block of registration forms مجموعة من نماذج تسجيل الأضياء

13 passport جواز سفر

14 hotel guest نزيل بالفندق

15 lightweight suitcase [for air travel] حقيبة ملابس خفيفة

16 wall desk مَكْتَبٌ مُنْتَبِط بالجدار

17 porter (Am. baggage man) سَيَّال، حَمَّال

18-26 lobby (hotel lobby) بهو الفندق

18 page (pageboy, Am. bell boy) وصيف (خادم يرتدي بزة خاصة)

19 hotel manager مَدِير الفندق

20 dining room (hotel restaurant) قاعة تناول الطعام (مَطْعَم الفندق)

21 chandelier ثُرَيَّا (تِجْفَة)

22 fireside جانب المدفأة/المستوقد

23 fireplace المدفأة، المُسْتَوْقَد

24 mantelpiece (mantelshelf) رفّ المدفأة/المستوقد

25 fire نار

26 armchair كرسيّ ذو مسند للذراع

27-38 hotel room, a double room with bath غُرفة الفندق، غُرفة مزدوجة بحمام

27 double door باب مزدوج

28 service bell panel لَوْحَة جرس استدعاء موظف خدمة الغُرفة

صَوَان المِلابس

29 wardrobe (Am. clothes closet) خِلفَة المِلابس

30 clothes compartment خِلفَة المفروشات

31 linen compartment حَوْض غسيل مزدوج

32 double washbasin مُصْبِف خدمة الغُرفة

33 room waiter تليفون الغُرفة

34 room telephone سِباط/سجادة مضمّلية

35 velour (velours) carpet

game of chess شطرنج
18 coffee set طاقم القهوة
19 cup of coffee فنجان القهوة
20 small sugar bowl سكرية صغيرة
21 cream jug (Am. creamer) إناء مبيض القهوة

22-24 café customers زبائن المقهى

22 gentleman رجل

23 lady سيدة

24 man reading a newspaper رجل يقرأ جريدة

25 newspaper جريدة

26 newspaper holder حامل الجريدة

27 espresso قهوة أكسسو

28 ice cream in assorted flavours (Am. flavors) آيس كريم مُشكَل

29 ice-cream dish (sundae dish) طبق الآيس كريم (مطبق آيس كريم صُنْدَاي)

30 iced coffee قهوة مُثلّجة

31 (drinking) straw شاروقة

266 Restaurant

1-27 restaurant المطعم

1-11 bar (counter) البار (الكاونتر)

1 beer pump (beerpull) ماكينة صب البعة

2 drip tray صينية تصريف القطرات

3 beer glass المتساقطة

4 froth (head) كُوب البِجَة

5 spherical ashtray for cigarette and cigar ash رفّوة البِجَة

6 beer glass (beer mug) مِغْفَضَةُ السجائر والسِجَار كروية الشكل

7 beer warmer كُوب البِجَة (كُوز البِجَة)

8 bartender (barman, Am. barkeeper, barkeep) سِخّ تدفئة البِجَة الساقِي

9 shelf for glasses رفّ الأكواب

10 shelf for bottles رفّ اللّجّاجات

11 stack of plates رفّعة من الأطباق

12 coat stand حامل المعاطف (شماعة رأسية)

13 hat peg شمّاعة القبعات

14 coat hook خطّاف تعليق المِغْفَط

15 wall ventilator مرؤحة تهوية مثبتة بالجدار

16 bottle زجاجة، قنبلة

17 complete meal وِجْبَة كاملة

18 waitress مضيّفة، نادبة، جرسونة

19 tray صينية

20 dessert, a slice of cake حلوى، شطيرة كيك

21 menu (menu card) قائمة الطعام

22 cruet stand حامل إبريق الزيت/الخلّ

23 toothpick holder حامل خلال الأسنان

24 matchbox holder حامل الكبريت/أعواد النُقاب

25 customer زبون

26 beer mat مفرش كوب البِجَة

27 meal of the day طبق اليوم

28-44 wine restaurant (wine bar) بار الخُضُور

28 tablecloth مفرش الطاولة

29 glass of water كُوب ماء

30 wine waiter, a head نايل تقديم الخُمور

waiter

31 wine list قائمة الخُمور

32 wine carafe دَبُورَق الخُمور

33 wineglass كأس الخُمور

34 tiled stove موقد قرميدي

35 stove tile قرميذة الموقد

36 stove bench أريكة الموقد

37 wooden panelling (Am. paneling) كسوة جدار خشبية

38 corner seat مَعْد الزاوية

39 table reserved for regular customers طاولة محجوزة للزبائن الدائمين

40 regular customer زبون دائم

41 cutlery chest صِوَان قَضِيَة (أدوات المائدة)

42 wine cooler مبرّد الخُمور

43 bottle of wine زجاجة خُمور

44 ice cubes (ice, lumps of ice) مكعبات الثلج

مَطْعَم الخدمة الذاتية

45-78 self-service restaurant رفّعة من الصواني

45 stack of trays الشاروقات، مصاصات

46 drinking straws (straws) مشابف ورقية

47 serviettes (napkins) حوامل قضيّة المائدة

48 cutlery holders رفّ الأطعمّة الباردة

49 cool shelf شريحة من كُوز الصّلص

50 slice of honeydew melon طبق سلطة

51 plate of salad طبق جبن

52 plate of cheeses طبق سمك

53 fish dish لفائف

54 filled roll طبق لحوم والطعام

55 meat dish with trimmings المصاحب لها

56 half chicken نصف نِجاجة

57 basket of fruit سلّة فواكه

58 fruit juice عصير فواكه

59 drinks shelf رفّ المشروبات

60 bottle of milk زجاجة لبّ

61 bottle of mineral water زجاجة مياه معدنية

62 vegetarian meal (diet meal) وِجْبَة نباتية

63 tray صينية

64 tray counter طاولة الصواني

65 food price list قائمة أسعار الطعام

66 serving hatch بوابة الخدمة

67 hot meal وِجْبَة ساخنة

68 beer pump (beerpull) ماكينة صب البِجَة

69 cash desk مَكْتَب دفع النقديّة

70 cashier أمين الصندوق

71 proprietor مالك المطعم

72 rail درابزين، حاجز

73 dining area منطقة تناول الطعام

74 table طاولة، مائدة

75 open sandwich شطيرة

76 ice-cream sundae آيس كريم صاندي

house)	أزياء)	furniture truck)	كوبري عبور المشاة	6 pump strainer with foot valve	مثفل مضمخة ذو صمام سفلي	49 delivery pipe	أنبوب توصيل
10 shop window	واجهة المحل، فترتية	48 flyover	مصباح معلق لإتارة الشارع	7 bucket pump with motor	مضمخة دلوية ذات مخرّك	50 compressed-air vessel (air vessel, air receiver)	وعاء هواء مضغوط
11 window display (shop window display)	معروضات الفترتية	49 suspended street lamp	خط وقوف العربات لعبور المشاة	8 vacuum pump with motor	مضمخة خوائية بمحرّك	51 manhole	فتحة دخول
12 window decoration (shop window decoration)	ديكور الفترتية	50 stop line	عبور المشاة	9 rapid-filter plant	وحدة ترشيح سريع	52 delivery pipe	أنبوب توصيل
13 entrance	مدخل	51 pedestrian crossing (Am. crosswalk)	أضواء إشارة المرور	10 filter gravel (filter bed)	قاع الترشيح (طبقة ترشيح)	53 water meter, a rotary meter	عداد الماء
14 window	نافذة	52 traffic lights	عمود إشارة المرور	11 filter bottom, a grid	مخرّج الماء المرشح	54 water inlet	مدخل الماء
15 window box	أصيص النافذة	53 traffic light post	مجموعة الأضواء	12 filtered water outlet	خزان ماء تقني	55 counter gear assembly	مجموعة تروس العنّاد
16 neon sign	لافتة نيون	54 set of lights	أضواء عبور المشاة	13 purified water tank	أنبوب ماص ذو مصفاة	56 cover with glass lid	غطاء ذو سطح زجاجي
17 tailor's workshop	مُغزل الخياط	55 pedestrian lights	كُتْك التليفون	14 suction pipe with pump strainer and foot valve	ترشيح مضمخية وصمام سفلي	57 water outlet	مخرّج الماء
18 pedestrian	أحد المارة	56 telephone box (telephone booth, telephone kiosk, call box)	إعلان عن فيلم سينمائي	15 main pump with motor	مضمخة رئيسية بمحرك	58 water-meter dial	قرص عداد الماء
19 shopping bag	حقيرة الشئوق	57 cinema (Am. movie)	منطقة ترّجل المشاة (منطقة معبّدة)	16 delivery pipe	أنبوب توصيل الماء	59 counters	عدادات
20 road sweeper (Am. street sweeper)	كنّاس الشارع	58 pedestrian precinct (paved zone)	منطقة جالسة إلى طّاولة	17 compressed-air vessel (air vessel, air receiver)	وعاء هواء مضغوط	60 driven well (tube well, drive well)	بئر مغلقة/أنبوبية
21 broom	مكشّنة	59 street café	ظلة، تende	18 water tower	برج الماء	61 pile shoe	كعب الخازوق
22 rubbish (litter)	نفايات (مهملات)	60 group seated (sitting) at a table	سلم يؤدي إلى المراحيض العامة	19 riser pipe (riser)	أنبوب قائم (أنبوب عمودي)	62 filter	مُرشّح
23 tramlines (Am. streetcar tracks)	قضبان الترام (سكة الترام)	61 sunshade	موقف سيارات الأجرة	20 overflow pipe	أنبوب الفائض	63 water table (ground-water level)	مستوى الماء الباطني (منسوب الماء الجوفي)
24 pedestrian crossing (zebra crossing, Am. crosswalk)	عبور المشاة	62 steps to the public lavatories (public conveniences)	سيارة أجرة	21 outlet	مخرّج	64 well casing	قميص البئر
25 tram stop (Am. streetcar stop, trolley stop)	محطة الترام (محطة الترولي)	63 taxi rank (taxi stand)	سيارة أجرة	22 distribution main	ماسورة التوزيع الرئيسية	65 well head	رأس البئر
26 tram stop sign (Am. streetcar stop sign, trolley stop sign)	لافتة محطة الترام	64 taxi (taxicab, cab)	علامة سيارة الأجرة	23 excess water conduit	مجرى الماء الزائد	66 hand pump	مضمخة يدوية
27 tram timetable (Am. streetcar schedule, trolley schedule)	جدول بمواعيد الترام	65 taxi sign	لافتة تحمل عبارة "موقف سيارات أجرة"	24-39 tapping a spring	سحب المياه		
28 ticket machine	ماكينة التذاكر	66 'taxi rank' ('taxi stand') sign	تليفون استدعاء سيارة أجرة	24 chamber	غرفة		
29 'pedestrian crossing' sign	لافتة "عبور المشاة"	67 taxi telephone	مكتب البريد	25 chamber wall	جدار الغرفة		
30 traffic policeman on traffic duty (point duty)	رجل المرور أثناء المناوبة	68 post office	ماكينة بيع السجائر	26 manhole	فتحة دخول		
31 traffic control cuff	كمّ المرور (كمّ خاص يرتديه رجل المرور)	69 cigarette machine	عمود لصق الإعلانات	27 ventilator	فتحة تهوية		
		70 advertising pillar	إعلان (بوستر)	28 step irons	قضبان حديدية درّجية		
32 white cap	كاب أبيض	71 poster (advertisement)	خط أبيض	29 filling (backing)	حشو		
33 hand signal	إشارة يدوية	72 white line	سهم الإشارة للاعتفاف	30 outlet control valve	صمام التحكم في خروج الماء		
34 motorcyclist	راكب دراجة نارية	73 lane arrow for turning left	يساراً من الحارة	31 outlet valve	صمام خروج الماء		
35 motorcycle	دراجة نارية	74 lane arrow for going straight ahead	سهم الإشارة لمواصلة السير في خط مستقيم	32 strainer	مثفل		
36 pillion passenger (pillion rider)	راكب على المقعد الخلفي للدراجة	75 news vendor (Am. news dealer)	بائع الصحف	33 overflow pipe (overflow)	أنبوب الفائض		
37 bookshop	مكتبة			34 bottom outlet	فتحة خروج سفلية		
38 hat shop (hatter's shop); for ladies' hats: milliner's shop	محل القبعات؛ للسيدات محل بائعة القبعات النسائية			35 earthenware pipes	أنابيب من الفخار		
39 shop sign	لافتة المحل			36 impervious stratum (impermeable stratum)	طبقة غير منقّبة (طبقة كثيفة)		
40 insurance company office	مكتب شركة تأمين			37 rough rubble	حصي خشن		
41 department store	متجر ذو أقسام متنوّعة			38 water-bearing stratum (aquifer, aquafer)	طبقة حاملة للماء (طبقة خازنة للماء)		
42 shop front	الواجهة الأمامية للمحل			39 loam seal (clay seal)	طبقة لومية مانعة للتسرب		
43 advertisement	إعلان			40-52 individual water supply	إمداد المياه للأفراد		
44 flags	رايات			40 well	بئر		
45 illuminated letters	حروف ضوئية			41 suction pipe	أنبوب شفط		
46 tram (Am. streetcar, trolley)	ترام (ترولي)			42 water table (ground-water level)	مستوى الماء الباطني (منسوب الماء الجوفي)		
47 furniture lorry (Am. street sweeper)	شاحنة نقل الأثاث			43 pump strainer with foot valve	مثفل مضمخة ذو صمام سفلي		
				44 centrifugal pump	مضمخة طرد مركزي		
				45 motor	موتور		
				46 motor safety switch	مفتاح أمان الموتور		
				47 manostat, a switching device	مانوستات، جهاز تشغيل		
				48 stop valve	مخمس		

(French Baroque garden), palace gardens

1 grotto (cavern)

مغارة كهف طبيعي أو صناعي
تمثال حجري على شكل حورية الماء

2 stone statue, a river nymph

ذئبية البرتقال بيت زجاجي لزراعة البرتقال في المناطق الباردة

3 orangery (orangerie)

4 bosage (boskage)

متانة (متانة من الممرات والسيجات)

5 maze (labyrinth of paths and hedges)

6 open-air theatre (Am. theater)

مسرح مكشوف

7 Baroque palace

قصر باروكي نافورات

8 fountains

9 cascade (broken artificial waterfall, artificial falls)

شلال (مسقط مياه صناعي)

10 statue, a monument

تمثال قاعدة التمثال

11 pedestal

شجرة مثلمة بشكل كروي

12 globe-shaped tree

شجرة مثلمة بشكل مخروطي

13 conical tree

شجيرة زينة

14 ornamental shrub

نافورة جدارية

15 wall fountain

أريكة الحدائق

16 park bench

تعرّيشة، تكعيبة

17 pergola (bower, arbour, Am. arbor)

ممر من الحصى

18 gravel path (gravel walk)

شجرة هرمية الشكل

19 pyramid tree (pyramidal tree)

تمثال كوبيد (إله الحب)

20 cupid (cherub, amoretto, amorino)

نافورة

21 fountain

نفت من الماء

22 fountain

خوض الماء الفائض

23 overflow basin

خوض حافة نافذة

24 basin

شخص خرج للرجل

25 kerb (curb)

متردد سياحي

26 man out for a walk

مجموعة من السياح

27 tourist guide

تعليمات الحديقة

28 group of tourists

حارس الحديقة

29 park by-laws (bye-laws)

بوابات الحديقة مصنوعة من الحديد المطاوع

30 park keeper

مدخل الحديقة

31 garden gates made of wrought iron

سور الحديقة

32 park entrance

قضبان

33 park railings

صحن

34 railing (bar)

زهريّة حجريّة

35 stone vase

أرض عشبية

36 lawn

حد، سياج شجريّ شذب

37 border, a trimmed (clipped) hedge

مثنى الحديقة

38 park path

أرض مثشبة بها أحواض للزهور

39 parterre

شجرة البتولا أو السنذر

40 birch (birch tree)

حديقة على الطراز الإنجليزي

41-72 landscaped park (jardin anglais)

18 jumping sheet (sheet)

شبكة القفز

19 ambulance car (ambulance)

عربة الإسعاف

20 resuscitator (resuscitation equipment), oxygen apparatus

جهاز إنعاش القلب والرتنّين، جهاز أكسجين

21 ambulance attendant (ambulance man)

رجل الإسعاف

22 armband (armlet, brassard)

شريط/شارة الذراع

23 stretcher

نقالة

24 unconscious man

شخص فاقد الوعي

25 pit hydrant

حنفية حريق داخل حفرة

26 standpipe (riser, vertical pipe)

أنبوب قائم

27 hydrant key

مفتاح حنفية الحريق

28 hose reel (Am. hose cart, hose wagon, hose truck, hose carriage)

بكرة خرطوم الحريق (عربة خرطوم الحريق)

29 hose coupling

مقرن الخرطوم

30 soft suction hose

خرطوم طري ماص

31 delivery hose

خرطوم دقيق الماء

32 dividing breeching

طوق توزيع

33 branch

مسدس خرطوم الإطفاء

34 branchmen

رجلا مسدس خرطوم الإطفاء

35 surface hydrant (fire plug)

حنفية حريق فوق سطح الأرض

36 officer in charge

الضابط المسؤول

37 fireman (Am. firefighter)

رجل إطفاء، إطفائي

38 helmet (fireman's helmet, Am. fire hat) with neck guard (neck flap)

خوذة (خوذة الإطفائي) مزودة بواق الرقبة

39 breathing apparatus

جهاز التنفس

40 face mask

قناع واق، كمامة

41 walkie-talkie set

جهاز اتصال لاسلكي

42 hand lamp

صباح يدوي

43 small axe (Am. ax, pompiier hatchet)

بلمة صغيرة

44 hoot belt

حزام خطافي

45 belltine

حبل الحزام

46 protective clothing of asbestos (asbestos suit) or of metallic fabric

لباس واق مصنوع من مادة الأسبستوس أو نسج معدني

47 breakdown lorry (Am. crane truck, wrecking crane)

شاحنة وشنيّة

48 lifting crane

ونش رافع

49 load hook (draw hook, Am. drag hook)

خُصّاف الأحمال

50 support roll

أسطوانة تثبيت

51 water tender

عربة المياه

52 portable pump

مضخة محمولة

53 hose layer

عربة الخراطيم

54 flaked lengths of hose

أطوال من الخراطيم مكسوة برقائق

55 cable drum

أسطوانة الكيبل

56 winch

ونش

57 face mask filter

مرشح الكمامة/قناع الوجه

58 active carbon (activated carbon, activated charcoal)

كربون نشط (كربون منشط)

59 dust filter

مرشح الغبار

60 air inlet

مدخل الهواء

61 portable fire extinguisher

طفاية حريق محمولة

62 operating valve

صمام التشغيل

63 hose with spray nozzle

خرطوم ذو فوهة رش

64 foam-making branch (Am. foam gun)

مسدس الرغوة

65 fireboat

قارب إطفاء

66 monitor (water cannon)

مدفع الماء

67 suction hose

خرطوم شفط

271 Department Store

المُخْتَرَج التَّوْبَعِي

1 cashier

أمين الصندوق

2 electronic cash register (till) (scanner till)

آلة حاسبة إلكترونية

3 number keys

مفتاح الأرقام

4 scanner (light pen)

سكّانر (قلم ضوئي)

5 cash drawer (till)

درج النقدية

6 compartments (money compartments) for coins and notes (Am. bills)

خزّينات للعملة المعدنية والأوراق النقدية

7 receipt (sales check)

إيصال (قسمة مبيعات)

8 amount [to be paid]

المبلغ [المطلوب دفعه]

9 function keys

مفاتيح العمليات

10 goods

بضائع، سلع

11 glass-roofed well

بئر ذو سقف زجاجي

12 men's wear department

قسم الملابس الرجالي

13 showcase (display case, indoor display window)

واجهة عرض، فتريّة (واجهة عرض داخلية)

14 wrapping counter

كاونتر لف البضائع

15 tray for purchases

صينية المشتريات

16 customer

زبون، عميل

17 hosiery department

قسم الجوارب

18 shop assistant (Am. salesgirl, saleslady)

بائع/بائعة

19 price card

بطاقة الأسعار

20 glove stand

حامل القفازات

21 duffle coat, a three-quarter length coat

مخطف "دوفيل"

22 escalator

سلم متحرك

23 fluorescent light (fluorescent lamp)

مصباح فلورسنتي

24 office (e.g. customer accounts office, travel agency, manager's office)

مكتب (مثلا مكتب حسابات العملاء، وكل سياحي، مكتب المدير)

25 poster (advertisement)

إعلان (بوستر)

26 theatre (Am. theater) and concert booking office (advance booking office) (advance booking office)

مكتب حجز تذاكر المسرح والحفلات الموسيقية (مكتب الحجز المسبق)

27 shelves

أرفف

28 ladies' wear department

قسم الملابس النسائية

29 ready-made dress (ready-to-wear dress, coll. off-the-peg dress)

ثوب/فسطان جاهز

30 dust cover

غطاء واق من الغبار

31 clothes rack

شعّاعة الملابس

32 changing booth (fitting booth)

حجيرة قياس الملابس

33 mirror

مرآة

34 dummy

دمية

35 seat (chair)

مقعد (كرسي)

36 fashion journal (fashion magazine)

مجلة أزياء

37 tailor marking a hemline

خيّاط يضع علامة على كفة الثوب

38 measuring tape (tape measure)

شريط قياس

39 tailor's chalk (French chalk)

طباشيرة الخيّاط

40 hemline marker

أداة تعليم كفة الثوب

41 loose-fitting coat

مخطف واسع

42 sales counter

كاونتر المبيعات

43 warm-air curtain

ستارة الهواء الدافئ

44 stairs

سلم، درج

45 lift (Am. elevator)

مصعد

46 lift cage (lift car, Am. elevator car)

صندوق المصعد (عربة المصعد)

47 direction indicators

لُبّات إرشادية للطوابق

48 controls (lift controls, Am. elevator controls)

مفاتيح التحكم

49 floor indicator

مؤشّر الطابق

50 sliding door

باب منزلق

51 lift shaft (Am. elevator shaft)

بئر المصعد

52 bearer cable

كيبل حمل

53 control cable

كيبل التحكم

54 guide rail

مسار دليلي

55 customer

زبون، عميل

56 hosiery

الملابس الداخلية والجوارب

57 linen goods (table linen and bed linen)

مفروشات (مفروشات والمائدة والسريير)

58 fabric department

قسم الأقمشة

59 roll of fabric (roll of material, roll of cloth)

ثوب/ لغة قماش

60 head of department (department manager)

رئيس القسم (مدير القسم)

61 sales counter

كاونتر المبيعات

62 jewellery (Am. jewelry) department

قسم الحليّ والمجوهرات

63 customer assistant

بائعة لمساعدة الزبائن

64 special counter (extra counter)

كاونتر خاص (كاونتر إضافي)

65 placard advertising special offers

لوحّة إعلانات تعلن عروضاً خاصة

66 curtain department

قسم الستائر

67 display on top of the shelves

معروضات فوق الأرفف

272 Park

المُخْتَرَج

1-40 formal garden

حديقة فرنسيّة (حديقة)

5 rake	مِشْطَاط آلة جمع النقود والفيش
6 head croupier	رئيس مديري الطاولة
7 hall manager	مدير القاعة
8 roulette table (gaming table, gambling table)	طاولة الروليت
9 roulette layout	رُقْعَةُ الروليت
10 roulette wheel	عجلة الروليت
11 bank	بنك
12 chip (check, plaque)	فيشة
13 stake	مال مرهنة
14 membership card	بطاقة عضوية
15 roulette player	لاعب الروليت
16 private detective (house detective)	رَجُلْ أَمْنْ سري خاص (رجل أمن تابع للكانينو)
17 roulette layout	رُقْعَةُ الروليت
18 zero (nought, 0)	صفر
19 passe (high) [numbers 19 to 36]	عابر [الأرقام من 19 إلى 36]
20 pair (even numbers)	زُوج (الأرقام الزوجية)
21 noir (black)	أسود
22 manque (low) [numbers 1 to 18]	مُخْفَق (الأرقام من 1 إلى 18)
23 impair [odd numbers]	الأرقام الفردية
24 rouge (red)	أحمر
25 douze premier (first dozen) [numbers 1 to 12]	الدسته الأولى [من رقم 1 إلى 12]
26 douze milieu (second dozen) [numbers 13 to 24]	الدسته الثانية [من رقم 13 إلى 24]
27 douze demier (third dozen) [numbers 25 to 36]	الدسته الثالثة [من رقم 25 إلى 36]
28 roulette wheel (roulette)	عجلة الروليت
29 roulette bowl	إطار الروليت
30 fret (separator)	زخرفة
31 revolving disc (disk) showing numbers 0 to 36	قرص دَوَّارْ يحمل الأرقام من صفر إلى 36
32 spin	دَوَّارة
33 roulette ball	كرة الروليت
276 Board Games and Party Games	أَلْعَابُ الرَقَاعَاتِ والألعب الجماعية الشطرنج
1-16 chess, a game involving combinations of moves, a positional game	رُقْعَةُ الشطرنج وعليها القطع في مواضعها
1 chessboard (board) with the men (chessmen) in position	رُقْعَةُ الشطرنج وعليها القطع في مواضعها
2 white square (chessboard square)	مربع أبيض
3 black square	مربع أسود
4 white chessmen (white pieces) [white = W]	قطعة من قطع الشطرنج البيضاء
5 black chessmen (black	قطعة من قطع الشطرنج

41 flower bed	حَوْضْ زهور
42 park bench (garden seat)	أريكة الحديقة
43 litter bin (<i>Am.</i> trash bin)	صفيحة/سلة المهملات
44 play area	مِنطَقَةُ اللعب
45 stream	جَدْوَلْ مائي
46 jetty	رصيف مائي
47 bridge	جِسْرٌ، كوبري
48 park chair	كُرْسِي الحديقة
49 animal enclosure	حظيرة حيوانات
50 pond	بركة ماء، بحيرة صغيرة
51-54 waterfowl	طيور مائية
51 wild duck with young	بطة برية مع صغارها
52 goose	إوزة
53 flamingo	طائر البشروش، طائر الغلامنجو
54 swan	بجعّة
55 island	جزيرة
56 water lily	زهرة زَيْتُق الماء
57 open-air café	مقهى مكشوف
58 sunshade	مظلة، تende
59 park tree (tree)	شجرة المنتزه (شجرة)
60 treetop (crown)	تاج الشجرة
61 group of trees	مجموعة أشجار
62 fountain	نافورة
63 weeping willow	أشجار الصفصاف
64 modern sculpture	تمثال على نمط الفن الحديث
65 hothouse	دفيئة مستنبت زجاجي مرتفع الحرارة
66 park gardener	بستاني الحديقة
67 broom	مكسّة
68 minigolf course	ملعب جولف صغير
69 minigolf player	لاعب جولف
70 minigolf hole	حفرة كرة الجولف
71 mother with pram (baby carriage)	أم تدفع عربة طفل
72 courting couple (young couple)	حبيبان
273 Children's Playground	مَلْعَبُ الأَطْفَالِ
1 table tennis	تنس الطاولة
2 table	طاولة
3 table tennis net	شبكة تنس الطاولة
4 table tennis racket (raquet) (table tennis bat)	مِضْرَبْ تنس الطاولة
5 table tennis ball	كرة تنس الطاولة
6 badminton game (shuttlecock game)	لعبة الريشة الطائرة
7 shuttlecock	الريشة الطائرة
8 maypole swing	أرْجُوحة سارية نَوَّارْ
9 child's bicycle	دراجة أطفال
10 football (soccer)	كرة القدم
11 goal (goalposts)	المَرْمَى
12 football	الكرة
13 goal scorer	الهداف
14 goalkeeper	حارس المرمى
15 skipping (<i>Am.</i> jumping)	قفز الحبل
16 rope	حبل القفز
17 climbing rope	حبل التسلق
18 rubber tyre (<i>Am.</i> tire)	أرْجُوحة من دولايب مطاطي
19 swing	دولايب شاحنة
20 bouncing ball	كرة نفاطة
21 adventure playground	ملعب المغامرات
22 log ladder	سلم من جذوع الشجر
23 lookout platform	منصة المراقبة
24 slide	زحلوقة
25 litter bin (<i>Am.</i> trash bin)	صندوق المهملات
26 teddy bear	دب لعبة
27 wooden train set	طاقم قطار خشبي
28 paddling pool	بركة ماء
29 sailing boat (yacht, <i>Am.</i> sailboat)	قارب شراعي
30 toy duck	بطة لعبة
31 pram (baby carriage)	عربة طفل
32 high bar (bar)	جهاز العقلة (عقلة)
33 go-cart (soap box)	عربة تتحرك باليدال
34 starter's flag	راية اعلان بداية السباق
35 seesaw	نواصة (أرْجُوحة)
36 robot	إنسان آلي، روبوت
37 flying model aeroplanes (<i>Am.</i> airplanes)	نماذج طائرات
38 model aeroplane (<i>Am.</i> airplane)	نموذج طائرة
39 double swing	أرْجُوحة مزدوجة
40 swing seat	مقعد الأرْجُوحة
41 flying kites	طائرات ورقية
42 kite	طائرة ورقية
43 tail of the kite	ذيل الطائرة الورقية
44 kite string	خيط الطائرة الورقية
45 revolving drum	برميل دَوَّارْ
46 spider's web	بَيْت العنكبوت
47 climbing frame	إطار التسلق
48 climbing rope	حبل التسلق
49 rope ladder	سلم من الحبال
50 climbing net	شبكة التسلق
51 skateboard	لوح الزلق
52 up-and-down slide	زحلوقة متعرجة ارتقاعاً وهبوطاً
53 rubber tyre (<i>Am.</i> tire) cable car	عربة كيبيلية ذات دولايب مطاطي
54 rubber tyre (<i>Am.</i> tire)	دولايب مطاطي
55 tractor, a pedal car	جرار، عربة تسير باليدال
56 den	مَنْحَأً
57 presawn boards	ألواح خشبية جاهزة للتكيب
58 seat (bench)	مقعد (أريكة)
59 Indian hut	كوخ هندي
60 climbing roof	سقف التسلق
61 flagpole (flagstaff)	صاري الراية
62 toy lorry (<i>Am.</i> toy truck)	شاحنة لعبة
63 walking doll	دمية متحركة
64 sandpit (<i>Am.</i> sandbox)	حفرة مملوءة بالرمل
65 toy excavator (toy digger)	حفارة لعبة
66 sandhill	تَلْ رملِي
274 Spa	مَنْتَجِعُ المِيَاهِ المَعْدِنِيَّةِ
1-21 spa gardens	حدائق منتجع المياه المعدنية
1-7 salina (salt works)	الملاحّة
1 thorn house (graduation house)	بيت الزعرور
2 thorns (brushwood)	الزعرور شجيرات شاكنة من الفصيلة الوردية
3 brine channels	قنوات الماء المالح
4 brine pipe from the pumping station	أنبوبة الماء المالح الواصل من محطة الضخ
5 salt works attendant	عامل الملاحّة
6-7 inhalational therapy	العلاج الاستنشاق
6 open-air inhalatorium (outdoor inhalatorium)	منطقة العلاج الاستنشاق المفتوحة
7 patient inhaling (taking an inhalation)	مرضى يقوم بالاستنشاق (ياخذ شهيقاً)
8 hydrophatic (pump room) with kursaal (casino)	مبنى العلاج المائي (غرفة المضخة) وملحق به كازينو
9 colonnade	صف أعمدة، رواق مُعَمَّد
10 spa promenade	التزهة في منتجع المياه المعدنية
11 avenue leading to the mineral spring	طريق مودية إلى نبع المياه المعدنية
12-14 rest cure	العلاج بالاستلقاء في الشمس
12 sunbathing area (lawn)	منطقة أخذ حمامات الشمس
13 deck-chair	كرسي قماش
14 sun canopy	مظلة، تende
15 pump room	حجرة المضخة
16 rack for glasses	رف للأكواب
17 tap	حنفية، صنوبر
18 patient taking the waters	مریضة تتناول المياه
19 bandstand	تحت الفرقة الموسيقية (في الحدائق العامة)
20 spa orchestra giving a concert	الفرقة الموسيقية التابعة للمنتجع وهي تعزف
21 conductor	قائد الفرقة الموسيقية
275 Roulette	الروليت
1-33 roulette, a game of chance (gambling game)	لعبة الروليت، لعبة حظ
1 gaming room in the casino (in the gambling casino)	حجرة اللعب بالمئهى (ملهى لعب القمار)
2 cash desk	مكتب النقدية
3 tourneur (dealer)	موظف تدوير عجلة الروليت (موظف بالكازينو)
4 croupier	مدير الطاولة

pieces) [black = B]	السوداء
6 letters and numbers for designating chess squares in the notation of chess moves and chess problems	حروف وأرقام تحديد مربعات الشطرنج عند التتبع إلى تحركات الشطرنج والمأزق
7 individual chessmen (individual pieces)	قطع الشطرنج الفردية
8 king	الملك
9 queen	المملكة (الوزير)
10 bishop	الغبيل
11 knight	الحصان
12 rook (castle)	الطابية (الرخ)
13 pawn	البيدق
14 moves of the individual pieces	تحركات القطع الفردية
15 mate (checkmate), a mate by knight	إماتة الملك بالحصان
16 chess clock, a double clock for chess matches (chess championships)	ساعة الشطرنج، ساعة مزدوجة لمباريات الشطرنج (بطولات الشطرنج)
17-19 draughts (Am. checkers)	لُعْبَةُ الداما (الضامة)
17 draughtboard (Am. checkerboard)	رقعة الداما
18 white draughtsman (Am. checker, checker-man); also: piece for backgammon and nine men's morris	قَشَاطُ أبيض، أيضاً قَشَاطُ الطاولة ولُعْبَةُ المرية
19 black draughtsman (Am. checker, checker-man)	قَشَاطُ أسود
20 salta	لُعْبَةُ السالطا (القفز)
21 salta piece	قطعة القفز
22 backgammon board	رُقْعَةُ الطاولة
23-25 nine men's morris	لُعْبَةُ المرية
23 nine men's morris board	رُقْعَةُ لُعْبَةِ المرية
24 mill	المِلْ
25 double mill	مِلْ مزدوج
26-28 halma	لُعْبَةُ الهالما
26 halma board	رُقْعَةُ الهالما
27 yard (camp, corner)	ساحة (معسكر، زاوية)
28 halma pieces (halma men) of various colours (Am. colors)	قطع الهالما مختلفة الألوان
29 dice (dicing)	النرد
30 dice cup	كأس النرد
31 dice	زهر النرد
32 spots (pips)	نقط حجر الدومينو
33 dominoes	أحجار لعبة الدومينو
34 domino (tile)	دومينو (حجر)
35 double	حجر زوجي
36 playing cards	ورق اللعب (الكوتشينة)
37 playing card (card)	ورقة الكوتشينة (كارت)
38-45 suits	نقوش ورق اللعب (الكوتشينة)

38 clubs	السباتي
39 spades	السنوني
40 hearts	القلب (الكوبه)
41 diamonds	الديناري (الكاروه)
42-45 German suits	نقوش الورق الألمانية
42 acorns	جوزة البلوط
43 leaves	ورقة الشجر
44 hearts	القلب
45 bells (hawkbells)	الجرس

277 Billiards	البلياردو
1-19 billiards	لُعْبَةُ البلياردو
1 billiard ball, an ivory or plastic ball	كُرَّةُ البلياردو، كُرَّةُ من العاج أو البلاستيك
2-6 billiard strokes	ضربات البلياردو
2 plain stroke (hitting the cue ball dead centre, Am. center)	ضربة عادية (ضرب الكُرَّة في مركزها الميت)
3 top stroke [promotes extra forward rotation]	ضربة علوية [لتوليد دوران أمامي إضافي]
4 screw-back [imparts a direct recoil or backward motion]	ضربة التوليد العكسية [تؤدي إلى حركة حلزونية مباشرة أو حركة خلفية]
5 side (running side, Am. English)	ضربة الجانب الأيسر
6 check side	ضربة الجانب الأيمن
7-19 billiard room (Am. billiard parlor, billiard saloon, poolroom)	صالة البلياردو

7 billiards (English billiards), sim. pool, carrom (carrom billiards)	البلياردو، البلياردو (الإنجليزي)، بالمثل البولة
8 billiards player	لاعب البلياردو
9 cue (billiard cue)	عصا البلياردو
10 leather cue tip	طرف العصا المصنوع من الجلد
11 white cue ball	الكُرَّة البيضاء المدفوعة
12 red object ball	الكُرَّة الحمراء المستهدفة
13 white spot ball (white dot ball)	كُرَّة النقطة البيضاء

14 billiard table	طاولة البلياردو
15 table bed with green cloth (billiard cloth, green baize covering)	أرضية الطاولة ذات غطاء قماش أخضر
16 cushions (rubber cushions, cushioned ledge)	بطانة حافة طاولة البلياردو
17 billiard clock, a timer	ساعة البلياردو، جهاز توقيت
18 billiard marker	لوحة تسجيل نتائج البلياردو
19 cue rack	رف عصي البلياردو

278 Camping and Caravanning (Am. Trailering)	إقامة المخيمات والكرافانات
1-59 camp site (camping site, Am. campground)	موقع المخيم/المعسكر
1 reception (office)	قاعة الاستقبال

2 site warden	مراقب موقع المخيم
3 folding trailer (collapsible caravan, collapsible trailer)	قطيرة قابلة للطي
4 hammock	أرْجوحة شبكية النوم
5-6 washing and toilet facilities	مرافق الغسيل والمراحيض
5 toilets and washrooms (Am. lavatories)	المراحيض ودورات الغسيل
6 washbasins and sinks	أحواض الغسيل والبالوعات

7 bungalow (chalet)	البغلا (شاليه)
8-11 scout camp	معسكر الكشاف
8 bell tent	خيمة نافوسية الشكل
9 pennon	راية
10 camp fire	نار المعسكر
11 boy scout (scout)	صبي كشاف (كشاف)
12 sailing boat (yacht, Am. sailboat)	قارب شراعي (يخت)
13 landing stage (jetty)	رصيف الإرساء (المرسى)
14 inflatable boat (inflatable dinghy)	قارب نفخاخي

15 outboard motor (outboard)	محرك خارجي بموخرة القارب
16 trimaran	زورق مقعد المجدف
17 thwart (oarsman's bench)	مسند المجداف
18 rowlock (oarlock)	مجداف
19 oar	قطيرة القارب (عربة القارب)
20 boat trailer (boat carriage)	قطيرة جيلية الشكل
21 ridge tent	غطاء الخيمة الخارجي
22 flysheet	شداة حبل تثبيت
23 guy line (guy)	وتد نصب الخيمة
24 tent peg (peg)	مطرقة خشبية
25 mallet	حلقه تثبيت فرش الأرضية
26 groundsheet ring	طرف نافوسي
27 bell end	ظلة منصوبة
28 erected awning	مصباح براقين
29 storm lantern, a paraffin lamp	إناء الماء
30 sleeping bag	كيس النوم
31 air mattress (inflatable air-bed)	مرتبة هوائية
32 water carrier (drinking water carrier)	إناء الماء

33 double-burner gas cooker for propane gas or butane gas	جهاز طهي ذو مؤقدين يعمل بغاز البروبين أو البوتان
34 propane or butane gas bottle	أسطوانة غاز البروبين أو البوتان
35 pressure cooker	مُطَبَّخَةٌ طهي بالضغط
36 frame tent	خيمة إطارية
37 awning	ظلة، تدة
38 tent pole	قائم الخيمة
39 meshlarch doorway	مدخل قوسي الشكل
40 mesh ventilator	فتحة تهوية شبكية الشكل
41 transparent window	نافذة شفافة
42 pitch number	رقم الخيمة

43 folding camp chair	كرسي مخيم قابل للطي
44 folding camp table	طاولة مخيم قابلة للطي
45 camping eating utensils	لوازم تناول الطعام في المخيم
46 camper	فرد في المخيم
47 charcoal grill (barbecue)	شواية تعمل بالفحم
48 charcoal	فحم
49 bellows	مفأخ
50 roof rack	شبكة سقف السيارة
51 roof lashing	حبل ربط أحمال فوق سقف السيارة
52 caravan (Am. trailer)	كرافان (قطيرة)
53 box for gas bottle	صندوق أسطوانة الغاز
54 jockey wheel	عجلة القطيرة
55 drawbar coupling	مقرن قضيب الجر
56 roof ventilator	فتحة تهوية سقفية
57 caravan awning	ظلة الكرافان
58 inflatable igloo tent	خيمة قببية قابلة للتمدد
59 camp bed (Am. camp cot)	سرير سفري يمكن طيه

279 Surf Riding (Surfing), Skin Diving	ركوب الأمواج، الغوص
1-6 surf riding (surfing)	ركوب الأمواج المتكسرة
1 plan view of surfboard	منظر أفقي لوح ركوب الأمواج المتكسرة
2 section of surfboard	مقطع عرضي لوح ركوب الأمواج المتكسرة
3 skeg (stabilizing fin)	زعنفة موازنة
4 big wave riding	ركوب الأمواج العالية
5 surfboarder (surfer)	راكب الأمواج المتكسرة
6 breaker	موجة عارمة
7-27 skin diving (underwater swimming)	الغوص
7 skin diver (underwater swimmer)	غواص/غطاس
8-22 underwater swimming set	طاقم جهاز السباحة تحت الماء
8 knife	سكين
9 neoprene wetsuit	لباس غوص مطاطي (من مادة النيوبرين)

10 diving mask (face mask, mask), a pressure-equalizing mask	قناع الغوص
11 snorkel (schnorkel)	الشنكل أنبوب التنفس أثناء السباحة تحت الماء
12 harness of diving apparatus	أحزمة تثبيت جهاز الغوص
13 compressed-air pressure gauge (Am. gage)	مقياس ضغط الهواء المضغوط
14 weight belt	حزام الثقل
15 depth gauge (Am. gage)	مقياس العمق
16 waterproof watch for checking duration of dive	ساعة ضد الماء لمراقبة فترة الغوص

11 diving pool	حمام الغطس
12 straight header	العور والحسم في وضع الاستقامة (فكرة مستقيمة)
13 feet-first jump	فكرة دخول الماء بالقدمين أولاً
14 tuck jump (haunch jump)	فكرة مكورة
15 swimming pool attendant (pool attendant, swimming bath attendant)	مراقب حمام السباحة
16-20 swimming instruction	تعليم السباحة
16 swimming instructor (swimming teacher)	مدرّب السباحة
17 learner-swimmer	شخص يتعلم السباحة
18 float; sim.: water wings	طوف، عوامتان لمساعدة المبتدئ على السباحة
19 swimming belt (cork jacket)	حزام السباحة (سترة فلينية)
20 land drill	تدريب على الأرض
21 non-swimmers' pool	حمام سباحة للتعليم فقط
22 footbath	ممشى
23 swimmers' pool	حمام سباحة للسياح
24-32 freestyle relay race	سباق السباحة الحرة
24 timekeeper (lane time-keeper)	المقياس
25 placing judge	قاضي الوصول
26 turning judge	قاضي التورّان
27 starting block (starting place)	منصة البدء
28 competitor touching the finishing line	منافس يلمس خطّ النهاية
29 starting dive (racing dive)	فكرة الغطس في بدء السباق
30 starter	حكم الانطلاق
31 swimming lane	حارة السباحة
32 rope with cork floats	حبل مزود بطوافات فلينية
33-39 swimming strokes	الضربات المنتظمة
33 breaststroke	للذراعين في السباحة
34 butterfly stroke	ضربة سباحة الصدر
35 dolphin butterfly stroke	ضربة سباحة الفراشة
	الذراعين في السباحة
36 side stroke	ضربة السباحة الجانبية
37 crawl stroke (crawl); sim.: trudgen stroke (trudgen, double over-arm stroke)	ضربة سباحة الكرول، السباحة الحرة
38 diving (underwater swimming)	الغوص (السباحة تحت الماء)
39 treading water	المشي في الماء
40-45 diving (acrobatic diving, fancy diving, competitive diving, highboard diving)	الغطس (الغطس الاكروباتي / مسابقات الغطس)
40 standing take-off pike dive	فكرة من وضع الوقوف ثم الارتفاع
41 one-half twist isander	فكرة مع نصف دورة (فكرة)

17 decometer for measuring stages of ascent	ديكومتر لقياس مراحل الصعود
18 fin (flipper)	زعنفة
19 diving apparatus (aqualung, scuba) with two cylinders (bottles)	جهاز غوص ذو أسطوانتين
20 two-tube demand regulator	منظم دفق الهواء ذو أنبوبين
21 compressed-air cylinder (compressed-air bottle)	أسطوانة هواء مضغوط
22 on/off valve	صمام الفتح/الغلق
23 underwater photography	التصوير تحت الماء
24 underwater camera	كاميرا للتصوير تحت الماء
25 underwater flashlight	فلاش للتصوير تحت الماء
26 exhaust bubbles	فقاعات الهواء المستنفذ
27 inflatable boat (inflatable dinghy)	قارب نفخاخي
280 Bathing Beach	شاطئ الاستحمام
1 lifesaver (lifeguard)	غطاس/سباح (مُنقذ المشرّفين على الغرق)
2 lifeline	حبل الانقاذ
3 lifebelt (lifebuoy)	طوق النجاة من الغرق
4 storm signal	إشارة العاصفة
5 time ball	كرة الوقت
6 warning sign	لافتة تحذير
7 tide table, a notice board showing times of low tide and high tide	لوحة إعلان أوقات المدّ والجزر
8 board showing water and air temperature	لوحة اعلان درجتي حرارة المياه والهوا
9 bathing platform	لسان الاستحمام
10 pennon staff	صاري الراية
11 pennon	راية
12 paddle boat (pedal boat)	قارب بعجلات تجديد
13 surf riding (surfing) behind motorboat	ركوب الأمواج المنكسرة خلف قارب بمحرك
14 surfboarder (surfer)	راكب الأمواج المنكسرة
15 surfboard	لوح ركوب الأمواج المنكسرة
16 water ski	الترحل فوق الماء
17 inflatable beach mattress	مرتبة شاطئ نفخاخي
18 beach ball	كرة البحر
19-23 beachwear	لباس الشاطئ
19 beach suit	بدلة شاطئ
20 beach hat	قبعة شاطئ
21 beach jacket	سترة شاطئ
22 beach trousers	سروال شاطئ
23 beach shoe (bathing shoe)	حذاء شاطئ
24 beach bag	حقية شاطئ
25 bathing gown (bathing wrap)	عباءة الاستحمام (الترنس)
26 bikini (ladies' two-piece bathing suit)	مايوه بكني. لباس استحمام من قطعتين
27 bikini bottom	السيدات
28 bikini top	القطعة السفلية من البكني
29 bathing cap (swimming cap)	القطعة العلوية من البكني
30 bath	طاقية الاستحمام
31 deck tennis (quoits)	سايح، منسجم
32 rubber ring (quoit)	لعبة الكت
33 inflatable rubber animal	حلقة مطاطية (الكت)
34 beach attendant	لعبة مطاطية بشكل حيوان
35 sand castle	قابلة للتفخ
36 roofed wicker beach chair	مراقب الشاطئ
37 underwater swimmer	قلعة من الرمال
38 diving goggles	كرسي شاطئ، منسجف
39 snorkel (schnorkel)	مصنوع من الأمود
40 hand harpoon (fish spear, fish lance)	غواص
41 fin (flipper) for diving (for underwater swimming)	نظارات الغوص
42 bathing suit (swimsuit)	الشركل
43 bathing trunks (swimming trunks)	حربة يدوية (رمح لإصطياد السمك)
44 bathing cap (swimming cap)	زعنفة الغوص
45 beach tent, a ridge tent	
46 lifeguard station	
281 Swimming Bath (Leisure Centre, Am. Center)	حمام السباحة (مركز ترفيهي)
1-9 wave pool, an indoor pool	حمام سباحة ذو أمواج اصطناعية، حمام سباحة مغطى
1 artificial waves	أمواج اصطناعية
2 beach area	منطقة الشاطئ
3 edge of the pool	حافة حمام/بركة السباحة
4 swimming pool attendant (pool attendant, swimming bath attendant)	مراقب حمام/بركة السباحة
5 sun bed	معدّ الاستلقاء في الشمس، معدّ الحمام الشمسي
6 lifebelt	طوق نجاة
7 water wings	عوامتان لمساعدة المبتدئ على السباحة
8 bathing cap	طاقية الاستحمام
9 channel to outdoor mineral bath	قناة تزوي الي بركة مياه معدنية خارجية (مكشوفة)
10 solarium	الشمس
11 sunbathing area	منطقة تريض الجسم للشمس (الحمام الشمسي)
12 sunbather	أحد المستلقين في الحمام الشمسي
13 sun ray lamp	طاقة دخول الأشعة الشمسية
14 bathing towel	منشفة استحمام، بشكير
15 nudist sunbathing area	منطقة الحمام الشمسي
16 nudist (naturist)	الغرة
17 screen (fence)	شخص عار
18 mixed sauna	حاجز (سياج)
19 wood panelling (Am. paneling)	حمام ساونا مختلط
20 tiered benches	تكتية من الألواح الخشبية
21 sauna stove	نصعد متعدد الدرجات
22 stones	مؤد الساونا
23 hygrometer	حجارة
24 thermometer	هايجرومتر جهاز قياس الرطوبة النسبية في الجو
25 towel	ترومومتر مقياس الحرارة
26 water tub for moistening the stones in the stove	منشفة
27 birch rods (birches) for beating the skin	خوص خشبي لترطيب حجارة المؤد
28 cooling room for cooling off (cooling down) after the sauna	عبدان من خضب السندر لضرب البشرة
29 lukewarm shower	حجرة تبريد الجسم بعد الساونا
30 cold bath	دش دافئ
31 hot whirlpool (underwater massage bath)	حمام بارد
32 step into the bath	حمام تدليك دوامي ساخن
33 massage bath	(حمام تدليك تحت الماء)، جاكوزي
34 jet blower	عتبة الحمام
35 hot whirlpool (diagram)	حمام التدليك
36 section of the bath	نافورة نفثة
37 step	رسم تخليطي للحمام التدليك
38 circular seat	الدوامي الساخن
39 water extractor	قطاع من الحمام
40 water jet pipe	درجة (عتبة)
41 air jet pipe	معدّ دائري
	فتحة خروج الماء
	أنبوب نفث الماء (نافورة)
	أنبوب نفث الهواء
282 Swimming	السباحة
1-32 swimming pool, an open-air swimming pool	حمام السباحة، حمام سباحة مكشوف
1 changing cubicle	مقصورة تغيير الملابس
2 shower (shower bath)	الدش
3 changing room	غرفة تغيير الملابس
4 sunbathing area	منطقة الحمام الشمسي
5-10 diving boards (diving apparatus)	منصات/ألواح الغطس (جهاز الغطس)
5 diver (highboard diver)	غطاس
6 diving platform	منصة الغطس
7 ten-metre (Am. ten-meter) platform	منصة الغطس من ارتفاع عشرة أمتار (سلم ثابت)
8 five-metre (Am. five-meter) platform	منصة الغطس من ارتفاع خمسة أمتار (سلم ثابت)
9 three-metre (Am. three-meter) springboard (diving board)	لوحة الغطس من ارتفاع ثلاثة أمتار (سلم متحرك)
10 one-metre (Am. one-meter) springboard	منصة الغطس من ارتفاع متر واحد (سلم متحرك)

31 tiller extension (hikup stick)	المجذاف ذو الذراع
32 tiller	المجذاف
33 rudderhead (rudder stock)	رأس المجذاف
34 rudder blade (rudder)	رأسه الذراع
35 transom	رأسه أفعيه
36 drain plug	سدادة تصريف
37 gooseneck	عنق إوزة
38 window	نافذة، شباك
39 boom	ذراع تطويل قاعدة الشراع
40 foot	قاعدة الشراع
41 clew	القطامة
42 luff (leading edge)	حافة الشراع الأمامية
43 leech pocket (batten cleat, batten pocket)	جيب الضلع العمودي في الشراع
44 batten	شريحة خشبية
45 leech (trailing edge)	ضلع حافة الشراع
46 mainsail	الشراع الرئيسي
47 headboard	للوحّة الرأسية بالشراع
48 racing flag (burgee)	راية السباق
49-65 yacht classes	فئات اليخوت
49 Flying Dutchman	فلاينج داتشمان
50 O-Joller	أو-جولر
51 Finn dinghy (Finn)	الفنّ
52 pirate	البيريرات
53 12.00 m ² sharpie	شاربي 12 م ²
54 tempest	تمبيت
55 star	ستار
56 soling	سولينج
57 dragon	دراجون
58 5.5-metre (Am. 5.5-metre) class	يخت فئة 5.5م
59 6-metre (Am. 6-metre) R-class	يخت فئة 6م - 6 أمتار
60 30.00 m ² cruising yacht (coastal cruiser)	يخت ساحلي 30 م ²
61 30.00 m ² dinghy cruiser	زورق تنزه 30 م ²
62 25.00 m ² one-design keelboat	زورق الكلبت 25 م ²
63 KR-class	فئة كيه آر
64 catamaran	القطنان
65 twin hull	بدن مزدوج
285 Sailing II	الإبحار الشراعي (2)
1-13 points of sailing and wind directions	الإبحار بمحاذاة الريح واتجاهات الريح للإبحار تجاه الريح
1 sailing downwind (running)	الشراع الرئيسي
2 mainsail	شراع السارية الأمامية
3 jib	أشعة منشورة بشكل جناح إوزة
4 sails set goose-winged	خط المنتصف
5 centre (Am. center) line	اتجاه الريح
6 wind direction	يخت متوقف ومقدمته قبالة الريح
7 yacht stopped head to wind	شراع يرتجف
8 sail, shivering	إدارة رأس القارب نحو
9 luffing	

(reverse dive)	عكسية	24 boathouse	عنبر القوارب
42 backward somersault (double backward somersault)	قفزة السمرسولت الخلفية (إدورة ونصف خلفية مكمورة)	25 club's flag	راية النادي
43 running take-off twist dive	قفزة مع لفة كاملة من وضع الجري والارتقاء	26-33 four-oared gig, a touring boat	قارب الجيغ الرباعي
44 screw dive	قفز مع اللف حول المحور	26 oar	مجداف
45 standstand dive (handstand dive)	القفز من وضع الوقوف على اليدين	27 cox's seat	مقعد قائد الدفة
6-50 water polo	كرة الماء	28 thwart (seat)	مقعد متحرك للمجدف
46 goal	الغرضي	29 rowlock (oarlock)	ماسك المجداف (الشكرمة)
47 goalkeeper	حارس المرمى	30 gunwale (gunnel)	الشفير الحافة العليا
48 water polo ball	الكرة (كرة الماء)	31 rising	لوح عمودي لربط الضلوع
49 back	مُدافع، ظهر	32 keel	رافدة القص، صالب القاعدة
50 forward	مُهاجم	33 skin (shell, outer skin) [clinker-built]	القشرة الخارجية للقارب
283 Rowing and Canoeing	التجديف وسباقات التجديف	34 single-bladed paddle (paddle)	مجداف ذو كفة واحدة
1-18 taking up positions for the regatta	أخذ الأماكن استعداداً لبداية السباق	35-38 oar (scull, skull)	مجداف
1 punt, a pleasure boat	البُنط، قارب للتنزه ذو قاع مسطح يدفع بواسطة عصا طويلة تمس قاع النهر	35 grip	مقبض
2 motorboat	قارب بمحرك	36 leather sheath	غلاف جلدي
3 Canadian canoe	قارب الكنو الكندي	37 shaft (neck)	ساق (عنق)
4 kayak (Alaskan canoe, slalom canoe), a canoe	قارب الكيّاك	38 blade	كفة المجداف
5 tandem kayak	كيّاك زوجي	39 double-bladed paddle (double-ended paddle)	مجداف ذو كفتين
6 outboard motorboat (outboard speedboat, outboard)	قارب بمحرك خارجي (في مؤخرة)	40 drip ring	حلقة ناتئة لرد قطرات الماء
7 outboard motor (outboard)	مُحرك خارجي بموخرة القارب	41-50 sliding seat	مقعد منزلق/متحرك
8 cockpit	كابينة القيادة	41 rowlock (oarlock)	ماسك المجداف (الشكرمة)
9-16 racing boats (sportsboats)	قوارب السباق	42 outrigger	ذراع امتداد عرضي
9-15 shells (rowing boats, Am. rowboats)	قوارب التجديف	43 saxboard	حافة مسوية
9 coxless four, a carvel-built boat	قارب رباعي بدون قائد دفة	44 sliding seat	مقعد منزلق/متحرك
10 eight (eight-oared racing shell)	قارب ثماني مع قائد دفة	45 runner	مجري انزلاق المقعد
11 cox	قائد الدفة	46 strut	دعامة انضغاطية
12 stroke, an oarsman	فرد جِذاف، مُجدف	47 stretcher	عارضة ممتدة
13 bow ("number one")	المُجدف الأمامي	48 skin (shell, outer skin)	القشرة الخارجية للقارب
14 oar	مجداف	49 frame (rib)	هيكل (ضلع)
15 coxless pair	قارب زوجي بدون قائد دفة	50 kelson (keelson)	الكلسون عارضة طولية تشد فوق رافدة القص
16 single sculler (single skuller, racing sculler, racing skuller, skiff)	قارب فردي	51-53 rudder (steering rudder)	الدفة (دفة توجيه القارب)
17 scull (skull)	مجداف صغير	51 yoke	مقرن
18 coxed single, a clinker-built single	قارب فردي بقيادة دفة	52 lines (steering lines)	حبلان (حبال التوجيه)
19 jetty (landing stage)	منصة إرساء، رصيف	53 blade (rudder blade, rudder)	راحة الدفة (الدفة)
20 rowing coach	مدرّب تجديف	54-66 folding boats	قوارب قابلة للطي
21 megaphone	ميجافون مكبر صوت	54 one-man kayak	كيّاك فردي
22 quayside steps	درجات سلّم الرصيف	55 canoeist	مجدف قارب الكنو
23 clubhouse (club)	مبنى النادي	56 spraydeck	سطح احتجاز رذاذ الماء
		57 deck	ظهر القارب
		58 rubber-covered canvas hull	بدن القارب مصنوع من قماش القنب مغطى بالمطاط
		59 cockpit coaming (coaming)	جدار القارب
		60 channel for rafts along-side weir	قناة الألوفاف بامتداد سد
		61 two-seater folding kayak, a touring kayak	كيّاك زوجي قابل للطي، قارب كيّاك للتنزه
		62 sail of folding kayak	شراع الكيّاك القابل للطي
		63 leeboard	لوح جانب القارب

- 64 bag for the rods
- 65 rucksack
- 66 boat trailer (boat carriage)
- 67 frame of folding kayak
- 68-70 kayaks
- 68 Eskimo kayak
- 69 wild-water racing kayak
- 70 touring kayak

284 Sailing I
1-9 windsurfing

- 1 windsurfer
- 2 sail
- 3 transparent window (window)
- 4 mast
- 5 surfboard
- 6 universal joint (movable bearing) for adjustable the angle of the mast and for steering
- 7 wishbone
- 8 retractable centreboard (Am. centerboard)
- 9 rudder
- 10-48 yacht (sailing boat, Am. sailboat)
- 10 foredeck
- 11 mast
- 12 trapeze
- 13 crosstrees (spreader)
- 14 hound
- 15 forestay
- 16 jib (Genoa jib)
- 17 jib downhaul
- 18 side stay (shroud)
- 19 lanyard (also: turn-buckle)
- 20 foot of the mast
- 21 kicking strap (vang)
- 22 jam cleat
- 23 foresheet (jib sheet)
- 24 centreboard (Am. centerboard) case
- 25 bitt
- 26 centreboard (Am. centerboard)
- 27 traveller (Am. traveler)
- 28 mainsheet
- 29 foresheet fairlead (jib fairlead)
- 30 toestraps (hiking straps)

- المجذوب من الريح
- حقبية الضبان
- حقبية الظهر
- عربة قطر القارب
- إطار كيّاك قابل للطي
- قوارب الكيّاك
- كيّاك الاسكيمو
- كيّاك السباق في المياه المضطربة
- كيّاك التنزه

الإبحار الشراعي (1)
الركمجة الريّاحية

- راكب الركمجة الريّاحية
- شراع
- نافذة شفافة
- صاري
- لوح الركمجة
- وصلّة عامة لتعديل زاوية الصاري والتوجيه
- ترّفوة
- لوح مركزي قابل للضمّ
- دفة
- اليخوت (قارب شراعي)
- سطح أمامي
- صاري
- شراع مغطّي الشكل
- مضّمات الصاري
- مربط حبل التثبيت الأمامي
- بالصاري
- الحبل الأمامي لتثبيت الصاري
- شراع السارية الأمامية
- مئكاس ذراع السارية الأمامية
- سناد جانبي
- شدّانة
- قاعدة الصاري
- شريط المقاومة
- مربط تثبيت
- حبل ذراع السارية الأمامية
- صندوق اللوح المركزي
- مربط الحبال
- اللوح المركزي
- قضيب المتحركة
- حبل الشراع الرئيسي
- دليل حبل الشراع الأمامي
- سيور الرفع

49 signal for "faster"	إشارة للزيادة
50 signal for "slower" ("slow down")	إشارة للتأخر
51 signal for "speed OK"	إشارة للسرعة الجيدة
52 signal for "turn"	إشارة للمنعطف
53 signal for "stop"	إشارة للتوقف
54 signal for "cut motor"	إشارة لوقف المحرك
55 signal for "return to jetty" ("back to dock")	إشارة "عد إلى المرسى"
56-62 types of water ski	أنواع الزلاجات
56 trick ski (figure ski), a monoski	زلاجة الحركات، زلاجة منفردة
57-58 rubber binding	الأربطة المطاطية
57 front foot binding	رباط القدم الأمامية
58 heel flap	حاشية الكعب
59 strap support for second foot	سناد الرباط الخاص بالقدم الثانية
60 slalom ski	زلاجة التّعرج
61 skeg (fixed fin, fin)	زعنفة ثابتة
62 jump ski	زلاجة القفز
63 hovercraft (air-cushion vehicle)	حزامية (مركبة بوسادة هوائية)
64 propeller	رفاقص، مروحة
65 rudder	الدفة
66 skirt enclosing air cushion	غلاف يحيط بالوسادة الهوائية
287 Gliding (Soaring)	الطيران الشراعي
1 aeroplane (<i>Am.</i> airplane) tow launch (aerotowing)	القطر الجوي بالطائرة
2 tug (towing plane)	طائرة القطر
3 towed glider (towed sailplane)	طائرة شراعية مقطورة
4 tow rope	حبل القطر
5 winched launch	الإطلاق الوثشي
6 motor winch	وتش ذو محرك
7 cable parachute	مظلة كبلية
8 motorized glider (powered glider)	طائرة شراعية بمحرك
9 high-performance glider (high-performance sailplane)	طائرة شراعية عالية الأداء
10 T-tail (T-tail unit)	ذيل تائي الشكل
11 wind sock (wind cone)	مخروط الريح
12 control tower (tower)	برج المراقبة
13 glider field	حقل الطائرات الشراعية
14 hangar	عتبة الطائرات
15 runway for aeroplanes (<i>Am.</i> airplanes)	مدرج الطائرات
16 wave soaring	التحليق الموجي
17 lee waves (waves, wave system)	أمواج مع اتجاه الريح
18 rotor	طيران دوامي
19 lenticular clouds (lenticulars)	سحب عدسية الشكل
20 thermal soaring	التحليق بواسطة الكتل الهوائية الصاعدة
21 thermal	تيار هوائي دافئ، صاعد

10 sailing close-hauled	الريح الإبحار في اتجاه مُعاكس للريح جهه الإمكان
11 sailing with wind abeam	الإبحار والريح مقابلة لمنتصف جانب القارب
12 sailing with free wind	الإبحار في رياح حرة الاتجاه
13 quartering wind (quarter wind)	ريح تهب على جزء من جانب القارب قريب من مؤخرته
14-24 regatta course	مضمار سباق القوارب
14 starting and finishing buoy	عوامة بدء وانتهاء السباق
15 committee boat	قارب لجنة السباق
16 triangular course (regatta course)	مضمار مثلثي (مضمار السباق)
17 buoy (mark) to be rounded	عوامة يتم الدوران حولها
18 buoy to be passed	عوامة يتم اجتيازها
19 first leg	المرحلة الأولى
20 second leg	المرحلة الثانية
21 third leg	المرحلة الثالثة
22 windward leg	مرحلة مواجهة هبوب الريح
23 downwind leg	مرحلة في اتجاه هبوب الريح
24 reaching leg	مرحلة بلوغ منتصف المسافة
25-28 tacking	تغيير اتجاه القارب
25 tack	وجهة القارب
26 gybing (jibing)	انحراف الشراع من جانب إلى آخر فجأة
27 going about	انطلاق القارب
28 loss of distance during the gybe (jibe)	فقدان المسافة أثناء انحراف الشراع
29-41 types of yacht hull	أنواع بدن اليخت
29-34 cruiser keelboat	كلبت الشتره
29 stern	كؤنل
30 spoon bow	مقدم ملعقي
31 waterline	خط الماء
32 keel (ballast keel)	رافدة القص
33 ballast	صابورة
34 rudder	دفة
35 racing keelboat	كلبت سباق
36 lead keel	رافدة قص متقدمة
37-41 keel-centreboard (<i>Am.</i> centerboard) yawl	يول برافدة قص ولوح مركزي
37 retractable rudder	دفة قابلة للضم
38 cockpit	كابينة القيادة
39 cabin superstructure (cabin)	أجزاء الكابينة
40 straight stem	جؤنح مستقيم
41 retractable centre-board (<i>Am.</i> center-board)	لوح مركزي قابل للضم
42-49 types of yacht stern	أنواع كؤنل اليخت
42 yacht stern	كؤنل يخت
43 square stern	كؤنل مربع
44 canoe stern	كؤنل الكنو

45 cruiser stern	كؤنل زورق الشتره
46 name plate	لوحة الاسم
47 deadwood	خشب يابس
48 transom stern	كؤنل برافدة أفقية
49 transom	رافدة أفقية
50-57 timber planking	الثلوج
50-52 clinker planking (clench planking)	تلويع متراكب
50 outside strake	صفيفة الواح طولية خارجية
51 frame (rib)	ضلع
52 clenched nail (riveted nail)	مسامر مثبتت بإحكام
53 carvel planking	تلويح انسيابي
54 ribband-carvel construction	تلويح انسيابي مع ضمامة
55 ribband, a stringer	ضمامة
56 diagonal carvel planking	تلويح انسيابي مائل
57 inner planking	تلويح داخلي
286 Motorboats (Powerboats), Water Skiing	القوارب البخارية، رياضة الانزلاق على سطح الماء القوارب البخارية
1-5 motorboats (powerboats, sportsboats)	قارب فتأخي ذو موتور خارجي بالمؤخرة
1 inflatable sportsboat with outboard motor (outboard inflatable)	قارب فتأخي ذو موتور خارجي بالمؤخرة
2 Z-drive motorboat (outdrive motorboat)	قارب بخاري بمحرك زودياك خارجي
3 cabin cruiser	طواف ذو كابينة قيادة
4 motor cruiser	طواف ذو محرك
5 30-metre (<i>Am.</i> 30-metre) oceangoing cruiser	طواف للإبحار في المحيطات طولك 30مترا
6 association flag	راية الرابطة/القابة
7 name of craft (<i>or:</i> registration number)	اسم القارب (أو رقم التسجيل)
8 club membership and port of registry (<i>Am.</i> home port)	عضوية النادي وميناء التسجيل
9 association flag on the starboard crosstrees	راية الرابطة فوق منصة الصاري الأيمن
10-14 navigation lights of sportsboats in coastal and inshore waters	أضواء الملاحة بالقوارب في المياه الساحلية وقرب الساحل
10 white top light	ضوء أبيض علوي
11 green starboard side-light	ضوء أخضر جانبي في اليمين
12 red port sidelight	ضوء أحمر جانبي
13 green and red bow light (combined lantern)	ضوء مقدمة القارب الأخضر والأحمر (فانوس مزدوج)
14 white stern light	ضوء مؤخرة السفينة الأبيض
15-18 anchors	أنواع المرساة
15 stocked anchor (Admiralty anchor), a	مرساة هليبية

bower anchor	مرساة خفيفة الوزن
16-18 lightweight anchor	مرساة مجزأة
16 CQR anchor (plough, <i>Am.</i> plow, anchor)	مرساة بدون عارض/عارضه
17 stockless anchor (patent anchor)	مرساة دانفورث
18 Danforth anchor	طواف النجاة
19 life raft	سفرة النجاة
20 life jacket	سباق القوارب البخارية
21-44 powerboat racing	القطران، طواف ذو محرك
21 catamaran with outboard motor	بالمؤخرة
22 hydroplane	الطائرة المائية زورق بخاري سريع
23 racing outboard motor	محرك المؤخرة لقارب السباق
24 tiller	ذراع الدفة
25 fuel pipe	أنبوب الوقود
26 transom	رافدة مستعرضة
27 buoyancy tube	أنبوب الطفو
28 start and finish	البداية والنهاية
29 start	البداية
30 starting and finishing line	خط البداية والنهاية
31 buoy to be rounded	طافية يدار حولها
32-37 displacement boats	قوارب تعمل بنظام إزاحة الماء
32-34 round-bilge boat	قارب مستدير الجوف
32 view of hull bottom	منظر قاع بدن القارب
33 section of fore ship	قطاع مقدمة القارب
34 section of aft ship	قطاع مؤخرة القارب
35-37 V-bottom boat (vee-bottom boat)	قارب ذو قاع على شكل V
35 view of hull bottom	منظر قاع بدن القارب
36 section of fore ship	قطاع مقدمة القارب
37 section of aft ship	قطاع مؤخرة القارب
38-44 planing boats (surface skimmers, skimmers)	القوارب السريعة
38-41 stepped hydroplane (stepped skimmer)	طائرة مائية تدرجية (قارب سريع تدرجي)
38 side view	منظر جانبي
39 view of hull bottom	منظر قاع بدن القارب
40 section of fore ship	قطاع مقدمة القارب
41 section of aft ship	قطاع مؤخرة القارب
42 three-point hydroplane	طائرة مائية ثلاثية النقط
43 fin	زعنفة
44 float	طواف
45-62 water skiing	التزلج على الماء
45 water skier	ممارس رياضة التزلج على الماء
46 deep-water start	البداية في الماء العميق
47 tow line (towing line)	حبل الشح
48 handle	مقبض
49-55 water-ski signalling (code of hand signals from skier to boat driver)	إشارات التزلج على الماء (إشارات اليد من المتزلج إلى قائد القارب)

22 cumulus cloud (heap cloud, cumulus, wool-pack cloud)	سَحْب رُكَامِيَّة
23 storm-front soaring	التحليق بِصَدْر العاصفة
24 storm front	صَدْر العاصفة
25 frontal upcurrent	تَيَّار هوائي جِبْهي صاعِد
26 cumulonimbus cloud (cumulonimbus)	رُكَام مَزْنِي
27 slope soaring	التحليق المُتَّصِر
28 hill upcurrent (orographic lift)	تَيَّار هوائي جبليّ صاعد
29 multispar wing	جَنَاح متعدّد العُضد
30 main spar, a box spar	العُضد الرئِسي
31 connector fitting	تَرْكِيبة توَصِيلة
32 anchor rib	ضَلع تثبِيت
33 diagonal spar	عُضد أَمُوق
34 leading edge	الحافة الأمامية
35 main rib	الضلع الرئِسي
36 nose rib (false rib)	ضلع أَسامي (ضلع زائف)
37 trailing edge	الحافة الخلفية
38 brake flap (spoiler)	قِلاَب الكَبح
39 torsional clamp	قَابِطَة التَوَانِيَة
40 covering (skin)	غِلاف خارِجي
41 aileron	جَنِيح
42 wing tip	طَرَف الجَنَاح
43 hang gliding	الطيران بِشِراع التحليق
44 hang glider	شِراع التحليق
45 hang glider pilot	رَبَّان شِراع التحليق
46 control frame	إِطار التَحكُم في شِراع التحليق

288 Aerial Sports (Airsports)

1-9 aerobatics (aerobic manoeuvres, Am. maneuvers)

1 loop	اِتِّقِلاب , تَحَلُّق
2 horizontal eight	شِكل 8 أفِقيَّة
3 rolling circle	دائِرة عَطُوف
4 stall turn (hammer head)	عَطُوف انْهِيارِي
5 tail slide (whip stall)	انْزِلاق بِالذَيل (انْهِيار سَوطِي)
6 vertical flick spin	دوران نَوَلبيّ رأسيّ صاعِد
7 spin	هبوط نَوَلبيّ سَريع
8 horizontal slow roll	تَرَجُّع أفِقي بطِئ
9 inverted flight (negative flight)	طيران مقلوب (طيران سَالِب)
10 cockpit	كابينة القيادة
11 instrument panel	لوحة الآلات
12 compass	بُوصلة
13 radio and navigation equipment	مُعَدَّات الراديو والملاحة
14 control column (control stick)	عصا القيادة
15 throttle lever (throttle control)	ذراع التَحكُم في الخابِق
16 mixture control	مُضَيِّط المِزْج
17 radio equipment	مُعَدَّات الراديو

18 two-seater plane for racing and aerobatics	طائرة ذات مَعَدَّتين للسرِّيات والبهلوانيات
19 cabin	كابينة
20 antenna	هوائي
21 vertical stabilizer (vertical fin, tail fin)	زِعْفَة مَوَازِنَة رأسيَّة
22 rudder	رُفَّة
23 tailplane (horizontal stabilizer)	لوحة الذيل (زعفنة موازنة أفقية)
24 elevator	سطح رافع
25 trim tab (trimming tab)	سطح توازن إضافي
26 fuselage (body)	بدن الطائرة
27 wing	جناح
28 aileron	جَنِيح
29 landing flap	قِلاَب الهبوط
30 trim tab (trimming tab)	سطح توازن إضافي
31 navigation light (position light) [red]	لَمْبَة ضوئية الملاحة [احمر]
32 landing light	لَمْبَة ضوئية الهبوط
33 main undercarriage unit (main landing gear unit)	وَحْدَة عَجَلات الهبوط الرئيسية
34 nose wheel	عجلة المَعْدَمَة
35 engine	مَحْرِك
36 propeller (airscrew)	مِروحة
37-62 parachuting (sport parachuting)	رياضة القفز بالمظلة
37 parachute	مِظَلَّة , بَرِاشوت
38 canopy	قبة المِظَلَّة
39 pilot chute	مِظَلَّة دالِية
40 suspension lines	أحبال التعليق
41 steering line	حبل التوجيه
42 riser	ماسورة صاعدة
43 harness	أحزمة
44 pack	حِمْل
45 system of slots of the sports parachute	نظام الشَقَبات في المِظَلَّة الرياضية
46 turn slots	شَقَبات الدُوران
47 apex	قمة القبة
48 skirt	حافة
49 stabilizing panel	لوحة موازنة
50, 51 style jump	أسلوبا القفز
50 back loop	قفزة دورانية إلى الخلف
51 spiral	قفزة لولبية
52-54 ground signals	الإشارات الأرضية
52 signal for 'permission to jump' ('conditions are safe') (target cross)	إشارة "الإذن للقفز" ("الظروف آمنة")
53 signal for 'parachuting suspended - repeat flight'	إشارة "القفز بالمِظَلَّة مَمْلُق - أعيِد الطيران"
54 signal for 'parachuting suspended - aircraft must land'	إشارة "القفز بالمِظَلَّة مَمْلُق - يجب هبوط الطائرة"
55 accuracy jump	قفزة الدقَّة
56 target cross	الهدف المَحَدَّد
57 inner circle [radius 25 m]	دائرة داخلية [نصف القطر 25 متراً]

58 middle circle [radius 50 m]	دائرة وسطية [نصف القطر 50 متراً]
59 outer circle [radius 100 m]	دائرة خارجية [نصف القطر 100 متر]
60-62 free-fall positions	أوضاع السقوط الحر
60 full spread position	وَضْع فَتْح الذراعَين والسافين
61 frog position	وَضْع الضفدع
62 T position	الوَضْع التائي
63-84 ballooning	ركوب المُنطاد
63 gas balloon	مُنطاد غاز
64 gondola (balloon basket)	عَرَبَة مُسْتَطِيلة (سلة المُنطاد)
65 ballast (sandbags)	ثِقَل مَوَازِنَة (أكياس رمل)
66 mooring line	حبل المرسة
67 hoop	طوق
68 flight instruments (instruments)	مُعَدَّات الطيران
69 trail rope	حبل خلفي
70 mouth (neck)	عق المُنطاد
71 neck line	حبل عق المُنطاد
72 emergency rip panel	لوحة إطلاق غاز المُنطاد في حالة الطوارئ
73 emergency ripping line	حبل إطلاق غاز المُنطاد في حالة الطوارئ
74 network (net)	شبكة
75 rip panel	لوحة إطلاق غاز المُنطاد
76 ripping line	حبل إطلاق غاز المُنطاد
77 valve	صمام
78 valve line	حبل الصمام
79 hot-air balloon	مُنطاد الهواء الساخن
80 burner platform	مِضْطَة المؤدق
81 mouth	فوهة
82 vent	فتحة تهوية
83 rip panel	لوحة إطلاق غاز المُنطاد
84 balloon take-off	إطلاق المُنطاد
85-91 flying model aeroplanes (Am. airplanes)	نماذج الطائرات الطائرة
85 radio-controlled model flight	نموذج طيران يتم التحكم فيه عن بُعد باللاسلكي
86 remote-controlled free flight model	نموذج طيران حر يتم التحكم فيه عن بُعد
87 remote control radio	لاسلكي التحكم عن بُعد هوائي
88 antenna (transmitting antenna)	نموذج يتم التحكم فيه بواسطة حبل
89 control line model	نظام تحكم أحادي الحبل
90 mono-line control system	بيت صغير طائر
91 flying kennel, a K9-class model	

289 Horsemanship, Equestrian Sport

1-7 dressage	الفروسية، رياضة الفروسية
1 arena (dressage arena)	مضمار ترويض الخيل
2 rail	سياج
3 school horse	فرس تعليم
4 dark coat (black coat)	مِظَلَف غامق

5 white breeches	بنطال أبيض
6 top hat	قبعة رسمية
7 gait (also: school figure)	مشية الفرس
8-14 show jumping	القفز الاستعراضى
8 obstacle (fence), an almost-fixed obstacle; sim.: gate, gate and rails, palisade, oxer, mound, wall	حاجز، بوابة، مانع
9 jumper	فرس قفز
10 jumping saddle	سرج قفز الحواجز
11 girth	حزام السرج
12 snaffle	شَكْمَة
13 red coat (hunting pink, pink; also: dark coat)	سترة حمراء (أيضاً سوداء)
14 hunting cap (riding cap)	كاب فروسية
15 bandage	عصابة
16-19 three-day event	مُسابَقة الأيام الثلاثة
16 endurance competition	مُسابَقة قوَّة التحمُّل
17 cross-country	الضاحية
18 helmet (also: hard hat, hard hunting cap)	خوذة
19 course markings	راية تحديد المضمار
20-22 steeplechase	سباق الحواجز
20 water jump, a fixed obstacle	قفز المانع المائي
21 jump	قفزة
22 riding switch	سوط الفرس
23-40 harness racing (harness horse racing)	سباق الخيل بكامل عَدَّتْها
23 harness racing track (track)	مضمار سباق الخيل بكامل عَدَّتْها
24 sulky	عربة الصلحكة
25 spoke wheel (spoked wheel) with plastic wheel disc (disk)	دولاب مُبرَمَق ذو قرص بلاستيكي
26 driver in trotting silks	سائق العربة بزينة الملون
27 rein	بالون الخاص بالإسطبل الذي ينتهي إليه
28 trotter	عنان الفرس
29 piebald horse	فرس أبيض/أسود
30 shadow roll	شريط تحكم
31 elbow boot	وقاء المرفق
32 rubber boot	وقاء مطاطي
33 number	رقم
34 glass-covered grandstand with totalizer windows (tote windows) inside	مدرج مسطوف مغطى بالزجاج به شايك المرَاهنات المُشْرَكة
35 totalizer (tote)	شايك المرَاهنات المُشْرَكة
36 number	رقم
37 odds (price, starting price, price offered)	سعر مرَاهنة (السعر المعروف)
38 winners' table	لوحة الفائز
39 winner's price	سعر الفائز
40 time indicator	مُبَيِّن الوَقت

54 substitute	بديل
55 coach	مدرب
56 shirt (jersey)	قميص، فانتة
57 shorts	سروال قصير، شورت
58 sock (football sock)	شُراب، جُورب
59 linesman	مُرَاقب الخطّ
60 linesman's flag	رَاية مُراقب الخطّ
61 sending-off	طرد من الملعب
62 referee	المكّم
63 red card; also: yellow card	بطاقة حمراء، أيضاً بطاقة صفراء
64 centre (Am. center) flag	راية منتصف الملعب
292 Ball Games II (2) ألعاب الكرة (2)	
1 handball (indoor handball)	كرة اليد
2 handball player, a field player	لاعب كرة اليد
3 attacker, making a jump throw	مهاجم يقوم بقفزة للتسديد
4 defender	مدافع
5 penalty line	خط منطقة الجزاء
6 hockey	الهوكي
7 goal	المرمى
8 goalkeeper	حارس المرمى
9 pad (shin pad, knee pad)	وقاء (واقٍ للساق، واقٍ للركبة)
10 kicker	حذاء ثقيل لرد الكرة
11 face guard	قناع واقٍ
12 glove	قفاز
13 hockey stick	عصا لعبة الهوكي
14 hockey ball	كرة الهوكي
15 hockey player	لاعب الهوكي
16 striking circle	دائرة الهدف
17 sideline	الخطّ الجانبي
18 corner	ركن الملعب
19 rugby (rugby football)	الروكبي
20 scrum (scrummage)	وضع التشابك
21 rugby ball	كرة الروكبي
22 American football (Am. football)	كرة القدم الأمريكية
23 player (football player) carrying the ball	لاعب يحمل الكرة
24 helmet	خوذة
25 face guard	وقاء الوجه
26 padded jersey	قميص مبطن
27 ball (pigskin)	كرة (من جلد الخنزير)
28 basketball	لعبة كرة السلة
29 basketball	كرة السلة
30 backboard	اللوحة الخلفية
31 backboard support	حامل لوحة السلة
32 basket	سلة
33 basket ring	حلقة السلة
34 target rectangle	مستطيل الهدف
35 basketball player shooting	لاعب يصوب الكرة في السلة
36 end line	الخطّ الخلفي
37 restricted area	المنطقة المحظورة
38 free-throw line	خط الرمية الحرة

41-49 hunt, a drag hunt; sim.: fox hunt, paper chase (paper hunt, hare-and-hounds)	الصيّد، الصيّد باقتفاء
41 field	حقّْل
42 hunting pink	سُترة الصيّد
43 whipper-in (whip)	السُّوط (مُساعد الصيّد)
44 hunting horn	بوق الصيّد
45 Master (Master of fox-hounds, MFH)	السيد (مالك كلاب صيّد الثعالب)
46 pack of hounds (pack)	فريق من كلاب الصيّد
47 staghound	كلب الأيائل
48 drag	سَحَابَة تَرَكَ الأثر
49 scented trail (artificial scent)	أثر ذو رائحة
50 horse racing (racing)	سباق الخيول
51 field (racehorses)	مضمار (خيول السباق)
52 favourite (Am. favorite)	الفُرس المُرشَّح للفوز
53 outsider	فُرس خارج المنافسة (غير مرشح للفوز)
290 Cycle Racing and Motorsports	
1-23 cycle racing	
1 cycling track (cycle track); here: indoor track	سباق الدراجات والسيارات
2-7 six-day race	سباق الأيام الستة
2 six-day racer, a track racer (track rider) on the track	مُتسابق مُشارك في سباق الأيام الستة ينافس بالمضمار
3 crash hat	خوذة واقية
4 stewards	المُشرفون
5 judge	القاضي
6 lap scorer	مُسجِّل الدورات المفردة
7 rider's box (racer's box)	صندوق راكب الدراجة
8-10 road race	السباق على الطريق
8 road racer, a racing cyclist	مُتسابق على الطريق
9 racing jersey	قميص السباق
10 water bottle	زجاجة ماء
11-15 motor-paced racing (long-distance racing)	سباق المسافات الطويلة بالدراجات النارية الصغيرة
11 pacer, a motorcyclist	مُتسابق بالدراجات النارية الصغيرة
12 pacer's motorcycle	دراجة صغيرة سريعة
13 roller, a safety device	آلية أمان
14 stayer (motor-paced track rider)	مُتسابق بالمضمار
15 motor-paced cycle, a racing cycle	دراجة صغيرة سريعة
16 racing cycle (racing bicycle) for road racing (road race bicycle)	دراجة سباق الطُرق
17 racing saddle, an unsprung saddle	مقعد دراجة السباق
18 racing handlebars	مقود دراجة السباق
19 tubular tyre (Am. tire)	دولاب أنبوبي
20 chain	جنزير، سلسلة
21 toe clip (racing toe clip)	كلاية تثبيت القدم بالبدال
22 strap	رباط/ شريط تثبيت
23 spare tubular tyre (Am. tire)	إطار أنبوبي احتياطي
24-38 motorsports	
24-28 motorcycle racing; disciplines: grastack racing, road racing, sand track racing, cement track racing, speedway [on ash or shale tracks], mountain racing, ice racing (ice speedway), scramble racing, trial, moto cross	
24 sand track	مضمار رملّي
25 racing motorcyclist (rider)	مُتسابق الدراجات النارية
26 leather overalls (leathers)	أوفرول من الجلد
27 racing motorcycle, a solo machine	دراجة سباق نارية
28 number (number plate)	لوحة رقم الدراجة
29 sidcar combination on the bend	توافق العربة الجانبية عند المنطف
30 sidcar	عربة جانبية
31 streamlined racing motorcycle [500 cc.]	دراجة سباق نارية إنسيابية السطح [500 سي سي]
32 gymkhana, a competition of skill; here: motorcyclist performing a jump	حفلة رياضية، مسابقة إظهار المهارات، هنا راكب دراجة نارية يؤدي قفزة
33 cross-country race, a test in performance	سباق الضاحية، اختبار الأداء
34-38 racing cars	
34 Formula One racing car (a mono posto)	سيارات السباق
35 rear spoiler (aerofoil, Am. airfoil)	سيارة سباق فورميولا 1
36 Formula Two racing car	مُسبّد خلفي
37 Super-Vee racing car	سيارة سباق سويفر في
38 prototype, a racing car	نموذج أولي لسيارة السباق
291 Ball Games I (Football, Association Football, Soccer)	
1-16 football pitch	
1 field (park)	مُستطيل مَلعب كرة القدم
2 centre (Am. center) circle	المَلعب
3 half-way line	دائرة المَرَكز
4 penalty area	خط منتصف الملعب
5 goal area	منطقة الجزاء
6 penalty spot	نقطة ركلة الجزاء
7 goal line (by-line)	خط المرمى
8 corner flag	راية الزاوية
9 touch line	خط التماس
10 goalkeeper	حارس المرمى
11 sweeper (libero)	مدافع/ ظهر متأخر (مُشّاش)
12 inside defender	مدافع/ ظهر أو سط
13 outside defender	مدافع/ ظهر أول (أَيْنر/ أَيْسِر)
14 midfielder players	لاعبيا المنتصف
15 inside forward (striker)	مهاجم (أَيْنر/ أَيْسِر)
16 outside forward (winger)	جناح (أَيْنر/ أَيْسِر)
17 football	كرة القدم
18 valve	بلف
19 goalkeeper's gloves	قفازا حارس المرمى
20 foam rubber padding	حشو من المصطاط الرغوي
21 football boot	حذاء كرة القدم
22 leather lining	بطانة من الجلد
23 counter	كوتنر الحذاء، قطعة جلد قاسية داخل مؤخر الحذاء المحيط بالعقب
24 foam rubber tongue	لسان الحذاء مصنوع من المصطاط الرغوي
25 bands	أشرطة
26 shaft	جانب الحذاء الأمامي الخارجي
27 insole	باطن الحذاء
28 screw-in stud	مسمار، وتد معدني مقلّوب
29 groove	أخدود
30 nylon sole	نعل من النيلون
31 inner sole	نعل داخلي
32 lace (bootlace)	رباط الحذاء
33 football pad with ankle guard	حذاء خاصة ذات واقٍ للكاحلين
34 shin guard	شكار، وقاء الساق
35 goal	المرمى
36 crossbar	عَارضة المرمى
37 post (goalpost)	قائم المرمى
38 goal kick	ركلة مرمى
39 save with the fists	صد الكرة بالقبضتين
40 penalty (penalty kick)	ركلة جزاء
41 corner (corner kick)	ركلة زاوية
42 offside	تسلّل
43 free kick	ركلة حرة
44 wall	حائط
45 bicycle kick (overhead bicycle kick)	ركلة مزدوجة خلفية
46 header	لاعب يضرب الكرة برأسه
47 pass (passing the ball)	تَمْرِيرة
48 receiving the ball (taking a pass)	استقبال الكرة
49 short pass (one-two)	تَمْرِيرة قصيرة (واحد-اثنين)
50 foul (infringement)	خطأ، مخالفة
51 obstruction	إعاقة
52 dribble	مراوغة
53 throw-in	رمية تماس

91 wood, a driver; <i>sim.</i> : brassie (brassy, brassy)	العصا الخشبية
92 iron	العصا المعدنية
93 putter	عصا الإبدال
294 Fencing	الشيش، المسابقة الشيش، المسابقة
1-33 fencing (modern fencing)	شيش المبارزة
1-18 foil	مُضْرِب الشيش
1 fencing master (fencing instructor)	الحلبة
2 piste	خط الاستعداد
3 on guard line	خط المنتصف
4 centre (<i>Am. center</i>) line	متبارزان في أحد الأشواط
5-6 fencers (foil fencers, foilsman, foilists) in a bout	مهاجم في وضع طعن الخصم
5 attacker (attacking fencer) in lunging position (lunging)	مدافع في وضع دفاع
6 defender (defending fencer), parrying	طعنة مستقيمة، إحدى حركات الشيش
7 straight thrust, a fencing movement	دفاع ثلاثي
8 parry of the tierce	خط المبارزة
9 line of fencing	خطوات المبارزة الثلاث (قصيرة، متوسطة، طويلة)
10 the three fencing measures (short, medium, and long measure)	شيش المبارزة
11 foil, a thrust weapon	قفاز المبارزة
12 fencing glove	قباع المبارزة
13 fencing mask (foil mask)	وقاء الرقبة المثبت بالقناع
14 neck flap (neck guard) on the fencing mask	واقى الصدر (سُرَّة المبارزة)
15 metallic jacket	قميص لكمة الشيش
16 fencing jacket	حذاء خفيف بدون كعب
17 heelless fencing shoes	الوضع الأولي لتحية المبارز (وضع الاستعداد)
18 first position for fencer's salute (initial position, on guard position)	المبارزة بالسيف
19-24 sabre (<i>Am. saber</i>) fencing	مبارز بالسيف
19 sabreurs (sabre fencers, <i>Am. saber fencers</i>)	سيف (خفيف)
20 (light) sabre (<i>Am. saber</i>)	قفاز سيف المبارزة
21 sabre (<i>Am. saber</i>) glove (sabre gauntlet)	قناع المبارزة
22 sabre (<i>Am. saber</i>) mask	فتحة في أعلى الرأس
23 cut at head	دفاع الخماسي
24 parry of the fifth (quinte)	سلاح سيف المبارزة
25-33 épée, with electrical scoring equipment	مُرود بجهاز تسجيل كهربائي
25 épéist	لاعب سيف المبارزة

39 substitute	لاعب بديل
40-69 baseball	البيسبول (كرة القاعدة)
40-58 field (park)	الملعب
40 spectator barrier	حاجز المتفرجين
41 outfielder	لاعب في أقصى الملعب، جناح
42 short stop	منطقة توقف وجيز
43 second base	القاعدة الثانية
44 baseman	لاعب القاعدة
45 runner	عداء
46 first base	القاعدة الأولى
47 third base	القاعدة الثالثة
48 foul line (base line)	خط المخالفة (خط القاعدة)
49 pitcher's mound	رابية اللاعبين القاذف
50 pitcher	اللاعب القاذف
51 batter's position	موقع اللاعب الضارب
52 batter	اللاعب الضارب
53 home base (home plate)	موقع الضرب
54 catcher	اللاعب اللاقط
55 umpire	الحكم
56 coach's box	مقصورة/كشك المُضْرِب
57 coach	مُضْرِب
58 batting order	ترتيب لاعبي المُضْرِب
59-60 baseball gloves (baseball mitts)	قفازات البيسبول
59 fielder's glove (fielder's mitt)	قفاز لاعب الحقل
60 catcher's glove (catcher's mitt)	قفاز اللاعب اللاقط
61 baseball	كرة البيسبول
62 bat	عصا المُضْرِب
63 batter at bat	الضارب في وضع استعداد لضرب الكرة
64 catcher	اللاقط
65 umpire	الحكم
66 runner	العداء
67 base plate	لوح القاعدة
68 pitcher	القاذف
69 pitcher's mound	رابية القاذف
70-76 cricket	الكريكيت
70 wicket with balls	الكريكيت بقوامه الخشبية
71 bowling crease	خط الرمي الخلفي
72 popping crease	خط ضرب الكرة بالمضرب
73 wicket keeper of the fielding side	حارس الويكيت
74 batsman	الضارب
75 bat (cricket bat)	مضرب (مضرب الكريكيت)
76 fielder (bowler)	لاعب أو رامي الكرة
77-82 croquet	الكروكيه
77 winning peg	وَتد الفوز
78 hoop	قنطرة
79 corner peg	وَتد الركن
80 croquet player	لاعب الكروكيه
81 croquet mallet	عصا (مضرب) الكروكيه
82 croquet ball	كرة الكروكيه
293 Ball Games III	ألعاب الكرة (3)
1-42 tennis	كرة التنس، كرة المضرب

1 tennis court	ملعب التنس
2 to 3 doubles sideline (sideline for doubles matches); <i>kinds of doubles</i> : men's doubles, women's doubles, mixed doubles	خط جانبي لمباريات الزوجي، أنواع الزوجي زوجي الرجال، زوجي السيدات، زوجي مختلط
3 to 10 base line	خط القاعدة
4 to 5 singles sideline (sideline for singles matches); <i>kinds of singles</i> : men's singles, women's singles	الخط الجانبي للفردى، أنواع الفردى فردي الرجال، فردي السيدات
6 to 7 service line	خط الإرسال
8 to 9 centre (<i>Am. center</i>) line	خط الإرسال الأوسط
11 centre (<i>Am. center</i>) mark	علامة منتصف خط القاعدة
12 service court	حرم الإرسال
13 net (tennis net)	شبكة (شبكة التنس)
14 net strap	شريط الشبكة
15 net post	قائم الشبكة
16 tennis player	لاعب التنس
17 smash	ضربة إرسال هجومية
18 opponent	المنافس
19 umpire	الحكم
20 umpire's chair	مقعد الحكم
21 umpire's microphone	ميكروفون الحكم
22 ball boy	صبي جمع الكرات
23 net-cord judge	حكم الشبكة
24 foot-fault judge	حكم مخالفة وضع القدم
25 centre (<i>Am. center</i>) line judge	حكم خط الإرسال الأوسط
26 base line judge	حكم خط القاعدة
27 service line judge	حكم خط الإرسال
28 tennis ball	كرة التنس
29 tennis racket (tennis racquet, racket, racquet)	مضرب التنس
30 racket handle (racquet handle)	مقبض المضرب
31 strings (striking surface)	أوتار المضرب (سطح ضرب الكرة)
32 press (racket press, racquet press)	ضابط
33 tightening screw	برغي الإحكام
34 scoreboard	لوح النتائج
35 results of sets	نتائج المجموعات
36 player's name	اسم اللاعب
37 number of sets	عدد المجموعات
38 state of play	حالة سير المجموعة
39 backhand stroke	ضربة خلفية
40 forehand stroke	ضربة أمامية
41 volley (forehand volley at normal height)	ضرب الكرة قبل أن تمس الأرض مباشرة
42 service	ضربة الإرسال
43-44 badminton	البادمنتون (الريشة الطائفة)
43 badminton racket (badminton racquet)	مضرب البادمنتون

44 shuttle (shuttlecock)	ريشة البادمنتون
45-55 table tennis	كرة الطاولة
45 table tennis racket (racquet) (table tennis bat)	مضرب كرة الطاولة
46 racket (racquet) handle (bat handle)	مقبض المضرب
47 blade covering	طبقة مطاطية لتغطية المضرب
48 table tennis ball	كرة الطاولة
49 table tennis players; <i>here</i> : mixed doubles	لاعبو كرة الطاولة، هنا زوجي مختلط
50 receiver	مستقبل الكرة
51 server	ضارب الإرسال
52 table tennis table	طاولة كرة الطاولة
53 table tennis net	شبكة كرة الطاولة
54 centre (<i>Am. center</i>) line	خط المنتصف
55 sideline	الخط الجانبي
56-71 volleyball	الكرة الطائرة
56-57 correct placing of the hands	الوضع الصحيح لليدين
58 volleyball	على الكرة
59 serving the volleyball	الكرة الطائرة
60 blocker	رمية الإرسال
61 service area	لاعب حائط الصد
62 server	منطقة الإرسال
63 front-line player	لاعب الخط الأمامي
64 attack area	منطقة الهجوم
65 attack line	خط الهجوم
66 defence (<i>Am. defense</i>) area	منطقة الدفاع
67 referee	الحكم
68 umpire	القاضي (المساعد)
69 linesman	مرآب الخط
70 scoreboard	لوح النتائج
71 scorer	الهداف
72-78 faustball	لعبة كرة الفاوست
72 base line	خط القاعدة
73 tape	شريط
74 faustball	كرة الفاوست
75 forward	مهاجم
76 centre (<i>Am. center</i>)	لاعب المنتصف
77 back	فهير
78 hammer blow	ضربة مطرقية
79-93 golf	الغولف
79-82 course (holes)	ملعب الغولف
79 teeing ground	مكان البدء
80 rough	منطقة وعرة
81 bunker (<i>Am. sand trap</i>)	مطب رملي
82 green (putting green)	المنطقة الخضراء
83 golfer, driving	لاعب الغولف يضرب الكرة
84 follow-through	متابعة الحركة
85 golf trolley	تrolley (عربة) الغولف
86 putting (holing out)	ضرب الكرة إلى داخل الحفرة
87 hole	حفرة أو ثقب
88 pin (flagstick)	عمود العلم
89 golf ball	كرة الغولف
90 tee	موضع البدء

35 hang with elbows bent	التعلق مع ثني المرفقين
36 piked reverse hang	وَضَعُ الحُرْبَةِ العَكْسِيَّ
37 straight inverted hang	التعلق المقلوب مع استقامة الجسم
38 straight hang	التعلق المستقيم
39 bent hang	التعلق مع ثني الذراعين
40-46 grasps (kinds of grasp)	أنواع الممسكات
40 overgrasp on the horizontal bar	مَسْكَةُ العَقْلَةِ واليَدَيْنِ للامام
41 undergrasp on the horizontal bar	مَسْكَةُ العَقْلَةِ واليَدَيْنِ للخلف
42 combined grasp on the horizontal bar	مَسْكَةُ مُرَكَّبَةٌ على العَقْلَةِ
43 cross grasp on the horizontal bar	مَسْكَةُ مُتَقاطعة على العَقْلَةِ
44 rotated grasp on the horizontal bar	مَسْكَةُ اليَدَيْنِ المستديرة على العَقْلَةِ
45 outside grip on the parallel bars	مَسْكَةُ المتوازي من الخارج
46 rotated grasp on the parallel bars	مَسْكَةُ المتوازي من الداخل
47 leather handstrap	شريط من الجلد لليد
48-60 apparatus exercises	تمارين الأجهزة
48 long-fly on the horse	الطيران الطويل فوق حصان الوثب
49 rise to straddle on the parallel bars	الارتفاع لفتح الساقين على المتوازي
50 crucifix on the rings	وَضَعُ النصالب على جهاز الحلق
51 scissors (scissors movement) on the pommel horse	وَضَعُ المقص على حصان الحلق
52 legs raising into a handstand on the floor	رَفْعُ الساقين للوقوف على اليدين على الأرض
53 squat vault on the horse	التقلية في وَضَعُ القرفصاء على الحصان
54 double leg circle on the pommel horse	دائرة مزدوجة بالساقين على حصان الحلق
55 hip circle backwards on the rings	دائرة خلفية بالخصر على جهاز الحلق
56 lever hang on the rings	تعلق الرافعة على جهاز الحلق
57 rearward swing on the parallel bars	العُرْجَةُ الخلفية على المتوازي
58 forward kip into upper arm hang on the parallel bars	حركة كيب أمامية للتعلق بالذراعين على المتوازي
59 backward underswing on the horizontal bar	مُرْجَحَةٌ سفلية للخلف على العَقْلَةِ
60 backward grand circle on the horizontal bar	دائرة واسعة خلفية على العَقْلَةِ
61-63 gymnastics kit	طاقم ملابس الجمناباز
61 singlet (vest, Am. undershirt)	فانلة
62 gym trousers	بنطلون/سروال جمناباز
63 gym shoes	لاصق حذاء جمناباز

26 electric épée; also: electric foil	سلاح سيف المبارزة الكهربائي، أيضاً شيش كهربائي
27 épée point	نقطة الإصابة بالسيف
28 scoring lights	مصابيح تسجيل الإصابة
29 spring-loaded wire spool	بكرة سلك مثبتة على نابض
30 indicator light	مصباح إشاري
31 wire	سلك كهربائي
32 electronic scoring equipment	جهاز التسجيل الإلكتروني
33 on guard position	وَضَعُ الاستعداد
33-45 fencing weapons	أسلحة المبارزة/الشيش
34 light sabre (Am. saber), a cut and thrust weapon	سيف خفيف
35 guard	واقى اليد
36 épée, a thrust weapon	سيف المبارزة، سلاح طابع
37 French foil, a thrust weapon	الشيش الفرنسي، سلاح طابع
38 guard (coquille)	واقى اليد
39 Italian foil	الشيش الإيطالي
40 foil pommel	رمانة السيف
41 handle	مقبض
42 cross piece (quillons)	قطعة مستعرضة
43 guard (coquille)	واقى اليد
44 blade	نصل السلاح
45 button	زر اللبس
46 engagements	اشتباكات بالسيف
47 quarte (carte) engagement	اشتباك "كوارت"
48 tierce engagement (also: sixte engagement)	اشتباك ثلاثي (أيضا سداسي)
49 circling engagement	اشتباك دائري
50 seconde engagement (also: octave engagement)	اشتباك "اوكتاف"
51-53 target areas	المناطق المستهدفة
51 the whole body in épée fencing (men)	الجسم بالكامل في سيف المبارزة (رجال)
52 head and upper body down to the groin in sabre (Am. saber) fencing (men)	الرأس والجذع حتى الأربية في المبارزة بالسيف (رجال)
53 trunk from the neck to the groin in foil fencing (ladies and men)	الجذع من العنق حتى الأربية في سلاح الشيش (سيدات ورجال)
295 Free Exercise	التمرينات الحرة
1 basic position (starting position)	الوضع الأساسي (وضع البدائية)
2 running posture	وضع الجري
3 side straddle	فتح الساقين جانبياً
4 straddle (forward straddle)	فتح الساقين للأمام
5 toe stand	وقوف على أصابع القدمين
6 crouch	وضع "كروش" (التكوير)
7 upright kneeling	جلوس على الركبتين
position	والجسم منتصب
8 kneeling position, seat on heels	جلوس على الركبتين، الجلوس على الكعبين
9 squat	قرفصاء
10 L seat (long sitting)	وضع الجلوس والساقين مفردتين للأمام (وضع على شكل حرف L)
11 tailor seat (sitting tailor-style)	وضع مقعد الخياط
12 hurdle (hurdle position)	وضع "هردل"
13 V-seat	جلوس حرف V
14 side split	وضع فرجاري جانبي أيمن
15 forward split	وضع فرجاري أمامي
16 L-support	الارتكاز على شكل حرف L
17 V-support	الارتكاز على شكل حرف V
18 straddle seat	وضع "سترادل"
19 bridge	حركة الجسر
20 kneeling front support	وضع الارتكاز الأمامي مع الجلوس على الركبتين
21 front support	وضع الارتكاز الأمامي
22 back support	وضع الارتكاز الخلفي
23 crouch with front support	وضع "كروش" مع الدعم
24 arched front support	الارتكاز الأمامي المقوس
25 side support	الارتكاز الجانبي
26 forearm stand (forearm balance)	الوقوف على الذراعين
27 handstand	وقوف على اليدين
28 headstand	وقوف على الرأس
29 shoulder stand (shoulder balance)	وقوف على الكتفين
30 forward horizontal stand (arabesque)	حركة الأرابيسك
31 rearward horizontal stand	وقوف أفقي خلفي
32 trunk-bending side-ways	ثني الجذع للجانب
33 trunk-bending forwards	ثني الجذع للأمام
34 arch	قوس
35 astride jump (butterfly)	قفزة الفراشة
36 tuck jump	قفزة متكورة
37 astride jump	القفز عالياً مع فتح الساقين
38 pike	القفز عالياً مع فرد الساقين والذراعين للأمام
39 scissor jump	قفزة المقص
40 stag jump (stag leap)	قفزة الطلي
41 running step	خطوة الجري للاقترب
42 lunge	وضع الوثب
43 forward pace	خطوة أمامية
44 lying on back	الوقود على الظهر
45 prone position	وضع الانبطاح
46 lying on side	الوقود على الجانب
47 holding arms downwards	فرد الذراعين لأسفل
48 holding (extending) arms sideways	فرد الذراعين جانبياً
49 holding arms raised upward	فرد الذراعين لأعلى
50 holding (extending)	فرد الذراعين للأمام
arms forward	
51 arms held (extended) backward	فرد الذراعين للخلف
52 hands clasped behind the head	مسك اليدين خلف الرأس
296 Apparatus Gymnastics I	جمناباز الأجهزة (1)
1-11 gymnastics apparatus in men's Olympic gymnastics	أجهزة الجمناباز في مسابقات الجمناباز الأوليمبية للرجال
1 long horse (horse, vaulting horse)	حصان الوثب
2 parallel bars	المتوازيان
3 bar	عارضة خشبية
4 rings (stationary rings)	جهاز الحلق
5 pommel horse (side horse)	حصان الحلق
6 pommel	حلفة
7 horizontal bar (high bar)	العقلة
8 bar	عارضة العقلة
9 upright	قائم العقلة
10 stay wires	الشدادات
11 floor (12m x 12m floor area)	منطقة الحركات الأرضية (12م×12م)
12-21 auxiliary apparatus and apparatus for school and club gymnastics	الأجهزة التكميلية وأجهزة الجمناباز الخاصة بالمدراس والأندية
12 springboard (Reuther board)	سلم الوثب
13 landing mat	فرشة الهبوط
14 bench	دكة، بنش
15 box	صندوق
16 small box	صندوق صغير
17 buck	حصان صغير (البك)
18 mattress	مرتبة، حشية
19 climbing rope (rope)	حبل التسلق
20 wall bars	جهاز عوارض جدارية
21 window ladder	سلم تسلق
22-39 positions in relation to the apparatus	الأوضاع بالنسبة للأجهزة
22 side, facing	جانب المواجهة الأمامية
23 side, facing away	جانب المواجهة في الاتجاه المعاكس
24 end, facing	طرف المواجهة الأمامية
25 end, facing away	طرف المواجهة في الاتجاه المعاكس
26 outside, facing	المواجهة الخارجية
27 inside, facing	المواجهة الداخلية
28 front support	ارتكاز أمامي
29 back support	ارتكاز خلفي
30 straddle position	وضع فتح الساقين
31 seated position outside	وضع الجلوس للخارج
32 riding seat outside	وضع الركوب للخارج
33 hang	التعلق
34 reverse hang	التعلق العكسي

القبضة بالإبهام والوسطى
قبضة حدود الفرس
بطانة

299 Weightlifting and Combat Sports

1-5 weightlifting
1 squat-style snatch
2 weightlifter
3 disc (disk) barbell
4 jerk with split
5 maintained lift
6-12 wrestling
6-9 Greco-Roman wrestling
6 standing wrestling (wrestling in standing position)
7 wrestler
8 on-the-ground wrestling (*here*: the referee's position)
9 bridge
10-12 freestyle wrestling
10 bar arm (arm bar) with grapevine
11 double leg lock
12 wrestling mat (mat)
13-17 judo (*sim.*: ju-jitsu, ju-jitsu, ju-jutsu)
13 drawing the opponent off balance to the right and forward
14 judoka (judoist)
15 coloured (*Am.* colored) belt, as a symbol of Dan grade
16 referee
17 judo throw
18-19 karate
18 karateka
19 side thrust kick, a kicking technique
20-50 boxing (boxing match)
20-24 training apparatus (training equipment)
20 spring-supported punch ball
21 punch bag (*Am.* punching bag)
22 speed ball
23 suspended punch ball
24 punch ball
25 boxer, an amateur boxer (boxes in a singlet, vest, *Am.*

رياضات رفع الأثقال والقتال
رفع الأثقال
رفع الخلف
رياح ، رافع أثقال
طارة التقل
التثر مع مبادعة السائقين
حفظ توازن الرفعة
المصارعة
المصارعة اليونانية-الرومانية
المصارعة في وضع الوقوف
مصارع
المصارعة على الأرض
هنا الوضع الإغريقي
قفزة
المصارعة الحرة
تكتيف الذراع مع حركة الكرمة
فقل مزدوج لحركة الساق
بنشاط المصارعة الجودو
جذب الخصم لإفقاذه التوازن
لاعب الجودو
حزام ملون يشير إلى رتبة الدرجة
الحكم
رمية الجودو
الكاراتيه
لاعب الكاراتيه
ركلة طاعة جانبية
الملاكمة
معدات التدريب
كرة التكم المثبتة على نابض
كيس اللكم
كرة السرعة
كرة لكم معلقة
كرة لكم
ملاكم ، ملاكم هاو (ملاكم يرتدي قميصاً بلا أكمام وسروالاً قصيراً) ، أو ملاكم

الوثب العالي
"فوسبري" ، سقطة فوسبري
لاعب الوثب العالي
دوران الجسم

9-27 high jump
9 Fosbury flop (Fosbury flop)
10 high jumper
11 body rotation (rotation on the body's longitudinal and latitudinal axes)
12 shoulder landing
13 upright
14 bar (crossbar)
15 Eastern roll
16 Western roll
17 roll
18 rotation
19 landing
20 height scale
21 Eastern cut-off

22 scissors (scissor jump)
23 straddle (straddle jump)
24 turn
25 vertical free leg

26 take-off
27 free leg
28-36 pole vault
28 pole (vaulting pole)
29 pole vaulter (vaulter) in the pull-up phase
30 swing
31 crossing the bar
32 high jump apparatus (high jump equipment)
33 upright
34 bar (crossbar)
35 box
36 landing area (landing pad)
37-41 long jump
37 take-off
38 take-off board
39 landing area
40 hitch-kick
41 hang
42-47 hammer throw
42 hammer
43 hammer head
44 handle
45 grip
46 holding the grip
47 glove
48 shot put
49 shot (weight)
50 O'brien technique

51-53 javelin throw
51 grip with thumb and

الهبوط على الكتفين
قائم عارضة الوثب
عارضة الوثب
الف الشرقي
الف الغربي
لف
دوران
هبوط
مقياس الارتفاع
حركة الف الشرقية أعلى العارضة
قفزة المقص
القفز مع فتح الساقين
الانعطاف
حركة القفز بالنساق المستقيمة الحرة
ساق حرة
القفز بالزانة
الزانة
لاعب القفز بالزانة في مرحلة جذب الجسم عالياً
مترجحة
تخطي العارضة
جهاز الوثب العالي
قائم
عارضة
صندوق
متعلقة الهبوط
الوثب الطويل
الارتفاع
لوحه الارتفاع
متعلقة الهبوط، الحفرة
رأسه لدفع الجسم للأمام
تعلق في الهواء
رهي المطرقة
المطرقة
رأس المطرقة
ذراع المطرقة
قبضة
مسكة المطرقة
قفاز
قفذ الكرة/البيته
الكرة/البيته
أسلوب "أوبريان" في قذف الكرة/البيته
رهي الرمح
القبضة بالإبهام والوسطى

قفزة البدء على العارضتين
دايرة خلفية حرة على العارضتين
وثبة أمامية على حصان الوثب
وثبة جانبية على حصان الوثب
وثبة خلفية على حصان الوثب
الجمباز والأجهزة اليدوية
قفذ الكرة من يد إلى الأخرى
كرة جمباز
قفذ الكرة عالياً
تطبيق الكرة على الأرض
عمل دائرة باليدين وبهما هراوتين
هراوة الجمباز
مترجحة
قفزة مكررة
عصا خشبية
نط الحبل
حبل
نط الحبل مع تقاطع اليدين
القفز خلال الملوك
طوق الجمباز
دايرة باليد
شكل ثعباني
شريط جمباز
حركة لولبية
طاقم ملابس الجمباز
لباس الجمباز
حذاء جمباز
ألعاب القوى
مسابقات المضمار والحقل
الجري
بداية الجري
مكعب بدء السباق
دواسة قابلة للتعديل
بداية السباق
بداية "كروش"
عداء ، أيضاً: عداء مسافات متوسطة وعداء مسافات طويلة
مضمار الجري
سباق الحواجز
تخطي الحاجز
حاجز
الوثب والقفز

28 upstart on the asymmetric bars
29 free backward circle on the asymmetric bars
30 face vault over the horse
31 flank vault over the horse
32 back vault (rear vault) over the horse
33-50 gymnastics with hand apparatus
33 hand-to-hand throw
34 gymnastic ball
35 high toss
36 bounce
37 hand circling with two clubs
38 gymnastic club
39 swing
40 tuck jump
41 bar
42 skip
43 rope (skipping rope)
44 criss-cross skip
45 skip through the hoop
46 gymnastic hoop
47 hand circle
48 serpent
49 gymnastic ribbon
50 spiral
51-52 gymnastics kit
51 leotard
52 gym shoes

298 Athletics (Track and Field Events)
1-8 running
1-6 start
1 starting block
2 adjustable block (pedal)
3 start
4 crouch start
5 runner, a sprinter; *also*: middle-distance runner, long-distance runner
6 running track (track), a cinder track or synthetic track
7-8 hurdles (hurdle racing); *sim.*: steeple-chase
7 clearing the hurdle
8 hurdle
9-41 jumping and vaulting

رباط للرسغ
جَمبَاز الأَجْهَزة (جَمبَاز السيدات)
أجهزة الجَمبَاز في مسابقات الجَمبَاز الأولمبية للسيدات
حصان الوثب
عارضة التوازن
العارضتان
عارضة خشبية
الشدائد
متعلقة الحركات الأرضية (م12×م12)
الأجهزة التكميلية وأجهزة الجَمبَاز الخاصة بالمدارس والأندية
فُرشة الهبوط
سلم الوثب
صندوق صغير
الترامبولين
قماش مشدود
اطار ، مثبت معدني
نواييز ، زئيركات
مقفز ترامبولين
تمارين الأجهزة
حركة سمرسولد خلفية (الشقلة الخلفية)
وضِع النقاط القافز
حركة سمرسولد رأسية
خلفية على الترامبولين
حركة سمرسولد أمامية على مقفز ترامبولين
دَحْرَجَة أمامية على الأرض
حركة طيران طويل لدَحْرَجَة أمامية على الأرض
حركة عجلة على عارضة التوازن
الفقز على اليدين على حصان الوثب
دوران خلفي
قفزة خلفية على الأرض
دوران حر للأمام على الأرض
دوران أمامي على الأرض
دوران على الرأس للأمام

Recreation, Games, Sport / ترفيه وألعاب ورياضة
64 wristband
297 Apparatus Gymnastics II (Women's Gymnastics)
1-6 gymnastics apparatus in women's Olympic gymnastics
1 horse (vaulting horse)
2 beam
3 asymmetric bars (uneven bars)
4 bar
5 stay wires
6 floor (12m x 12m floor area)
7-14 auxiliary apparatus and apparatus for school and club gymnastics
7 landing mat
8 springboard (Reuther board)
9 small box
10 trampoline
11 sheet (web)
12 frame
13 rubber springs
14 springboard trampoline
15-32 apparatus exercises
15 backward somersault
16 spotting position (standing-in position)
17 vertical backward somersault on the trampoline
18 forward somersault on the springboard trampoline
19 forward roll on the floor
20 long-fly to forward roll on the floor
21 cartwheel on the beam
22 handspring on the horse
23 backward walkover
24 back flip (flik-flak) on the floor
25 free walkover forward on the floor
26 forward walkover on the floor
27 headspring on the floor
906

24 wax scraper	مكشّطة شمّع
25 downhill racing pole	عمسا التزلج المنحدر
26 herringbone, for climbing a slope	طريقة المقص لصعود المنحدر
27 sidestep, for climbing a slope	طريقة السلم لصعود المنحدر
28 ski bag	حقبة التزلج
29 slalom	التزلج المتعرج
30 gate pole	عمود البوابة
31 racing suit	بذلة السباق
32 downhill racing	سباق الانحدار
33 'egg' position, the ideal downhill racing position	وضع "البيضة"، الوضع المثالي لسباق الانحدار
34 downhill ski	مزلّاج الانحدار
35 ski jumping	القفز بالمزلّاج
36 lean forward	الانحناء للأمام
37 number	رقم
38 ski jumping ski	مزلّاج القفز
39 grooves (3 to 5 grooves)	حزوز (3-5 حزوز)
40 cable binding	رباط كبلية
41 ski jumping boots	حذاء القفز بالمزلّاج
42 cross-country	سباق الضاحية
43 cross-country stretch-suit	ساليويت سباق الضاحية
44 course	مضمار
45 course-marking flag	راية تحديد المضمار
46 layers of a modern ski	طبقات مزلّاج حديث
47 special core	لب من مادة خاصة
48 laminates	صفائح رقيقة
49 stabilizing layer (stabilizer)	طبقة موازنة
50 steel edge	حافة من الصلب
51 aluminium (<i>Am.</i> aluminum) upper edge	شفرة علوية من الألومنيوم
52 synthetic bottom (artificial bottom)	قاعدة من مادة صناعية
53 safety jet	إطار أمان
54-56 parts of the binding	أجزاء الرباط
54 automatic heel unit	وحدة الكعب الأمامية
55 toe unit	وحدة أصابع القدم
56 ski stop	مكبح المزلّاج
57-63 ski lift	مصعد التزلج
57 double chair lift	مصعد ذو مقعد مزدوج
58 safety bar with footrest	قضيب أمان مزود بمسند للقدمين
59 ski lift	مصعد التزلج
60 track	مسار، سكة
61 hook	خطاف
62 automatic cable pulley	بكرة كبلية أوتوماتية
63 haulage cable	كبل السحب
64 slalom	التزلج المتعرج
65 open gate	باب مفتوح
66 closed vertical gate	باب عمودي مغلق
67 open vertical gate	باب عمودي مفتوح
68 transversal chicane	عقبة مفتوحة
69 hairpin	منحرف حاد
70 elbow	منحرف مرفقي

undershirt) or a professional boxer (boxes without singlet)	محترف	anorak, snowshirt, padded jacket	
26 boxing glove	قفاز الملاكم	7 breeches (climbing breeches)	سروال قصير
27 sparring partner	ملاكم يتناوش	8 chimney	منشأة
28 straight punch (straight blow)	لكمة مستقيمة	9 belay (spike, rock spike)	صخرة ناتئة لتثبيت الحبل
29 ducking and side-stepping	العيل بالجدع والتحرك جانباً	10 belay	صخرة وتد
30 headguard	واقى الرأس	11 rope sling (sling)	علاقة الحبل
31 infighting; <i>here:</i> clinch	إلتحام	12 rope	حبل
32 uppercut	ضربة مساعدة	13 spur	مهتان
33 hook to the head; <i>here:</i> right hook	ضربة خطافية إلى الرأس؛ هنا - خطافية يمتنى	14-21 snow and ice climbing [snow and ice climbing technique]	تسلق الثلوج والجليد
34 punch below the belt, a foul punch (illegal punch, foul)	لكمة أسفل الحزام، لكمة خاطئة	14 ice slope (firm slope)	منحدر لتجي
35-50 boxing match (boxing contest), title fight (title bout)	مباراة ملاكمة، مباراة على اللقب	15 snow and ice climber	متسلق الثلوج والجليد
35 boxing ring (ring)	حلقة الملاكمة	16 ice axe (<i>Am.</i> ax)	فأس الجليد
36 ropes	أحبال	17 step (ice step)	خطوة
37 stay wire (stay rope)	سلك شداد	18 snow goggles	نظارات واقية من وهج الشمس
38 neutral corner	الزكن المحايد	19 hood (anorak hood)	قلنسوة
39 winner	الفائز	20 cornice (snow cornice)	إفريز (مطف جليدي)
40 loser by a knockout	خاسر بالضربة القاضية	21 ridge (ice ridge)	حافة مرتفعة (حافة جليدية)
41 referee	حكم الحلقة	22-27 rope (roped party)	حبل (مجموعة مرتبطة معا بحبل)
42 counting out	العد حتى عشر ثوان	22 glacier	مكثة
43 judge	قاضي	23 crevasse	شق
44 second	مساعد الملاكم	24 snow bridge	جسر جليدي
45 manager	مدير أعمال الملاكم	25 leader	قائد
46 gong	جرس (عبارة عن قرص معدني)	26 second man (belayer)	الزجل الثاني (فرد ربط الحبل)
47 timekeeper	الميقاني	27 third man (non-belayer)	الزجل الثالث
48 record keeper	المسجل	28-30 roping down (abseiling, rappelling)	الهبوط بالحبل
49 press photographer	مصور صحفي	28 abseil sling	علاقة الهبوط بالحبل
50 sports reporter (reporter)	مقعد "دولفر" لأخبار الرياضة	29 sling seat	مقعد العلاقة
300 Mountaineering	تسلق الجبال	30 Dülfer seat	مقعد "دولفر"
1-57 mountaineering (mountain climbing, Alpinism)	تسلق الجبال (تسلق جبال الألب)	31-57 mountaineering equipment (climbing equipment, snow and ice climbing equipment)	معدات تسلق الجبال والجليد
1 hut (Alpine Club hut, mountain hut, base)	كوخ جبلي (كوخ النادي الألبيني)	31 ice axe (<i>Am.</i> ax)	فأس تسلق الجليد
2-13 climbing [rock climbing] [rock climbing technique]	التسلق	32 wrist sling	حاملة الرسغ
2 rock face (rock wall)	جدار صخري	33 pick	مغول
3 fissure (vertical, horizontal, or diagonal fissure)	شق (رأسي، أفقي، مائل)	34 adze (<i>Am.</i> adz)	قدوم
4 ledge (rock ledge, grass ledge, scree ledge, snow ledge, ice ledge)	حيد، إفريز	35 karabiner hole	عروة
5 mountaineer (climber, mountain climber, Alpinist)	متسلق	36 short-shafted ice axe (<i>Am.</i> ax)	فأس جليد قصيرة الذراع
6 anorak (high-altitude	قلنسوة البركة	37 hammer axe (<i>Am.</i> ax)	فأس مطرقية
		38 general-purpose piton	رزة عامة الأغراض
		39 abseil piton (ringed piton)	رزة حلقية
		40 ice piton (semi-tubular screw ice piton, corkscrew piton)	رزة جليد متولبة
		41 drive-in ice piton	رزة جليد دفعية
		42 mountaineering boot	حذاء تسلق الجبال
		43 corrugated sole	نعل موج
		44 climbing boot	حذاء التسلق

71 corridor	دهليز
72 Allais chicane	عقبة "أنيسز"، مَنُوج
302 Winter Sports II	الرياضات الشتوية (2)
1-26 ice skating	التزلُّق على الجليد
1 ice skater, a solo skater	مُتزلِّق على الجليد
2 tracing leg	رجل تابعة
3 free leg	رجل حرة
4 pair skaters	زوج من المتزلِّقين
5 death spiral	حركة حلزون الموت
6 pivot	حركة المحور
7 stag jump (stag leap)	وثبة المهر
8 jump-sit-spin	دوران القفز والجلوس
9 upright spin	الدوران المنتصب
10 holding the foot	مسك القدم
11-19 compulsory figures	حركات إجبارية
11 curve eight	منحني على شكل 8
12 change	تغيير الاتجاه
13 three	شكل 3
14 double-three	شكل 3 مزدوجة
15 loop	أنشوجة
16 change loop	الأنشوجة المتغيرة مع تغيير الاتجاه
17 bracket	قوس
18 counter	الدائرة العكسية
19 rocker	المهزّة
20-25 ice skates	زلاجات الجليد
20 speed skating set (speed skate)	زلاجة سريعة
21 edge	حافة
22 hollow grinding (hollow ridge, concave ridge)	شفرة الجداء
23 ice hockey set (ice hockey skate)	زلاجة هوكي الجليد
24 ice skating boot	جذاء التزلُّق على الجليد
25 skate guard	وقاء الزلاجة
26 speed skater	متزلِّق سباق السرعة
27-28 skate sailing	التزلُّق الشراعي
27 skate sailor	متزلِّق شراعي
28 hand sail	شراع يدوي
29-37 ice hockey	هوكي الجليد
29 ice hockey player	لاعب هوكي الجليد
30 ice hockey stick	عصا هوكي الجليد
31 stick handle	مقبض العصا
32 stick blade	راحة العصا
33 shin pad	وقاء الساق
34 headgear (protective helmet)	خوذة لحماية الرأس
35 puck, a vulcanized rubber disc (disk)	البكة قرص مطاطي مُشخَّط
36 goalkeeper	في هوكي الجليد
37 goal	حارس المرمى
38-40 ice-stick shooting	رمائية الكرة (الكيرلنج)
(Bavarian curling)	البافاري
38 ice-stick shooter (Bavarian curler)	لاعب الكيرلنج
39 ice stick	عصا الكرة (عصا الجليد)

40 block	كُتَّة
41-43 curling	الكيرلنج
41 curler	لاعب الكيرلنج
42 curling stone (granite)	كرة الكيرلنج (من الجرانيت)
43 curling brush (curling broom, besom)	عصا (فرشاة) الكيرلنج
44-46 ice yachting (ice-boating, ice sailing)	الانزلاق بمراكب الجمد
44 ice yacht (iceboat)	مركب الجمد
45 steering runner	مزلّاق طولي للنوجيه
46 outrigger runner	مزلّاق طولي للإستناد
303 Winter Sports III	الرياضات الشتوية (3)
1 toboggan (sledge, Am. sled)	توبوغان (مزلقة)
2 toboggan (sledge, Am. sled) with seat of plaid straps	توبوغان ذو مقعد من أشرطة النسيج المجدولة
3 junior luge toboggan (junior luge, junior toboggan)	توبوغان صغير بحبل توجيه
4 rein	العنان (حبل التوجيه)
5 bar (strut)	قضيب، سناد
6 seat	مقعد
7 bracket	كتيفة
8 front prop	دعامة أمامية
9 rear prop	دعامة خلفية
10 movable runner	مزلّاق قابل للفصل
11 metal face	واجهة معدنية
12 luge tobogganer	راكب توبوغان بحبل توجيه
13 luge toboggan (luge, toboggan)	توبوغان بحبل توجيه
14 crash helmet	خوذة واقية
15 goggles	نظارات واقية
16 elbow pad	وقاء المرفق
17 knee pad	وقاء الركبة
18 Nansen sledge, a polar sledge	مزلقة قطبية
19-21 bobsleigh (bobsledding)	الانزلاق بمزلقة مزدوجة
19 bobsleigh (bobsled), a two-man bobsleigh (a boblet)	مزلقة مزدوجة لشخصين
20 steersman	فرد توجيه المزلقة
21 brakeman	فرد مكبح المزلقة
22-24 skeleton (Cresta tobogganing)	ركوب التوبوغان الهيكلي
22 skeleton (skeleton toboggan)	هيكل التوبوغان
23 skeleton rider	راكب هيكل التوبوغان
24 rake, for braking and steering	حافة مسنّنة للكبح والتوجيه
304 Countryside in Winter	الريف في الشتاء
1 avalanche (snow)	

avalanche, Am. snowslide; kinds:	هيار جليدي: أنواع هيار
wind avalanche, ground avalanche	ريحي، هيار أرضي
2 avalanche wall, a deflecting wall (diverting wall); sim.:	جدار حارف للهيار الجليدي
avalanche wedge	
3 avalanche gallery	رَوّاق الهيار الجليدي
4 snowfall	سقوط الثلوج
5 snowdrift	مجزوف ثلجي
6 snow fence	سياج احتجاز الثلوج
7 avalanche forest [planted as protection against avalanches]	غابة هيارية [مزرع كوقاء من الهيارات الجليدية]
8 street-cleaning lorry (street cleaner)	شاحنة تنظيف الشوارع
9 snow plough (Am. snowplow) attachment	جرّافة الثلج
10 snow chain (skid chain, tyre chain, Am. tire chain)	سلسلة للوقاية من الانزلاق في الثلج
11 radiator bonnet (Am. radiator hood)	غطاء المشعّ
12 radiator shutter and shutter opening (louvre shutter)	غطاء مغلاق المشعّ وفتحة المغلاق
13 snowman	رجل جليدي
14 snowball fight	التقاذف بكرات الثلج
15 snowball	كرة ثلجية
16 ski bob	دراجة الثلج
17 slide	التزلُّق على الجليد
18 boy, sliding	صنبي يتزلُّق
19 icy surface (icy ground)	سطح جليدي (أرض جليدية)
20 covering of snow (on the roof)	غطاء جليدي (فوق السطح)
21 icicle	دلاة جليدية
22 man clearing snow	رجل يزيح الثلج
23 snow push (snow shovel)	جاروف إزاحة الثلج
24 heap of snow	كومة ثلج
25 horse-drawn sleigh (horse sleigh)	مزلقة يجرها حصان
26 sleigh bells (bells, set of bells)	أجراس المزلقة
27 foot muff (Am. foot bag)	مؤفة تدفئة القدمين
28 earmuff	مؤفة تدفئة الأذنين
29 handsledge (tread sledge); sim.: push sledge	مزلقة يدوية
30 slush	وَحْل جليدي
305 Various Sports	رياضات متنوّعة
1-13 skittles	لعبة القناني الخشبية
1-11 skittle frame	إطار لعبة القناني الخشبية
1 front pin (front)	القارورة الخشبية الأمامية
2 left front second pin	القارورة الخشبية الأمامية

Recreation, Games, Sport / ترفيه وألعاب ورياضة	اليسرى
(left front second)	المسافة ثلاثة [يساراً]
3 running three [left]	القارورة الخشبية الأمامية
4 right front second pin (right front second)	اليمين الثانية
5 running three [right]	المسافة ثلاثة [يميناً]
6 left corner pin (left corner), a corner (copper)	قارورة الزاوية اليسرى
7 landlord	القارورة المركزية
8 right corner pin (right corner), a corner (copper)	قارورة الزاوية اليمنى
9 back left second pin (back left second)	القارورة الخشبية الخلفية اليسرى الثانية
10 back right second pin (back right second)	القارورة الخشبية الخلفية اليمنى الثانية
11 back pin (back)	القارورة الخلفية
12 pin	قارورة خشبية
13 landlord	القارورة المركزية
14-20 tenpin bowling	لعبة البولنج العشرية
14 frame	إطار
15 bowling ball (ball with finger holes)	كرة البولنج
16 finger hole	ثقب الإصبع
17-20 deliveries	أساليب قذف الكرة
17 straight ball	كرة مستقيمة
18 hook ball (hook)	كرة خطافية
19 curve	كرة منحنية
20 back-up ball (back-up)	كرة مائلة
21 boules; sim.: Italian game of bocce, green bowls (bowls)	البولنج الإيطالي
22 boules player	لاعب البولنج الإيطالي
23 jack (target jack)	كرة الهدف البيضاء
24 grooved boule	كرة البولنج الإيطالي المنحدرة
25 group of players	مجموعة من اللاعبين
26 rifle shooting	الرمائية بالبندقية
27-29 shooting positions	أوضاع الرماية
27 standing position	وضع الوقوف
28 kneeling position	وضع البروك/الركوع
29 prone position	وضع الانبطاح/الامتداد
30-33 targets	الاهداف
30 target for 50 m events (50 m target)	هدف مسابقات الرماية من مسافة 50 متراً
31 circle	دائرة
32 target for 100 m events (100 m target)	هدف مسابقات الرماية من مسافة 100 متر
33 bobbing target (tuming target, running-board target)	هدف حرامي/متحرك
34-39 ammunition	الذخيرة
34 air rifle cartridge	خراطوش بندقية تعمل بضغط الهواء
35 rimfire cartridge for zimmerstutzen (indoor target rifle), a small-bore German single-shot rifle	خراطوش بندقية قصيرة المسابرة للرماية في الصالات المغلقة
36 case head	رأس طرف الحقلقة

37 caseless round	طَلقة بدون ظرف
38 .22 long rifle cartridge	خرطوش بندقية طويل عيار 22ر ملم
39 .222 Remington cartridge	خرطوش ريمينجتون عيار 222ر
40-49 sporting rifles	بنادق المسابقات الرياضية
40 air rifle	بندقية تعمل بضغط الهواء
41 optical sight	سداة بصرية
42 front sight (foresight)	سداة أمامية، ناشكاة أمامية
43 smallbore standard rifle	بندقية قياسية قصيرة الماسورة
44 international smallbore free rifle	بندقية دولية قصيرة الماسورة للرمية الحرة
45 palm rest for standing position	مسند اليدين وضع الوقوف
46 butt plate with hook	كحلة الدبشيك/الإخمس وبها عذيفة
47 butt with thumb hole	الدبشيك/الإخمس وثقب الإصبع
48 smallbore rifle for bobbing target (turning target)	بندقية قصيرة الماسورة للأهداف المنحركة
49 telescopic sight (rifle-scope, telescope sight)	سداة تليسكوبية
50 optical ring sight	سداة بصرية حلقة
51 optical ring and bead sight	سداة بصرية بحلقة وقمحة
52-66 archery (target archery)	الرُمي بالسهم
52 shot	الرُمي نحو الهدف
53 archer	رامي السهم
54 competition bow	قوس الرماية في المسابقات
55 riser	شد القوس
56 point-of-aim mark	علامة نقطة التصويب
57 grip (handle)	قبضة
58 stabilizer	أداة موازنة
59 bow string (string)	وتر السهم
60 arrow	سهم
61 pile (point) of the arrow	رأس السهم
62 fletching	تربيش السهم
63 nock	تلم طرف السهم
64 shaft	قصبة السهم
65 cresting	زخرفة
66 target	الهدف
67 Basque game of pelota (jai alai)	لعبة البلوتة الباسكية
68 pelota player	لاعب البلوتة
69 wicker basket (cesta)	سلّة من الأمانيد المجدولة
70-78 skeet (skeet shooting), a kind of clay pigeon shooting	رعي الحمام
70 skeet over-and-under shotgun	بندقية رشّ لرمي الحماص
71 muzzle with skeet choke	فوهة بها خناق

72 ready position on call	وضع الاستعداد عند سماع النداء
73 firing position	وضع الإطلاق
74 shooting range	ميدان الرماية
75 high house	مبنى مرتفع
76 low house	مبنى منخفض
77 target's path	مسار الهدف
78 shooting station (shooting box)	محطة الرماية (صندوق الرماية)
79 aero wheel	العجلة الهوائية
80 handle	مقبض
81 footrest	مسند القدم
82 go-karting (karting)	ركوب العربات الصغيرة المكشوفة
83 go-kart (kart)	عربة صغيرة مكشوفة
84 number plate (number)	لوحة الرقم
85 pedals	دواسات
86 pneumatic tyre (Am. tire)	دولاب ملوّه بالهواء المضغوط
87 petrol tank (Am. gasoline tank)	خزان الوقود
88 frame	إطار
89 steering wheel	عجلة القيادة
90 bucket seat	مقعد دلوي
91 protective bulkhead	حاجز واقٍ
92 two-stroke engine	محرك ثنائي الأشواط
93 silencer (Am. muffler)	شكمان، مخمّد الصوت

306 Carnival

1-48 masked ball (masquerade, fancy-dress ball)	حفلة تنكرية
1 ballroom	صالة المرقص
2 dance band	فريق موسيقي، فريق راقص
3 pop musician	عازف موسيقي البوب
4 paper lantern	فانوس ورقي
5 festoon (string of decorations)	الفسطون، حبل من الزينات
6-48 disguise (fancy dress) at the masquerade	الأزياء التتكرية في الحفلة التتكرية
6 witch	ساحرة
7 mask	فتاع
8 fur trapper (trapper)	صائد الدببة
9 Apache girl	فتاة الأباتشي
10 net stocking	جورب شبكي
11 first prize in the tombola (raffle), a hamper	الجائزة الأولى في الطمبولا
12 pierette	مهرجة
13 half mask (domino)	فتاع نصفي
14 devil	شيطان
15 domino	برنس تنكري
16 hula-hula girl (Hawaii girl)	فتاة رقصة البحتلة
17 garland	إكليل زهور
18 grass skirt (hula skirt)	تورة رقصة البحتلة
19 pierrot	مهرج

20 ruff	الرف طوق رقبة مكشكش
21 midinette	ميدنييت
22 Biedermeier dress	توب سهرة عاري الصدر والكتفين
23 poke bonnet	بوكية
24 décolletage with beauty spot	ديكولتاج مع شامة حسن
25 bayadère (Hindu dancing girl)	راقصة هندوسية
26 grandee	نبيل أسباني
27 Columbine	كولومبين
28 maharaja (maharajah)	مهوراجا
29 mandarin, a Chinese dignitary	موظف صيني
30 exotic girl (exotic)	فتاة شاذة المظهر
31 cowboy; sim.: gaucho (vaquero)	راعي البقر
32 vamp, in fancy dress	إمراة لغوب، مغناج
33 dandy (fop, beau)	غندور
34 rosette	حلبة وردية الشكل
35 harlequin	بليانتش، مهرج
36 gypsy (gypsy) girl	فتاة الفجر
37 cocotte (demi-monde, demi-mondaine, demi-rep)	موميس (امراة مشهوهة)
38 owl-glass, a fool (jester, buffoon)	بهلول
39 foolscap (jester's cap and bells)	طرطور البهلؤل
40 rattle	خشخشينة
41 odalisque, Eastern female slave in Sultan's seraglio	مخطلية (جارية في حريم السلطان في بلاد الشرق)
42 chalwar (pantaloon)	بنطلون/بنطال
43 pirate (buccaneer)	قرصان
44 tattoo	وشم
45 paper hat	قبعة ورقية
46 false nose	أنف زائفة
47 clapper (rattle)	خشخشينة
48 slapstick	مقرعة
49-54 fireworks	الألعاب النارية
49 percussion cap	كبسولة القذح
50 cracker	مقرقة نارية
51 banger	مقرقة نارية
52 jumping jack	الدمية الوثابة
53 cannon cracker (maroon, marroon)	مقرقة مدقعية
54 rocket	صاروخ
55 paper ball	كرة ورقية
56 jack-in-the-box	عفريت العلية
57-70 carnival procession	موكب الكرنفال
57 carnival float (carnival truck)	عربة الكرنفال
58 King Carnival	المالك كرنفال
59 bauble (fool's sceptre, Am. scepter)	صولجان
60 fool's badge	شارة
61 Queen Carnival	الملكة كرنفال
62 confetti	نثار قصاصات من الورق

63 giant	المونّون تنثر في الاحتفالات
64 beauty queen	علاق
65 fairy-tale figure	ملكة الجمال
66 paper streamer	شخصية خرافية (من الحواديت)
67 majorette	راية ملونة خفاقة من الورق
68 king's guard	فتاة من فتيات الموكب
69 buffoon, a clown	حارس الملك
70 lansquenets' drum	بهلول، مهرج
	طبله موكب الكرنفال
307 Circus	المسيرك
1-63 travelling (Am. traveling) circus	سيرك متجول
1 circus tent (big top), a four-pole tent	خيمة السيرك
2 tent pole	عمود الخيمة
3 spotlight	أضواء كاشفة
4 lighting technician	فني الإضاءة
5 trapeze platform	منصة أرجوحة السيرك
6 trapeze	أرجوحة السيرك
7 trapeze artist	لاعب أرجوحة السيرك
8 rope ladder	سلم من الحبال
9 bandstand	تحت الفرقة الموسيقية
10 circus band	فرقة السيرك الموسيقية
11 ring entrance (arena entrance)	مدخل الحلبة
12 wings	جناحان
13 tent prop (prop)	سناد الخيمة
14 safety net	شبكة الأمان
15 seats for the spectators	مقاعد المشاهدين
16 circus box	مقصورة السيرك
17 circus manager	مدير السيرك
18 agent	وكيل
19 entrance and exit	باب الدخول والخروج
20 steps	درجات سلمية
21 ring (arena)	حلبة
22 ring fence	سياج الحلبة
23 musical clown (clown)	مهرج موسيقي
24 clown	مهرج
25 comic turn (clown act), a circus act	فقرة كوميدية
26 circus riders (bareback riders)	راكبو حصان السيرك
27 ring attendant, a circus attendant	عامل السيرك
28 pyramid	تشكيل هرمي
29 support	لاعب ارتكاز
30-31 performance by liberty horses	عرض الخيول البرية
30 circus horse, performing the levade (pesade)	حصان السيرك يقوم بالترقب
31 ringmaster	سيد الحلبة، مدرب قافز
32 vaulter	مخرج الطوارئ
33 emergency exit	مخرج الطوارئ
34 caravan (circus caravan, Am. trailer)	قطيرة (كرفان السيرك)
35 springboard acrobat	بهلولان لوح الوثب

- (springboard artist)
36 springboard لَوْح الوَثْبِ
37 knife thrower قاذف السكاكين
38 circus marksman رامى السيرك
39 assistant مُسَاعِدَة
40 tightrope dancer راقص الحبل المشدود
41 tightrope حبل مشدود
42 balancing pole قضيب حفظ التوازن
43 throwing act حركة قذف
44 balancing act حركة توازن
45 support لاعب ارتكاز
46 pole (bamboo pole) عصا (عصا من الخيزران)
47 acrobat بهلوان
48 equilibrist (balancer) لاعب توازن
49 wild animal cage, a round cage قفص الحيوانات المتوحشة
50 bars of the cage قضبان القفص
51 passage (barred passage, passage for the wild animals) ممر (ممر مسبَّح بالقضبان لمرور الحيوانات المتوحشة)
52 tamer (wild animal tamer) مروض (مدرب الحيوانات المتوحشة)
53 whip كُرْبَاج ، سوط
54 fork شوكة
55 pedestal قاعدة
56 wild animal (tiger, lion) حيوان متوحش (نمر، أسد)
57 stand حامل
58 hoop (jumping hoop) طُوق (طُوق الفَنَز)
59 seesaw نُؤاسَة (أرْجوحة)
60 ball كرة
61 camp مخيم
62 cage caravan كرفان الأقفاص
63 menagerie مَعرَضُ اللُوحُوشِ
- 308 Fair, Fairground .**
1-69 fair (annual fair) أرض السوق
1 fairground سوق (السوق السنوية)
2 children's merry-ground, (whirligig), a roundabout (*Am.* carousel) أرض السوق
3 refreshment stall أَرْجوحة نُوَاسَة الخيل
4 chairplane كُتْكُ المَرطِبَاتِ
5 up-and-down round-about الكراسي الطائرة
6 show booth (booth) أَرْجوحة دَوَّارَة
7 box (box office) حُجْرَة الإِسْتِعْرَاضِ
8 barker شَبَاك التَّدَاكِرِ
9 medium مَنَادِ
10 showman الوَسِيطة الرَّحَابِيَة
11 try-your-strength machine رَجُل الإِسْتِعْرَاضِ
12 hawker ماكينَة اسْتِعْرَاضِ القُوَّةِ
13 balloon بائِع مَتَجُولِ
14 paper serpent بالونة
15 windmill تَعْبَانِ وِرْقِي
 دَوَّارَة الرِّيَاحِ

- 16** pickpocket (thief) نَشَال
17 vendor بائِع
18 nougat نُوجَة
19 ghost train قِطَار الأَشْبَاحِ
20 monster وحش
21 dragon تينين
22 monster وحش
23 beer marquee سُرَاق
24 sideshow اسْتِعْرَاضِ جَانِبِي
25-28 travelling (*Am.* travelling) **artistes** (traveling show people) الفَنَانُونَ الجَوَّالُونَ
25 fire eater أَكَل النَّارِ
26 sword swallower بَالِغ السُّيُوفِ
27 strong man القُوَّة
28 escapologist لَاعِب التَّكْطُّسِ مِنَ الأَغْلالِ
29 spectators المُشَاهِدُونَ ، المُنظَّرَة
30 ice-cream vendor (ice-cream man) بائِع الأيس كريم/ البوظة
31 ice-cream comet, with ice cream بَسْجُوَة أيس كريم
32 sausage stand مَنصَّة بِيع المَقَانِقِ
33 grill (*Am.* broiler) مِسْوَاة
34 bratwurst (grilled sausage, *Am.* broiled sausage) مَقَانِقِ مَسْوَية
35 sausage tongs ماسك المقانق
36 fortune teller العرافة
37 big wheel (Ferris wheel) أَرْجوحة السَّافِيَة
38 orchestrian (automatic organ), an automatic musical instrument أَرغُن الي
39 scenic railway (switch-back) أَرْجوحة سكة حديدية
40 toboggan slide (chute) صغيرة تجري بين مناظر اصطناعية
41 toboggan slide (chute) زَحْلُوقَة التوبوغان
42 swing boats أَرْجوحة القَوَارِبِ
43 swing boat, turning full circle قارب أَرْجوحة يدور دَوَّرة كاملة
44 full circle دَوَّرة كاملة
45 lottery booth (tombola booth) كِتْكَة اللواترية/ الطمولو
46 wheel of fortune عَجَلَة الحظ
47 devil's wheel (typhoon wheel) عَجَلَة الشَّيْطَانِ
48 throwing ring (quoit) حَلْقَة القَنَدِ (الكَت)
49 prizes جوائز
50 sandwich man on stilts بائِع سندوتشات يسير فوق طُولَتَيْنِ
51 sandwich board إعلَانِ عَنِ السندوتشات
52 cigarette seller, an itinerant trader (a hawkler) بائِع سِجَار مَتَجُولِ
53 tray صينيَة
54 fruit stall كُتْكُ الفاكهة
55 wall-of-death rider لَاعِب جِدَارِ المَوْتِ
56 hall of mirrors قاعة العُرَايا (المُضَاجِعة)
57 convex mirror مرآة مُحدِّبة
58 shooting gallery رَكْنِ لَعِبَة الرَّمَاية
59 giant swing boat أَرْجوحة القارب المعلق
60 junk stalls (second-hand stalls) أَكْشَاك بِيْع البَضَائِعِ المُسْتَعْمَلَة
61 first aid tent (first aid post) خِيْمَة الإِسْعَافَاتِ الأَوَّلِيَة
62 dodgems (bumper cars) لَعِبَة سيارَاتِ التصادم
63 dodgem (bumper car) سيارَة تصادم
64-66 pottery stand مَنصَّة بِيْع الفَخَّارِيَّاتِ
64 barker المَنَادِي عَلى المَعْرُوضَاتِ
65 market woman بائِعَة السُوقِ
66 pottery أَوَارِجِ فَخَّارِيَة
67 visitors to the fair زُورِائِ السُوقِ
68 waxworks مَشْفُولَاتِ مِنَ الشَّعْمِ
69 wax figure تمثال مِنَ الشَّعْمِ
- 309 Flea Market سوق البَيْعِ الرَّحِيصَة**
أو المَسْتَحْمَلَة
1 treadle sewing machine ماكينَة خِيَاطة بَدَوَّاسَة
2 flower vase زَهْرِيَة ، مَزَهْرِيَة
3 wall mirror مرآة حائظ
4 cylindrical stove مَوْقدِ اسْطُوانِي
5 stovepipe ماسورة المَوْقدِ
6 stovepipe elbow مرفق ماسورة المَوْقدِ
7 stove door باب المَوْقدِ
8 stove screen سِتَار المَوْقدِ
9 coal scuttle دَلْو الفَحْمِ
10 firewood basket سَلَّة خَطْبِ
11 doll دُمِيَة
12 teddy bear دُب لَعْبَة
13 barrel organ أَرغُن يدوي
14 orchestrian أَرغُن الي
15 metal disc (disk) قُرْصِ مَعْدِنِي
16 radio (radio set, *loc.:* 'steam radio'), a super heterodyne (superhet) مِذيَاع ، راديو
17 baffle board لَوْحِ حَجَزِ المَوْجَاتِ الصوتِيَة
18 'magic eye', a tuning indicator valve "عين سِخْرِيَة" ، صمام دَلِيلِي للضبط الدقيق
19 loudspeaker aperture فتحة مَكْر الصوتِ
20 station selector buttons (station preset buttons) مَفَاتِيحِ اِنْتِقَافِ القنَوَاتِ
21 tuning knob مَفْتَاحِ المَوْالَفَة
22 frequency bands نِظَاقَاتِ الترددِ
23 crystal detector (crystal set) كَشَافِ كَرِيستَالِي
24 headphones (headset) سَمَاعَاتِ الرَّاسِ
25 folding camera كَامِيرَا قَابِلَة لِلطِّي
26 bellows مِثْقَاحِ الكَامِيرَا
27 hinged cover غِطَاءِ مِفصَلِي
28 spring extension وَصْلَة أَمْتَدَادِيَة نَابِضِيَة
29 salesman بائِع
30 box camera كَامِيرَا صَدْقِيَة
31 gramophone الفونوغراف
32 record (gramophone record) اسْطُوانَة فونوغراف
33 needle head with رأس إِبْرِي وَبِه إِبْرَة

- gramophone needle الوَبُو عَرَاغِ
34 horn هُورْنِ
35 gramophone box مَسْبُوحُ الوَبُو عَرَاغِ
36 record rack مَسْبُوحُ الأَسْطُوانَاتِ
37 portable tape recorder مَسْبُوحُ سُورَاتِ مَعَالِي
38 flashgun مَسْبُوحُ وَصْفِي
39 flash bulb لَمْبَة وَصْفِيَة
40-41 electronic flash (electronic flashgun) مَضِباحٌ وَصْفِيٌّ إلكتروني
40 flash head رأس المصباح الوميضي
41 accumulator مَرَكْمِ
42 slide projector فَانُوسِ عَرْضِ الشرائعِ (السللايدات)
43 slide holder حَامِلِ الشرائعِ
44 lamphouse مِبيْتِ المَصْبَاحِ
45 candlestick شَمْعَمَدَانِ
46 scallop shell صَدْفَة مَحَارَة
47 cutlery لَوَارِجِ مَائِدَة
48 souvenir plate دَرَجِ تَذْكَارِي
49 drying rack for photographic plates رَفِ تَجْفِيْفِ الأَوَاقِ التَّصويرِ
50 photographic plate لَوْحِ تَصويرِ
51 delayed-action release زَمْرُ الفِعْلِ المَوْخَرِ
52 tin soldiers (*sim.:* lead soldiers) تَمَائِلِ عَلى شَكْلِ جُنُودِ مِنَ الصَّفِيعِ
53 beer mug (stein) كُوبِ الحِجَّةِ
54 bugle نَغْفِير ، بُوق ، صُور
55 second-hand books كُتُبِ مُسْتَعْمَلَة
56 grandfather clock سَاعَة دَقَاقَة قَائِمَة
57 clock case صَدْرُوقِ السَاعَة
58 pendulum بِنْدُولِ السَاعَة
59 time weight ثِقَلُ الوَقْتِ
60 striking weight ثِقَلُ دَقَاتِ السَاعَة
61 rocking chair كُرْسِي هَزَانِ
62 sailor suit بَذْلَة بَحَّارِ
63 sailor's hat قَبْعَة بَحَّارِ
64 washing set مَلْعَمِ غَسِيلِ
65 washing basin حَوْضِ غَسِيلِ
66 water jug إِبْرِيْقِ المَاءِ
67 washstand حَامِلِ حَوْضِ الغَسِيلِ
68 dolly المَضْرَبَة - أَدَاة لَتْقَلِيبِ المَلابِسِ أَثناءِ الغَسِيلِ
69 washtub وَغَاءِ غَسِيلِ (طَبْشَت)
70 washboard لَوْحِ غَسِيلِ
71 humming top نَحْلَة طَفَّانَة أَوْ خَذْرُوفِ (لَعْبَة)
72 slate لَوْحِ أَرْدُوَازِ لِلكَتَابَة
73 pencil box عِلْبَة أَقْلَامِ رِصَانِصِ
74 adding machine ماكينَة جَمْعِ
75 paper roll بَكْرَة وَرَقِ
76 number keys مَفَاتِيحِ الأرقامِ
77 abacus مِعداد (مِعداد)
78 inkwell, with lid دَوَّارَة حَبْرِ ذاتِ غِطَاءِ
79 typewriter آلَة كَاتِبَة
80 [hand-operated] آلَة حَاسِبَة يدويَة
81 operating handle ذراع تَشغِيلِ
82 result register (product مَسْجَلِ نَتَائِجِ العَمَلِيَّاتِ

register)
83 rotary counting mechanism (rotary counter)
84 kitchen scales
85 waist slip (underskirt)
86 wooden handcart
87 wall clock
88 bed warmer
89 milk churn
310 **Films (Motion Pictures) I**
1-13 film studios (studio complex, *Am.* movie studios)
1 lot (studio lot)
2 processing laboratories (film laboratories, motion picture laboratories)
3 cutting rooms
4 administration building (office building, offices)
5 film (motion picture) storage vault (film library, motion picture library)
6 workshop
7 film set (*Am.* movie set)
8 power house
9 technical and research laboratories
10 groups of stages
11 concrete tank for marine sequences
12 cyclorama
13 hill
14-60 shooting (filming)
14 music recording studio (music recording theatre, *Am.* theater)
15 'acoustic' wall lining
16 screen (projection screen)
17 film orchestra
18 exterior shooting (outdoor shooting, exterior filming, outdoor filming)
19 camera with crystal-controlled drive
20 cameraman

الحسابية
 آلية حساب دَوَّارة
 ميزان مطبخ
 جيبونة (ثورة تحتيّة)
 عربّة يد خشبية
 ساعة حائط
 جهاز تدفئة السرير
 قسط اللبن
الأفلام السِّينمائية (I)
 استوديوهات التصوير السينمائي
 أرض الاستديو
 معامل تحميص الأفلام
 حجرات تنقيح الأفلام السينمائية والأشرطة المسجلة
 مبنى الإدارة
 مكتبة الأفلام
 ورشة
 منظر سينمائي
 وحدة توليد الطاقة
 المعامل الفنية ومعامل البحث
 مجموعات من المنصات / المسارح
 خزّان خرساني لأخذ سلسلة لقطات بحرية متعاقبة
 ستارة سيكلورامية
 تلّ
 تصوير اللقطات
 ستوديو تسجيل الموسيقى
 بطانة جدار صوتيّة
 شاشة (شاشة إسقاط الصورة)
 أوركسترا موسيقى الفيلم التصويرية
 تصوير مناظر خارجيّة
 كاميرا ذات مقوّد تحكّم بلوري
 المصوّر

مساعد المخرج
 مشغّل ذراع الميكروفون
 مهندس تسجيل الصوت
 جهاز تسجيل صوت مَحْمُول ذو مقوّد تحكّم بلوري
 ذراع الميكروفون
 التصوير داخل الاستديو
 مدير الإنتاج
 بطلّة الفيلم
 بطل الفيلم
 كوميّاس الفيلم
 مجموعة مرتّبة من الميكروفونات الصوتيّة
 المصمّم والمؤثرات الصوتيّة
 ميكروفون الاستوديو
 كبل الميكروفون
 الأسطح الجانبية وخلفية المنظر
 عامل "الكلايكيت"
 لوح "الكلايكيت" ويحمل اسم الفيلم ورقم اللقطة ورقم المنظر
 الماكير (مصنّف الشّعر)
 فني الإضاءة
 سيار نشر الضوء
 فتاة السيناريو
 مخرج الفيلم
 المصور (مصور أوّل)
 مساعد المصوّر، مشغّل الكاميرا
 مصمّم المناظر (المدير الفني)
 مدير التصوير
 سيناريو الفيلم
 مخرج مساعد
 كاميرا تصوير سينمائي
 بعازل الصوت

camera (cinemascope camera)
48 soundproof housing (soundproof cover, blimp)
49 camera crane (dolly)
50 hydraulic stand
51 mask (screen) for protection from spill light (gobo)
52 tripod spotlight (fill-in light, filler light, fill light, filler)
53 spotlight catwalk
54 recording room
55 recording engineer (sound recordist)
56 mixing console (mixing desk)
57 sound assistant (assistant sound engineer)
58 magnetic sound recording equipment (magnetic sound recorder)
59 amplifier and special effects equipment, e.g. for echo and sound effects
60 sound recording camera (optical sound recorder)
311 **Films (Motion Pictures) II**
1-46 sound recording and re-recording (dubbing)
1 magnetic sound recording equipment (magnetic sound recorder)
2 magnetic film spool
3 magnetic head support assembly
4 control panel
5 magnetic sound recording and playback amplifier
6 optical sound recorder (sound recording camera, optical sound recording equipment)
7 daylight film magazine
8 control and monitoring panel
9 eyepiece for visual

مبيت كاميرا عازل للصوت
 منجّمة تحريك الكاميرا
 حامل هيدرولي
 سِتّار للحماية من الضوء الزائد
 ضوء كشاف على حامل ثلاثي
 ممّر الأضواء الكاشفة
 حجّرة التسجيل
 مهندس (تسجيل) الصوت
 كونسول المَكْساج (الدمج)
 مساعد مهندس الصوت
 مسجّل صوت مغناطيسي
 مُضَمّن الصوت ومُبدّات المؤثرات الخاصة
 كاميرا تسجيل صوتي (مسجّل صوت صوتي)
تسجيل الصوت والدوبلاج
 معدات تسجيل صوت مغناطيسي
 بكرّة الشريط المغناطيسي
 مجموعة حامل الرأس المغناطيسي
 لوحة التحكم
 مجسّم الصوت الخاص
 يشجّل الصوت المغناطيسي وتشغيله
 مسجّل الصوت الصوتيّ
 مخزّن حفظ الفيلم في ضوء النهار
 لوحة التحكم والمراقبة
 عينيّة للتحكّم البصري في

control of optical sound recording
10 deck
11 recording amplifier and mains power unit
12 control desk (control console)
13 monitoring loudspeaker (control loudspeaker)
14 recording level indicators
15 monitoring instruments
16 jack panel
17 control panel
18 sliding control
19 equalizer
20 magnetic sound deck
21 mixer for magnetic film
22 film projector
23 recording and playback equipment
24 film reel (film spool)
25 head support assembly for the recording head, playback head, and erase head
26 film transport mechanism
27 synchronizing filter
28 magnetic sound amplifier
29 control panel
30 film-processing machines (film-developing machines) in the processing laboratory (film laboratory, motion picture laboratory)
31 echo chamber
32 echo chamber loudspeaker
33 echo chamber microphone
34-36 sound mixing (sound dubbing, mixing of several sound tracks)
34 mixing room (dubbing room)
35 mixing console (mixing desk) for mono or stereo sound
36 dubbing mixers (recording engineers, sound recordists) dubbing (mixing)
37-41 synchronization

التحكم الصوتي
 رفوف
 مجسّم صوتي
 وحدة الطاقة الرئيسيّة
 وحدة التحكم
 مكثف الصوت
 مؤشرات مستوى تسجيل الصوت
 الأداة المقاييس
 لوحة المقاييس
 لوح التحكم
 زر تحكّم انزلاقي
 الموازن
 جهاز الصوت المغناطيسي
 جهاز مكساج الفيلم المغناطيسي
 بروجكتور الفيلم
 معدات التسجيل والاستماع
 بكرّة الفيلم
 مجموعة حامل رؤوس التسجيل والاستماع والمنسح
 آلية نقل الفيلم
 مرشّح تزامني
 مجسّم صوت مغناطيسي
 لوحة تحكّم
 معدات معالجة الفيلم في معمل معالجة الأفلام
 غرفة الصدى
 مكبر صوت غرفة الصدى
 ميكروفون غرفة الصدى
الدوبلاج (مزج الأصوات)
 حجّرة الدوبلاج
 كونسول دبلجة الصوت العادي أو المجسّم
 مهندسو الدوبلاج

التحكم الصوتي
 وحدة المقاييس
 لوح التحكم
 موازن
 جهاز الصوت المغناطيسي
 جهاز مكساج الفيلم المغناطيسي
 بروجكتور الفيلم
 معدات التسجيل والاستماع
 بكرّة الفيلم
 مجموعة حامل رؤوس التسجيل والاستماع والمنسح
 آلية نقل الفيلم
 مرشّح تزامني
 مجسّم صوت مغناطيسي
 لوحة تحكّم
 معدات معالجة الفيلم في معمل معالجة الأفلام
 غرفة الصدى
 مكبر صوت غرفة الصدى
 ميكروفون غرفة الصدى
الدوبلاج (مزج الأصوات)
 حجّرة الدوبلاج
 كونسول دبلجة الصوت العادي أو المجسّم
 مهندسو الدوبلاج
الدبلجة

(syncing, dubbing, post-synchronization, post-syncing)
37 dubbing studio (dubbing theatre, *Am.* theater)
38 dubbing director
39 dubbing speaker (dubbing actress)
40 boom microphone
41 microphone cable
42-46 cutting (editing)
42 cutting table (editing table, cutting bench)
43 film editor (cutter)
44 film turntables for picture and sound tracks
45 projection of the picture
46 loudspeaker
312 Films (Motion Pictures) III
1-23 film projection (motion picture projection)
1 cinema (picture house, *Am.* movie theater, movie house)
2 cinema box office (*Am.* movie theater box office)
3 cinema ticket (*Am.* movie theater ticket)
4 usherette
5 cinemagoers (film-goers, cinema audience, *Am.* movie-goers, movie audience)
6 safety lighting (emergency lighting)
7 emergency exit
8 stage
9 rows of seats (rows)
10 stage curtain (screen curtain)
11 screen (projection screen)
12 projection room (projection booth)
13 lefthand projector
14 righthand projector
15 projection room window with projection window and observation port
16 reel drum (spool box)
17 house light dimmers

إضاءة ذور العَرْض
 مَقوم التيار المتردد
 مُضخّم الصوت
 فني أجهزة العرض
 طاولة لفّ الفيلم إلى بدايته
 مادة لاصقة للأفلام
 جهاز عَرْض السلايدات الخاص بالإعلانات
 أجهزة عرض الفيلم
 جهاز عرض الصوت
 أسطوانتا البركتين المقاومتان للحريق المزوّدتان بنظام تبريد زبتي
 ضرس التلقيح
 ضرس التقاط الفيلم
 عنقود الرأس المغناطيسي
 دولفين دليلي ذو تحكّم إيطاري
 آلية تشكيل أنشوطية لسوية الحركة المُتعلّقة، أيضا
 جهاز كُتف انقطاع الفيلم
 سنار الفيلم
 بكرّة الفيلم
 لفافة الفيلم
 بوابة فيلم معرّوثة تبريد
 سنار الفيلم
 بكرّة الفيلم
 لفافة الفيلم
 بوابة فيلم معرّوثة تبريد
 عدسات جهاز العَرْض
 محوّر تلقيح دَوّار
 محوّر التقاط الفيلم ذو إدارة احتكاكية
 آلية صليب مالطة
 مبيت المضباح
 مضباح قوسي ذو مرآة لائزرية مقعّرة ومغناطيس لتثبيت القوس (مضباح زينوون قوي عالي الضغط)

pressure xenon arc lamp)
40 positive carbon (positive carbon rod)
41 negative carbon (negative carbon rod)
42 arc
43 carbon rod holder
44 crater (carbon crater)
45 optical sound unit [also designed for multi-channel optical stereo-phonetic sound and for push-pull sound tracks]
46 sound optics
47 sound head
48 exciter lamp in housing
49 photocell in hollow drum
50 attachable four-track magnetic sound unit (penthouse head, magnetic sound head)
51 four-track magnetic head
52 narrow-gauge (*Am.* narrow-gage) cinema projector for mobile cinema
313 Films (Motion Pictures) IV
1-39 motion picture cameras (film cameras)
1 standard-gauge (*Am.* standard-gage) motion picture camera (standard-gauge, *Am.* standard gage, 35 mm camera)
2 lens (object lens, taking lens)
3 lens hood (sunshade) with matte box
4 matte (mask)
5 lens hood barrel
6 viewfinder eyepiece
7 eyepiece control ring
8 opening control for the segment disc (disk) shutter
9 magazine housing
10 slide bar for the lens hood
11 control arm (control lever)
12 pan and tilt head
13 wooden tripod

مضيب كربون موجب
 قضيب كربون سالب
 قوس
 حامل قضيب الكربون
 حفرة الكربون
 وحدة الصوت الضوئي (ممصمة) أيضا للصوت الجسم البصري متعدد القنوات ولمسارات الصوت
 بصريات صوتية
 رأس صوتي
 مضباح مُستثير في مبيته
 خلية كهروضوئية في أسطوانة حَجوفة
 وحدة صوت مغناطيسية ذات أربعة مسالك قابلة للفصل والتركيب
 رأس مغناطيسي ذات أربع مسارات
 جهاز عَرْض سينمائي ذو مقياس ضيق للسينما المتنقلة
الأفلام السِينمائيّة (3)
 دار السينما (الخيالة)
 شباك التذاكر
 تذكرة السينما
 دليل النظارة إلى مقاعدهم زائر السينما
 ضوء مَحْرَج الطوارئ
 مَحْرَج الطوارئ
 مسرح
 صفوف من المقاعد
 ستارة المسرح (ستارة الشاشة)
 شاشة (شاشة العرض)
 حَجيرة إسقاط الفيلم على الشاشة
 جهاز الإسقاط الأيسر
 جهاز الإسقاط الأيمن
 نافذة حَجيرة الإسقاط ذات نافذة الإسقاط وكوة المراقبة
 علبة بكرّة الفيلم
 أجهزة التحكم في خُفت

depreciate
 soundproof (blimped) motion picture camera (film camera)
16-18 soundproof housing (blimp)
16 upper section of the soundproof housing
17 lower section of the soundproof housing
18 open sidewall of the soundproof housing
19 camera lens
20 lightweight professional motion picture camera
21 grip (handgrip)
22 zooming lever
23 zoom lens (variable focus lens, varifocal lens) with infinitely variable focus
24 handgrip with shutter release
25 camera door
26 sound camera (news-reel camera) for recording sound and picture
27 soundproof housing (blimp)
28 window for the frame counters and indicator scales
29 pilot tone cable (sync pulse cable)
30 pilot tone generator (signal generator, pulse generator)
31 professional narrow-gauge (*Am.* narrow-gage) motion picture camera, a 16 mm camera
32 lens turret (turret head)
33 housing lock
34 eyecup
35 high-speed camera, a special narrow-gauge (*Am.* narrow-gage) camera
36 zooming lever
37 rifle grip
38 handgrip with shutter release
39 lens hood bellows
314 Ballet
1-6 the five positions

44 director's script (producer's script)	نص المخرج (نص المنتج)
45 stage carpenter	نجار المسرح
46 stagehand (scene shifter)	مبدل المناظر
47 set piece	قطعة منظر
48 mirror spot (mirror spotlight)	ضوء كاشف مزود بمرآة
49 automatic filter change (with colour filters, colour mediums, gels)	تغيير مرشحات آلي (مع فلترات وأوساط الألوان والهلامين)
50 hydraulic plant room	حجرة الوحدة الهيدروليكية
51 water tank	خزان ماء
52 suction pipe	أنبوب ماص
53 hydraulic pump	مضخة هيدروليكية
54 pressure pipe	أنبوب ضغط
55 pressure tank (accumulator)	خزان ضغط
56 pressure gauge (Am. gage)	مقياس الضغط
57 level indicator (liquid level indicator)	مؤشر مستوى السائل
58 control lever	ذراع التحكم
59 operator	مشغل
60 rams	مكسنا المضخة
317 Discotheque	صالة الديسكو
1 bar	البار
2 barmaid	ساقية البار
3 bar stool	مقعّد البار
4 shelf for bottles	رفّ الزجاجات
5 shelf for glasses	رفّ الأكواب
6 beer glass	كوب الجعة
7 wine and liqueur glasses	أكواب الخمر والمُسكِرات
8 beer tap (tap)	صنبور الجعة
9 bar	بار
10 refrigerator (fridge, Am. icebox)	ثلاجة
11 bar lamps	مصابيح البار
12 indirect lighting	إضاءة غير مباشرة
13 colour (Am. color) organ (clavilux)	أرغن ملون
14 dance floor lighting	إضاءة أرضية المرقص
15 speaker (loudspeaker)	مكبر صوت
16 dance floor	أرضية المرقص
17-18 dancing couple	شفاثي يرقصان
17 dancer	راقصة
18 dancer	راقص
19 record player	جهاز تشغيل الأسطوانات
20 microphone	ميكروفون
21 tape recorder	مسجل شرائط
22-23 stereo system (stereo equipment)	نظام تسجيل الصوت
22 tuner	جهاز الضبط الدقيق
23 amplifier	مضخم الصوت
24 records (discs)	أسطوانات (أقراص)
25 disc jockey	مشغل الأسطوانات (دي جي)

26 mixing console (mixing desk, mixer)	كوسول الممّج
27 tambourine	رقّ، نقّ صغير
28 mirrored wall	حائط مكوّن بالمرآيات
29 ceiling tiles	قرميد السقف
30 ventilators	فتحات التهوية
31 toilets (lavatories, WC)	دورات المياه
32 long drink	كأس طويلة للشراب
33 cocktail (Am. highball)	كوكتيل

318 Nightclub	المهلّي الليلي
1-33 nightclub (night spot)	المهلّي الليلي
1 cloakroom (Am. check-room)	غرفة إيداع القبعات والمعاطف
2 cloakroom attendant (Am. checkroom attendant)	عامل غرفة إيداع القبعات والمعاطف
3 band	فرقة موسيقية
4 clarinet	كلارينيت
5 clarinetist (Am. clarinetist)	عازف الكلارينيت
6 trumpet	الترّيق
7 trumpeter	عازف البوق
8 guitar	الجيتار
9 guitarist (guitar player)	عازف الجيتار
10 drums	الطبلة
11 drummer	عازف الطبلة
12 speaker (loudspeaker)	مكبر صوت
13 bar	البار
14 barmaid	ساقية البار
15 bar	بار
16 bar stool	مقعّد البار
17 tape recorder	جهاز تسجيل
18 receiver	مستقبل
19 spirits	مشروبات روحية
20 cine projector for porno films (sex films, blue movies)	جهاز عرض سينمائي للأفلام الجنسية
21 box containing screen	صندوق يحتوي على شاشة
22 stage	مسرح
23 stage lighting	إضاءة المسرح
24 spotlight	ضوء كاشف
25 festoon lighting	إضاءة فسطنونية
26 festoon lamp (lamp, light bulb)	مصباح فسطنوني
27-32 striptease act (striptease number)	رقصة التجرد من الملابس (الاستربتيز)
27 striptease artist (stripper)	راقصة الاستربتيز
28 suspender (Am. garter)	حذاء
29 brassière (bra)	صدريّة الثديين
30 fur stole	دثار من الفرو
31 gloves	قفازان
32 stocking	جورب نسائي
33 hostess	النادلة، المضيفة

319 Bullfighting, Rodeo	مصارعة الثيران
1-33 bullfight (corrida,	مصارعة الثيران

corrida de toros)	مصارعة ثيران زائفة
1 mock bullfight	مصارعة ثيران زائفة
2 novice (aspirant matador, novillero)	متعلم، متدرب
3 mock bull (dummy bull)	ثور زائف
4 novice banderillero (apprentice banderillero)	مصارع ثيران تحت التدريب
5 bullring (plaza de toros) [diagram]	حلبة مصارعة الثيران
6 main entrance	[رسم تخطيطي]
7 boxes	المُدخل الرئيسي
8 stands	مقصورات
9 arena (ring)	حلبة
10 bullfighters' entrance	مدخل مصارع الثيران
11 torril door	باب دخول الثور إلى الحلبة
12 exit gate for killed bulls	باب خروج الثيران القتيلة
13 slaughterhouse	المجزر
14 bull pens (corrals)	حظائر الثيران
15 paddock	اصطبل عرض الثيران قبل تباريها
16 lancer on horseback (picador)	رمّاح يمتطي سموة الحصان
17 lance (pike, pole, javelin)	رمح
18 armoured (Am. armored) horse	حصان مودّع
19 leg armour (Am. armor)	درع الساق
20 picador's round hat	قبعة البيكادور المستديرة
21 banderillo, a torero	مصارع الثيران
22 banderillas (barbed darts)	سهام مزينة
23 shirtwaist	بلوزة تصل إلى الخصر
24 bullfight	مصارعة الثيران
25 matador (swordsmen), a torero	الماتادور، مصارع الثيران
26 queue, a distinguishing mark of the matador	ضفيرة، علامة مميزة للمصارع
27 red cloak (capa)	عباءة حمراء
28 fighting bull	ثور المصارعة
29 montera [hat made of tiny black silk chenille balls]	المونيتيرا [قبعة مصنوعة من كريات صغيرة من الحرير الأسود]
30 killing the bull (kill, estocada)	قتل الثور
31 matador in charity performances [without professional uniform]	الماتادور في عروض خيرية [بدون الزي الرسمي]
32 estoque (sword)	سيف
33 muleta	عباءة (الموليّتا)
34 rodeo	الروديو
35 young bull	ثور صغير
36 cowboy	رامي البقر
37 stetson (stetson hat)	قبعة رامي البقر
38 scarf (necktie)	منديل، رباط عنق
39 rodeo rider	فارس الروديو
40 lasso	وهق حبل في طرفه أنشطة

320 Musical Notation

الفنونات الموسيقية

1	الموسيقى
1-2 medieval (medieval)	الموسيقى الفروسية
notes	النوتة
1 plainsong notation (neumes, neums, pneumes, square notation)	النوتة المسطحة
2 mensural notation	النوتة العنقودية
3-7 musical note (note)	النوتة الموسيقية
3 note head	رأس النوتة
4 note stem (note tail)	ذيل النوتة
5 hook	خطاف
6 stroke	شرطية
7 dot indicating augmentation of note's value	نقطة تفيد مضاعفة قيمة النوتة
8-11 clefs	المفاتيح
8 treble clef (G-clef, violin clef)	مفتاح "صول"
9 bass clef (F-clef)	مفتاح "فا"
10 alto clef (C-clef)	مفتاح "دو" (التو)
11 tenor clef	مفتاح تينور
12-19 note values	قيم النوتات
12 breve (brevis, Am. double-whole note)	نوتة بسرعة مضاعفة
13 semibreve (Am. whole note)	[المستديرة] نوتة بقيمة "روند"
14 minim (Am. half note)	[البضواء] نوتة بقيمة "بلاش"
15 crotchet (Am. quarter note)	[السوداء] نوتة بقيمة "نوار"
16 quaver (Am. eighth note)	[ذات السن] نوتة بقيمة "كروش"
17 semiquaver (Am. sixteenth note)	[ثلاثية الأسنان] نوتة بقيمة "دوبل كروش"
18 demisemiquaver (Am. thirty-second note)	[رباعية الأسنان] نوتة بقيمة "تربل كروش"
19 hemidemiquaver (Am. sixty-fourth note)	بقيمة "كوادربل كروش"
20-27 rests	راحة، سكتة
20 breve rest	سكتة موجزة
21 semibreve rest (Am. whole rest)	سكتة بقيمة "روند" [الراحة]
22 minim rest (Am. half rest)	سكتة بقيمة "بلاش" [نصف الراحة]
23 crotchet rest (Am. quarter rest)	سكتة بقيمة "نوار" [زمن التنفس]
24 quaver rest (Am. eighth rest)	سكتة بقيمة "كروش" [نصف زمن التنفس]
25 semiquaver rest (Am. sixteenth rest)	سكتة بقيمة "دوبل كروش" [رابع زمن التنفس]
26 demisemiquaver rest (Am. thirty-second rest)	سكتة بقيمة "تربل كروش" [اللميحة]
27 hemidemiquaver rest (Am. sixty-fourth rest)	سكتة بقيمة "كوادربل كروش" [الومضة]
28-42 time (time signatures, measure, Am. meter)	الميزان، دليل الميزان

28 two-eight time	ميزان 2-8	59 E major (C sharp minor)	"مي" كبير "لا" زائدة صغير	(inverted mordent, pralltriller)	pipes, syrnix)
29 two-four time	ميزان 4-2	60 B major (G sharp minor)	"سي" كبير "صول" زائدة صغير	20 lower mordent (mordent)	3 aulos, a double shawm آلة الشؤم الخشبية المزدوجة
30 two-two time	ميزان 2-2	61 F sharp major (D sharp minor)	"فا" زائدة كبير "ري" صغير	21 turn	4 aulos pipe مرمّار آلة الشؤم
31 four-eight time	ميزان 8-4	62 C major (A minor)	"دو" كبير "لا" صغير	22 arpeggio	5 phorbeia (peristomion, capistrum, mouth band)
32 four-four time (common time)	ميزان 4-4 (الميزان العادي)	63 F major (D minor)	"فا" كبير "ري" صغير	23-26 other signs in musical notation	6 crumhorn (crummhorn, cromorne, krumbhorn, krummhorn)
33 four-two time	ميزان 2-4	64 B flat major (G minor)	"سي" ناقصة كبير "صول" صغير	23 triplet: corresponding groupings: duplet (couplet), quadruplet, quintuplet, sextolet (sextuplet), septolet (septuplet, septimole)	7 recorder (fipple flute)
34 six-eight time	ميزان 8-6	65 E flat major (C minor)	"مي" ناقصة كبير "دو" صغير	24 tie (bind)	8 bagpipe; sim.: musette
35 six-four time	ميزان 6-4	66 A flat major (F minor)	"لا" ناقصة كبير "فا" صغير	25 pause (pause sign)	9 bag
36 three-eight time	ميزان 8-3	67 D flat major (B flat minor)	"ري" ناقصة كبير "سي" ناقصة صغير	27 marcato (marcando, markiert, attack, strong accent)	10 chanter (melody pipe)
37 three-four time	ميزان 4-3	68 G flat major (E flat minor)	"صول" ناقصة كبير "مي" ناقصة صغير	28 presto (quick, fast)	11 drone (drone pipe)
38 three-two time	ميزان 2-3	321 Musical Notation II	التؤنات الموسيقية (2)	29 portato (lourer, mezzo staccato, carried)	12 curved cornet (zink)
39 nine-eight time	ميزان 8-9	1-5 chord	اختلاف	30 tenuto (held)	13 serpent
40 nine-four time	ميزان 4-9	1-4 triad	مثلث	31 crescendo (increasing gradually in power)	14 shawm (schalmeyes); larger: bombard (bombarde, pommer)
41 five-four time	ميزان 4-5	1 major triad	مثلث كبير	32 decrescendo (diminuendo, decreasing or diminishing gradually in power)	15 cythara (cithara); sim. and smaller: lyre
42 bar (bar line, measure line)	حاجز	2 minor triad	مثلث صغير	33 legato (bound)	16 arm
43-44 staff (stave)	المدرّج	3 diminished triad	مثلث مصحوم	34 staccato (detached)	17 bridge
43 line of the staff	خط المدرّج	4 augmented triad	مثلث مضاف	35 piano (soft)	18 sound box (resonating chamber, resonator)
44 space	فراغ	5 chord of four notes, ■ chord of the seventh (seventh chord, dominant seventh chord)	اختلاف من أربع نغمات (اختلاف سباعي)	36 pianissimo (very soft)	19 plectrum, a plucking device
45-49 scales	المسلم	6-13 intervals	الفواصل	37 pianissimo piano (as soft as possible)	20 kit (pochette), a miniature violin
45 C major scale naturals: c, d, e, f, g, a, b, c	علامات السلم "دو" الكبير دو، ري، مي، فا، صول، لا، س، دو	6 unison (unison interval)	تطابق النغمات	38 forte (loud)	21 cittern (cithern, cither, cister, citole), a plucked instrument; sim.: pandora (bandora, a bandore)
46 A minor scale [natural] naturals: a, b, c, d, e, f, g, a	علامات السلم الصغير "لا" لا، سي، دو، ري، مي، فا، صول، لا	7 major second	ثنائي كبير، مسافة صوتية	39 fortissimo (very loud)	22 sound hole
47 A minor scale [harmonic]	سلم "لا" الصغير [توافقي]	8 major third	ثلاثي كبير، مسافة صوتية	40 forte fortissimo (double fortissimo, as loud as possible)	23 viol (descant viol, treble viol, a viola da gamba); larger: tenor viol, bass viol (viola da gamba, gamba), violone (double bass viol)
48 A minor scale [melodic]	سلم "لا" الصغير [لحني]	9 perfect fourth	رباعي تام، مسافة صوتية رباعية تامة	41 forte piano (loud and immediately soft again)	24 viol bow
49 chromatic scale	سلم ملون	10 perfect fifth	خماسي تام، مسافة صوتية خماسية تامة	42-50 divisions of the compass	25 hurdy-gurdy (vielle à roue, symphonia, armonie, organistrum)
50-54 accidentals (inflections, key signatures)	علامات تحويل النغمة عرضياً	11 major sixth	سداسي كبير، مسافة صوتية سداسية كبيرة	42 subcontra octave (double contra octave)	26 friction wheel
50-51 signs indicating the raising of a note	علامات رفع النغمة	12 major seventh	سباعي كبير، مسافة صوتية سباعية كبيرة	43 contra octave	27 wheel cover (wheel guard)
50 sharp (raising the note a semitone or half-step)	علامة الزيادة (رفع النغمة نصف درجة)	13 perfect octave	ثماني تام، مسافة صوتية ثماني تام	44 great octave	28 keyboard (keys)
51 double sharp (raising the note a tone or full-step)	علامة الزيادة مرتين (رفع النغمة درجة كاملة)	14-22 ornaments (graces, grace notes)	الزخارف (التوافل)	45 small octave	29 resonating body (resonator, sound box)
52-53 signs indicating the lowering of a note	علامات خفض النغمة	14 long appoggiatura	نافلة طويلة	46 one-line octave	30 melody strings
52 flat (lowering the note a semitone or half-step)	علامة التقيص (خفض النغمة نصف درجة)	15 acciacatura (short appoggiatura)	نافلة قصيرة	47 two-line octave	31 drone strings (drones, bourdons)
53 double flat (lowering the note a tone or full-step)	علامة التقيص مرتين (خفض النغمة درجة كاملة)	16 slide	انزلاق	48 three-line octave	32 dulcimer
54 natural	[علامة الغناء] علامة الطبيعية	17 trill (shake) without turn	زغردة بدون التفاف	49 four-line octave	33 rib (resonator wall)
55-68 keys (major keys and the related minor keys having the same signature)	المفاتيح (المفاتيح الكبيرة والمفاتيح الصغيرة المرتبطة بها ولها نفس الدليل)	18 trill (shake) with turn	زغردة بالتفاف	50 five-line octave	34 beater for the Valasian dulcimer
55 C major (A minor)	"دو" كبير "لا" صغير	19 upper mordent	زغردة قصيرة علوية	322 Musical Instruments I	1 lur, a bronze trumpet
56 G major (E minor)	"صول" كبير "مي" صغير			2 panpipes (Pandeon)	قانون، سنطير، سنطور
57 D major (B minor)	"ري" كبير "سي" صغير				خلع (جدار الرنين)
58 A major (F sharp minor)	"لا" كبير "فا" زائدة صغير				أداة عزف القانون الفالسي

11 tuning peg (peg, lute pin)	ملوي الدوزنة
12 guitar	جيتار
13 string holder	مشط تثبيت الأوتار
14 string, a gut (catgut) or nylon string	وتر
15 resonating body (resonating chamber, resonator, sound box)	صندوق الصوت، جسم الرنين
16 mandolin (mandoline)	ماندولين
17 sleeve protector (cuff protector)	وقاء الكم
18 neck	عنق
19 pegdisc	قرص الملوي
20 plectrum	ريشة العازف
21 zither (plucked zither)	القانون
22 pin block (wrest pin block, wrest plank)	لوحة مفاتيح ضبط الأوتار
23 tuning pin (wrest pin)	مفتاح الضبط
24 accompaniment strings (bass strings, unfretted strings, open strings)	أوتار مصاحبة
25 melody strings (fretted strings, stopped strings)	أوتار الألحان
26 semicircular projection of the resonating sound box (resonating body)	صندوق صوت نصف دائري
27 ring plectrum	ريشة عزف حلقيّة
28 balalaika	البالاكية
29 banjo	البيانجو
30 tambourine-like body	جسم شبيه بالدف (الرق)
31 parchment membrane	رق من البرشمان
32 ocarina, a globular flute	الأكرينة
33 mouthpiece	قطعة الفم، الميمس
34 fingerhole	فتحة الأصابع
35 mouth organ (harmonica)	الهرمونيك
36 accordion; sim.: piano accordion, concertina, bandoneon	الأكورديون
37 bellows	مشط الأكورديون
38 bellows strap	سيز المشط
39 melody side (keyboard side, melody keys)	جانب مفاتيح الألحان
40 keyboard (keys)	لوحة المفاتيح
41 treble stop (treble coupler, treble register)	آلية إيقاف السوبرانو
42 stop lever	ذراع ضبط الأنابيب في الأكورديون
43 bass side (accompaniment side, bass studs, bass press-studs, bass buttons)	جانب الباص (أزرار الباص)
44 bass stop (bass coupler, bass register)	آلية إيقاف الباص
45 tambourine	الرق
46 castanets	صنّاجات
47-78 jazz band	آلات فريق الجاز

ماسك الإصبع	45 thumb hold
ترومبون [المتردة]	46 trombone; kinds: alto trombone, tenor trombone, bass trombone
التو، ترومبون تينور، ترومبون باص	47 trombone slide (slide)
منزلة الترومبون	48 bell
طرف جرسى الشكل	49-59 percussion instruments
آلات القرقع	49 triangle
المثث	50 cymbals
صنوج	51-59 membranophones
الآلات الغشائية	51 side drum (snare drum)
طبل مطوق، طبل جانبي صغير	52 drum head (head, upper head, batter head, vellum)
رأس الطبل	53 tensioning screw
برغي شد الغشاء	54 drumstick
عصا الطبل	55 bass drum (Turkish drum)
طبل قراري	56 stick (padded stick)
عصا مطبقة	57 Kettledrum (timpano), a screw-tensioned drum; sim.: machine drum (mechanically tuned drum)
نقاريات	58 kettledrum skin (kettledrum vellum)
جلد/غشاء النقاريات	59 tuning screw
برغي الضبط	60 harp, a pedal harp
هارب، هارب ذو دواسة	61 strings
أوتار	62 pedal
دواسة	

قوس الكمان	12 violin bow (bow)
صامولة	13 nut (frog)
عصا القوس	14 stick (bow stick)
شعر القوس	15 hair of the violin bow (horsehair)
فيولونسيل [الكمان الجهير]	16 violoncello (cello), a member of the da gamba violin family
رأس الكمان المعقوف	17 scroll
ملوي الدوزنة	18 tuning peg (peg)
صندوق الملوي	19 pegbox
صامولة	20 nut
لوح الأصابع	21 fingerboard
ملوي الذئيل	22 spike (tailpin)
كونتر باص (الكمان الأجهر)	23 double bass (contrabass, violone, double bass viol, Am. bass)
لوحة الصوت	24 belly (top, soundboard)
ضلع (جدار جانبي)	25 rib (side wall)
ترصيع، تطعيم	26 purfling (inlay)
فيولا [الكمان الأوسط]	27 viola
آلات نفخية خشبية	28-38 woodwind instruments (woodwinds)
باسون [الزّمخر] الكبير	28 bassoon; larger: double bassoon (contrabassoon)
كونتر باسون	29 tube with double reed
أنبوب ذو مرّارين	30 piccolo (small flute, piccolo flute, flauto piccolo)
بيكولو (سرناي)	31 flute (German flute), a cross flute (transverse flute, side-blown flute)
فلوت (ناي افرنجية)	32 key
مفتاح	33 fingerhole
فتحة الاصبع	34 clarinet; larger: bass clarinet
الكلارينيت، الأكبر حجماً	35 key (brille)
الكلارينيت باص	36 mouthpiece
مفتاح	37 bell
قطعة الفم (الميمس)	38 oboe (hautboy); kinds: oboe d'amore; tenor oboes: oboe da caccia, cor anglais; heckelphone (baritone oboe)
طرف الكلارينيت المتسع (جرسي الشكل) أبوا	39-48 brass instruments
الآلات النحاسية	39 tenor horn
بوق تينور	40 valve
صمام	41 French horn (horn, waldhorn), valve horn
بوق فرنسي	42 bell
طرف جرسى الشكل	43 trumpet; larger: Bb cornet; smaller: cornet
ترامبيت، الأكبر كورته	44 bass tuba (tuba, bombardon); sim.: helicon (pellitone), contrabass
سي، الأصغر كورنه	
توبا، توبا كونتر باص	

مقرعة القانون الإبنزلي	35 hammer (stick) for the Appenzel dulcimer
كلافيكورد، أنواعه ذو عتب أو بدون عتب	36 Clavichord; kinds: fretted or unfretted clavichord
آلية عمل الكلافيكورد	37 clavichord mechanism
مفتاح	38 key (key lever)
قصب توازن	39 balance rail
لسان دليبي	40 guiding blade
شفة دليلية	41 guiding slot
قصب إسناد	42 resting rail
قطعة مماس	43 tangent
وتر	44 string
الهاربسيكورد، السينيت، بيان صغير	45 harpsichord (clavichord, cembalo), a wing-shaped stringed keyboard instrument; sim.: spinet (virginal)
لوحة المفاتيح العلوية	46 upper keyboard (upper manual)
لوحة المفاتيح السفلية	47 lower keyboard (lower manual)
آلية عمل الهاربسيكورد	48 harpsichord mechanism
مفتاح	49 key (key lever)
عود	50 jack
قطعة منزقة	51 slide (register)
لسان	52 tongue
ريشة عاجية لنقر الوتر	53 quill plectrum
دواسة منع اهتزاز الأوتار	54 damper
وتر	55 string
أرغن نقالي	56 portable organ, a portable organ; larger: positive organ (positive)
مصنّار	57 pipe (flue pipe)
مفتاح الأرغن	58 bellows

آلات الأوركسترا	323 Musical Instruments II
آلات الأوركسترا	1-62 orchestral instruments
آلات وترية	1-27 stringed instruments, bowed instruments
الكمان	1 violin
عنق الكمان	2 neck of the violin
جسم الكمان	3 resonating body (violin body, sound box of the violin)
ضلع (الجدار الجانبي)	4 rib (side wall)
مشط الكمان	5 violin bridge
فتحة علي شكل F	6 F-hole, a sound hole
قطعة الذئيل	7 tailpiece
مسند ذقن العازف	8 chin rest
أوتار الكمان وتر "صول"	9 strings (violin strings, fiddle strings): G-string, D-string, A-string, E-string
وتر "ري" وتر "لا" وتر "مي"	
مخفات	10 mute (sordino)
راتج القفونية	11 resin (rosin, colophony)

35 hammer (stick) for the Appenzel dulcimer	مقرعة القانون الإبنزلي
36 Clavichord; kinds: fretted or unfretted clavichord	كلافيكورد، أنواعه ذو عتب أو بدون عتب
37 clavichord mechanism	آلية عمل الكلافيكورد
38 key (key lever)	مفتاح
39 balance rail	قصب توازن
40 guiding blade	لسان دليبي
41 guiding slot	شفة دليلية
42 resting rail	قصب إسناد
43 tangent	قطعة مماس
44 string	وتر
45 harpsichord (clavichord, cembalo), a wing-shaped stringed keyboard instrument; sim.: spinet (virginal)	الهاربسيكورد، السينيت، بيان صغير
46 upper keyboard (upper manual)	لوحة المفاتيح العلوية
47 lower keyboard (lower manual)	لوحة المفاتيح السفلية
48 harpsichord mechanism	آلية عمل الهاربسيكورد
49 key (key lever)	مفتاح
50 jack	عود
51 slide (register)	قطعة منزقة
52 tongue	لسان
53 quill plectrum	ريشة عاجية لنقر الوتر
54 damper	دواسة منع اهتزاز الأوتار
55 string	وتر
56 portable organ, a portable organ; larger: positive organ (positive)	أرغن نقالي
57 pipe (flue pipe)	مصنّار
58 bellows	مفتاح الأرغن

instruments (dance band instruments)	آلات القَرع	<i>smaller form:</i> cottage piano (pianino); <i>earlier forms:</i> pantaleon, celesta, with steel bars instead of strings	
47-54 percussion instruments	طاقم الطبل	2-18 piano action (piano mechanism)	آلية عمل البيانو
47 bass drum	طبل قُراري	2 iron frame	إطار معدني
48 small tom-tom	طبلية "توم توم" صغيرة	3 hammer; <i>collectively:</i> striking mechanism	مطرقة (جماعياً آلية القَرع)
49 large tom-tom	طبلية "توم توم" كبيرة	4-5 keyboard (piano keys)	لوحة المفاتيح
50 high-hat cymbals (choke cymbals, Charleston cymbals, cup cymbals)	صنوج "تشارلستون"	4 white key (ivory key)	مفتاح أبيض/عاج
51 cymbal	صنج	5 black key (ebony key)	مفتاح أسود/ابنوس
52 cymbal stand (cymbal holder)	حامل الصنج	6 piano case	صندوق البيانو
53 wire brush	فُرْشاة سلكية	7 strings (piano strings)	أوتار (أوتار البيانو)
54 pedal mechanism	آلية الدواسة	8-9 piano pedals	دواسة البيانو
55 conga drum (conga)	طبل تقارية، طبل الكونجا	8 right pedal (sustaining pedal, damper pedal; <i>loosely:</i> forte pedal, loud pedal) for raising the dampers	الدواسة اليسرى لتقليل مسافة قَرع المطارق على الأوتار
56 tension hoop	طوق شد الغشاء	9 left pedal (soft pedal; <i>loosely:</i> piano pedal) for reducing the striking distance of the hammers on the strings	الدواسة اليسرى لتقليل مسافة قَرع المطارق على الأوتار
57 timbales	تقارية، تمبال	10 treble strings	الأوتار عالية الطبقة
58 bongo drums (bongos)	البونجويز	11 treble bridge (treble belly bridge)	جسر الأوتار عالية الطبقة
59 maracas; <i>sim.:</i> shakers	القُرعية، ماراكاس	12 bass strings	أوتار الباص
60 guiro	الجيرو	13 bass bridge (bass belly bridge)	جسر أوتار الباص
61 Xylophone; <i>form.:</i> straw fiddle; <i>sim.:</i> marimbaphone (steel marimba), tubaphone	زَيْلوفون	14 hitch pin	مسمار ربط الأوتار
62 wooden slab	شريحة خشبية	15 hammer rail	قضيب المطارق
63 resonating chamber (sound box)	صندوق الصوت	16 brace	دعامة، شكال
64 beater	عصا قَرع الزَيْلوفون	17 tuning pin (wrest pin, tuning peg)	مسمار الدواسة
65 jazz trumpet	ترامبيت الجاز	18 pin block (wrest pin block, wrest plank)	لوحة مسامير الضبط
66 valve	صمام	19 metronome	مترونوم بتدول الإيقاع
67 finger hook	خَطاف الإصبع	20 tuning hammer (tuning key, wrest)	مفتاح الضبط/الدواسة
68 mute (sordino)	مخفّات	21 tuning wedge	إسفين الضبط/الدواسة
69 saxophone	سأكسوفون	22-29 key action (key mechanism)	آلية عمل المفاتيح
70 bell	طَرَف جرسي الشكل	22 beam	عارضة خشبية
71 crook	انحناف، انحناء	23 damper-lifting lever	ذراع رَفْع المِخفّات
72 mouthpiece	الميسم	24 felt-covered hammer head	رأس مطرقة مكسوة باللباد
73 struck guitar (jazz guitar)	جيتار الجاز	25 hammer shank	رجل المطرقة
74 hollow to facilitate fingering	تجويف لسهولة حركة الأصابع	26 hammer rail	قضيب المطرقة
75 vibraphone (<i>Am. vibra-harp</i>)	الفيفرافون	27 check (back check)	مخك
76 metal frame	إطار معدني	28 check felt (back check felt)	لبانة المخك
77 metal bar	قطعة معدنية	29 wire stem of the check (wire stem of the back check)	ساق المخك السلكية
78 tubular metal resonator	مرنان تضخم صوت معدني أنبوبي الشكل	30 sticker (hopper, hammer jack, hammer	مرفاع المطرقة

lever)	زرّ	10 pallet	سقالة
31 button	ألية التشغيل	11 wind trunk	خرطوم الهواء المضغوط
32 action lever	دليل	12-14 wind chest, a slider wind chest; <i>other types:</i> sliderless wind chest (unit wind chest), spring chest, kegellade chest (cone chest), diaphragm chest	صندوق الهواء المضغوط أنواع أخرى صندوق هواء مضغوط بدون منزلقة، صندوق بنايضي، صندوق مخروطي، صندوق رقمي
33 pilot	سلك الدليل	12 wind chest (wind chest box)	صندوق الهواء المضغوط
34 pilot wire	سلك الشريط	13 groove	أخدود
35 tape wire	شريط	14 upper board groove	أخدود اللوح العلوي
36 tape	المخفّات (كتلة المخفّات)	15 upper board	اللوح العلوي
37 damper (damper block)	ذراع رَفْع المِخفّات	16 pipe of a particular stop	مِزمار له مِقْبِض ضَبْط خاص
38 damper lifter	قضيب آستان المِخفّات	17-35 organ pipes (pipes)	مِزامير الأرغن
39 damper rest rail	بيانو أفقي/مربع	17-22 metal reed pipe (set of pipes: reed stop), a posauene stop	مِزمار معدني (مجموعة من المِزامير مضبب قصبات المِزامير)
40 grand piano (horizontal piano, grand, concert grand; <i>smaller:</i> baby grand piano, boudoir piano; <i>sim.:</i> square piano, table piano)		17 boot	غطاء واق
41 grand piano pedals: right pedal for raising the dampers; left pedal for softening the tone (shifting the keyboard so that only one string is struck 'una corda')	دواسة البيانو الأمامي الدواسة اليمنى لرفع المِخفّات؛ الدواسة اليسرى لترخيم النغمة	18 shallot	قفلو ط
42 pedal bracket	كتيفة الدواستان	19 tongue	لسان
43 harmonium (reed organ, melodion)	هارمونيوم	20 block	كتلة
44 draw stop (stop, stop knob)	مِقْبِض ضَبْط أنابيب الأرغن	21 tuning wire (tuning crook)	سلك الضبط
45 knee lever (knee swell, swell)	أداة ضَبْط حجم الصوت	22 tube	مِزمار
46 pedal (bellows pedal)	دواسة (دواسة بمفخاخ)	23-30 open metal flue pipe, a salicional	مِزمار معدني مفتوح ذو مجرى هوائي
47 harmonium case	صندوق آلة الهارمونيوم	23 foot	قدم
48 harmonium keyboard (manual)	لوحة مفاتيح آلة الهارمونيوم	24 flue pipe windway (flue pipe duct)	فتحة مرور الهواء بالمِزمار
326 Musical Instruments V	الآلات الموسيقية (5)	25 mouth (cutup)	فم
1-52 organ (church organ)	الأرغن (أرغن الكنيسة)	26 lower lip	شفة سفلى
1-5 front view of organ (organ case) [built according to classical principles]	منظر أمامي للأرغن [مصنوع طبقاً للمبادئ الكلاسيكية]	27 upper lip	شفة علوية
1-3 display pipes (face pipes)	مِزامير أمامية	28 languid	أداة تخفيف
1 Hauptwerk	الأرغن الكبير	29 body of the pipe (pipe)	جسم المِزمار
2 Oberwerk	الأرغن الضخم	30 tuning flap (tuning tongue), a tuning device	جهاز الضبط
3 pedal pipes	مِزامير الدواسة	31-33 open wooden flue pipe (open wood), principal (diapason)	مِزمار خشبي مفتوح ذو قناة هوائية (شوكه الدوّزان)
4 pedal tower	برج الدواسة	31 cap	غطاء
5 Rückpositiv	الريوكوزيتيف	32 ear	وذنّة
6-16 tracker action (mechanical action); <i>other systems:</i> pneumatic action, electric action	آلية التشغيل الميكانيكية: أنظمة أخرى تشغيل بالهواء المضغوط، تشغيل كهربائي	33 tuning hole (tuning slot), with slide	فتحة دواسة ذات قطعة منزلقة
6 draw stop (stop, stop knob)	مِقْبِض ضَبْط مِزامير الأرغن	34 stopped flue pipe	مِزمار ذو قناة هوائية بعد ضبطه
7 slider (slide)	قطعة منزلقة	35 stopper	أداة الضبط
8 key (key lever)	مفتاح (ذراع المفتاح)	36-52 organ console (console) of an electric action organ	كونسول أرغن كهربائي
9 sticker	مرفاع المطرقة	36 music rest (music stand)	منصة
		37 crescendo roller indicator	مؤشر تزايد الرفع تدريجياً
		38 voltmeter	فولتامتير
		39 stop tab (rocker)	ذراع مِقْبِض الضبط

40 free combination stud (free combination knob)	مِقْبَضٌ اثْنَلَا فَي حَر
41 cancel buttons for reeds, couplers etc.	أَزْرَارُ الإِلْغَاءِ الْخَاصَّةِ بِالْمَزَامِيرِ، الخ.
42 manual I, for the Rückpositiv	مِفْتَاحٌ 1 لِضَبْطِ "الرُّوكُوزِيْتِيْفِ" (أَرْغُنِ المَرْتَلِينِ بِالْكَنِيسَةِ)
43 manual II, for the Hauptwerk	مِفْتَاحٌ 2 لِضَبْطِ "أَلْهَابُوْبْتَرِك" "
44 manual III, for the Oberwerk	مِفْتَاحٌ 3 لِضَبْطِ "أَلْأَوْبَرْفَرِك" "
45 manual IV, for the Schwellwerk	مِفْتَاحٌ 4 لِضَبْطِ "أَلْشُوْبْلُفْرِك" "
46 thumb pistons controlling the manual stops (free or fixed combinations) and buttons for setting the combinations	صَمَاْمَاتُ الإِبْهَامِ لِتَحْكَمِ فِي تَوَقُّفَاتِ الْمَغَاتِيْحِ وَأَزَارِ ضَبْطِ الأَثْلَافَاتِ
47 switches for current to blower and action	مِفْتَاحِيْعُ تِيَارِ المِفْطَاحِ وَآلِيَةِ التَشْغِيْلِ
48 toe piston, for the coupler	صَمَاْمٌ إِصْبَعِ القَدَمِ لِآلِيَةِ القَارِنَةِ
49 crescendo roller (general crescendo roller)	أَسْطُوَانَةٌ التَّصَدُّعِ
50 balanced swell pedal	دَوَّاسَةٌ مِتَوَازِنَةٌ
51 pedal key [natural]	مِفْتَاحُ الدَّوَّاسَةِ [طَبِيْعِي]
52 pedal key [sharp or flat]	مِفْتَاحُ الدَّوَّاسَةِ [حَادٍ أَوْ نَاقِصٍ]
53 cable (transmission cable)	كَبِيْلٌ (كَبِيْلُ الإِرْسَالِ)
327 Fabulous Creatures (Fabled Beings)	المَخْلُوقَاتُ الخُرَافِيَّةُ (المَخْلُوقَاتُ الأَسْطُورِيَّةُ)
1-61 fabulous creatures (fabulous animals), mythical creatures	المَخْلُوقَاتُ الخُرَافِيَّةُ (المَخْلُوقَاتُ الأَسْطُورِيَّةُ)
1 dragon	التَّنْتِنُ
2 serpent's body	جِسْمُ ثَعْبَانٍ
3 claws (claw)	مَتْخَالِبُ
4 bat's wing	جَنَاحُ خَفَاشٍ
5 fork-tongued mouth	فَمٌ بِهَ لِسَانٍ مُشْعَبٌ
6 forked tongue	لِسَانٌ مُشْعَبٌ
7 unicorn [symbol of virginity]	أَحَادِي الْقُرْنِ [رَمْزٌ العَدْرِيَّةِ]
8 spirally twisted horn	قُرْنٌ مَلْفُوفٌ حَلْزُونِيًّا
9 Phoenix	العِقْءَاءُ
10 flames or ashes of resurrection	أَلْبَسَةٌ نُهَبٌ أَوْ رَمَادُ البَيْتِ
11 griffin (griffon, gryphon)	الْغُرْفِينُ
12 eagle's head	رَأْسُ نَسْرٍ
13 griffin's claws	مَتْخَالِبُ الْغُرْفِينِ
14 lion's body	جِسْمُ أَسَدٍ
15 wing	جَنَاحُ
16 chimera (chimaera), a	المَكْمِرُ

monster	رَأْسُ أَسَدٍ
17 lion's head	رَأْسُ عِزَّةٍ
18 goat's head	جِسْمُ بَيْتَيْنِ
19 dragon's body	أَبُو الهَوْلِ
20 sphinx, a symbolic figure	رَأْسُ أَدْمِي
21 human head	جِسْمُ أَسَدٍ
22 lion's body	حُورِيَّةُ المَاءِ، النَّارِيَّةُ حُورِيَّةُ البَحْرِ، الذَكَرُ مَكْسُ
23 mermaid (nix, nixie, water nixie, sea maid, sea maiden, naiad, water nymph, water elf, ocean nymph, sea nymph, river nymph); sim.: Nereids, Oceanids (sea divinities, sea deities, sea goddesses); male: nix (merman, seaman)	جِذْعُ امْرَأَةٍ ذَيْلُ سَمَكَةٍ (ذَيْلُ دَوْلْفِينِ)
24 woman's trunk	الْفَرَسُ المَجْتَمِعُ (بِيغَاسُوسُ) الْهِيْدِيُوْغَرِيْفُ
25 fish's tail (dolphin's tail)	جِسْمُ حِصَانٍ جَنَاحَانِ
26 Pegasus (favourite, Am. favorite, steed of the Muses, winged horse); sim.: hippogriff	سَيْرِيْبُوسُ (الْكَلْبُ الحَارِسُ لِبَابِ الجَيْمِ) جِسْمُ كَلْبٍ لَهُ ثَلَاثُ رُؤُوسِ
27 horse's body	ذَنْبُ ثَعْبَانٍ العُدَارُ
28 wings	جِسْمُ وَتَسَعِ رُؤُوسِ تَعَابِيْنِ
29 Cerberus (hellhound)	البَازِيْلِيْقُ رَأْسُ دِيْكٍ
30 three-headed dog's body	جِسْمُ بَيْتَيْنِ الْمَارِدُ
31 serpent's tail	صَخْرَةٌ قَدَمٌ عَلَى شَكْلِ ثَعْبَانٍ
32 Lernaean (Lernean) Hydra	تَرِيْتُونُ (أَحَدُ أَنْصَافِ آهَةِ البَحْرِ عِنْدَ الإِغْرِيقِ) بُوقٌ مِنْ صَدْفِ المَحَارِ
33 nine-headed serpent's body	حَافِرُ حِصَانٍ ذَيْلُ سَمَكَةٍ
34 basilisk (cockatrice)	مَارِدُ البَحْرِ
35 cock's head	جِذْعُ حِصَانٍ
36 dragon's body	ذَيْلُ سَمَكَةٍ
37 giant (titan)	تُورُ البَجْرِ
38 rock	جِسْمٌ وَحْشِيٌّ
39 serpent's foot	ذَيْلُ سَمَكَةٍ
40 triton, a merman (demigod of the sea)	بَيْتَيْنِ سِفْرَ الرُّؤْيَا لِلْقُدَيْسِ يُوحَنَّا ذُو السَّبْعِ رُؤُوسِ
41 conch shell trumpet	جِنَاحُ
42 horse's hoof	
43 fish's tail	
44 hippocampus	
45 horse's trunk	
46 fish's tail	
47 sea ox, a sea monster	
48 monster's body	
49 fish's tail	
50 seven-headed dragon of St. John's Revelation (Revelations, Apocalypse)	
51 wing	

52 centaur (hippocentaur), half man and half beast	القَلْبُورُ، نِصْفُ رَجُلٍ وَنِصْفُ وَحْشٍ
53 man's body with bow and arrow	جِسْمُ إِنْسَانٍ يَحْمِلُ قَوْسًا وَسَهْمًا
54 horse's body	جِسْمُ حِصَانٍ
55 harpy, a winged monster	الْخَطَافُ
56 woman's head	رَأْسُ امْرَأَةٍ
57 bird's body	جِسْمُ طَائِرٍ
58 siren, a daemon	السَّيْرَانَةُ، شَيْطَانٌ
59 woman's body	جِسْمُ امْرَأَةٍ
60 wing	جَنَاحُ
61 bird's claw	بَرْنَجُ طَائِرٍ
328 Prehistory 1-40 prehistoric finds	مَاقِبِلُ التَّأْرِخِ لِقَبَائِلِ تَعُوْدُ إِلَى مَا قَبِلُ التَّأْرِخِ العَصْرُ الحَجْرِي الْقَدِيْمُ وَالحَقِيْقَةُ المِيْزُولِثِيَّةُ
1-9 Old Stone Age (Palaeolithic, Paleolithic, period) and Mesolithic period	فَاسٌ يَدَوِيٌّ
1 hand axe (Am. ax) (fist hatchet), a stone tool	رَأْسُ رَمْعٍ مِصْرُوعٍ مِنْ العِظْمِ
2 head of throwing spear, made of bone	خَزْبُونٌ عَظْمِيٌّ
3 bone harpoon	رَأْسُ
4 head	قَائِظَةٌ حُرْبِيُونُ مِصْرُوعَةٌ مِنْ قَرْنِ الوَعْلِ
5 harpoon thrower, made of reindeer antler	حَصْوَةٌ مَلُوكَةٌ
6 painted pebble	رَأْسُ حِصَانٍ بَرِّيٍّ، رَأْسُ مَتْخُوتٍ
7 head of a wild horse, a carving	وَقْتُنٌ مِنَ العَصْرِ الحَجْرِيِّ، تَمَثَّالٌ صَغِيْرٌ مِنَ العَاجِ رَسْمُ البَيْسُونِ بِدَاخِلِ أَحَدِ الكَهْوَفِ [فَنُّ رَسْمِ الكَهْوَفِ]
8 Stone Age idol, an ivory statuette	العَصْرِ الحَجْرِي الحَدِيْدِ
9 bison, a cave painting (rock painting) [cave art, cave painting]	الْأَمْقُورَةُ قِصْعَةٌ خُرَافِيَّةٌ [مِجْمُوعَةٌ المَنْهِيْرِيْ] قَارُورَةٌ ذَاتُ عُنُقٍ
10-20 New Stone Age (Neolithic period)	العَصْرِ الحَجْرِي الحَدِيْدِ
10 amphora [corded ware]	الْأَمْقُورَةُ
11 bowl [menhir group]	قِصْعَةٌ خُرَافِيَّةٌ [مِجْمُوعَةٌ المَنْهِيْرِيْ] قَارُورَةٌ ذَاتُ عُنُقٍ
12 collared flask [Funnel-Beaker culture]	إِنَاءٌ ذُو خَارْفَرٍ لَوْلِيَّةِيَّةِ الشَّكْلِ
13 vessel with spiral pattern [spiral design pottery]	سَمَكُنٌ يَرْتَفِعُ عَلَى عِضَادَاتٍ، سَمَكُنٌ بَحْرِيٌّ
14 bell beaker [bell beaker culture]	الدَوْلْمُنُ، قَبْرٌ مِجَالِيْتِيٌّ
15 pile dwelling (lake dwelling, lacustrine dwelling)	أَنْوَاعُهُ مَمْرِيٌّ وَهَيْلِيْكِيٌّ، إِذَا كَانَ مَعْطًى بِالتَّرَابِ فَهُوَ جَنْشُورَةٌ
16 dolmen (cromlech), a megalithic tomb (coll.: giant's tomb); other kinds: passage grave, gallery grave (long cist); when covered with earth: tumulus	

(barrow, mound)	ضَرِيْحُ حَجْرِيٍّ
17 stone cist, a contracted burial	الْمَنْهِيْرُ نُصْبٌ حَجْرِيٌّ عَمُودِيٌّ
18 menhir (standing stone), a monolith	فَاسٌ حَجْرِيٌّ لِلْقِتَالِ
19 boat axe (Am. ax), a stone battle axe	وَقْتُنٌ مِنَ الصِّلْصَالِ
20 clay figurine, an idol	العَصْرِ البرُونْزِيِّ وَالعَصْرِ الحَدِيْدِيِّ
21-40 Bronze Age and Iron Age; epochs: Hallstatt period, La Tène period	رَأْسُ رَمْعٍ بَرُونْزِيٍّ خَنْجَرٌ بَرُونْزِيٌّ ذُو مِقْبَضٍ فَاسٌ بَرُونْزِيٌّ ذُو مِقْبَضٍ مُنْتَبِتٌ إِلَى حَلَقَاتٍ
21 bronze spear head	دَلَالِيَةٌ مِثَالِيَّةٌ ذَاتُ حِزَامٍ
22 hafted bronze dagger	قِلَادَةٌ، عَقْدٌ
23 socketed axe (Am. ax), a bronze axe with haft fastened to rings	حَلْقَةُ العُنُقِ المِصْرُوعَةٌ مِنَ الذَّهَبِ
24 girdle clasp	مِشْبِكُ أَمَانٍ عَلَى شَكْلِ قَوْسِ الكَمَّانِ
25 necklace (lunula)	مِشْبِكٌ سَرِيْنِيْتِيَّي الشَّكْلِ، نُوْعَانُ أَخْرَاجٍ قَارِيِيٍّ
26 gold neck ring	وَقَوْسٌ دَبُوسٌ ذُو رَأْسٍ مُنْتَبِتِخٍ
27 violin-bow fibula (safety pin)	مِشْبِكٌ حَلْزُونِيٌّ مِنْ قِطْعَتَيْنِ
28 serpentine fibula; other kinds: boat fibula, arc fibula	سَكِيْنٌ بَرُونْزِيٌّ ذُو مِقْبَضٍ مِفْتَاحٌ مِنَ الحَدِيْدِ شَفْرَةٌ مِخْرَاطٍ
29 bulb-head pin, a bronze pin	آبِيَّةٌ ثَامِيَّةٌ مِنَ الوَاحِ البرُونْزِيِّ
30 two-piece spiral fibula; sim.: disc (disk) fibula	إِبْرِيْقٌ خَزْفِيٌّ مَزْخَرَفٌ بِأَلْمُتِ
31 hafted bronze knife	عَرَبِيَّةٌ طَقُوسٌ مُصَغَّرَةٌ
32 iron key	عَمَلَةٌ سَلْتِيَّةٌ مِنَ الفِضَّةِ
33 ploughshare (Am. plowshare)	جَزَةٌ (لِحْفِظِ رَمَادِ المَوْتِيِّ) عَلَى شَكْلِ وَجْهِ أَنْوَاعِهَا
34 sheet-bronze situla, a funerary vessel	جَزَةٌ مِثَالِيَّةٌ وَجَزَةٌ ذَاتُ نَقْشٍ نَائِيٍّ
35 pitcher [chip-carved pottery]	قَبْرٌ عَلَى شَكْلِ جَزَةٍ فِي حِجْرَةٍ حَجْرِيَّةٍ
36 miniature ritual cart (miniature ritual chariot)	جَزَةٌ ذَاتُ عُنُقٍ أَسْطُوَانِيٍّ
37 Celtic silver coin	الفَرُوسِيَّةُ
38 face urn, a cinerary urn; other kinds: embossed urn	قَلْعَةٌ الفَارْسِ (قَلْعَةٌ) الفَنَاءِ الدَاخِلِيِّ
39 urn grave in stone chamber	بُئْرٌ
40 urn with cylindrical neck	بُرْجٌ مَحْصَنٌ
329 Chivalry	تُورَجُ الحِصْنِ الرَّئِيْسِيِّ شُرَفَاتٌ
1 knight's castle (castle)	
2 inner ward (inner bailey)	
3 draw well	
4 keep (donjon)	
5 dungeon	
6 battlements (crenellation)	

درج المذبح
هيكل الجزء المخصص
للقساوسة القائمين بالقداس

31 altar steps
32 presbytery (choir,
chancel, sacarium,
sanctuary)

33 altar
34 altar candles
35 altar cross
36 altar cloth
37 lectern
38 missal (mass book)
39 priest
40 server
41 sedilia

42 tabernacle
43 stela (stela)

44 paschal candle (Easter
candle)
45 paschal candlestick
(Easter candlestick)

46 sanctus bell
47 processional cross
48 altar decoration
(foliage, flower
arrangement)

49 sanctuary lamp
50 altarpiece, a picture of
Christ

51 Madonna (statue of the
Virgin Mary)

52 pricket
53 votive candles
54 station of the Cross

55 offertory box

56 literature stand
57 literature (pamphlets,
tracts)

58 verger (sexton,
sacristan)

59 offertory bag
60 offering
61 man praying
62 prayer book

331 Church II الكنيسة (2)

1 Church الكنيسة
2 steeple بُرج الكنيسة
3 weathercock دوارة الرياح
4 weather vane (wind
vane) دليل اتجاه الرياح
5 spire ball كُرَة قِمَّة البُرْج المُسَدَّدَة
6 church spire (spire) قِمَّة مُسَدَّدَة
7 church clock (tower
clock) ساعة الكنيسة (ساعة البُرْج)
8 belfry window كُرَة بُرْج الجرس
9 electrically operated جرس يُشغَل كهربياً

غطاء البن
سراج المبارزة
غطاء الكفل

86 flanchard (flanchard)
87 tournament saddle
88 rump piece (quarter
piece)

330 Church I

1-30 Protestant church
1 chancel الهيكل
2 lectern المقرء
المقدس
يساط المذبح
المذبح

3 altar carpet
4 altar (communion
table, Lord's table,
holy table)

5 altar steps درج المذبح
6 altar cloth غطاء/مفرش المذبح
7 altar candle شمعان المذبح
8 pyx (pix) حق القربان المقدس
9 paten (patin, patine) طبق القربان المقدس
كأس القربان

III chalice (communion
cup) كأس القربان

11 Bible (Holy Bible,
Scriptures, Holy
Scripture) الكتاب المقدس

12 altar crucifix صليب المذبح (يمثل المسيح
مصلوباً)

13 altarpiece نقش خلف مذبح الكنيسة (أو
قوة)

14 church window نافذة الكنيسة
15 stained glass زجاج ملون
16 wall candelabrum شمعان الجدار
باب مجلس الكنيسة

17 vestry door (sacristy
door) درج الميتر
ميتر الوعظ
غطاء الجزء الامامي من
الميتر

18 pulpit steps درج الميتر
19 pulpit ميتر الوعظ
20 antependium غطاء الجزء الامامي من
الميتر

21 canopy (soundboard,
sounding board) ظلة (فوق شخص ذو منزلة
أو مقدس)
ويعط في دوائه

22 preacher (pastor, vicar,
clergyman, rector) in
his robes (vestments,
canonicals) درابزين الميتر
لوحة التراتيل وهي توضع
أعداد التراتيل
شرفة خارجية
حامل الصولجان (أمام
الأسقف)

23 pulpit balustrade درابزين الميتر
24 hymn board showing
hymn numbers لوحة التراتيل وهي توضع
أعداد التراتيل
شرفة خارجية
حامل الصولجان (أمام
الأسقف)

25 gallery شرفة خارجية
26 verger (sexton,
sacristan) حامل الصولجان (أمام
الأسقف)

27 aisle ممر بين صفي المقاعد
28 pew, collectively: pews مقعد في الكنيسة
(seating) مقعد في الكنيسة

29 churchgoer (worshipper);
collectively: جماعة مصليين
congregation
30 hymn book كتاب التراتيل
31-62 Roman Catholic الكنيسة الكاثوليكية
church الرومانية

الجزء السفلي من سُرَّة
الدرع
قفاز واق
درع واق للمنطقة أسفل
البنط
درع العنق

49 tasse (tasset) الجزء السفلي من سُرَّة
الدرع
قفاز واق
درع واق للمنطقة أسفل
البنط
درع العنق

50 gauntlet
51 habergeon (habergeon)
52 cuisse (cuish, cuissard,
cuissart) غطاء الركبة
غطاء الركبة
درع الرجل
حذاء فولاذي

53 knee cap (knee piece,
genouillère, poyeun) درع الرجل
حذاء فولاذي

54 jambeau (greave) درع الرجل
حذاء فولاذي

55 solleret (sabaton,
sabbaton) درع الرجل
حذاء فولاذي

56 pavis (pavise, pavais) درع الرجل
حذاء فولاذي

57 buckler (round shield) درع الرجل
حذاء فولاذي

58 boss (umbo) درع الرجل
حذاء فولاذي

59 iron hat درع الرجل
حذاء فولاذي

60 morion درع الرجل
حذاء فولاذي

61 light casque درع الرجل
حذاء فولاذي

62 types of mail and
armour (Am. armor) أنواع الزرديات والدروع

63 mail (chain mail, chain
armour, Am. armor) زردية (زردية سلسلية)

64 scale armour (Am.
armor) درع مصفح

65 plate armour (Am.
armor) درع صفحاني

66 accolade (dubbing,
knighting) حفلة الاحتضان حفلة تقام
عند منح شخص رتبة فارس
الموالي

67 liege lord, a knight المرشح لرتبة الفارس
حامل الكأس

68 esquire مُغني القيثارة
مباراة في المصارفة بين
الفرسان
مبارز صليبي
الداوي أحد فرسان الهيكل
غطاء مزركش لسرج الفرس
حكم المبارزة

69 cup bearer درج الميتر
ميتر الوعظ
غطاء الجزء الامامي من
الميتر

70 minstrel (minnesinger,
troubadour) درج الميتر
ميتر الوعظ
غطاء الجزء الامامي من
الميتر

71 tournament (tourney,
joust, just, tilt) مبارزة
الفرسان
مبارز صليبي
الداوي أحد فرسان الهيكل
غطاء مزركش لسرج الفرس
حكم المبارزة

72 crusader مبارز صليبي
الداوي أحد فرسان الهيكل
غطاء مزركش لسرج الفرس
حكم المبارزة

73 Knight Templar مبارز صليبي
الداوي أحد فرسان الهيكل
غطاء مزركش لسرج الفرس
حكم المبارزة

74 caparison (trappings) مبارز صليبي
الداوي أحد فرسان الهيكل
غطاء مزركش لسرج الفرس
حكم المبارزة

75 herald (marshal at
tournament) مبارز صليبي
الداوي أحد فرسان الهيكل
غطاء مزركش لسرج الفرس
حكم المبارزة

76 tilting armour (Am.
armor) درج المصاففة
خوذة المصاففة

77 tilting helmet (jousting
helmet) درج المصاففة
خوذة المصاففة

78 panache (plume of
feathers) يتأش حُرْمَة زينة من
الريش أعلى الخوذة
ترس المصاففة

79 tilting target (tilting
shield) مسند الرمح
رمح المصاففة
درع واق لليد
درع الفرس

80 lance rest مسند الرمح
رمح المصاففة
درع واق لليد
درع الفرس

81 tilting lance (lance) مسند الرمح
رمح المصاففة
درع واق لليد
درع الفرس

82 vamplate مسند الرمح
رمح المصاففة
درع واق لليد
درع الفرس

83-88 horse armour (Am.
armor) مسند الرمح
رمح المصاففة
درع واق لليد
درع الفرس

83 neck guard (neck
piece) مسند الرمح
رمح المصاففة
درع واق لليد
درع الفرس

84 chamfron (chaffron,
chafiron, chamfrain,
chanfron) مسند الرمح
رمح المصاففة
درع واق لليد
درع الفرس

85 poitrel مسند الرمح
رمح المصاففة
درع واق لليد
درع الفرس

7 merlon المارلون الجدار الفاصل
بين شرفات الحصن

8 tower platform منصة البُرْج

9 watchman حارس (خفير)

10 ladies' apartments
(bowers) منزل السيدات

11 dormer window نافذة ناتئة (شباك جملون
(dormer) بارز)

12 balcony بلكون

13 storehouse (magazine) مستودع (مخزن)

14 angle tower بُرْج الزاوية

15 curtain wall (curtains,
enclosure wall) جُدء الجدار بين البُرْجين

16 bastion المنبتين جُرء ناتئ من
الحصن

17 angle tower بُرْج الزاوية

18 crenel (embrasure) كُرَة في جدار الحصن

19 inner wall جدار داخلي

20 battlemented parapet حاجز به شرفات

21 parapet (breastwork) حاجز, مفراس

22 gatehouse البوابة

23 machicolation شرفة مكررة
(machicoulis)

24 portcullis شعريّة التحصين

25 drawbridge جسر متحرك

26 buttress دعامة الجدار

27 offices and service rooms مكاتب وخدمات

28 turret برّيج

29 chapel كنيسة صغيرة

30 great hall القاعة الكبرى

31 outer ward (outer
bailey) الفناء الخارجي

32 castle gate بوابة الحصن

33 moat (ditch) خندق مائي حول الحصن

34 approach طريق الاقتراب

35 watchtower (turret) برج المراقبة

36 palisade (pallisade,
palisading) حسيكة الحصن

37 moat (ditch, fosse) خندق مائي حول الحصن

38-65 knight's armour درع الفارس
(Am. armor)

38 suit of armour (Am.
armor) بدلة الدرع

39-42 helmet الخوذة
الجنيحة

39 skull مقدم الخوذة المتحرك

40 visor (visor) لفاع الخوذة جُرء متحرك
في أسفلها

41 beaver غطاء الرقبة
درع العنق
الكتيفية
صفحة الإبط

42 throat picce غطاء الرقبة

43 gorget درع العنق

44 épaulière الكتيفية

45 pallette (pauldron,
besageur) صفحة الإبط

46 breastplate (cuirass) درع الصدر

47 brassard (rear brace
and vambrace) العضاد درع للذراع أو
عصابة للعضد

48 cubitière (coudière,
couter) حلقة تشير إلى فارس
البلاد

bell	
10 ridge cross	صليب حرف السطح
11 church roof	سطح الكنيسة
12 memorial chapel	كنيسة صغيرة تذكارية
13 vestry (sacristy), an annex (annex)	مجلس الكنيسة، حجرة للاجتماعات والصوف الكنيستية
14 memorial tablet (memorial plate, wall memorial, wall stone)	لوح تذكاري
15 side entrance	مدخل جانبي
16 church door (main door, portal)	باب الكنيسة (الباب الرئيسي)
17 churchgoer	إلف الكنيسة، مُصلي
18 graveyard wall (churchyard wall)	سور المدافن/ المقابر الملحقة بالكنيسة
19 graveyard gate (churchyard gate, lichgate, lychgate)	مدخل المدافن الملحقة بالكنيسة
20 vicarage (parsonage, rectory)	مقر القس
21-41 graveyard (churchyard, God's acre, Am. burying ground)	فناء المقابر/ المدافن
21 mortuary	مستودع الجثث تحفظ فيه لحين دفنها
22 grave digger	حفار القبور
23 grave (tomb)	قبر
24 grave mound	رابية القبر
25 cross	صليب
26 gravestone (headstone, tombstone)	شاهد القبر
27 family grave (family tomb)	مدفن عائلي
28 graveyard chapel	مصلى المقابر
29 child's grave	قبر طفل
30 urn grave	مدفن جزار حفظ رماد الموتى
31 urn	جرة (لحفظ رماد الموتى)
32 soldier's grave	قبر جندي
33-41 funeral (burial)	الجنائز (الدفن)
33 mourners	المتحزون
34 grave	قبر
35 coffin (Am. casket)	كفن
36 spade	جاروف الحفر
37 clergyman	كاهن، رجل الدين
38 the bereaved	أهل الميت
39 widow's veil, a mourning veil	برقع الأرملة
40 pallbearers	حاملو بساط الرحمة
41 bier	نخش، تابوت
42-50 procession (religious procession)	موكب الجنائز
42 processional crucifix	صليب الجنائز يُصنر المسيح مصلوباً
43 cross bearer (crucifer)	حامل الصليب
44 processional banner, a church banner	راية الموكب الجنائزي
45 acolyte	مساعد الكاهن

46 canopy bearer	حامل الظلة
47 priest	القس
48 monstrance with the Blessed Sacrament (consecrated Host)	وعاء القرّبان المقدّس وبه القرّبان المقدّس
49 canopy (baldachin, baldaquin)	ظلة
50 nuns	راهبات
51 participants in the procession	مشاركون في الجنائز
52-58 monastery	الدير
52 cloister	رواق مُعَد مسقوف
53 monastery garden	حديقة الدير
54 monk, a Benedictine monk	راهب، راهب بنديكتي
55 habit (monk's habit)	رداء الراهب
56 cowl (hood)	قلنسوة الراهب
57 tonsure	الحزء الحلق من رأس الراهب
58 breviary	كتاب الصلوات اليومية
59 catacomb, an early Christian underground burial place	سرداب الموتى
60 niche (tomb recess, arcosolium)	مشكاة
61 stone slab	بلاطة حجّرية
332 Church III	الكنيسة (3)
1 Christian baptism (christening)	المعمودية المسيحية
2 baptistery (baptistry)	بيت المعمودية
3 Protestant clergyman	كاهن بروتستانتي
4 robes (vestments, canonicals)	رداء الكاهن
5 bands	شرطان
6 collar	ياقة
7 child to be baptized (christened)	طفل سيتم تعميده
8 christening robe (christening dress)	رداء التعميد
9 christening shawl	شال التعميد
10 font	جرن المعمودية
11 font basin	حوض جرن المعمودية
12 baptismal water	ماء التعميد
13 godparents	العرّبان
14 church wedding (wedding ceremony, marriage ceremony)	إكليل، عقد القران بالكنيسة
15-16 bridal couple	العروسان
15 bride	العروس
16 bridegroom (groom)	العريس
17 ring (wedding ring)	خاتم الزواج
18 bride's bouquet (bridal bouquet)	باقة ورد العروس
19 bridal wreath	تاج العروس
20 veil (bridal veil)	عُرّة العروس
21 [myrtle] buttonhole	عُرّة [إلوضع زهرة الآس]
22 clergyman	الكاهن
23 Witnesses [to the]	شهود [الزيجة]

marriage]	
24 bridesmaid	إشيبة العروس
25 kneeler	مُوطئ الركوع
26 Holy Communion	العشاء الإلهي أو الربّاني
27 communicants	متناولو العشاء الربّاني
28 Host (wafer)	خبز القرّبان المقدّس
29 communion cup	كأس العشاء الربّاني
30 rosary	سبحة
31 paternoster	الصلوة الربانية، الصيغة المكرّرة (رقيّة)
32 Ave Maria; set of 10: decade	السلام المريمي، مجموعة من ١٠ عقد
33 crucifix	صليب يمثل المسيح مصلوباً، المصلوب الأوعية الكنسية
34-54 liturgical vessels (ecclesiastical vessels)	
34 monstrance	وعاء القرّبان المقدّس
35 Host (consecrated Host, Blessed Sacrament)	خبز القرّبان المقدّس
36 lunula (lunule)	علامة هلالية
37 rays	إشعاعات
38 censer (thurible), for offering incense (for incensing)	مبخرة لحرق البخور
39 thurible chain	سلسلة المبخرة
40 thurible cover	غطاء المبخرة
41 thurible bowl	سلطانية المبخرة
42 incense boat	قارب البخور
43 incense spoon	ملعقة البخور
44 cruet set	طاقم أوعية الماء المقدس
45 water cruet	وعاء الماء
46 wine cruet	وعاء الخمر
47 holy water basin	حوض الماء المقدس
48 ciborium containing the sacred wafers	وعاء خبز القرّبان
49 chalice	كأس خمر القرّبان
50 dish for communion wafers	طبق خبز العشاء الربّاني
51 paten (patin, patine)	طبق القرّبان المقدس
52 altar bells	أجراس المذبح
53 pyx (pix)	حق القرّبان المقدس
54 aspergillum	مرشّة الماء المقدس
55-72 forms of Christian crosses	أشكال الصليب المسيحي
55 Latin cross (cross of the Passion)	الصليب اللاتيني (صليب الآلام)
56 Greek cross	الصليب اليوناني
57 Russian cross	الصليب الروسي
58 St. Peter's cross	صليب القديس بطرس
59 St. Anthony's cross (tau cross)	صليب القديس أنطونيوس (الصليب التائي)
60 St. Andrew's cross (saltire cross)	صليب القديس أندروس
61 Y-cross	صليب على شكل حرف Y
62 cross of Lorraine	صليب اللورين
63 ansate cross	صليب الأنسيت
64 patriarchal cross	الصليب البطريركي
65 cardinal's cross	الصليب الكاردينالي

66 papal cross	الصليب البابوي
67 Constantinian cross, a monogram of Christ (CHR)	الصليب القسطنطيني
68 crosslet	صليب صغير
69 cross moline	أطراف صليب روسها ثنائية مُنحنية
70 cross of Jerusalem	صليب أورثليم
71 cross bottonnée (cross treflée)	أطراف صليب ثلاثية الرووس
72 fivefold cross (quintuple cross)	صليب خماسي
73 Celtic cross	الصليب السلتي
333 Art I	الفن (I)
1-18 Egyptian art	الفن المصري
1 pyramid, a royal tomb	هرم، قبر ملكي
2 king's chamber	حجرة الملك
3 queen's chamber	حجرة الملكة
4 air passage	منز الهواء
5 coffin chamber	حجرة التابوت
6 pyramid site	موقع الهرم
7 funerary temple	معبد جنازي
8 valley temple	معبد الوادي
9 pylon, a monumental gateway	بوابة الهيكل الفرعوني
10 obelisks	منسلتان
11 Egyptian sphinx	أبو الهول المصري
12 winged sun disc (sun disk)	قرص الشمس المُجنح
13 lotus column	عمود لوتس الزخارف
14 knob-leaf capital (bud-shaped capital)	تاج عمود على شكل برعم
15 papyrus column	عمود بردي الزخارف
16 bell-shaped capital	تاج عمود جرس الشكل
17 palm column	عمود نخيلي
18 ornamented column	عمود مزين بالخزاف والرسومات
19-20 Babylonian art	الفن البابلي
19 Babylonian frieze	إفريز بابلي
20 glazed relief tile	قرميد بارز ممّوه بالمينا
21-28 art of the Persians	الفن الفارسي
21 tower tomb	قبر برجي
22 stepped pyramid	هرم مدرج
23 double bull column	عمود الثورين
24 projecting leaves	أوراق شجر بارزة
25 palm capital	تاج عمود نخلي
26 volute (scroll)	زخارف حلزونية (لوجة مرسومة رمزية)
27 shaft	جذع العمود
28 double bull capital	تاج عمود الثورين
29-36 art of the Assyrians	الفن الآشوري
29 Sargon's Palace, palace buildings	قصر سرجون، مباني القصر
30 city wall	سور المدينة
31 castle wall	سور الحصن
32 temple tower	برج المعبد، برج مدرج
(ziggurat), a stepped	

(terracod) tower	تُرابَة
33 outside staircase	درج خارجي
34 main portal	البوابة الرئيسية
35 portal relief	التفوق البارزة بالبوابة
36 portal figure	نقش بارز بالبوابة
37 art of Asia Minor	فن آسيا الصغرى
38 rock tomb	مقبرة صخرية
334 Art II	الفن (2)
1-48 Greek art	الفن اليوناني
1-7 the Acropolis	الأكروبول، الإكروبوليس
1 the Parthenon, a Doric temple	بارثنون، معبد دوري
2 peristyle	رواق مُعد
3 pediment	جبهة، تاج البناء
4 crepidoma (stereobate)	قاعدة المبنى
5 statue	تمثال
6 temple wall	سور المعبد
7 propylaea	مدخل المعبد
8 Doric column	عمود دوري
9 Ionic column	عمود أيوني
10 Corinthian column	عمود كورنثي
11-14 cornice	طُف
11 cyma	سبيمة
12 corona	الجزء الثاني من طُف كلاسيكي
13 mutule	زخرفة اغريزية
14 dentils	التثليل
15 triglyph	الطرغlyph
16 metope, a frieze decoration	المتوب
17 regula	نقش أسفل الطرغlyph
18 epistyle (architrave)	أسكفة
19 cyma (cymatium, kymation)	سبيمة
20-25 capital	تاج العمود
20 abacus	وسادة حجرية
21 echinus	صَلب مائل
22 hypotrachelium (gorgerin)	عُق العمود
23 volute (scroll)	زخارف حلزونية (لوحَة مرسومة رمزية)
24 volute cushion	وسادة الزخارف الحلزونية
25 acanthus	أقنعة، الأكانت
26 column shaft	جذع العمود
27 flutes (grooves, channels)	أخاديد، حزوز
28-31 base	قاعدة العمود
28 [upper] torus	قوسرة [علوية]
29 trochilus (concave moulding, Am. moulding)	تجويف
30 [lower] torus	قوسرة [سفلية]
31 plinth	وطيدة، وُرة
32 stylobate	أساس قاعدة العمود
33 stele (stela)	نصب، منسلة صغيرة
34 acroterion (acroterium, acroter)	أكروتير (زينة سفلية)
35 herm (herma, hermes)	تمثال عطارد ذي الغمد

36 caryatid; male: Atlas	كارياتيد، مذكر أطلس
37 Greek vase	مزهريّة يونانية
38-43 Greek ornamentation (Greek decoration, Greek decorative designs)	الزخارف اليونانية
38 bead-and-dart moulding (Am. molding), an ornamental band	شريط زخرفي مرصع باللؤلؤ الزجاجي
39 running dog (Vitruvian scroll)	زخارف حلزونية دارجة
40 leaf ornament	زخارف على شكل ورقة شجر
41 palmette	نُظَلَة
42 egg and dart (egg and tongue, egg and anchor) cyma	سبيمة بيضاوية وهليبية الزخرفة
43 meander	تمعج زخرفي
44 Greek theatre (Am. theater)	المسرح اليوناني
45 scene	مشهد
46 proscenium	خشبة المسرح
47 orchestra	الأوركسترا، الفرقة الموسيقية
48 thymele (altar)	المدبح
49-52 Etruscan art	الفن الإتروسكي
49 Etruscan temple	معبد إتروسكي
50 portico	رواق
51 cella	حجرة التمثال المقدس
52 entablature	المحمول، الطيان
53-60 Roman art	الفن الروماني
53 aqueduct	قناة ماء عالية
54 conduit (water channel)	قناة ماء
55 centrally-planned building (centralized building)	مبنى مركزي
56 portico	رواق
57 reglet	حليّة معمارية مسطحة
58 cupola	قبّة صغيرة
59 triumphal arch	قوس النصر
60 attic	العلوية
61-71 Early Christian art	الفن المسيحي البدئي
61 basilica	بازليك
62 nave	صحن الكنيسة
63 aisle	الجناح جزء جانبي مفصول عن الصحن بصف من الأعمدة
64 apse	محراب، حنيّة
65 campanile	برج جرس الكنيسة
66 atrium	أتريوم (فناء الكنيسة)
67 colonnade	صف الأعمدة
68 fountain	نافورة، فسقية
69 altar	المدبح
70 clerestory (clearstory)	منور الكنيسة
71 triumphal arch	قوس النصر
72-75 Byzantine art	الفن البيزنطي
72-73 dome system	نظام القباب
72 main dome	القبة الرئيسية
73 semidome	نصف قبة

74 pendentive	منثّ القبة، ركن القبة
75 eye, a lighting aperture	كوة لدخول الضوء
335 Art III	الفن (3)
1-21 Romanesque art	الفن الرومي
1-13 Romanesque church, a cathedral	الكنيسة الرومية، كاتدرائية
1 nave	صحن الكنيسة
2 aisle	الجناح: جزء جانبي مفصول عن الصحن بصف من الأعمدة
3 transept	جناح منحل الكنيسة
4 choir (chancel)	جزء الكنيسة المخصص للمؤمنين والكهنة
5 apse	حنية، محراب
6 central tower (Am. center tower)	البرج المركزي
7 pyramidal tower roof	سقف برج هرمي
8 arcading	مُتَطَرَات، سلسلة قناطر
9 frieze of round arcading	طُف من القناطر المستديرة
10 blind arcade (blind arcading)	قناطر مضمّنة
11 lesene, ▯ pilaster strip	طيز، كتف
12 circular window	نافذة/طاقة دائرية
13 side entrance	مدخل جانبي
14-16 Romanesque ornamentation (Romanesque decoration, Romanesque decorative designs)	الزخارف الرومية
14 chequered (Am. checkered) pattern (chequered design)	نموذج الزخارف المربعة
15 imbrication (imbricated design)	نموذج الزخارف المترابطة
16 chevron design	نموذج الحليّات الشارية
17 Romanesque system of vaulting	الطراز الرومي في إقامة العقود
18 transverse arch	قوس مستعرض
19 barrel vault (tunnel vault)	عقد مَهْدِي
20 pillar	رُكْن، عِضَادَة
21 cushion capital	تاج عمود مسطح
22-41 Gothic art	الفن القوطي
22 Gothic church [west-work, west end, west façade], a cathedral	الكنيسة القوطية [الواجهة الغربية]، كاتدرائية
23 rose window	زهريّة، نافذة زهرية
24 church door (main door, portal), a recessed portal	باب الكنيسة (الباب الرئيسي)
25 archivolt	واجهة العقد
26 tympanum	قلب القوسرة
27-35 Gothic structural system	النظام الهيكل للبناء القوطي
27-28 buttresses	دعامات المبنى
27 buttress	دعامة، كتف
28 flying buttress	زافرة نصف قنطرة يدمع

29 pinnacle	بها جدار
30 gargoye	بناء مذنب
31-32 cross vault (groin vault)	مزياب، مزران
31 ribs (cross ribs)	عقد متصالب منكسر
32 boss (pendant)	ضلوع (ضلوع متصالبة)
33 triforium	حليّة مُشدّية
34 clustered pier (compound pier)	عقد ثلاثي الأفواس
35 respond (engaged pillar)	عمود داعم لقوس
36 pediment	الجبهة، تاج البناء
37 finial	قمة البرج المُزخرفة
38 crocket	تخريم نباتي على الخشب، حلية ناتئة منقوشة تشبه ورق النبات
39-41 tracery window, a lancet window	نافذة الزخرفة المتشجيرية، نافذة رُمُحِيّة
39-40 tracery	الزخرفة المتشجيرية
39 quatrefoil	زخرفة رباعية الأوراق
40 cinquefoil	زخرفة خماسية الأوراق
41 mullions	عمد النافذة
42-54 Renaissance art	فن عصر النهضة
42 Renaissance church	كنيسة عصر النهضة
43 projection, a projecting part of the building	نتوء، بروز
44 drum	رقية القبة
45 lantern	منور السقف
46 pilaster (engaged pillar)	طيز، كتف
47 Renaissance palace	قصر عصر النهضة
48 cornice	طُف، كورنيس
49 pedimental window	نافذة الجبهة
50 pedimental window with round gable	نافذة واجهة ذات جبهة مُثلثيّة
51 rustication (rustic work)	طراز ريفي
52 string course	مدماك خطّي
53 sarcophagus	ناووس
54 festoon (garland)	فسطون (إكليل)

336 Art IV	الفن (4)
1-8 Baroque art	الفن الباروكي
1 Baroque church	كنيسة باروكية
2 bull's eye	كوة
3 bulbous cupola	قبّة صغيرة بصليّة الشكل
4 dormer window (dormer)	نافذة ناتئة
5 curved gable	جبهة مُثلثة منحنية على واجهة المبنى
6 twin columns	أعمدة مزدوجة
7 cartouche	إطار مزخرف
8 scrollwork	زخرفة
9-13 Rococo art	فن الروكوكو/الفن الحوضوي
9 Rococo wall	جدار روكوكو
10 coving, a hollow moulding (Am.	ناتئة زخرفية مفرّعة

11 framing	تأطير
12 ornamental moulding (<i>Am.</i> moulding)	ناتئة زخرفية زينية
13 rocaille, a Rococo ornament	زخرفة روكوكية
14 table in Louis Seize style (Louis Seize table)	طاولة طراز لويس سائز
15 neoclassical building (building in neo-classical style), a gateway	مبنى على الطراز الكلاسيكي المحدث
16 Empire table (table in the Empire style)	طاولة على الطراز الإمبراطوري
17 Biedermeier sofa (sofa in the Biedermeier style)	أريكة طراز "بيدمير"
18 Art Nouveau easy chair (easy chair in the Art Nouveau style)	مقعد على طراز الفن المحدث
19-37 types of arch	أنواع القباب/العقود
19 arch	قنطرة، عقد
20 abutment	كتف قنطرة
21 impost	وسادة حجرية، مستقر القوس
22 springer, a voussoir (wedge stone)	حجر خضنر العقد
23 keystone	مفتاح العقد/القوس
24 face	وجه
25 intrados	مُحتنى القوس الداخلي
26 extrados	ظاهر القوس
27 round arch	قوس مستدير، قنطرة مستديرة
28 segmental arch (basket handle)	قوس مؤنور
29 parabolic arch	قوس على شكل قطع مكافئ
30 horseshoe arch	قوس حذوي
31 lancet arch	قوس سهمي
32 trefoil arch	قوس نغلي (ثلاثي فصوص الزخارف)
33 shouldered arch	قوس كتفي
34 convex arch	قوس مُحدب
35 tented arch	قوس ختيمي
36 ogee arch (keel arch)	عقد ذو قوسين متعاكسين "الوجي"
37 Tudor arch	قوس مُفلطح
38-50 types of vault	أنواع العقود (الأسقف المقوسة)
38 barrel vault (tunnel vault)	عقد مهدي
39 crown	تاج البناء
40 side	الجانب
41 cloister vault (cloistered vault)	عقد معقد
42 groin vault (groined vault)	عقد متصالب أو متقاطع
43 rib vault (ribbed vault)	عقد مُصلع
44 stellar vault	عقد نجمي

45 net vault	عقد شبكي
46 fan vault	عقد مروحي
47 trough vault	عقد صندوقي
48 trough	صندوق
49 cavetto vault	عقد ربغ دائري
50 cavetto	حلبة مقعرة

337 Art V

1-6 Chinese art	الفن الصيني
1 pagoda (multi-storey, multistory, pagoda), a temple tower	بأغود (معيد صيني ذو طوابق متعددة)
2 storey (story) roof (roof of storey)	سقف من طابق واحد
3 pailou (paifoo), a memorial archway	قنطرة تذكارية
4 archway	مدخل مقنطر
5 porcelain vase	مزهريّة من البورسلين
6 incised lacquered work	شكل فخاري مطلي بورنيش اللك

7-11 Japanese art

7 temple	معبد
8 bell tower	برج جرسي
9 supporting structure	هيكل الإسناد
10 Bodhisattva (bodhisattva), a Buddhist saint	كاهن بودي
11 torii, a gateway	مدخل ذو حلبة محدبة

12-18 Islamic art	الفن الإسلامي
12 mosque	مسجد، جامع
13 minaret, a prayer tower	مئذنة
14 Mihrab	اتجاه القبلة، محراب الميبر
15 minbar (minibar, pulpit)	ضريح
16 mausoleum, a tomb	عقد مقوّنص
17 stalactite vault (stalactitic vault)	تاج عمود عربي

18 Arabian capital	الفن الهندي
19-28 Indian art	الإله "سيقا" الراقص
19 dancing Siva (Shiva), an Indian god	تمثال بوذا
20 statue of Buddha	أسطبة
21 stupa (Indian pagoda), a mound (dome), a Buddhist shrine	مظلة
22 umbrella	جدار/سور حجري
23 stone wall (<i>Am.</i> stone fence)	بوابة
24 gate	مياني المعبد
25 temple buildings	برج المعبد الهندي
26 shikara (sikar, sikhara, temple tower)	بهو الأسطبة الصغيرة
27 chaitya hall	أسطبة صغيرة
28 chaitya, a small stupa	

29 alabaster	حجر ألبستر
30 alabaster sculpture	نحت ألبستر
31 alabaster vase	قوس حذوي
32 alabaster vase	قوس سهمي
33 alabaster vase	قوس نغلي (ثلاثي فصوص الزخارف)
34 alabaster vase	قوس كتفي
35 alabaster vase	قوس مُحدب
36 alabaster vase	قوس ختيمي
37 alabaster vase	عقد ذو قوسين متعاكسين "الوجي"
38 alabaster vase	قوس مُفلطح
39 alabaster vase	أنواع العقود (الأسقف المقوسة)
40 alabaster vase	عقد مهدي
41 alabaster vase	تاج البناء
42 alabaster vase	الجانب
43 alabaster vase	عقد معقد
44 alabaster vase	عقد متصالب أو متقاطع
45 alabaster vase	عقد مُصلع
46 alabaster vase	عقد نجمي

338 Artist's Studio

1-43 studio	مُرَسَّم، ستوديو الرسام
1 studio skylight	مرسّم، منّحت منور المرَسَم/المنّحت

2 painter, an artist	رَسَّام
3 studio easel	مِسَد المرَسَم
4 chalk sketch, rough draft	رسم أوّلي بالطلاشير
5 crayon (piece of chalk)	قلم طباشير/ملون
6-19 painting materials	مواد التلوين
6 flat brush	فرشاة مسطحة
7 camel hair brush	فرشاة من شعر الجمّل
8 round brush	فرشاة مستديرة
9 priming brush	فرشاة التحضير
10 box of paints (paint-box)	صندوق الألوان
11 tube of oil paint	أنبوب لون زيتي
12 varnish	برنيق، طلاء شفاف
13 thinner	الشر مادة الترقيق
14 palette knife	سكين الملوّنة/الموْشاة
15 spatula	المُلوّق أداة مزج الألوان
16 charcoal pencil (charcoal, piece of charcoal)	قلم فحم
17 tempera (gouache)	أنبوب ألوان غواش
18 watercolour (<i>Am.</i> watercolor)	ألوان مائية
19 pastel crayon	قلم ألوان بسّتل
20 wedged stretcher (canvas stretcher)	إطار شد قماش اللوحة
21 canvas	قماش اللوحة، الخيش
22 piece of hardboard, with painting surface	قطعة من لوح صلد وعليها سطح التلوين
23 wooden board	لوح خشبي
24 fibreboard (<i>Am.</i> fiber-board)	رقاقة ليفية
25 painting table	طاولة الألوان
26 folding easel	ميسد قابل للطي
27 still life group, a motif	مجموعة طبيعية صامتة، عنصر

28 palette	ملوّنة، موْشاة
29 palette dipper	مغرقة الملوّنة
30 platform	منصّة، تخت
31 lay figure (mannequin, manikin)	شاخص، مانيكان
32 nude model (model, nude)	موديل عارٍ
33 drapery	تغطاء فضاء
34 drawing easel	مِسَد الرَسَم (بدون ألوان)
35 sketch pad	لوحة الرَسَم الأوّلي
36 study in oils	رسم إبداعي من ألوان الزيت
37 mosaic (tessellation)	الفسيفساء
38 mosaic figure	صورة من الفسيفساء
39 tesserae	فصوص الفسيفساء
40 fresco (mural)	فريسك
41 sgraffito	اسجرافيت
42 plaster	جبس، كلس
43 cartoon	كرتون

339 Sculptor's Studio

1 sculptor	مُنّحت، ستوديو النحات
2 proportional dividers	نحات، مقسّم النَسَب/الأبعاد

3 calliper (caliper)	مِسَمَك
4 plaster model, a plaster cast	نموذج/موديل من الجص
5 block of stone (stone block)	كتلة من الحجر
6 modeller (<i>Am.</i> modeler)	النمّال، ناسخ التماثيل
7 clay figure, a torso	شكل من الصلصال، جذع تمثال
8 roll of clay, a modelling (<i>Am.</i> modeling) substance	لغيفة من الصلصال، مادة قولبة
9 modelling (<i>Am.</i> modeling) stand	حامل القولبة
10 wooden modelling (<i>Am.</i> modeling) tool	أداة قولبة خشبية
11 wire modelling (<i>Am.</i> modeling) tool	أداة قولبة سلكية
12 beating wood	عصا الدق
13 claw chisel (toothed chisel, tooth chisel)	منّحت مسنّن
14 flat chisel	منّحت مسطح
15 point (punch)	سُنّك
16 iron-headed hammer	مطرقة برأس حديدية
17 gouge (hollow chisel)	مفلّط، منّحت مجوّف
18 spoon chisel	منّحت ملعقي
19 wood chisel, a bevelled-edge chisel	منّحت خشبي
20 V-shaped gouge	مفلّط على شكل حرف V
21 mallet	مطرقة النحات
22 framework	إطار، هيكل خشبي
23 baseboard	لوح القاعدة
24 armature support (metal rod)	مِسَد الهيكل المعدني
25 armature	هيكل معدني (تسليح التماثيل)
26 wax model	نموذج/موديل شمعي
27 block of wood	كتلة من الخشب
28 wood carver (wood sculptor)	نحات الخشب
29 sack of gypsum powder (gypsum)	شوال من الجص الناعم
30 clay box	صندوق الصلصال
31 modelling (<i>Am.</i> modeling) clay	صلصال القولبة
32 statue, a sculpture	تمثال، شكل منحوت
33 low relief (bas-relief)	نحت نايف
34 modelling (<i>Am.</i> modeling) board	لوح القولبة
35 wire frame, wire netting	إطار سلكي
36 circular medallion (tondo)	رصيبة مستديرة
37 mask	قناع
38 plaque	لوحة منقوشة، أليكيه

340 Graphic Art

1-13 wood engraving (xylography), a relief printing method (a	فَنُ الجرافيك النّقش على الخشب، إحدى طرق النّقش التائر
---	--

letterpress printing method) 1 end-grain block for wood engravings, a wooden block 2 wooden plank for woodcutting, a relief image carrier 3 positive cut 4 plank cut 5 burin (graver) 6 U-shaped gouge 7 scoper (scauper, scalper) 8 scoop 9 V-shaped gouge 10 contour knife 11 brush 12 roller (brayer) 13 pad (wiper) 14-24 copperplate engraving (chalcography), an intaglio process; kinds: etching, mezzotint, aquatint, crayon engraving 14 hammer 15 burin 16 etching needle (engraver) 17 scraper and burnisher 18 roulette 19 rocking tool (rocker) 20 round-headed graver, a graver (burin) 21 oilstone 22 dabber (inking ball, ink ball) 23 leather roller 24 sieve 25, 26 lithography (stone lithography), a planographic printing method 25 sponge for moistening the lithographic stone 26 lithographic crayons (greasy chalk) 27-64 graphic art studio, a printing office (*Am.* printery) 27 broadside (broadsheet, single sheet) 28 full-colour (*Am.* full-color) print (colour print, chromolithograph) 29 platen press, a hand press

كحلة خشبية للحفر 1 لوح خشبي ثخين للنقش على الخشب، حامل صورة ناتئة 2 نقش النسخة الإيجابية 3 نقش اللوح الخشبي 4 منقّاش، محفّار 5 منقّاش على شكل حرف U 6 منقّاش، منحات 7 منقّاش 8 منقّاش على شكل حرف V 9 سكين النطاق 10 فرشاة 11 مطبّع التّصريس 12 ناتئة زخرفية زينية 13 المنقش على الحساس، أنواعه بالحفر، تطليبي، ملون بالقلم 14 مطرقة 15 منقّاش، محفّار 16 إبرة الحفر 17 منقّاش ومضغّال الدحرجة 18 محفّار للنقش على الصخر 19 منقّاش ذو رأس مستديرة 20 المسنّ الزيتي حجر السن بالزيت 21 كربة التحبير 22 مطبّع جلدّي 23 منقش 24 الطباعة الحجرية، إحدى طرق الطباعة على الأسطح المستوية 25 إسفنجة لترطيب حجر الطباعة الحجرية 26 أقلام الطباعة الحجرية (طباشير شحمي) 27-64 مرسوم الفنّون الترسيمية، ستوديو فنّ الجرافيك 28 لوحة عرضية 29 طباعة ملوّنة بالكامل 30 toggle 31 platen 32 type forme (*Am.* form) 33 feed mechanism 34 bar (devil's tail) 35 pressman 36 copperplate press 37 tympan 38 pressure regulator 39 star wheel 40 cylinder 41 bed 42 felt cloth 43 proof (pull) 44 copperplate engraver 45 lithographer (litho artist), grinding the stone 46 grinding disc (disk) 47 grain (granular texture) 48 pulverized glass 49 rubber solution 50 tongs 51 etching bath for etching 52 zinc plate 53 polished copperplate 54 cross hatch 55 etching ground 56 non-printing area 57 lithographic stone 58 register marks 59 printing surface (printing image carrier) 60 lithographic press 61 lever 62 scraper adjustment 63 scraper 64 bed 341 Script I 1-20 scripts of various peoples 1 ancient Egyptian hieroglyphics, a pictorial system of writing 2 Arabic 3 Armenian 4 Georgian 5 Chinese 6 Japanese 7 Hebrew (Hebraic) 8 cuneiform script 9 Devanagari script employed in Sanskrit 10 Siamese

آلية الفعل المفصليّ 30 كيسة مسطحة 31 فورمة الحروف المطبعية 32 آلية التغذية 33 ذراع الماكينة 34 عامل ماكينة الطبوع 35 ماكينة طباعة ذات رؤس نحاسي 36 التيمان 37 منظم الضغط 38 عجلة نجمية 39 طنبور، أسطوانة 40 فرشاة 41 لبادنة 42 بروفة الطباعة 43 عامل طباعة بالرّوسم 44 نحاسي 45 عامل طباعة ليثوغرافية 46 قرص المصقل/التجليح 47 حبيبات 48 زجاج مسحوق 49 سائل مطاطي 50 كلابية 51 حوض الحفر 52 لوح زنك 53 لوح نحاسي مصقول 54 حزون مقطاعة 55 أرضية الحفر 56 منطقة اللاباطعة 57 حجر الطباعة الليثوغرافية 58 علامات تطابق (علامات تسجيل) 59 سطح الطبوع 60 ماكينة طبع ليثوغرافي 61 ذراع الماكينة 62 مضغيب المكشط 63 مكشطة 64 فرشاة أشكال الكتابة (1) أشكال كتابيات شعوب مختلفة الكتابة المصرية القديمة الهيروغليفية، نظام كتابة بالرّسوم الكتابة العربية الكتابة الأرمنية الكتابة الجورجية الكتابة الصينية الكتابة اليابانية الكتابة العبرية الكتابة المسمارية الكتابة السنسكريتية الكتابة السيامية 11 Tamil 12 Tibetan 13 Sinaitic script 14 Phoenician 15 Greek 16 Roman capitals 17 uncial (uncials, uncial script) 18 Carolingian (Carlovingian, Caroleine) minuscule 19 runes 20 Cyrillic 21-26 ancient writing implements 21 Indian steel stylus for writing on palm leaves 22 ancient Egyptian reed pen 23 writing cane 24 brush 25 Roman metal pen (stylus) 26 quill (quill pen) 27 Korean 342 Script II 1-15 types (type faces) 1 Gothic type (German black-letter type) 2 Schwabacher type (German black-letter type) 3 Fraktur (German black-letter type) 4 Humanist (Mcdaeval) 5 Transitional 6 Didone 7 Sanserif (Sanserif type, Grotisque) 8 Egyptian 9 typescript (typewriting) 10 English hand (English handwriting, English writing) 11 German hand (German handwriting, German writing) 12 Latin script 13 shorthand (shorthand writing, stenography) 14 phonetics (phonetic transcription) 15 Braille 16-29 punctuation marks (stops) 16 full stop (period, full point)

الكتابة التاميلية الكتابة التبتية الكتابة السينيتكية الكتابة الفينيقية الكتابة اليونانية الحروف الرومانية الاستهلالية/التاجية الحروف الإنشائية النقطتان الفاصلة الفاصلة المتقوّطة علامة الاستفهام علامة التأثر/التعجب الفاصلة العليا الشّرطة القوسان المعقّقان علامة الاقتباس علامة الاقتباس الفرنسية الواصلة علامات الحذف العلامات النقطيّة والصوتيّة نبذة حادة نبذة خفيفة نبذة فوق حروف العلة تشير إلى طريقة نطقها السدلية [تحت حرف c] علامة توضع على الحرف الثاني من حروف العلة إشارة إلى أن لفظ مكشع مستقل [فوق حرف c] الكدة علامة توضع فوق حرف في الإسبانية علامة فصل الجريدة، الصحيفة، جريدة قومية يومية 37 newspaper page 38 front page 39 newspaper heading 40 contents 41 price 42 date of publication 43 place of publication 44 headline 45 column 46 column heading 47 column rule 48 leading article (leader, editorial) 49 reference to related article 50 brief news item 51 political section 52 page heading 53 cartoon

mathematics	مُتَوَالِيَةٌ حسابية من العوامل
11 arithmetical series with the elements 2, 4, 6, 8	2, 4, 6, 8
12 geometrical series	مُتَوَالِيَةٌ هندسية
13-14 infinitesimal calculus	التفاضل والتكامل اللانهائي
13 derivative [dx, dy: the differentials; d: differential sign]	المشتق dx, dy أرقام تفاضلية: d علامة التفاضل
14 integral (integration) [x: the variable; C: constant of integration; ∫: the integral sign; dx: the differential]	تكامل (x المتغير: C ثابت التكامل; ∫: علامة التكامل; dx رقم التفاضل)
15-24 mathematical symbols	الرموز الحسابية
15 infinity	لانهايتي
16 identically equal to (the sign of identity)	مطابق لـ
17 approximately equal to	مساو تقريبا لـ
18 unequal to	لا يساوي
19 greater than	أكبر من
20 less than	أقل من
21-24 geometrical symbols	الرموز الهندسية
21 parallel (sign of parallelism)	بوازي (علامة التوازي)
22 similar to (sign of similarity)	يمائل (علامة التماثل)
23 angle symbol	رَمَزُ الزَاوِيَةِ
24 triangle symbol	رَمَزُ المثلث
346 Mathematics III (Geometry I)	الرِياضيَّاتُ (3) (المهندسة 1) الهندسة المستوية
1-58 plane geometry (elementary geometry, Euclidian geometry)	
1-23 point, line, angle	نُقْطَةٌ ، حَظٌّ ، زاوية
1 point [point of intersection of g ₁ and g ₂ , the angular point of g ₂]	نُقْطَةٌ [نُقْطَةٌ تقاطع g مع g ₂]
2, 3 straight line g ₂	المستقيم g ₂
4 the parallel to g ₂	المستقيم الموازي للمستقيم g ₂
5 distance between the straight lines g ₂ and g ₃	المسافة بين المُستقيمين g ₂ وg ₃
6 perpendicular (g ₄) on g ₂	العمود g ₄ المتعامد على g ₂
7, 3 the arms of 8	ضلعوا الزاوية 8
8, 13 vertically opposite angles	زاويتان متقابلتان
8 angle	زاوية
9 right angle [90°]	زاوية قائمة (90 درجة)
10, 11, 12 reflex angle	زاوية منعكسة
10 acute angle, also the alternate angle to 8	زاوية حادة، أيضا زاوية متبادلة مع زاوية 8
11 obtuse angle	زاوية منفرجة
12 corresponding angle to 10	زاوية مطابقة لزاوية 10
13, 9, 15 straight angle	زاوية مُستقيمة [180]

المضروب (3). المضروب ×	في علامة الضرب، 2 المضروب فيه، 3 و 6 عاملوا الضرب، 6 ناتج الضرب
القسمة (6 المقسوم ÷ على علامة القسمة)	2 المقسوم عليه، 3 خارج القسمة
الرياضيات (2) الحساب العمليات الحسابية المتقدمة	
الرفع إلى قوة [3 تربع (3 ²) القوة، 3 الأساس، 2 الأس: قيمة القوة]	مَرَجُ الجذور [الجذر التكعيبي لعدد 8 جذر تكعيبي، 8 الأساس، 3 درجة الجذر، √ علامة جذرية، 2 قيمة الجذر]
جذر مربع الجبر	مُعَادَلَةٌ بسيطة (3، 2) معاملمان x كمية غير معروفة
معاداة بسيطة (3، 2) x: unknown quantity	معاداة متطابقة (أ، ب، ج)
معاداة بسيطة (3، 2) x: unknown quantity	رموز جبرية حساب اللوغاريتم (لو رمز اللوغاريتم: 3 العدد المطلوب حساب اللوغاريتم له: 10 الأساس، 4771 العدد البياني، الجزء العشري من اللوغاريتم: 0.4771 اللوغاريتم]
معاداة بسيطة (3، 2) x: unknown quantity	صيغة مبسطة لحساب الفائدة [P: المبلغ الأساسي: R نسبة الفائدة: T الزمن: I الفائدة: % علامة النسبة المئوية]
معاداة بسيطة (3، 2) x: unknown quantity	قاعدة الثلاثة (التناسب البسيط)
بيان بكمية غير معروفة x	معاداة (معاداة شرطية)
الحل	الرياضيات الأعلى

25 multiplication (multiplying); [3: the multiplicand; x: multiplication sign; 2: the multiplier; 2 and 3: factors; 6: the product]	عدد مادي (قيمة مادية) تتكون من القيمة الرقمية ورمز الوحدة/الوحدات
26 division (dividing); [6: the dividend; ÷: division sign; 2: the divisor; 3: the quotient]	عدد ترتيبي
345 Mathematics II	
1-24 arithmetic	
1-10 advanced arithmetical operations	
1 raising to a power [three squared (3 ²): the power; 3: the base; 2: the exponent (index); 9: value of the power]	عدد موجب [+]
2 evolution (extracting a root); [cube root of 8: cube root; 8: the radical; 3: the index (degree) of the root; √: radical sign; 2: value of the root]	عدد سالب [-]
3 square root	رموز جبرية
4-5 algebra	عدد كسري [3 عدد صحيح، 1/3 كسُر]
4 simple equation [3, 2: the coefficients; x: the unknown quantity]	أعداد زوجية
5 identical equation; [a, b, c: algebraic symbols]	أعداد فردية
6 logarithmic calculation (taking the logarithm, log); [log: logarithm sign; 3: number whose logarithm is required; 10: the base; 0: the characteristic; 4771: the mantissa; 0.4771: the logarithm]	أعداد أولية
7 simple interest formula [P: the principal; R: rate of interest; T: time; I: interest (profit); %: percentage sign]	عدد مُركَّب [3 عدد حقيقي، 2√-1 عدد تخيلي]
8-10 rule of three (rule-of-three sum, simple proportion)	الكسور الاعتيادية
8 statement with the unknown quantity x	كسُر غير حقيقي
9 equation (conditional equation)	كسُر مُركَّب
10 solution	كسُر غير حقيقي عند الاختزال ينتج عدد صحيح
11-14 higher	كسور مختلفة المقام [35 مقام مشترك]
	كسُر عَشْرِي حقيقي بفاصلة عشرية [3 عشرات، 5 مئات، 7 آلاف]
	كسُر عَشْرِي دائري
	العمليات الحسابية الأساسية
	الجمع [3 و 2 رقمًا الجمع + زائد (علامة الجمع) = تساوي، 5 حاصل الجمع]
	الطرح [3 المطروح منه - ناقص (علامة الطرح) = المطروح، 1 الباقي]

54 report by newspaper's own correspondent	تقرير من مراسل الجريدة
55 news agency's sign	رَمَزُ وكالة الأنباء
56 advertisement (coll. ad)	إعلان
57 sports section	قسم أخبار الرياضة
58 press photo	صورة صحفية
59 caption	تعليق الصورة
60 sports report	تقرير الأنشطة الرياضية
61 sports news item	خبر رياضي
62 home and overseas news section	قسم الأخبار المحلية والخارجية
63 news in brief (miscellaneous news)	أخبار قصيرة
64 television programmes (Am. programs)	برامج التلفزيون
65 weather report	تقرير حالة الطقس
66 weather chart (weather map)	خريطة الطقس
67 arts section (feuilleton)	قسم الأخبار الفنية
68 death notice	إشعار وفاة
69 advertisements (classified advertising)	إعلانات مدفوعة
70 job advertisement, a vacancy (a situation offered)	إعلان وظائف شاغرة
343 Colour (Am. Color)	الألوان
1 red	أحمر
2 yellow	أصفر
3 blue	أزرق
4 pink	قرمزي
5 brown	بني
6 azure (sky blue)	سماوي
7 orange	برتقالي
8 green	أخضر
9 violet	بنفسجي
10 additive mixture of colours (Am. colors)	مزيج جمعي من الألوان
11 white	أبيض
12 subtractive mixture of colours (Am. colors)	مزيج طرحي من الألوان
13 black	أسود
14 solar spectrum (colours, Am. colors, of the rainbow)	الطيف الشمسي (ألوان قوس قزح)
15 grey (Am. gray) scale	مدرج اللون الرمادي
16 heat colours (Am. colors)	الألوان الساخنة
344 Mathematics I	
1-26 arithmetic	الرِياضيَّاتُ (1) الحساب
1-22 numbers	الأعداد
1 Roman numerals	الأعداد الرومانية
2 Arabic numerals	الأعداد العربية
3 abstract number, a four-figure number [8: units; 5: tens; 6: hundreds; 9: thousands]	عدد معنوي: عدد رباعي [8 أحاد، 5 عشرات، 6 مئات، 9 آلاف]

[180°] درجة
14 adjacent angle; here: supplementary angle to 13 زاوية مجاورة هنا: الزاوية المكملّة للزاوية 13
15 complementary angle to 8 زاوية متممة لزاوية 8
16 straight line AB المستقيم AB
17 end A الطرف A
18 end B الطرف B
19 pencil of rays حزمة أشعة
20 ray شعاع
21 curved line خط منحنى
22 radius of curvature نصف قطر التقوس / الانحناء
23 centre (Am. center) of curvature مركز التقوس / الانحناء
24-58 plane surfaces أسطح مسوية
24 symmetrical figure شكل تناظري
25 axis of symmetry محور التناظر
26-32 plane triangles مثلثات مسوية
26 equilateral triangle [A, B, C: the vertices; a, b, c: the sides; α (alpha), β (beta), γ (gamma): the interior angles; α', β', γ': the exterior angles; S: the centre (Am. center)] مثلث متساوي الأضلاع [A, B, C: رؤوس المثلث; a, b, c: الأضلاع; α (ألفا), β (بيتا), γ (جاما): زوايا داخلية; α', β', γ': الزوايا الخارجية; S: المركز (Am. center)]
27 isosceles triangle [a, b: the sides (legs); c: the base; h: the perpendicular, an altitude] مثلث متساوي الساقين [a, b: ضلعان; c: القاعدة; h: عمود]
28 acute-angled triangle with perpendicular bisectors of the sides مثلث حاد الزاوية ذو أعمدة تصفية للضلع
29 circumcircle (circumscribed circle) دائرة محيطية
30 obtuse-angled triangle with bisectors of the angles مثلث منفرج الزاوية ذو منصفات للزوايا
31 inscribed circle دائرة داخلية
32 right-angled triangle and the trigonometrical functions of angles [a, b: the catheti; c: the hypotenuse; γ: the right angle; %c = sin α (sine); %c = cos α (cosine); %b = tan α (tangent); %a = cot α (cotangent)] مثلث قائم الزاوية ودالات حساب المثلثات الخاصة بالزوايا: a, b ضلعا الزاوية القائمة; c: الوتر; γ الزاوية القائمة; %c = sin α (جيب الزاوية القائمة); %c = cos α (جيب التمام); %b = tan α (ظل الزاوية); %a = cot α (ظل التمام)
33-39 quadrilaterals الأشكال الرباعية
33-36 parallelograms المتوازيات
33 square [d: a diagonal] مربع [d: خط قطري]
34 rectangle مستطيل
35 rhombus (rhomb, lozenge) معين
36 rhomboid متوازي أضلاع
37 trapezium معين منحرف
38 deltoid (kite) متحرف الأضلاع

39 irregular quadrilateral شكل رباعي غير منتظم
40 polygon مضلع
41 regular polygon مضلع منتظم
42 circle دائرة
43 centre (Am. center) مركز الدائرة
44 circumference (periphery) محيط الدائرة
45 diameter قطر الدائرة
46 semicircle نصف دائرة
47 radius (r) نصف قطر
48 tangent مماس
49 point of contact (P) نقطة التماس
50 secant قاطع
51 the chord AB وتر AB
52 segment قطعة
53 arc قوس
54 sector قطاع
55 angle subtended by the arc at the centre (Am. center) (centre, Am. center, angle) الزاوية المركزية المقابلة للقوس
56 circumferential angle زاوية محيطية
57 ring (annulus) حلقة
58 concentric circles دائرتان متحدتا المركز
347 Mathematics IV (Geometry II) الرياضيات (4) (الهندسة 2)
1 system of right-angled coordinates نظام الإحداثيات قائمة الزوايا
2-3 axes of coordinates (coordinate axes) محاور الإحداثيات
2 axis of abscissae (x-axis) محور الإحداثيات السيني (الأفقي)
3 axis of ordinates (y-axis) محور الإحداثيات الصادي (الرأسي)
4 origin of ordinates منشأ الإحداثيات
5 quadrant [I-IV: 1st to 4th quadrant] قطاع ربعي [I-IV: من الربع الأول إلى الرابع]
6 positive direction اتجاه موجب
7 negative direction اتجاه سالب
8 points [P1 and P2] in the system of co-ordinates; x1 and y1 [and x2 and y2 respectively] their coordinates النقطتان [P1 و P2] في النظام الإحداثي; إحداثيات النقطتين x1 و y1 و x2 و y2 على التوالي
9 values of the abscissae [x1 and x2] (the abscissae) قيمتا الإحداثي السيني [x1 و x2]
10 values of the ordinates [y1 and y2] (the ordinates) قيمتا الإحداثي الصادي [y1 و y2]
11-29 conic sections المقطعات المخروطية
11 curves in the system of coordinates الانحناءات في نظام الإحداثيات
12 plane curves [a: the gradient (slope) of the curve; b: the ordinates' intersection of the curve; c: the root of the منحنيات مسوية [a: ميل المنحنى; b: تقاطع الإحداثي الصادي مع المنحنى; c: جذر المنحنى]

curve]
13 inflected curves منحنيات منقلبة
14 parabola, a curve of the second degree قطع مكافئ، منحنى من الدرجة الثانية
15 branches of the parabola فروعاً القطع المكافئ
16 vertex of the parabola رأس القطع المكافئ
17 axis of the parabola محور القطع المكافئ
18 a curve of the third degree منحنى من الدرجة الثالثة
19 maximum of the curve أعلى نقطة في المنحنى
20 minimum of the curve أدنى نقطة في المنحنى
21 point of inflexion (of inflection) نقطة الانقلاب
22 ellipse قطع ناقص
23 transverse axis (major axis) محور متزاوج
24 conjugate axis (minor axis) محور متزاوج
25 foci of the ellipse [F1 and F2] بورتا القطع الناقص [F2 و F1]
26 hyperbola القطع الزائد
27 foci [F1 and F2] بورتان [F2 و F1]
28 vertices [S1 and S2] رأسا القطع المكافئ [S2 و S1]
29 asymptotes [a and b] خطان مقاربان [b و a]
30-46 solids المجسّمات
30 cube مكعب
31 square, a plane (plane surface) مربع، سطح مستو
32 edge حافة
33 corner زاوية، ركن
34 quadratic prism منشور رباعي
35 base قاعدة
36 parallelepiped متوازي السطوح
37 triangular prism منشور ثلاثي الزوايا
38 cylinder, a right cylinder أسطوانة، أسطوانة قائمة
39 base, a circular plane قاعدة، سطح مستو دائري
40 curved surface سطح منحنى
41 sphere كرة
42 ellipsoid of revolution مجسم إهليلجي مخروط
43 cone ارتفاع المخروط
44 height of the cone (cone height) مخروط مقطوع
45 truncated cone (frustum of a cone) مخروط مقطوع
46 quadrilateral pyramid هرم رباعي الأسطح
348 Mathematics V (Sets) الرياضيات (5) (المجموعات)
1 the set A, the set {a, b, c, d, e, f, g} المجموعة A، المجموعة {a, b, c, d, e, f, g}
2 elements (members) of the set A عناصر المجموعة A
3 the set B, the set {u, v, w, x, y, z} المجموعة B، المجموعة {u, v, w, x, y, z}
4 intersection of the sets A and B, A ∩ B = {f, g, u} تقاطع المجموعتين A و B، A ∩ B = {f, g, u}

5-6 union of the sets A and B, A ∪ B = {a, b, c, d, e, f, g, u, v, w, x, y, z} اتحاد المجموعتين A و B، A ∪ B = {a, b, c, d, e, f, g, u, v, w, x, y, z}
7 complement of the set B, B' = {a, b, c, d, e} مكمل المجموعة B، B' = {a, b, c, d, e}
8 complement of the set A, A' = {v, w, x, y, z} مكمل المجموعة A، A' = {v, w, x, y, z}
9-11 mappings الإسقاطات
9 mapping of the set M onto the set N إسقاط المجموعة M على المجموعة N
10 mapping of the set M into the set N إسقاط المجموعة M في المجموعة N
11 one-to-one mapping of the set M onto the set N إسقاط المجموعة M على المجموعة N نقطة لنقطة
349 Chemistry Laboratory I معمل الكيمياء (1)
1-38 laboratory apparatus (laboratory equipment) الأجهزة المختبرية
1 Scheidt globe كرة شمات
2 U-tube أنبوب نوئي/على شكل U
3 separating funnel قمع قاصيل
4 octagonal ground-glass stopper سدادة ثمانية من الزجاج المنصفر
5 tap (Am. faucet) حنفية، صنوبر
6 coiled condenser مكثف حلزوني
7 air lock دسام هوائي
8 wash-bottle قنينة غسل
9 mortar هاون
10 pestle مدقة
11 filter funnel (Büchner funnel) قمع ترشيح
12 filter (filter plate) مرشح
13 retort مغووجة
14 water bath حمام مائي
15 tripod حامل ثلاثي
16 water gauge (Am. gage) مقياس مستوى الماء
17 insertion rings حلقات الإيلاج
18 stirrer مزاحك، أداة تقليب
19 manometer for measuring positive and negative pressures مانومتر قياس الضغط الموجب والضغط السالب
20 mirror manometer for measuring small pressures مانومتر ذو مرآة لقياس الضغط المنخفض
21 inlet مدخل
22 tap (Am. faucet) حنفية، صنوبر
23 sliding scale مقياس مدرج منزلق
24 weighing bottle قارورة وزن
25 analytical balance ميزان تحليلي
26 case صندوق
27 sliding front panel لوح أمامي منزلق
28 three-point support حامل ثلاثي النقاط
29 column (balance column) عمود قائم (عمود الميزان)
30 balance beam (beam) عاتق الميزان
31 rider bar قضيب المتقال الركاب

25 orthopinacoid (swallow tail twin crystal) [gypsum]	مُسَطَّحٌ أَمَامِي (أورتونابوكويد) [الجبس]
26 triclinic pinacoids (triclinic crystal system) [copper sulphate, Am. copper sulfate]	مُسَطَّحٌ ثَلَاثِي المَيْل (كبريتات النحاس) [كبريتات النحاس]
27-33 apparatus for measuring crystals (for crystallography)	جهاز قياس البلورات (المقاييس البلورية)
27 contact goniometer	مَقْيَاسُ زوايا التماس
28 reflecting goniometer	مَقْيَاسٌ [غنيومتر] انعكاس
29 crystal	بلورة
30 collimator	كوليماتور (موجّه الأشعة)
31 observation telescope	تلسكوب الرصد
32 divided circle (graduated circle)	دائرة مدرّجة
33 lens for reading the angle of rotation	عدسة قراءة زاوية الدوّارن
352 Ethnology I	علم الأعراق البشرية (I)
1 totem pole	العمود الطوطميّ
2 totem, a carved and painted pictorial or symbolic representation	طوطم شيء منحوت وملون يتخذ رمزا لأسرة أو عشيرة
3 plains Indian	هندي أحمر، هندي السهول الأمريكية
4 mustang, ▯ prairie horse	المنتنغ فرس السهول الأمريكية البري أو نصف البري
5 lasso, ▯ long throwing-rope with running noose	الوَهَق حبلٌ بأخذه أنشوطة لصيد الخيول وما شابهها
6 pipe of peace	غليون هندي غليون طويل
7 wigwam (teepee, teepee)	الوَعْم، التَّيْبِيَّة (خَيْمَةٌ مخروطية من الجلد)
8 tent pole	عمود الخيّمَة
9 smoke flap	مَشْفَعَة خروج الدخان
10 squaw, an Indian woman	هنديّة حُرّاءٌ أمريكيّة
11 Indian chief	زعيم الهنود الحُرّ
12 headdress, an ornamental feather headdress	غطاء الرأس، غطاء رأس زيني من الريش
13 war paint	طلاء الحرب
14 necklace of bear claws	عقد من مخالب الدبّية
15 scalp (cut from enemy's head), a trophy	فِرْوَة رأس (منزوعة من رأس أحد الأعداء)
16 tomahawk, a battle axe (Am. ax)	التَمْهُوك فأس الهنود الحمر
17 leggings	المُطَاق غطاء للساق
18 moccasin, a shoe of leather and bast	المُكْسِين حذاء من الجلد بدون كعب
19 canoe of the forest Indians	الكَنْز قارب صغير يستخدمه الهنود الحمر سكان الغابات
20 Maya temple, a stepped pyramid	معبد المايا، هرم مدرّج

5 plane of symmetry	مستوى التناظر
6 octahedron (eight-faced polyhedron) [gold]	مُجَسِّمٌ ثَمَانِي الأوجُه [ذهب]
7 rhombic dodecahedron [garnet]	المُجَسِّمُ المَعْيَبِيّ ذو الإثني عشر وَجْهًا [عقيق أحمر، غرينيت]
8 pentagonal dodecahedron [pyrite, iron pyrites]	المُجَسِّمُ الخماسي ذو إثني عشر وَجْهًا [بيريت الحديد]
9 pentagon (five-sided polygon)	مضلع مُخَمَّس
10 triakis-octahedron [diamond]	مُجَسِّمٌ ثَلَاثِيّ ثَمَانِي الأوجه [الماس]
11 icosahedron (twenty-faced polyhedron), a regular polyhedron	المُجَسِّمُ المنتظم ذو العشرين وَجْهًا
12 icositetrahedron (twenty-four-faced polyhedron) [leucite]	مُجَسِّمٌ ذو أربعة وعشرين وَجْهًا [الوسيت]
13 hexakis-octahedron (hexoctahedron, forty-eight-faced polyhedron) [diamond]	مُجَسِّمٌ ذو ثمانية وأربعين وَجْهًا [الماس]
14 octahedron with cube [galena]	ثماني الأوجه ذو مكعب [كبريتيد الرصاص الطبيعي] مضلع مُسَدَّس
15 hexagon (six-sided polygon)	مكعب ذو أوجُه ثمانية
16 cube with octahedron [fluorite, fluorspar]	الإضلاع [فلوريت، حجر فلوري]
17 octagon (eight-sided polygon)	سَطْحٌ ثَمَانِي الأضلاع
18-19 tetragonal crystal system	النظام البلّوري الرّباعي
18 tetragonal dipyramid (tetragonal bipyramid)	هرم ثماني رّباعي الأوجُه
19 protoprism with protopyramid [zircon]	مُنشور أولي مع هرم أولي [زركون]
20-22 hexagonal crystal system	النظام البلّوري السداسي
20 protoprism with protopyramid, deutero-pyramid and basal pinacoid [apatite]	مُنشور أولي مع هرم أولي وبنابوكويد سفلي [أباتيت]
21 hexagonal prism	مُنشور سداسي
22 hexagonal (ditrigonal) biprism with rhombohedron [calcite]	مُنشور ثنائي سداسي ذو سطح معيبيّ [كالسيت]
23 orthorhombic pyramid (rhombic crystal system) [sulphur, Am. sulfur]	هرم معيبيّ مستقيم [كبريت]
24-25 monoclinic crystal system	النظام البلّوري أحادي الميل
24 monoclinic prism with clinopinacoid and hemipyramid (hemihedron) [gypsum]	مُنشور أحادي الميل ذو مسطوح مائل وسطح نصف هرمي [الجبس]

قارورة مخروطية الشكل	Erlenmeyer flask (conical flask)
قارورة ترشح	40 filter flask
مرشح مُخَدَّ	41 fluted filter
خفّية تسمح بمرور السائل من اتجاه واحد فقط	42 one-way tap
أنبوب كلوريد الكالسيوم	43 calcium chloride tube
سدانة ذات خفّية	44 stopper with tap
أسطوانة	45 cylinder
جهاز التقطير	46 distillation apparatus (distilling apparatus)
قارورة التقطير	47 distillation flask (distilling flask)
مكثّف	48 condenser
خفّية مرّجة	49 return tap, a two-way tap
قارورة تقطير	50 distillation flask (distilling flask, Claisen flask)
مُجَفّف، وعاء تجفيف	51 desiccator
غطاء ذو أنبوب مُكَمَّم	52 lid with fitted tube
التنقيت	53 tap
خفّية	54 desiccator insert made of porcelain
وليجة المُجَفّف (مصنوعة من البورسلين)	55 three-necked flask
قارورة ثلاثيّة الأعتاق	56 connecting piece (Y-tube)
قطعة توصيل (أنبوب ذات فرّعين)	57 three-necked bottle
قنينة ثلاثيّة الأعتاق	58 gas-washing bottle
قنينة غسل الغاز	59 gas generator (Kipp's apparatus, Am. Kipp generator)
مولّد الغاز (مولّد كيب)	60 overflow container
وعاء الفائض	61 container for the solid
وعاء المواد الصلبة	62 acid container
وعاء الأحماض	63 gas outlet
أنبوب خروج الغاز	

351 Crystals, Crystallography	البلورات وعلم التبلور
1-26 basic crystal forms and crystal combinations [structure of crystals]	الأشكال الأساسية للبلورات وتركيبات البلورات
1-17 regular (cubic, tesseral, isometric) crystal system	النظام البلّوري العادي (مكعب، متساوي الأبعاد، متساوي السّاحور) رباعي الأوجُه [اتراهيدريت]
1 tetrahedron (four-faced polyhedron) [tetrahedrite, fahlerz, fahl ore]	سداسي الأوجُه، بلورة تامة التماثل [ملح صخري]
2 hexahedron (cube, six-faced polyhedron), a holohedron [rock salt]	سداسي الأوجُه، بلورة تامة التماثل [ملح صخري]
3 centre (Am. center) of symmetry (crystal centre)	مركز التناظر (مركز البلور)
4 axis of symmetry (rotation axis)	محور التناظر (محور الدوران)

32 rider holder	حامل المُقَال الرّابك
33 rider	مُقَال رابك للوزن الدقيق
34 pointer	مُؤشّر
35 scale	مقياس مدرّج
36 scale pan	كفّة الميزان
37 stop	حاجز، صند
38 stop knob	مقبض الصند / الحاجز
350 Chemistry Laboratory II	معمل الكيمياء (2)
1-63 laboratory apparatus (laboratory equipment)	الأجهزة المختبرية
1 Bunsen burner	لَبّ بَنْزَن، موقد بَنْزَن
2 gas inlet (gas inlet pipe)	أَشْبُوبَة دخول الغاز
3 air regulator	مُنظّم الهواء
4 Teclu burner	موقد تكلو
5 pipe union	وَصْلَة الأنابيب
6 gas regulator	مُنظّم الغاز
7 stem	جذع
8 air regulator	مُنظّم الهواء
9 bench torch	مصباح مُضدّي
10 casing	غلاف، علبة
11 oxygen inlet	مُدخّل الأكسجين
12 hydrogen inlet	مُدخّل الهيدروجين
13 oxygen jet	منفذ الأكسجين
14 tripod	حامل ثلاثي
15 ring (retort ring)	خفّعة المَعْوَجَات
16 funnel	فَعْم
17 pipe clay triangle	مُثَلث أنبوبيّ من الصلصال
18 wire gauze	شبكة سلكيّة
19 wire gauze with asbestos centre (Am. center)	شبكة سلكيّة مركزها من الأسستوس
20 beaker	كاس، مخبار
21 burette (for measuring the volume of liquids)	سَخَاحَة (مقياس حجم السوائل)
22 burette stand	حامل السَخَاحَات
23 burette clamp	ماسك السَخَاحَة
24 graduated pipette	مأصنة مدرّجة
25 pipette	مأصنة
26 measuring cylinder (measuring glass)	أسطوانة قياس (مخبار قياس)
27 measuring flask	قارورة قياس
28 volumetric flask	قارورة حجميّة
29 evaporating dish (evaporating basin), made of porcelain	جفّة، طبق التبخير (من البورسلين)
30 tube clamp (tube clip, pinchcock)	ماسك أنابيب
31 clay crucible with lid	بوتقة صلصالية ذات غطاء
32 crucible tongs	ملقط البوتقة
33 clamp	ماسك
34 test tube	أنبوب اختبار
35 test tube rack	حامل أنابيب الاختبار
36 flat-bottomed flask	قارورة مسطحة القاعدة
37 ground glass neck	عنق من الزجاج المصقفر
38 long-necked round-bottomed flask	قارورة طويلة العنق مستديرة القاعدة

5	chiton, a linen gown worn as a basic garment	عباءة إغريقيّة (للرجال والنساء)
6	himation, woolen (Am. woolen) cloak	شملة
7	Roman woman	امراة رومانيّة
8	toupee wig (partial wig)	خصلّة من شعر مُستعار تعلق قمة الرأس بظرفيشيل
9	stola	دثار ملوّن
10	palla, a coloured (Am. colored) wrap	رومانيّ
11	Roman	التُّنكَ: رداء روماني طويل
12	tunica (tunic)	الثَّوْبَة: ثوب روماني فضفاض
13	toga	كُتَّار أروماني (رمز للمثريّة الرفيعة)
14	purple border (purple band)	إمبراطورة بيننطيّة
15	Byzantine empress	إكليل مُرَضَع باللؤلؤ
16	pearl diadem	جواهر
17	jewels	عباءة أرومانيّة
18	purple cloak	تلك طويل
19	long tunic	أميرة المانيّة [القرن الثالث عشر]
20	German princess [13th cent.]	تاج (إكليل)
21	crown (diadem)	شريط الدقن
22	chimbus	شُرَّابَة
23	tassel	حبل العباة
24	cloak cord	ثوب نسائي بحزام
25	girt-up gown (girt-up surcoat, girt-up tunic)	عباءة، مغلف فضفاض
26	cloak	الماني يرتدي زيّاً أسبانيّاً، [1575]
27	German dressed in the Spanish style [ca. 1575]	قُبعة بحافة عريضة
28	wide-brimmed cap	عباءة قصيرة (عباءة أسبانيّة، كاب قصير)
29	short cloak (Spanish cloak, short cape)	صدرة ضيقة مُبطنّة
30	padded doublet (stuffed doublet, peasecod)	بنطال قصير محشو
31	stuffed trunk-hose	جندي الماني مُرتَوِّق [1530]
32	lansquenet (German mercenary soldier) [ca. 1530]	صدرة ضيقة مشقوقة بحيث يظهر ما تحتها
33	slashed doublet (paned doublet)	سبروال مُتفتّح
34	Pluderhose (loose breeches, paned trunk-hose, slops)	
35	woman of Basle [ca. 1525]	امراة البازل [1525]
36	overgown (gown)	ثوب خارجي
37	undergown (petticoat)	ثوب تحتاني (تثورة تحتانيّة)
38	woman of Nuremberg [ca. 1500]	امراة نورمبرج [1500]
39	shoulder cape	عباءة للكثفين
40	Burgundian [15th cent.]	برغندي [القرن الخامس عشر]
41	short doublet	صدرة ضيقة صغيرة

21	mummy	مومياء
22	quipa (knotted threads, knotted code of the Incas)	ذات العقدة. أداة مولفة من حبلٍ وعقد صغيرة مختلفة الألوان كان أهل بيرو القدماء يستخدمونها في الحسابات
23	Indio (Indian of Central and South America); here: high-land Indian	هندي أحمر من أمريكا الوسطى والجنوبيّة
24	poncho, a blanket with a head opening used as an armless cloak-like wrap	عباءة البنش
25	Indian of the tropical forest	هندي أحمر من سُكَّان الغابات الاستوائيّة
26	blowpipe	أنبوب نفخ
27	quiver	جعبة
28	dart	سهّم مزيش
29	dart point	سِن السَهْم المزيش
30	shrunken head, a trophy	رأس مفصول منكش
31	bola (bolas), a throwing and entangling device	البولا: سلاح مكوّن من كرتين يرتشق به الحيوان لأسره
32	leather-covered stone or metal ball	حجر أو كرة معدنيّة مغطى بالجلد
33	pile dwelling	مُسكن مصنوع من الخوازيق
34	duk-duk dancer, a member of a duk-duk (men's secret society)	راقص "الداك داك" (جمعية سرية للرجال)
35	outrigger canoe (canoe with outrigger)	كُتُو ذو ذراع امتداديّ
36	outrigger	ذراع امتداديّ
37	Australian aborigine	أرومي أستراليّ أحد سكان أستراليا الأصليين
38	loincloth of human hair	ستار عورة (مُزَر) من شعر آدميّ
39	boomerang, a wooden missile	بومرنج: قذيفة خشبيّة معقوفة
40	throwing stick (spear thrower) with spears	عصا للذقق ذات حجاب
353 Ethnology II		
1	Eskimo	فرد من الإسكيمو
2	sledge dog (sled dog), a husky	كلب جرّ المزلجة
3	dog sledge (dog sled)	مزلجة يجرها الكلاب
4	igloo, a dome-shaped snow hut	كوخ قبابيّ من الجليد
5	block of snow	كتلة من الجليد
6	entrance tunnel	نفق الدخول
7	blubber-oil lamp	مصباح يُضاء بزيت دهن الحوت
8	wooden missile	قذيفة خشبيّة
9	lance	حراب، رمح
10	harpoon	حزبون لصيد الحيتان
11	skin float	طوّف من الجلد
12	kayak, a light one-man	زورق الكياك
canoe		
13	skin-covered wooden or bone frame	إطار خشبيّ أو عظميّ مكوّن بالجلد
14	paddle	مجذاف
15	reindeer harness	لجام حيوان الرنة
16	reindeer	حيوان الرنة
17	Ostyak (Ostiak)	أستيّاك
18	passenger sledge	مزلجة ركاب
19	yurt (yurta), a dwelling tent of the western and central Asiatic nomads	اليورته: خيمة جلديّة أو لماديّة من خيام بدو سيبيريا المتغوليين
20	felt covering	غطاء من اللباد
21	smoke outlet	فتحة تهوية لخروج الدخان
22	Kirghiz	فرد قرغيزيّ من العرق المغولي الذي يقطن سهول آسيا الوسطى
23	sheepskin cap	قبعة من جلد الغنم
24	shaman	الشامان: كاهن يستخدم السحر لمعالجة المرضى ومعرفة المُخبّأ
25	decorative fringe	شراشيب زينة
26	frame drum	طبلة عشاريّة
27	Tibetan	فرد من التبت
28	flintlock with bayonets	المصوّنة، بندقيّة ذات زناد مضمون
29	prayer wheel	عجلة العبادة
30	felt boot	حذاء (بوت) من اللباد
31	houseboat (sampan)	مركب معدّ للسفح، يبيّت في مركب الأذغان
32	junk	اليكك: سفينة شرّاعيّة صينيّة
33	mat sail	شراع
34	rickshaw (ricksha)	جتركتفة عربيّة صغيرة لشخص واحد تستخدم في اليابان
35	rickshaw coolie (cooly)	الكولي: حمال الجتركتفة
36	Chinese lantern	قانونس ورق
37	samurai	ساموراي أحد المحاربين اليابانيين من الطبقة الأرستقراطية
38	padded armour (Am. armor)	درع مُبطّن
39	geisha	فتاة الجيشا
40	kimono	رداء الكيمونو
41	obi	الأوبي: زنار عريض يُشد فوق ثوب يابانيّ
42	fan	مروحة
43	coolie (cooly)	حمال، شيال
44	kris (creese, crease), a Malayan dagger	الكريس: خنجر إندونيسيّ
45	snake charmer	حاوي الأفاعي
46	turban	عمامة
47	flute	فلوت
48	dancing snake	حية راقصة
354 Ethnology III		
علم الأعراف البشريّة (3)		
1	camel caravan	قافلة الإبل
2	riding animal	حيوان الركوب
3	pack animal	حيوان حمل الأمتعة
4	oasis	واحة
5	grove of palm trees	بستان من النخيل
6	bedouin (beduin)	بديوي
7	burnous	برنس
8	Masai warrior	مُحارب من الماساي
9	headdress (hairdress)	غطاء الرأس
10	shield	درع
11	painted ox hide	جلد ثور مطليّ
12	long-bladed spear	رمح طويل النصل
13	negro	زنجي
14	dance drum	طبلة رقص
15	throwing knife	سيكين للرتشق
16	wooden mask	قناع خشبيّ
17	figure of an ancestor	تمثال لأحد الأسلاف
18	slit gong	طبلة قوسيّة الشكل مشقوقة
19	drumstick	عصا الطبلة
20	dugout, a boat hollowed out of a tree trunk	زورق شجريّ
21	negro hut	كوخ الزنوج
22	negress	امراة زنجيّة
23	lip plug (labret)	الثقبية: حلقة تعلق في الشفة بعد تقبها
24	grinding stone	حجر التخليخ
25	Herero woman	امراة من الهيريرو
26	leather cap	كاب من الجلد
27	calabash (gourd)	قوزة
28	beehive-shaped hut	كوخ على شكل خلية النحل
29	bushman	البشمان: أحد سكان الأذغان
30	earplug	خلية أذنيّة
31	loincloth	مُزَر (استار للعودة)
32	bow	قوس
33	knobkerry (knobkerrie), a club with round, knobbed end	ثبوت
34	bushman woman making a fire by twirling a stick	امراة البشمان. وهي تشعل النار بواسطة تدوير عصا
35	windbreak	حاجز الريح
36	Zulu in dance costume	أحد أفراد الزولو يرتدي زي الرقص
37	dancing stick	عصا الرقص
38	bangle	سوار
39	ivory war horn	بوق من العاج. يُنقح فيه لإعلان الحرب
40	string of amulets and bones	خيط من التعاويذ والعظام
41	pigmy	قزم
42	magic pipe for exorcising evil spirits	مُزمار سحريّ لمُرد الأرواح الشريرة
43	fetish	صنم
355 Historical Costumes		
1	Greek woman	امراة إغريقيّة
2	peplos	بيكوس
3	Greek	رجل إغريقيّ
4	petasus (Thessalonian hat)	قبعة البتاسوس

6 mayfly (dayfly, ephemerid)	ذَبَابَةُ نَوَّارٍ ، ابنة يَوْمٍ
7 compound eye	عَيْنٌ مَرَكَّبَةٌ
8 green grasshopper (green locust, meadow grasshopper), an orthopteron (orthopteron insect)	الجَنْدَبُ الأخضرُ
9 larva (grub)	بِرَقَّةٌ ، بَرَقَّةٌ
10 adult insect, an imago	حشرة كاملة النمو
11 leaping hind leg	ساق خلفية للقفز
12 caddis fly (spring fly, water moth), a neuropteran	ذَبَابَةُ الكادس (حشرة شَعْرِيَّة الجَنَاح)
13 aphid (greenfly), a plant louse	إرْقاة المَنَّة حشرة تمتص عصارة النبات
14 wingless aphid	مَنَّةٌ عديمة الأجنحة
15 winged aphid	مَنَّةٌ مَجَنَّحَةٌ
16-20 dipterous insects (dipterans)	الحشرات مزبوجة الجناح
16 gnat (mosquito, midge), a culicid	فَرَس (بَعوضَة صغيرة)
17 proboscis (sucking organ)	خرطوم (عضو المصن)
18 bluebottle (blowfly), a fly	ذَبَابَةُ اللحم الزرقاء
19 maggot (larva)	بِرَقَّة قطعاء
20 chrysalis (pupa)	خادرة
21-23 Hymenoptera	الحشرات غشائية الأجنحة
21-22 ant	النمل
21 winged female	أنثى مَجَنَّحَةٌ
22 worker	شغالة
23 bumblebee (bumblebee)	النحلة العُطَّانَة
24-39 beetles (Coleoptera)	الخنافس
24 stag beetle, a lamelli-corn beetle	خُنْفَساء الخنثَب
25 mandibles	فَكَانٌ
26 trophi	فَتْحَة تغذية
27 antenna (feeler)	قَرْن استشعار (مِصْر)
28 head	رأس
29-30 thorax	الصدر
29 thoracic shield (prothorax)	الدرع الصدري
30 scutellum	حَرْشَفَة ، صفيحة قَرْنِيَّة
31 tergites	ظُهُر حَلَقِيّ
32 stigma	علامة
33 wing (hind wing)	جَنَاح (جَنَاح خلفي)
34 nervure	عِرْق جَنَاح الحشرة
35 point at which the wing folds	النَّوَّة الذي ينطوي عنده الجَنَاح
36 elytron (forewing)	الجناح الغدلي
37 ladybird (Am. lady-bug), a coccinellid	الدَّسُوقَة
38 Ergates faber, a longicorn beetle (longicorn)	القرني خنفساء طويلة القرنان ، خُنْفَس أَقْرَن
39 dung beetle, a lamellicorn beetle	خُنْفَساء الرُّوث

المفصليات

القشريات

1 mitten crab, a crab	سَرَطَان البحر
2 water slater	دُوْبِيَّة البحر
3-39, 48-56 insects	الحشرات
3 water nymph (dragon-fly), a homopteran (homopteron insect)	يَغُسوب ، سُرمان
4 water scorpion (water bug), a rhynchophore	عَقْرَب الماء (بُؤ الماء)
5 raptorial leg	ساق كاسرة/ جارحة

Paramecium (ciliate infusorian)	ميكروسكوبي زَلِق لا يُرى بالعين المجردة
10 cilium	هَدَب
11 macronucleus (megannucleus)	نواة كبيرة
12 micronucleus	نواة ميكروسكوبية
13-39 multicellular animals (metazoans)	الحيوانات مُتَعَدِّة الخلايا
13 bath sponge, a porifer (sponge)	إِسْفنج الصَّام
14 medusa, a disco-medusa, a coelenterate	رَبَّة البحر ، قنديل البحر
15 umbrella	مظلة
16 tentacle	مِص
17 red coral (precious coral), a coral animal (anthozoan, reef-building animal)	مَرْجان أحمر
18 coral colony	مجموعة مَرْجانِيَّة
19 coral polyp	بُولِب مَرْجانِي
20-26 worms (Vermes)	الديدان
20 leech, an annelid	عَلَقَة ، دُوْدَة حَلَقِيَّة
21 sucker	مِصص ، عضو المصن
22 Spirographis, a bristle worm	دُوْدَة الإسيروجرافيس ، دُوْدَة هَلْبِيَّة
23 tube	أَنْبُوب
24 earthworm	الخَرْطُولن دُوْدَة الأرض
25 segment	فَص
26 ciltellum [accessory reproductive organ]	عَضُو التناسل [عضو تناسل إضافي]
27-36 molluscs (Am. mollusks)	الرُخويات
27 edible snail, a snail	حَلَزُون/ قَوْعِص صالح للأكل
28 creeping foot	قَدَم زاحفة
29 shell (snail shell)	صَدَقَة
30 stalked eye	عَيْن ذَنْبِيَّة
31 tentacles (feelers)	قروتن استشعار ، مِصَّسات
32 oyster	مَحَارَة
33 freshwater pearl mussel	مَحَار لُوْلُو المياه العذبة
34 mother-of-pearl (nacre)	أَم اللُّؤلؤ
35 pearl	لُوْلُوَة
36 mussel shell	صَدَقَة المَحَارَة
37 cuttlefish, a cephalopod	الْحَبَّار ، المِصِيد
38-39 echinoderms	العَنَقْدِيَّات
38 starfish (sea star)	نَجْمَة البحر
39 sea urchin (sea hedgehog)	قَفْذ البحر

358 Arthropods

1-2 crustaceans

1 mitten crab, a crab	سَرَطَان البحر
2 water slater	دُوْبِيَّة البحر
3-39, 48-56 insects	الحشرات
3 water nymph (dragon-fly), a homopteran (homopteron insect)	يَغُسوب ، سُرمان
4 water scorpion (water bug), a rhynchophore	عَقْرَب الماء (بُؤ الماء)
5 raptorial leg	ساق كاسرة/ جارحة

77 pigtail wig	شَعْر مُسْتَعَار
78 ribbon (bow)	شَرِيط (بابيون)
79 ladies in court dress [ca. 1780]	سِيَدَات نِيلات المُحَدِّد في لباس البلاط [1780]
80 train	ذَيْل النَّوْب
81 upswept Rococo coiffure	تسريحة شَعْر روكوكو لأعلى
82 hair decoration	زينة للشعر
83 panniered overskirt	تَوْرَة خارجيَّة منفوخة

حديقة الحيوان

356 Zoo (Zoological Gardens)

1 outdoor enclosure	خَطيرة مُنْبِجَة في الهواء الطلق
2 rocks	صخور
3 moat	خَنْدَق مائِي
4 enclosing wall	جِدَار سِجَاجِي
5 animals on show; here: a pride of lions	حيوانات معروضة؛ في الصورة قطع من الأسود زائر حديقة الحيوان
6 visitor to the zoo	زائر حديقة الحيوان
7 notice	لافتة
8 aviary	قفص طيور كبير
9 elephant enclosure	خطيرة الفيلة
10 animal house (e.g. carnivore house, giraffe house, elephant house, monkey house)	بَيْت الحيوانات (مثال بيت آكلات اللحوم ، أو الزراف ، أو الفيلة ، أو القردة)
11 outside cage (summer quarters)	قفص حيوانات خارجي (البَيْت الصيفي للحيوانات)
12 reptile enclosure	بَيْت الزواحف
13 Nile crocodile	تمساح النيل
14 terrarium and aquarium	مَرْبِي الأحياء البرية ومرربي الأحياء المائية
15 glass case	صندوق زجاجي
16 fresh-air inlet	فَتْحَة دخول الهواء الطلق
17 ventilator	فَتْحَة التهوية
18 underfloor heating	جهاز تدفئة سفلي
19 aquarium	مَرْبِي أحياء مائية
20 information plate	لوحة المعلومات
21 flora in artificially maintained climate	نباتات في مناخ صناعي

الفقاريات

الحيوانات وحيدة الخلية

1-12 unicellular (one-celled, single-celled) animals (protozoans)	الأُميَّا
1 amoeba, a rhizopod	نواة الخلية
2 cell nucleus	البروتوبلازم
3 protoplasm	الشَّوَاء الكاذبة
4 pseudopod	حَوَيْصَة إفراسِيَّة
5 excretory vacuole (contractile vacuule, an organelle)	حَوَيْصَة الطعام
6 food vacuole	أَكْتونيفريس حيوان من الشمسيات
7 Actinophrys, a heliozoan	حيوان بحري شعوي؛ في الصورة هيكل سيليكوني
8 radiolarian; here: siliceous skeleton	حَيَوِيَّين (حيوان)
9 slipper animalcule, a	

42 piked shoes (peaked shoes, copped shoes, crackowes, poulaines)	جِذَاء طوِيل مُسَدَّدَق الطرف
43 pattens (clogs)	نَعْل من الخشب
44 young nobleman [ca. 1400]	شَاب نَبِيل [1400]
45 short, padded doublet (short, quilted doublet, jerkin)	مَدْرَة ضيقة قصيرة مُبْنَطَة
46 dagged sleeves (petal-scalloped sleeves)	كَم واسع متدل
47 hose	بَنْطَال ضيق
48 Augsburg patrician lady [ca. 1575]	سَيِّدَة نبيلة من العصر الأوغسطيني [1575]
49 puffed sleeve	كَم مُنتَفخ
50 overgown (gown, open gown, sleeveless gown)	نَوْب خارجي ، عباءة
51 French lady [ca. 1600]	امرأة فرنسية [1600]
52 millstone ruff (cart-wheel ruff, ruff)	طَوِق رَقِيَّة دائري مَشَكَّش
53 corseted waist (wasp waist)	خَصْر نحيل مشدود بيشد
54 gentleman [ca. 1650]	رَجُل نَبِيل المُحَدِّد [1650]
55 wide-brimmed felt hat (cavalier hat)	قُبْعَة لبادية عريضة الحافة
56 falling collar (wide-falling collar) of linen	ياقة ساقطة من الكتان
57 white lining	بطانة بيضاء
58 jack boots (bucket-top boots)	بُوت بواقية للركبة
59 lady [ca. 1650]	سَيِّدَة نبيلة المُحَدِّد [1650]
60 full puffed sleeves (puffed sleeves)	كَم مُنتَفخ بالكامل
61 gentleman [ca. 1700]	رَجُل نَبِيل المُحَدِّد [1700]
62 three-cornered hat	قُبْعَة بثلاثة قرون
63 dress sword	سِيف النَّوْب
64 lady [ca. 1700]	سَيِّدَة نبيلة المُحَدِّد [1700]
65 lace fontange (high headdress of lace)	غطاء رأس بشريط زيمي
66 lace-trimmed loose-hanging gown (loose-fitting housecoat, robe de chambre, negligée, contouche)	عِبَاء فضفاضة مَرَبِيَّة بأشرطة
67 band of embroidery	شَرِيط تطريز
68 lady [ca. 1880]	سَيِّدَة نبيلة المُحَدِّد [1880]
69 bustle	أرْداف مُستعارَة
70 lady [ca. 1858]	سَيِّدَة نبيلة المُحَدِّد [1858]
71 poke bonnet	بُوكَة
72 crinoline	تَوْرَة نافخَة
73 gentleman of the Biedermeier period	رَجُل نَبِيل المُحَدِّد من العصر البيدرميري
74 high collar (choker collar)	ياقة مرتفعة
75 embroidered waistcoat (vest)	مَدْبُورِيَّة مطرزة
76 frock coat	مِخْطَف الفراك/ قصير حتى الركبتين

19 tufted gills	خَيْشُومٌ مُخَصَّلٌ				
20-26 amphibians (amphibians)	الْبِرَامِيَّاتُ				
20-22 salamanders	الْمُضَفِّعِيَّاتُ				
20 greater water newt (crested newt), ■ water newt	سَمْتَدَلُ الْمَاءِ				
21 dorsal crest	قِمَّةٌ ظَهْرِيَّةٌ				
22 fire salamander, a salamander	سَمْتَدَلُ النَّارِ				
23-26 salientians (anurans, batrachians)	الْمَقْفَازَاتُ، الْقَوَافِ				
23 European toad, a toad	ضَفْدَعُ الطَّيْنِ الْأُورُوبِيِّ				
24 tree frog (tree toad)	ضَفْدَعُ الشَّجَرِ				
25 vocal sac (vocal pouch, croaking sac)	كَيْسُ النَّفِيقِ				
26 adhesive disc (disk)	قُرْصٌ لِاصِقٌ				
27-41 reptiles	الرِّبَاحِيَّاتُ				
27, 30-37 lizards	العُظْمَاءُ/السَّحَابِيُّ				
27 sand lizard	عُظَاءَةُ الرَّمَالِ				
28 hawkbill turtle (hawkbill)	سَلْحَفَاءُ بَحْرِيَّةٌ				
29 carapace (shell)	دِرْقَةُ السَّلْحَفَاءِ (دِرْعٌ قَرْنِي)				
30 basilisk	الْبَازِيلِيْقُ (عُظَاءَةٌ أَمْرِيكِيَّةٌ)				
31 desert monitor, a monitor lizard (monitor)	الْوَرَلُ				
32 common iguana, an iguana	الإِغْوَانَةُ عُظَاءَةٌ أَمْرِيكِيَّةٌ				
33 chameleon, one of the Chamaeleontidae (Rhoptoglossa)	إِسْتَوَانِيَّةٌ عَاشِيَةٌ				
34 prehensile foot	الْحَرْبَاءُ				
35 prehensile tail	قَدَمٌ إِمْسَاكِيَّةٌ				
36 wall gecko, a gecko	ذَيْلُ إِمْسَاكِي				
37 slowworm (blindworm), one of the Anguillidae	الْفَرَسُ، أَبُو بَرِيصِ الْعُظَاءَةِ الْعَضِيَاءِ				
38-41 snakes	الْأَفَاعِي				
38 ringed snake (ring snake, water snake, grass snake), a colubrid	أَفْعَى الْمَاءِ				
39 collar	يَاقَةُ				
40-41 vipers (adders)	أَفَاعِي سَامَةٌ				
40 common viper, a poisonous (venomous) snake	أَفْعَى سَامَةٌ شَانِعَةٌ				
41 asp (asp viper)	الصِّلُّ الْمِصْرِيُّ أَفْعَى صَفِيْدَةٌ سَامَةٌ				
365 Lepidoptera (Butterflies and Moths)	قَشْبَرِيَّاتُ الْأَجْنِحَةِ (الْفَرَاشَاتُ وَ الْبَشَارَاتُ)				
1-6 butterflies	الْفَرَاشَاتُ				
1 red admiral	الْأَمِيرَةُ الْحَمْرَاءُ				
2 peacock butterfly	الْفَرَاشَةُ الطَّاوُوسِيَّةُ				
3 orange tip (orange tip butterfly)	الْفَرَاشَةُ الْبَرْتَقَالِيَّةُ				
4 brimstone (brimstone)	كَبْرِيَّةٌ				
5 Camberwell beauty (mourning cloak, mourning cloak butterfly)	فَرَاشَةُ نَهَارِيَّةٌ				
6 blue (lycaenid butterfly, lycaenid)	الْفَرَاشَةُ الزَّرْقَاءُ				
7-11 moths (Heterocera)	الْبَشَارَاتُ فَرَاشَاتٌ لَيْلِيَّةٌ (مُتَحَفِّطَاتُ الْقُرُونِ)				
7 garden tiger	نَمْرُ الصَّدِيقَةِ				
8 red underwing	ذَاتُ الْجَنَاحِ الْخَلْفِيِّ الْحَمْرُ				
9 death's-head hawkmoth, a hawkmoth (sphinx)	فَرَاشَةُ جَمَجَمِيَّةٌ				
10 caterpillar	يَسْرُوعٌ، سُرْفَةٌ				
11 chrysalis (pupa)	خَادِرَةٌ				
366 Mammals I	الْمَذْبِيَّاتُ (1)				
1 platypus (duck-bill, duck-mole), a monotreme (oviparous mammal)	الْبِلَاتْيُوسُ، مَيْقَارُ الْبَيْتَةِ				
2-3 marsupial mammals (marsupials)	الْمَذْبِيَّاتُ الْجَرَابِيَّةُ				
2 New World opossum, ■ didelphid	الْأُوبُوسُومُ حَيَوَانٌ أَمْرِيكِي يُتَظَاهَرُ بِالْمَوْزِ عِنْدَمَا يَحْدِقُ بِهِ خَطَرَ الْكَتْفَرُ الْأَحْمَرُ				
3 red kangaroo (red flyer), a kangaroo	أَكْلَاتُ الْحَشْرَاتِ				
4-7 insectivores (insect-eating mammals)	الْخَدُّ				
4 mole	الْفَقْفَذُ				
5 hedgehog	شَوْكَةٌ				
6 spine	الزِّيَابَةُ				
7 shrew (shrew mouse), one of the Soricidae	الْمَدْرَعُ				
8 nine-banded armadillo (peba)	الْخَفَاشُ طَوِيلُ الْأَذْنَيْنِ				
9 long-eared bat (flutter-mouse), a flying mammal (chiropter, chiropteran)	الْبَنْغُولُ، أُمُ قَرْفَةٌ				
10 pangolin (scaly ante-eater), a scaly mammal	الْكِسْلَانُ ذُو الْإِصْبَعَيْنِ				
11 two-toed sloth (unau)	الْقَوَارِضُ				
12-19 rodents	خَنْزِيرٌ غَنِيَاءُ، الْخَنْزِيرُ الْهِنْدِيُّ				
12 guinea pig (cavy)	الشَّيْهَمُ، النِّيْصُ				
13 porcupine	الْقَنْذَسُ				
14 beaver	الْجُرْبُوعُ				
15 jerboa	الْهَمْسَرُ				
16 hamster	قَارُ الْمَاءِ				
17 water vole	الْمَرْمُوطُ				
18 marmot	السَّجَابُ				
19 squirrel	الْفِيلُ الْأَفْرِيْقِيُّ				
20 African elephant, a proboscidean (proboscidian)					
21 trunk (proboscis)	خَرْطُومٌ				
22 tusk	نَابٌ				
23 manatee (manati, lamantin), a sirenian	خَرْوفُ الْبَحْرِ				
24 South African dassie (das, coney, hyrax), a procaviid	الْأُرْبُوبُ الْأُورُوبِيُّ، الزَّلْمُ				
25-31 ungulates	ذَوَاتُ الْحَوَافِرِ				
25-27 odd-toed ungulates	ذَوَاتُ الْحَوَافِرِ قَرْبِيَّةُ الْأَصَابِعِ				
25 African black rhino, a rhinoceros (nasicorn)	وَجِيدُ الْقَرْنِ، الْكِرْكِرَانُ				
26 Brazilian tapir, a tapir	التَّبِيرُ حَيَوَانٌ أَمْرِيكِي اسْتَوَاشِي شَبِيهِ الْخَنْزِيرِ				
27 zebra	الْحِمَارُ الْوَحْشِيُّ الْمَخْطُطُ				
28-31 even-toed ungulates	ذَوَاتُ الْحَوَافِرِ زَوْجِيَّةُ الْأَصَابِعِ				
28-30 ruminants	الْحَيَوَانَاتُ الْمَجْتَرَةُ				
28 llama	الْلَامَا				
29 Bactrian camel (two-humped camel)	الْجَمَلُ ذُو السَّمَامَيْنِ				
30 guanaco	الْغَوَانَاقُ				
31 hippopotamus	قَرَسُ النَّهْرِ				
367 Mammals II	الْمَذْبِيَّاتُ (2)				
1-10 ungulates, ruminants	ذَوَاتُ الْحَوَافِرِ، مُجْتَرَاتٌ				
1 elk (moose)	الْإِلْكَةُ				
2 wapiti (Am. elk)	الْوَيْبِيتُ الْأَيْلُ الْأَمْرِيكِي				
3 chamois	الشَّمْوَاءُ				
4 giraffe	الزَّرَافَةُ				
5 black buck, an antelope	الظَّبْيُ الْأَسْوَدُ				
6 mouflon (mouflon)	الْمُظْفُونُ				
7 ibex (rock goat, bouquetin, steinbock)	الْوَعْلُ، نَيْسُ الْجَبَلِ				
8 water buffalo (Indian buffalo, water ox)	جَامُوسَةُ الْمَاءِ				
9 bison	النَّوْرُ الْأَمْرِيكِيُّ (الْبَيْسُونُ)				
10 musk ox	نُورُ الْمَسْكِ				
11-22 carnivores (beasts of prey)	أَكْلَاتُ الْحَيَوانِ (الْكُوبَسِرِ)				
11-13 Canidae	ذَوَاتُ الْأَنْبِيَابِ				
11 black-backed jackal (jackal)	ابْنُ أَرَبِي ذُو الظَّهْرِ الْأَسْوَدِ				
12 red fox	الثَّعْلَبُ الْأَحْمَرُ				
13 wolf	الذِّئْبُ				
14-17 martens	الْفَرَاشِيَّاتُ				
14 stone marten (beach marten)	الدَّلَقُ				
15 sable	السَّمُورُ				
16 weasel	ابْنُ عِرْسِ				
17 sea otter, an otter	ثَعْلَبُ الْبَحْرِ				
18-22 seals (pinnipeds)	زَعْفِيَّاتُ الْأَقْدَامِ				
18 fur seal (sea bear, ursine seal)	الْفَقْعَةُ				
19 common seal (sea calf, sea dog)	كَلْبُ الْبَحْرِ الْمَعْرُوفُ				
20 walrus (morse)	عِجَلُ الْبَحْرِ				
21 whiskers	شَوَارِبُ				
22 tusk	نَابٌ				
23-29 whales	الْحَيْتَانُ				
23 bottle-nosed dolphin (bottle-nose dolphin)	دَوْلْفِينٌ قَتِينِيَّ الْخَطَمِ				
24 common dolphin	دَوْلْفِينٌ مَعْرُوفٌ				
25 sperm whale (cachalot)	أَحَدُ مَخْطَرَايِ الْحَوْتِ				
26 blowhole (spout hole)	زَعْفَنَةُ ظَهْرِيَّةٌ				
27 dorsal fin	زَعْفَنَةُ الْحَوْتِ				
28 flipper	فَصَا ذَنْبِ الْحَوْتِ				
29 tail flukes (tail)					
368 Mammals III	الْمَذْبِيَّاتُ (3)				
1-11 carnivores (beasts of prey)	أَكْلَاتُ الْحَيَوانِ (الْكُوبَسِرِ)				
1 striped hyena, a hyena	الضَّبْعُ الْمَخْطُطُ				
2-8 felines (cats)	السَّمُورَاتُ				
2 lion	أَسَدٌ				
3 mane (lion's mane)	عُرْفُ الْأَسَدِ				
4 paw	مَخْطَبٌ				
5 tiger	نَمْرٌ، تَيْغٌ				
6 leopard	ضَبْعٌ، فَهْدٌ				
7 cheetah (hunting leopard)	فَهْدٌ هِنْدِيٌّ				
8 lynx	وَشَقٌ				
9-11 bears	الدَّبِيَّةُ				
9 raccoon (raccoon, Am. coon)	الرَّكَاكُونُ				
10 brown bear	الدَّبْيُ الْبَرِّيُّ				
11 polar bear (white bear)	الدَّبْيُ الْقَطْبِيُّ (الدَّبْيُ الْأَبْيَضُ)				
12-16 primates	الرِّبَاشِيَّاتُ				
12-13 monkeys	الْقُرُودُ				
12 rhesus monkey (rhesus, rhesus macaque)	قِرْدُ الرِّيْصِ				
13 baboon	الرَّبْيَاحُ، قِرْدُ الْبَابُونِ				
14-16 anthropoids (anthropoid apes, great apes)	أَشْيَاءُ الْإِنْسَانِ				
14 chimpanzee	الشمبانزي				
15 orang-utan	إِنْسَانُ الْعَاقِ				
16 gorilla	الغوريلا				
369 Deep-sea Fauna	أَحْيَاءُ أَعْمَاقِ الْبَحْرِ				
1 Gigantocypris agassizi	شَبُوطُ عَمَلَقِ				
2 Eupharynx	نُعْمَانٌ بَجْعِيٌّ				
pelecanoides (pelican eel, pelican fish)					
3 Metacrinus (feather star), ■ sea lily, an echinoderm	نَجْمٌ رِيْشِيٌّ				
4 Lycoteuthis diadema (jewelled squid), ■ cuttlefish [luminescent]	جَبَّارٌ، صَبِيْدٌ، سَبِيْبِيَا [مَضِي]				
5 Atolla, ■ deep-sea medusa, a coelenterate	قَنْدِيلُ الْبَحْرِ، رِبَّةُ الْبَحْرِ				
6 Melanocetes, ■ pediculate [luminescent]	أَبُو الشَّصْنِ، نَوْعٌ مِنَ الْعَطْفِيَّاتِ				
7 Lophocalyx philippensis, a glass	[مَضِي] إَسْفِنَجٌ كَسْبِيٌّ				

sponge		rays		54 ovary	مبيض	97-102 indehiscent fruits	ثمار مطيقة
8 Mopsea, a sea fan [colony]	مروحة البحر [مستعمرة]	12 sapwood (sap, albumum)	خشب أبيض، خشب الشح	55 style	قلم السمة، حامل السمة	97 berry	عنبية
9 Hydrallmania, a hydroid polyp, a coelenterate [colony]	زهرة البحر، غدار رنوبي، بوليبي هيدري [مستعمرة]	13 heartwood (duramen)	جلب، خشب القلب	56 stigma	سمة، ميسم	98 nut	جوزة نووية
10 Malacosteus indicus, a stomiatid [luminescent]	سمكة ملاكوستيوس المسوطة [مضيئة]	14 pith	نخاع، لب	57 stamen	سدانة	99 drupe (stone fruit) (cherry)	ثمرة علقية
11 Brisinga endecacnemus, a sand star (brittle star), an echinoderm [luminescent only when stimulated]	نجم الرمال، حيوان شوكي الجلد [مضيء عند حفزه]	15 plant	نبته	58 sepal	كأسية، فصلة	100 aggregate fruit (compound fruit) (rose hip)	ثمرة متضاعفة (توت شوكي)
12 Pasiphaea, a shrimp, a crustacean	إربيان، يرغوث البحر، صميري، حيوان قشري	16-18 root	جذر	59 petal	تويجة	101 aggregate fruit (compound fruit) (raspberry)	ثمرة متضاعفة (توت شوكي)
13 Echiostoma, a stomiatid, a fish [luminescent]	سمكة الاكستوما [مضيئة]	16 primary root	جذر رئيسي، عرقه	60 ovary and stamen [section]	المبيض والسداة [مقطع]	102 pome (apple)	ثمرة تفاحية
14 Umbellula encrinus, a sea pen (sea feather), a coelenterate [colony, luminescent]	انكريوس خيمي، ريشة البحر، حيوان لامعوي [مستعمرة، مضيء]	17 secondary root	جذر ثانوي	61 ovary wall	جدار المبيض	371 Deciduous Trees	أشجار نفضية
15 Polycheles, a crustacean	أم الإربيان، حيوان من القشريات	18 root hair	شعور جذرية	62 ovary cavity	تجويف المبيض	1-73 deciduous trees	أشجار نفضية
16 Lithodes, a crustacean, a crab	سوطان اللبؤوس، حيوان قشري	19-25 shoot (sprout)	فرع، وكرة، فسيلة	63 ovule	بيضة، بويضة	1 oak (oak tree)	البلوط
17 Archaster, a starfish (sea star), an echinoderm	كوكب البحر، نجم البحر، حيوان شوكي الجلد	19 leaf	ورقة	64 embryo sac	كيس الجنين	2 flowering branch	فرع مزهر
18 Oneirophanta, a sea cucumber, an echinoderm	أونايروفنتا، خيار البحر، حيوان شوكي الجلد	20 stalk	عناق	65 pollen	غبار الطلع، لقاح	3 fruiting branch	فرع مثمر
19 Palaeopneustes niasicus, a sea urchin (sea hedgehog), an echinoderm	قنعد البحر، حيوان شوكي الجلد	21 side shoot (offshoot)	فرع جانبي	66 pollen tube	غبار الطلع، لقاح	4 fruit (acorn)	ثمرة
20 Chitonactis, a sea anemone (actinia), a coelenterate	شعار البحر، شقيق البحر، حيوان لامعوي	22 terminal bud	برعم انتهائي	67-77 inflorescences	أشكال الإزهار، الفورات	5 cupule (cup)	كؤيس (كأس)
		23 flower	زهرة	67 spike (racemose spike)	سنبلة، سبلة، سنبله	6 female flower	زهرة مؤنثة
		24 flower bud	برعم الزهرة	68 raceme (simple raceme)	عقود	7 bract	قنابة
		25 leaf axil with axillary bud	محور الورقة مع برعم إضافي	69 panicle	عنقود	8 male inflorescence	إزهار ذكري
		26 leaf	ورقة	70 cyme	سنبلة، قبة	9 birch (birch tree)	بتولا، شجرة القضبان
		27 leaf stalk (petiole)	عناق الورقة	71 spadix (fleshy spike)	طلع	10 branch with catkins, a flowering branch	فرع وعليه القذات
		28 leaf blade (blade, lamina)	نصل الورقة	72 umbel (simple umbel)	خيمة	11 fruiting branch	فرع مثمر
		29 venation (veins, nervures, ribs)	عروق، تعريق	73 capitulum	رؤيس	12 scale (catkin scale)	حراشفة
		30 midrib (nerve)	عرو، صلغ	74 composite head (discoid flower head)	رأس مركب	13 female flower	زهرة مؤنثة
		31-38 leaf shapes	أشكال الورقة	75 hollow flower head	رأس زهرة مجوف	14 male flower	زهرة مذكرة
		31 linear	خطية	76 bostryx (helicoid cyme)	سنبلة حلزونية	15 poplar	جوزة
		32 lanceolate	سناية	77 cincinnus (scorpioid cyme, curled cyme)	سنبلة مقوسة	16 flowering branch	فرع مزهر
		33 orbicular (orbiculate)	دائرية	78-82 roots	الجذور	17 flower	زهرة
		34 acerose (acerous, acerate, acicular, needle-shaped)	إبرية	78 adventitious roots	جذر عرضي/طارئ	18 fruiting branch	فرع مثمر
		35 cordate	قلبية	79 tuber (tuberous root, swollen taproot)	عسقل، عسقول	19 fruit	ثمرة
		36 ovate	بيضوية	80 adventitious roots (aerial roots)	جذور عرضية	20 seed	حبة، بذرة
		37 sagittate	سهامية	81 root thorns	شوك الجذر	21 leaf of the aspen (trembling poplar)	ورقة حور رجراج
		38 reniform	كلوية	82 pneumatophores	حوامل رنوية	22 infructescence	عقود ثمر
		39-42 compound leaves	أوراق مركبة	83-85 blade of grass	نصل الخيليات	23 leaf of the white poplar (silver poplar, silverleaf)	ورقة حور أبيض
		39 digitate (digitated, palmate, quinque-foliolate)	ورقة مصنعة	83 leaf sheath	قاعدة مغلاق الورقة	24 willow (goat willow)	صنغاف السعز
		40 pinnatifid	ورقة ريشية الإنشاق	84 ligule (ligula)	لسين	25 branch with flower buds	فرع وعليه براعم الزهور
		41 abruptly pinnate	ورقة ريشية متفجرة	85 leaf blade (lamina)	نصل الورقة	26 catkin with single flower	قبة وحيدة الزهرة
		42 odd-pinnate	ورقة ريشية مفردة	86 embryo (seed, germ)	جنين	27 branch with leaves	فرع مورق
		43-50 leaf margin shapes	أشكال حافة الورقة	87 cotyledon (seed leaf, seed lobe)	بذرة، فلقه	28 fruit	ثمرة
		43 entire	كاملة/عساة	88 radicle	جذير	29 osier branch with leaves	فرع صنغاف السلالين
		44 serrate (serrulate, saw-toothed)	مبشارية	89 hypocotyl	سويق الجنين	30 alder	جار الماء
		45 doubly toothed	زوجية الأسنان	90 plumule (leaf bud)	ساق جنينية	31 fruiting branch	فرع مثمر
		46 crenate	مفروضة/مشرفة	91-102 fruits	ثمار	32 branch with previous year's cone	فرع وبه صنوبريات العام السابق
		47 dentate	مسنتة	91 follicle	ثمار متفتحة	33 beech (beech tree)	شجرة الزان
		48 sinuate	تمسجة	92 legume (pod)	ثمرة جرابية	34 flowering branch	فرع مزهر
		49 ciliate (ciliated)	مهدبة	93 siliqua (pod)	ثمرة قرن، حبة	35 flower	زهرة
		50 cilium	هدب	94 schizocarp	ثمرة شققة الجيا، علية	36 fruiting branch	فرع مثمر
		51 flower	زهرة	95 pyxidium	ثمرة شققة الجيا، علية	37 beech nut	ثمرة الزان
		52 flower stalk (flower stem, scape)	عناق الزهرة				
		53 receptacle (floral axis, thalamus, torus)	قوس/كروسي الزهرة	96 pericidal capsule (porose capsule)	علية مسامية		

38 ash (ash tree)	شجرة العُرَّان
39 flowering branch	فرع مزهر
40 flower	زهرة
41 fruiting branch	فرع مثمر
42 mountain ash (rowan, quickbeam)	شجرة السمن
43 inflorescence	نظام الإزهار
44 infructescence	عنقود ثمر
45 fruit [longitudinal section]	ثمرة [مقطع طولي]
46 lime (lime tree, linden, linden tree)	شجرة الزيزفون
47 fruiting branch	فرع مثمر
48 inflorescence	نظام الإزهار
49 elm (elm tree)	بوقصيا، شجرة البق
50 fruiting branch	فرع مثمر
51 flowering branch	فرع مزهر
52 flower	زهرة
53 maple (maple tree)	شجرة القيقب
54 flowering branch	فرع مزهر
55 flower	زهرة
56 fruiting branch	فرع مثمر
57 maple seed with wings (winged maple seed)	بذرة قيقب جناحية
58 horse chestnut (horse chestnut tree, chestnut, chestnut tree, buckeye)	قسطلة الهند، قسطل الحصان
59 branch with young fruits	فرع وبه بؤادر الثمار
60 chestnut (horse chestnut)	قسطل، كسكتة
61 mature (ripe) fruit	ثمرة يابسة
62 flower [longitudinal section]	زهرة [مقطع طولي]
63 hornbeam (yoke elm)	شجرة البئر، نيريبة شائعة
64 fruiting branch	فرع مثمر
65 seed	حبة، بذرة
66 flowering branch	فرع مزهر
67 plane (plane tree)	دلب، صنار
68 leaf	ورقة
69 infructescence and fruit	عنقود ثمر وثمره
70 false acacia (locust tree)	روبيبية شائعة، سطل كاذب
71 flowering branch	فرع مزهر
72 part of the infructescence	جزء من عنقود الثمر
73 base of the leaf stalk with stipules	قاعدة ساق الورقة وبها اذنات
372 Conifers	الصنوبريات
1-71 coniferous trees (conifers)	الأشجار الصنوبرية
1 silver fir (European silver fir, common silver fir)	ثوب منسحب، ثوب مبسطي
2 fir cone, a fruit cone	صنوبرية الثوب
3 cone axis	محور الصنوبرية
4 female flower cone	صنوبرية زهرة مؤنثة
5 bract scale (bract)	قنابة

6 male flower shoot	قسيلة زهرة مذكرة
7 stamen	سداة
8 cone scale	حراشفة الصنوبرية
9 seed with wing (winged seed)	بذرة جناحية
10 seed [longitudinal section]	بذرة (حبة) [مقطع طولي]
11 fir needle (needle)	ورقة الثوب الخيطية
12 spruce (spruce fir)	راتنجية عالية
13 spruce cone	صنوبرية الراتنجية العالية
14 cone scale	حراشفة الصنوبرية
15 seed	بذرة، حبة
16 female flower cone	صنوبرية زهرة مؤنثة
17 male inflorescence	شكل إزهار ذكري
18 stamen	سداة
19 spruce needle	ورقة الراتنجية الخيطية
20 pine (Scots pine)	صنوبر (صنوبر اسكتلندي)
21 dwarf pine	صنوبر قزمي
22 female flower cone	صنوبرية زهرة مؤنثة
23 short shoot with bundle of two leaves	قسيلة قصيرة ذات ورقتين
24 male inflorescences	أشكال إزهار ذكري
25 annual growth	نماء سنوي
26 pine cone	صنوبرية الصنوبر
27 cone scale	حراشفة الصنوبرية
28 seed	بذرة، حبة
29 fruit cone of the arolla pine (Swiss stone pine)	صنوبرية ثمرة الصنوبر السويسري
30 fruit cone of the Weymouth pine (white pine)	صنوبرية ثمرة الصنوبر الأبيض
31 short shoot [cross section]	قسيلة قصيرة [مقطع عرضي]
32 larch	أرزينة
33 flowering branch	فرع مزهر
34 scale of the female flower cone	حراشفة صنوبرية زهرة مؤنثة
35 anther	مثير، منيار
36 branch with larch cones (fruit cones)	فرع وعليه صنوبريات الأرزينة
37 seed	بذرة، حبة
38 cone scale	حراشفة الصنوبرية
39 arbor vitae (tree of life, thuja)	شجرة الحياة، عفسية
40 fruiting branch	فرع مثمر
41 fruit cone	صنوبرية الثمرة
42 scale	حراشفة
43 branch with male and female flowers	فرع وبه أزهار مذكرة ومؤنثة
44 male shoot	قسيلة مذكرة
45 scale with pollen sacs	حراشفة وعليها أكياس اللقاح
46 female shoot	قسيلة مؤنثة
47 juniper (juniper tree)	شجرة العرعر
48 female shoot [longitudinal section]	قسيلة مؤنثة [مقطع طولي]
49 male shoot	قسيلة مذكرة
50 scale with pollen sacs	حراشفة وعليها أكياس اللقاح

51 fruiting branch	فرع مثمر
52 juniper berry	ثمرة العرعر
53 fruit [cross section]	ثمرة [مقطع عرضي]
54 seed	بذرة، حبة
55 stone pine	صنوبر مثمر
56 male shoot	قسيلة مذكرة
57 fruit cone with seeds [longitudinal section]	صنوبره الثمرة وبها البذور [مقطع طولي]
58 cypress	السرو
59 fruiting branch	فرع مثمر
60 seed	بذرة، حبة
61 yew (yew tree)	الطقسوس
62 male flower shoot and female flower cone	قسيلة زهرة مذكرة وصنوبرية زهرة مؤنثة
63 fruiting branch	فرع مثمر
64 fruit	ثمرة
65 cedar (cedar tree)	شجرة الأرز
66 fruiting branch	فرع مثمر
67 fruit scale	حراشفة الثمرة
68 male flower shoot and female flower cone	قسيلة زهرة مذكرة وصنوبرية زهرة مؤنثة
69 mammoth tree (Wellingtonia, sequoia)	جبارة، سكوية
70 fruiting branch	فرع مثمر
71 seed	بذرة، حبة
373 Ornamental Shrubs and Trees I	جنيات وأشجار الزينة (I)
1 forsythia	فرسيثية
2 ovary and stamen	المبيض والسداة
3 leaf	ورقة
4 yellow-flowered jasmine (jasmin, jessamine)	الياسمين الأصفر
5 flower [longitudinal section] with styles, ovaries, and stamens	زهرة [مقطع طولي] وبها أقلام النسب والمبايض والأشدية
6 privet (common privet)	جنية الرباط، ليقتسزوم
7 flower	زهرة
8 infructescence	عنقود ثمر
9 mock orange (sweet syringa)	فيلدالس إكليلي
10 snowball (snowball bush, guelder rose)	كررة الثلج، خسان الماء
11 flower	زهرة
12 fruits	ثمار
13 oleander (rosebay, rose laurel)	دقلى، آلاء
14 flower [longitudinal section]	زهرة [مقطع طولي]
15 red magnolia	مغولية حمراء
16 leaf	ورقة
17 japonica (japanese quince)	يابانية
18 fruit	ثمرة
19 common box (box, box tree)	بقس شائع
20 female flower	زهرة مؤنثة
21 male flower	زهرة مذكرة
22 fruit [longitudinal section]	ثمرة [مقطع طولي]
23 weigela (weigelia)	ويغلة
24 yucca [part of the inflorescence]	يكة
25 leaf	ورقة
26 dog rose (briar rose, wild briar)	شبرين بري
27 fruit	ثمرة
28 kerria	كرية
29 fruit	ثمرة
30 cornelian cherry	قرانيا معروفة
31 flower	زهرة
32 fruit (cornelian cherry)	ثمرة
33 sweet gale (gale)	شمعية عطرية
374 Ornamental Shrubs and Trees II	جنيات وأشجار الزينة (2)
1 tulip tree (tulip poplar, saddle tree, whitewood)	شجرة الزنبق
2 carpels	أخدية
3 stamen	سداة
4 fruit	ثمرة
5 hyssop	زؤفا، إشتان داود
6 flower [front view]	زهرة [منظر أمامي]
7 flower	زهرة
8 calyx with fruit	كاس مع ثمرة
9 holly	بهشية، إيلكس
10 androgynous (hermaphroditic, hermaphrodite) flower	زهرة خنثى
11 male flower	زهرة مذكرة
12 fruit with stones exposed	ثمرة وأنوثة مكشوفة
13 honeysuckle (woodbine, woodbind)	سلطان الجبل، شبر فايد
14 flower buds	براعم الزهور
15 flower [cut open]	زهرة [مشقوفة]
16 Virginia creeper (American ivy, woodbine)	ليلاية عذراء
17 open flower	زهرة مفتحة
18 infructescence	عنقود ثمر
19 fruit [longitudinal section]	ثمرة [مقطع طولي]
20 broom	قو طيسون، رتم المكاس
21 flower with the petals removed	زهرة نزع منها البتلات/التويجات
22 immature (unripe) legume (pod)	بقلة لم تنضج بعد
23 spiraea	إكليل، إسبيرية
24 flower [longitudinal section]	زهرة [مقطع طولي]
25 fruit	ثمرة
26 carpel	خباء
27 blackthorn (sloe)	برقوق شاك
28 leaves	أوراق
29 fruits	ثمار

30 single-pistilled hawthorn (thorn, may)	زَعُورٌ وحيد البِدْقَة	(flower of inner series)	نسق داخلي)	24 crane's bill	إبرة الراعي	berry); <i>sim.</i> : cowberry	المنافع والحجيرية
31 fruit	فَمْرَة	33 involucreal calyx with pappus bristles	كأس قنابي مع شعيرات شوكية مظلية	25 wild chicory (witloof, succory, wild endive)	هَيْدِيَا بَرِيَّة	(red whortleberry), bog bilberry (bog whortleberry), crowberry (crakeberry)	
32 laburnum (golden chain, golden rain)	سَيْتِيْس، قَوَطِيْسوس	34 ovary with pappus	مبيض وطلا، شعيرات ناشرة	26 common toadflax (butter-and-eggs)	كَنَابِيَّة شائعة		
33 raceme	عَنْقود	35 fruit	فَمْرَة	27 lady's slipper (Venus's slipper, <i>Am. moccasin flower</i>)	خَف السَّيْدَة، مِجْرَاعَة الحدائق		
34 fruits	ثَمَار	36 lesser celandine	عُشْبَة البواسير	28 orchis (wild orchid), an orchid	سَلْطَب (خَمْسِي الثَّطْب)		
35 black elder (elder)	خَمَان أسود	37 fruit	فَمْرَة	377 Plants of Forest, Marsh, and Heathland	نَبَاتَات الأَحْرَاج والمُسْتَنْقَعَات والبَرَاحَات	378 Alpine Plants, Aquatic Plants (Water Plants), and Marsh Plants	النَّبَاتَات الأَلْبِيَّة ونباتات الماء ونباتات المستنقعات
36 elder flowers	زهور الخمان	38 leaf axil with bulbil	محزور ورقة ذو بصيلة	1 wood anemone (anemone, windflower)	شَفَار حَرَجِي	1-13 alpine plants	النَّبَاتَات الأَلْبِيَّة
37 elderberries	عَنْبِيَّات الخمان	39 annual meadow grass	عُشْبَة الكَلَا زَهْرَة	2 lily of the valley	زَيْق الوادي	1 alpine rose (alpine rhododendron)	ورد ألبى
375 Meadow Flowers and Wayside Flowers (Wild Flowers) I	أَزْهَار المراعِي والأزهار البرية (1)	40 flower	سَيْتِيَلَة [منظر جانبي]	3 cat's foot (milkwort); <i>sim.</i> : sandflower (everlasting)	رَجُل الهَر (مُسْتَدْرَة)؛ مَطْهَا زَهْرَة الرَّمَال (مُخَلَّطَة)	2 flowering shoot	فَرْع مَزْهَر
1 rotundifoliate (rotundifolious) saxifrage (rotundifoliate breakstone)	كاسر الحجر المستدير الورق	41 spikelet [side view]	سَيْتِيَلَة [منظر أمامي]	4 turk's cap (turk's cap lily)	زَيْق مَوْتَاغُون	3 alpine soldanella (soldanella)	سولدانيلا ألبية
2 leaf	وَرَقَة	42 spikelet [front view]	سَيْتِيَلَة [منظر أمامي]	5 goatsbeard (goat's beard)	لِحْيَة التَّيْس	4 corolla opened out	تويج مفتوح
3 flower	زَهْرَة	43 caryopsis, an indehiscent fruit	بُرَة	6 ramson	مُوم الدَّبِيَّة	5 seed vessel with the style	وعاء البذرة والنسيم
4 fruit	فَمْرَة	44 tuft of grass (clump of grass)	حزمة عشبية	7 lungwort	حَشِيشَة الرُّمَة	6 alpine wormwood	أَسْتِيْن أَلْبِي
5 anemone (windflower)	شَفَانِق النعمان	45 comfrey	سَقِيْتُون	8 corydalis	قَيْرِيَّة	7 inflorescence	شكل إزهار
6 flower [longitudinal section]	زَهْرَة [مَقْطَع طولي]	46 flower [longitudinal section]	زَهْرَة [مَقْطَع طولي]	9 opine (livelong)	مُخَلَّطَة	8 auricula	زَهْرَة الربيع الأذينية
7 fruit	فَمْرَة	47 fruit	فَمْرَة	10 daphne	دَفْنَة	9 edelweiss	بَرْسِيَّة الأَلْبِي
8 buttercup (meadow buttercup, butterflower, goldcup, king cup, crowfoot)	حَوْدَان	376 Meadow Flowers and Wayside Flowers (Wild Flowers) II	أَزْهَار المراعِي والأزهار البرية (2)	11 touch-me-not	زَهْرَة لَا تَمَسَّنِي، المَسْتَحِيَة	10 flower shapes	أَشْكَال الزَهْرَة
9 basal leaf	ورقة قاعدية	1 daisy (<i>Am. English daisy</i>)	زَهْرَة الربيع، مَرْغَرِيْنَا	12 staghorn (stag horn moss, stag's horn, stag's horn moss, coral evergreen)	قَرْن الأَيْل	11 fruit with pappus tuft	فَمْرَة ذات حزمة خيوط شعيرية مظلية
10 fruit	فَمْرَة	2 flower	زَهْرَة	13 butterwort, an insectivorous plant	نَبَات أَكَل للحشرات	12 part of flower head (of capitulum)	جزء من رأس زهرة
11 lady's smock (lady-smock, cuckoo flower)	حَرْف المَاء، حَرْف المَرْج	3 fruit	فَمْرَة	14 sundew; <i>sim.</i> : Venus's flytrap	دوروسيرة	13 stemless alpine gentian	جَنْطِيَانَا أَلْبِيَة عَدِيمَة الساق
12 basal leaf	ورقة قاعدية	4 oxeye daisy (white oxeye daisy, marguerite)	أَقْحَوَان المَرْوَج	15 bearberry	عَنْب الدب	14-57 aquatic plants (water plants) and marsh plants	النَّبَاتَات المَائِيَّة ونباتات المنافع
13 fruit	فَمْرَة	5 flower	زَهْرَة	16 polyphy (polypod), a fern; <i>sim.</i> : male fern, brake (bracken, eagle fern), royal fern (royal osmund, king's fern, ditch fern)	بَسْفَاج، نوع من السرخسيات، مثله سَرْخَس ذَكَر، أَسْمَلْدَة مَلَوَكِيَة	14 white water lily	نَيْلُوفَر أبيض
14 harebell (hairbell, bluebell)	جُرَيْس مستدير الورق	6 fruit	فَمْرَة	17 haircap moss (hair moss, golden maiden-hair), a moss	نَبَات أَكَل للحشرات	15 leaf	ورقة
15 basal leaf	ورقة قاعدية	7 masterwort	بَقْلَة الرِّيس، هِرْقَلِيَّة صُوفِيَّة	18 cotton grass (cotton rush)	كَنْان المنافع	16 flower	زَهْرَة
16 flower [longitudinal section]	زَهْرَة [مَقْطَع طولي]	8 cowslip	أَدْرِيُون المَاء، زَهْرَة الربيع العَرَجِيَّة	19 heather (heath, ling); <i>sim.</i> : bell heather (cross-leaved heather)	خَلْخ؛ مثله زَهْرَة الخَلْخ	17 Queen Victoria water lily (Victoria regia water lily, royal water lily, Amazon water lily)	زَيْق فِكْتُورِيَا، فِكْتُورِيَة مَلَكِيَّة، ذُرَة المَاء
17 fruit	فَمْرَة	9 great mullein (Aaron's rod, shepherd's club)	أَدَان الدُّب، بُوَصِير	20 rock rose (sun rose)	زَهْرَة الشَّمْس	18 leaf	ورقة
18 ground ivy (ale hoof)	نَبْلَاب اَرْضِي	10 bistort (snakeweed)	جَنْجَر مَلَو (عُشْبَة الأَقْعِي)	21 marsh tea	شاي المنافع	19 underside of the leaf	الجانب السفلي للورقة
19 flower [longitudinal section]	زَهْرَة [مَقْطَع طولي]	11 flower	زَهْرَة	22 sweet flag (sweet calamus, sweet sedge)	وَج، عِرَق أَكْر، أَقْوَرُون	20 flower	زَهْرَة
20 flower [front view]	زَهْرَة [منظر أمامي]	12 knapweed	قَنْطَرِيُون أسود	23 bilberry (whortleberry, huckleberry, blue-	عَنْب الأَحْرَاج، أُوَيْسَة ومثله عنبة جبلية، وعنبة	21 reed mace bulrush (cattail, cat's tail, cattail flag, club rush)	نَيْفَا عَرِيضَة الورق، عُشْبَة البرك
21 stonecrop	سِيْدُوم، حَي العالم	13 common mallow	فَمْرَة			22 male part of the spadix	الجزء الذكري للطلع
22 speedwell	زَهْرَة الحَوَاشِي، وَيَزُونِيَكَة	14 fruit	فَمْرَة			23 male flower	زَهْرَة مذكرة
23 flower	زَهْرَة	15 yarrow	أَخِيلَة ذات أَلْف وَرَقَة			24 female part	جزء مؤنث
24 fruit	فَمْرَة	16 self-heal	زَهْرَة التَّام دَاتِي			25 female flower	زَهْرَة مؤنثة
25 seed	بَذْرَة، حبة	17 bird's foot trefoil (bird's foot clover)	قَرْن الغَزَال، لُوطَس قَرْنِي			26 forget-me-not	أَذْن الفَار
26 moneywort	بَذْرَة، حبة	18 horsetail (equisetum) [a shoot]	كَنْبَات، ذَنْب الخَيْل [فَسِيلَة]			27 flowering shoot	فَرْع مَزْهَر
27 dehiscent fruit	فَمْرَة مُتَفَتِحَة	19 flower (strobile)	زَهْرَة (مخروط)			28 flower [section]	زَهْرَة [مَقْطَع]
28 seed	بَذْرَة، حبة	20 campion (catchfly)	سَلْيُوس، مَيْتُور بَرِي (لَحْمِيْس النَّبَات)			29 frog's bit	كَلُوه المَاء
29 small scabious	إِسْكِيُونِيَزَة، زَهْرَة الجَرْب	21 ragged robin (cuckoo flower)	زَهْرَة الوَلُوقَاق			30 watercress	قَرَة العَيْن
30 basal leaf	ورقة قاعدية	22 birthwort	زَرَاوَنْد			31 stalk with flowers and immature (unripe) fruits	ساق عليها أوراق وثمار غير ناضجة
31 ray floret (flower of outer series)	زَهْيَرَة شَعَاعِيَّة (زَهْرَة ذات نسق خارجي)	23 flower	زَهْرَة			32 flower	زَهْرَة
32 disc (disk) floret	زَهْيَرَة قَرَصِيَّة (زَهْرَة ذات					33 siliqua (pod) with	خَرْدَلِيَّة بها حبوب

seeds	حَبَّان
34 two seeds	حَبَّان
35 duckweed (duck's meat)	عَدَسُ الْمَاءِ
36 plant in flower	نَبْتَةٌ فِي زَهْرَةٍ
37 flower	زَهْرَةٌ
38 fruit	فَرَاغٌ ذُو أَزْهَارٍ وَشَارِ
39 flowering rush	أَسَلٌ مَزْهَرٌ ، سَمَارُ مَزْهَرٍ
40 flower umbel	خِيَمَةُ الزَّهْرَةِ
41 leaves	أُورَاقٌ
42 fruit	شَمْرَةٌ
43 green alga	طَحْلِبُ خَضِرٍ ، أَشْتَةُ خَضِرَاءَ
44 water plantain	مَرْشَارُ الرَّاعِي ، آذَانُ الْعَنْزِ
45 leaf	وَرَقَةٌ
46 panicle	عَنَّكُولٌ
47 flower	زَهْرَةٌ
48 honey wrack, a brown alga	طَحْلِبُ الْفَرْقَسِ ، طَحْلِبُ أَسْمَرٍ
49 thallus (plant body, frond)	مَشْرَةٌ ، ثَالُوسٌ
50 holdfast	مُثَبِّتٌ
51 arrow head	سَهْمِيَّةٌ
52 leaf shapes	أَشْكَالُ الْوَرَقَةِ
53 inflorescence with male flowers [above] and female flowers [below]	شَكْلُ إِزْهَارٍ مَعَ زَهْوَرٍ مَذَكْرَةٍ [أَعْلَى] وَزَهْوَرٍ مَوْثِقَةٍ [أَسْفَلَ]
54 sea grass	كَلَّالُ الْبَحْرِ
55 inflorescence	شَكْلُ إِزْهَارٍ
56 Canadian waterweed (Canadian pondweed)	عَشْبٌ مَائِيٌّ كَنْدِيٌّ
57 flower	زَهْرَةٌ

379 Poisonous Plants

1 aconite (monkshood, wolfsbane, helmet flower)	أَفُوتِينٌ ، بَيْشٌ
2 foxglove (Digitalis)	قَمِيصِيَّةٌ ، دِيَجِيَّتَالِيْسٌ
3 meadow saffron (naked lady, naked boys)	سَوْرَنْجَانُ الْخَرِيفِ ، أَصَابِعُ هَرْمِسٍ
4 hemlock (Conium)	شَوْكْرَانُ كَبِيرٍ
5 black nightshade (common nightshade, petty morel)	مَعْدُ أَسْوَدٌ ، حَبَّانٌ
6 henbane	بَنْجٌ أَسْوَدٌ
7 deadly nightshade (belladonna, banewort, dwale), a solanaceous herb	بِلَادُونَا سَامَةٌ
8 thorn apple (stramonium, stramony, Am. jimson weed, jimpson weed, Jamestown weed, stinkweed)	دَائُورَةٌ ، دَائُورَةٌ مَثْبِتَةٌ ، عَشْبَةٌ جِيْمْسُونٌ
9 cuckoo pint (lords-and-ladies, wild arum, wake-robin)	لُوفٌ أَيْقَعٌ
10-13 poisonous fungi	طَحَالِبٌ سَامَةٌ (عش غراب

(poisonous mushrooms, toadstools)	سَامٌ
10 fly agaric (fly amanita, fly fungus), an agaric	غَارِيْقُونُ الذَّبَابِ (أَمَانِيْتِ الْذَّبَابِ)
11 amanita	أَمَانِيْتٌ
12 Satan's mushroom	فَطْرُ الشَّيْطَانِ
13 woolly milk cap	قَبْعَةُ اللَّبَنِ الصُّوفِيَّةِ

380 Medicinal Plants

1 camomile (chamomile, wild camomile)	نَبَاتَاتٌ طَبِيْعِيَّةٌ الْبَابُونَجِ ، بَهَارُ نَبِيلٍ
2 arnica	زَهْرَةُ الْعَطَاسِ
3 peppermint	نَعْنَعٌ بَسْتَانِيٌّ
4 wormwood (absinth)	أَسْتِسْتِينٌ ، شَبِجٌ
5 valerian (allheal)	نَارْدِينٌ ، سَنْبَلٌ
6 fennel	شَمَارٌ ، شَمْرَةٌ
7 lavender	خَرَامِيٌّ
8 coltsfoot	خَشِيْشَةُ السَّعَالِ
9 tansy	خَشِيْشَةُ الدَّوْدِ/السَّفَاءِ
10 centauray	قَنْطَرِيُونٌ صَغِيرٌ
11 ribwort (ribwort plantain, ribgrass)	إِسَانُ الْحَمَلِ السَّنَانِيِّ
12 marshmallow	خَطْمِيٌّ مَخْرَنْجِيٌّ ، عَسُولٌ جِلْمُهُ ، عَوْسَجٌ أَسْوَدٌ
13 alder buckthorn (alder dogwood)	خَرْجُوعٌ مَعْرُوفٌ
14 castor-oil plant (Palma Christi)	خَشْمَاشٌ مُمَوَّمٌ
15 opium poppy	سَنَا ، سَنِّيُّ الْوَرِيْقَاتِ الْمَحْجِفَةُ أَوْرَاقِ السَّنَا
16 senna (cassia); the dried leaflets: senna leaves	كِينَا كَافُورٌ
17 cinchona (cinchona)	فَوْقَلٌ ، كَوْتَلٌ
18 camphor tree (camphor laurel)	شَمْرَةُ الْفَوْقَلِ ، شَمْرَةُ الْكَوْتَلِ

381 Edible Fungi (Esculent Fungi)

1 meadow mushroom (field mushroom)	فَطْرُ زَرَاعِيٌّ
2 mycelial threads (hyphae, mycelium) with fruiting bodies	غَزَلٌ فَطْرِيٌّ بِجِسِمَاتٍ مُثَمَّرَةٍ
3 mushroom [longitudinal section]	فَطْرٌ ، غَارِيْقُونٌ [مَقْطَعٌ طَوَّلِيٌّ]
4 cap (pileus) with gills	قَبْعَةٌ فَطْرٍ ذَاتِ خِيَاشِيمٍ
5 veil (velum)	بَرِيقٌ
6 gill [section]	خَشِيْمٌ [مَقْطَعٌ]
7 basidia [on the gill with basidiospores]	دَعَامَاتٌ [عَلَى الْخِيْشُومِ وَهِيَ أُنْوَاغٌ دَعَامِيَّةٌ]
8 germinating basidiospores (spores)	أُبُوَاغٌ دَعَامِيَّةٌ نَابِئَةٌ
9 truffle	كَمْهٌ
10 truffle [external view]	كَمْهٌ [مَنْظَرٌ خَارِجِيٌّ]
11 truffle [section]	كَمْهٌ [مَقْطَعٌ]
12 interior showing asci [section]	زِقَاقٌ مِنَ الدَّاخِلِ [مَقْطَعٌ]

13 two asci with the ascospores (spores)	زِقَاقَانِ أَبُوَاغٍ زَيْفِيَّةٍ
14 chanterelle (chantarelle)	الْإِنَائِيَّةُ ، فَطْرٌ يُوَكَّلُ
15 Chestnut Boletus	فَطْرُ بُولِيْتَسِ
16 cep (cepe, squirrel's bread, Boletus edulis)	خَبَزُ السَّقَابِ (بُولِيْتَسِ مَأْكُولٌ)
17 layer of tubes (hymenium)	طَبَقَةٌ مِنَ الْأَنْبَابِيْبِ (عَشْيِيٌّ)
18 stem (stipe)	عَنْقٌ (سَوِيْقٌ)
19 puffball (Bovista nigrescens)	فَقْعُ الذَّبِّ
20 devil's tobacco pouch (common puffball)	فَقْعٌ شَائِعٌ
21 Brown Ring Boletus (Boletus luteus)	فَطْرُ بُولِيْتَسِ ذُو الْحَلْقَةِ النَبِيْئَةِ
22 Birch Boletus (Boletus scaber)	بُولِيْتَسِ قَاسٍ
23 Russula vesca	إِنَائِيَّةٌ مَعْرُوفَةٌ
24 scaled prickle fungus	فَطْرٌ أِبْرِيٌّ حَرَشْفِيٌّ
25 slender funnel fungus	فَطْرٌ قَيْمَعِيٌّ لِحْلِيٌّ
26 morel (Morchella esculenta)	غَوْشَةٌ (فَطْرٌ صَالِحٌ لِلْأَكْلِ)
27 morel (Morchella conica)	غَوْشَةٌ (فَطْرٌ مَخْرُوطِيٌّ الشَّكْلِ)
28 honey fungus	فَطْرُ الْجَذْوَرِ الْعَصْلِيِّ
29 saffron milk cap	لَبِيْئَةٌ لَذِيْبَةٌ
30 parasol mushroom	فَطْرٌ مِثْلِيٌّ
31 hedgehog fungus (yellow prickle fungus)	فَطْرٌ قَنْفَدِيٌّ
32 yellow coral fungus (goatsbeard, goat's beard, coral Clavaria)	دَبُوسِيَّةٌ مَرْجَابِيَّةٌ
33 little cluster fungus	فَطْرٌ عَنَقُوْدِيٌّ

382 Tropical Plants used as Stimulants, Spices, and Flavoring

1 coffee tree (coffee plant)	شَجَرَةُ الْبِنِّ
2 fruiting branch	فَرْعٌ مَثْمِرٌ
3 flowering branch	فَرْعٌ مَزْهَرٌ
4 flower	زَهْرَةٌ
5 fruit with two beans [longitudinal section]	شَمْرَةٌ مِنْ فَلَاقَتَيْنِ [مَقْطَعٌ طَوَّلِيٌّ]
6 coffee bean; when processed: coffee	حَبَّةُ الْبِنِّ ، عِنْدَ تَصْنِيْعِهَا بِنٌّ ، قَهْوَةٌ
7 tea plant (tea tree)	شَجَرَةُ الشَّايِ
8 flowering branch	فَرْعٌ مَزْهَرٌ
9 tea leaf; when processed: tea	وَرَقَةٌ الشَّايِ ، عِنْدَ تَصْنِيْعِهَا شَايٌ
10 fruit	شَمْرَةٌ
11 maté shrub (maté, yerba maté, Paraguay tea)	شَايٌ بَرِغُوَايِيٌّ
12 flowering branch with androgynous (hermaphroditic, hermaphrodite) flowers	فَرْعٌ مَزْهَرٌ ذُو أَزْهَارٍ حُتْنِيٍّ

13 male flower	زَهْرَةٌ ذَكَرٌ
14 androgynous (hermaphroditic, hermaphrodite) flower	زَهْرَةٌ حُتْنِيٌّ
15 fruit	شَمْرَةٌ
16 cacao tree (cacao)	شَجَرَةُ الْكَكَائُو
17 branch with flowers and fruits	فَرْعٌ ذُو أَزْهَارٍ وَشَارِ
18 flower [longitudinal section]	زَهْرَةٌ [مَقْطَعٌ طَوَّلِيٌّ]
19 cacao beans (cocoa beans); when processed: cocoa, cocoa powder	حَبَّةُ الْكَكَائُو ؛ عِنْدَ تَصْنِيْعِهَا كَكَائُو
20 seed [longitudinal section]	بَذْرَةٌ [مَقْطَعٌ طَوَّلِيٌّ]
21 embryo	جَلِيْنٌ
22 cinnamon tree (cinnamon)	شَجَرَةُ الْقَرْفَةِ
23 flowering branch	فَرْعٌ مَزْهَرٌ
24 fruit	شَمْرَةٌ
25 cinnamon bark; when crushed: cinnamon	لِحَاءُ الْقَرْفَةِ ؛ عِنْدَ طَحْنِهَا قَرْفَةٌ
26 clove tree	شَجَرَةُ الْقَرْفَلِ
27 flowering branch	فَرْعٌ مَزْهَرٌ
28 flower bud; when dried: clove	بُرْعَمُ الزَّهْرَةِ ؛ عِنْدَ تَجْفِيْفِهِ قَرْفَلٌ
29 flower	زَهْرَةٌ
30 nutmeg tree	جُوزُ الطَّيْبِ ، بَسْبَاسَةٌ
31 flowering branch	فَرْعٌ مَزْهَرٌ
32 female flower	زَهْرَةٌ أُنْثَى [مَقْطَعٌ طَوَّلِيٌّ]
33 mature (ripe) fruit	شَمْرَةٌ نَاضِجَةٌ
34 nutmeg with mace, a seed with lacinate aril	جُوزَةُ الطَّيْبِ ذَاتُ زَيْتٍ
35 seed [cross section]; when dried: nutmeg	حَبَّةٌ ، بَذْرَةٌ [مَقْطَعٌ عَرْضِيٌّ] عِنْدَ تَجْفِيْفِهَا جُوزُ الطَّيْبِ
36 pepper plant	فَطْلَقٌ
37 fruiting branch	فَرْعٌ مَثْمِرٌ
38 inflorescence	شَكْلُ الْأَزْهَارِ
39 fruit [longitudinal section] with seed (peppercom); when ground: pepper	شَمْرَةٌ [مَقْطَعٌ طَوَّلِيٌّ] ذَاتُ بَذْرَةٍ ؛ عِنْدَ طَحْنِهَا فَطْلَقٌ
40 Virginia tobacco plant	تَبَاقُ فَرِجِينِيَّةٌ
41 flowering shoot	عَصْبٌ مَزْهَرٌ
42 flower	زَهْرَةٌ
43 tobacco leaf; when cured: tobacco	وَرَقَةٌ تَبَاقُ ؛ عِنْدَ مَعَالِجَتِهَا تَبَاقٌ
44 mature (ripe) fruit capsule	جَرُودُ شَمْرَةٍ نَاضِجَةٍ
45 seed	حَبَّةٌ
46 vanilla plant	فَانِيْلَا ، وَنِيلِيَّةٌ
47 flowering shoot	عَصْبٌ مَزْهَرٌ
48 vanilla pod; when cured: stick of vanilla	قَرْنُ الْفَانِيْلَا ؛ عِنْدَ مَعَالِجَتِهَا عَصَا فَانِيْلَا
49 pistachio tree	شَجَرَةُ فَسْتَقٍ
50 flowering branch with female flowers	فَرْعٌ مَزْهَرٌ ذُو أَزْهَارٍ أُنْثَى

الفروسية، رياضة الفروسية 289
 سباق الدراجات والسيارات 290
 ألعاب الكرة (1) كرة القدم 291
 ألعاب الكرة (2) 292
 ألعاب الكرة (3) 293
 الشيش، المسابقة 294
 التيرينات الحرة 295
 جَمباز الأجهزة (1) 296
 جَمباز الأجهزة (2) (جَمباز السيدات) 297
 ألعاب القوى (مسابقات المضمار والحقل) 298
 رياضات رفع الأثقال والقتال 299
 سَلق الجبال 300
 الرياضات الشتوية (1) التزلج على الجليد 301
 الرياضات الشتوية (2) 302
 الرياضات الشتوية (3) 303
 الريف في الشتاء 304
 رياضات متنوعة 305

تسليّة وثقافة وفن

الكرنفال 306
 السيرك 307
 السوق الموسمية، أرض السوق 308
 سوق السلع الرخيصة أو المستعملة 309
 الأفلام السينمائية (1) 310
 الأفلام السينمائية (2) 311
 الأفلام السينمائية (3) 312
 الأفلام السينمائية (4) 313
 النابله 314
 المسرح (1) 315
 المسرح (2) 316
 صالة الديسكو 317
 الملهى الليلي 318
 مضارعة الثيران 319
 النوتات الموسيقية (1) 320
 النوتات الموسيقية (2) 321
 الآلات الموسيقية (1) 322
 الآلات الموسيقية (2) 323
 الآلات الموسيقية (3) 324
 الآلات الموسيقية (4) 325
 الآلات الموسيقية (5) 326
 المخلوقات الخرافية (المخلوقات الأسطورية) 327
 ما قبل التاريخ 328
 الفروسية 329
 الكنيسة (1) 330
 الكنيسة (2) 331
 الكنيسة (3) 332
 الفن (1) 333
 الفن (2) 334
 الفن (3) 335
 الفن (4) 336
 الفن (5) 337

مرسم، ستوديو الرسام 338
 منحت، ستوديو النحات 339
 فن الجرافيك 340
 أشكال الكتابة (1) 341
 أشكال الكتابة (2) 342
 الألوان 343
 الرياضيات (1) 344
 الرياضيات (2) 345
 الرياضيات (3) (الهندسة) 346
 الرياضيات (4) (الهندسة) 347
 الرياضيات (5) (المجموعات) 348
 معمل الكيمياء (1) 349
 معمل الكيمياء (2) 350
 البلورات وعلم التبلور 351
 علم الأعراق البشرية (1) 352
 علم الأعراق البشرية (2) 353
 علم الأعراق البشرية (3) 354
 اللباس عبر العصور 355

حيوانات ونباتات

حديقة الحيوان 356
 الفقاريات 357
 المفصليات 358
 الطيور (1) 359
 الطيور (2) (الطيور الأروبية) 360
 الطيور (3) (الجوارح) 361
 الطيور (4) (الجوارح) 362
 الطيور (5) (الطيور النادرة) 363
 الأسماك، الزمانيات، والزواحف 364
 قشريات الأجنحة (الفرشاة والبشرات) 365
 الثدييات (1) 366
 الثدييات (2) 367
 الثدييات (3) 368
 أحياء أعماق البحار 369
 علم النبات 370
 أشجار نفضية 371
 الصنوبريات 372
 جَنَبات وأشجار الزينة (1) 373
 جَنَبات وأشجار الزينة (2) 374
 أزهار المرعي والأزهار البرية (1) 375
 أزهار المرعي والأزهار البرية (2) 376
 نباتات الأجرع والمستنقعات والبراحات 377
 النباتات الألبية ونباتات الماء ونباتات المستنقعات 378
 نباتات سامة 379
 نباتات طبية 380
 فطريات صالحة للأكل 381
 نباتات مدارية تستخدم كمنهات وتوابل ومكسبات نكهة 382
 نباتات تستخدم في الصناعة 383
 ثمار جنوبية (مدارية وشبه مدارية وبحر أوسطية) 384

ENGLISH-ARABIC INDEX

مسرّد إنجليزي - عربي

الطواحين 91
تخضير الملت وتصنيع الجعة (1) 91
تصنيع الجعة (2) 93
المحزّر المسلخ 94
أوضاع اللحم 95
محلّ الجزائر/القطّاب (الملمّحة) 96
المخبّز 97
دكّان القفال 98
سوبر ماركت (متجر الخدمة الذاتية) 99
الإسكافي 100
الأخذية 101
أشغال الإبرة 102
الخباط 103
التريزي 104
مصنّف شعر السيدات 105
صالون حلاقة للرجال (الحلاق) 106
التبغ ولوازم التدخين 107
الصانع (صانع الذهب والفضة) 108
الساعاتي 109
الساعات 110
أخصائي البصريات، النظاراتي 111
الألات البصرية (1) 112
الألات البصرية (2) 113
التصوير (1) 114
التصوير (2) 115
التصوير (3) 116
التصوير السينمائي 117
موقع البناء/الإنشاءات (1) 118
موقع البناء/الإنشاءات (2) 119
التجار 120
الأسقف والوصلات الخشبية 121
السقف وأجزاء السقف 122
الأرضية والسقف وإنشاءات السلال 123
الزجاج 124
السباك 125
السباك، عامل تركيب أجهزة الغاز، مهندس السخانات 126
الكهربائي 127
عامل تركيب ورق الحائط 128
الصباغ، النقاش 129
مهندس تصنيع البراميل الخشبية والخزانات 130
الفراء 131
نجار الأثاثات (1) 132
نجار الأثاثات (2) 133
معدّات الإصلاحات المنزلية 134
الخراط 135
السلال (صانع السلال) 136
الحذاء (1) 137
الحذاء (2) (هندسة المربكات الزراعية) 138
تشكيل المعادن بالطرق 139
عامل تشغيل المعادن 140
عامل اللحام بالغاز 141

عامل اللحام القوسي 142
القطع والمسامير وأجزاء الماكينة 143
منتج الفحم 144
الزيت المعدني (النفط، البترول) 145
الحفر البحري 146
مصنّع الحديد والصلب 147
مسيك الحديد و ماكينة الدلفقة 148
آلات الورش (1) 149
آلات الورش (2) 150
مكتب الرسم الهندسي 151
محطة توليد الطاقة (1) 152
محطة توليد الطاقة (2) 153
الطاقة النووية 154
مصادر الطاقة الحديثة 155
وحدة التوكيوك 156
المنشرة 157
المخجر 158
مصنّع الطوب 159
مصنّع الأسمنت 160
صناعة البورسلين والصيني 161
إنتاج الزجاج 162
غزل القطن (1) 163
غزل القطن (2) 164
النسيج (1) 165
النسيج (2) 166
أشغال الإبرة أو التريكو 167
تجهيز ألياف النسيج 168
الألياف الصناعية (1) 169
الألياف الصناعية (2) 170
النسيج وغرز التريكو 171
صناعة الورق (1) 172
صناعة الورق (2) 173
صناعة الطباعة
قسم الجمع الطباعي (1) 174
قسم الجمع الطباعي (2) 175
قسم الجمع الطباعي (الجمع التصويري) (3) 176
الاستيساخ التصويري 177
إعداد الأسطح الطباعة الجلفنة والكليشيهات 178
تخصيص سطح طباعة الأوفست 179
طباعة الأوفست 180
طريقة طباعة الحروف (الطباعة البارزة) 181
الطباعة بالحفر الصوئي 182
تجليد الكتب (1) 183
تجليد الكتب (2) 184
تجليد الكتب (3) 185
النقل والاتصالات وتكنولوجيا المعلومات
عربات تجرّها الجياد 186
الدراجة الهوائية 187
الدراجات النارية، الدراجات الهوائية، الدراجات 188
النارية الخفيفة 188
الدراجة النارية 189

محرّكات الاحتراق الداخلي 190
السيارة (1) 191
السيارة (2) 192
السيارة (3) 193
الشاحنات وعربات النقل الخفيفة والحافلات 194
الكراج (الجراج) 195
محطة خدمة السيارات 196
الترام، قطار كهربائي للخدمة بين الضواحي 197
مقطع عرضي للشارع 198
التخلص من النفايات، تنظيف الشوارع 199
بناء الطرق (1) 200
بناء الطرق (2) 201
خط السكة الحديدية (1) 202
خط السكة الحديدية (2) (معدات الاشارة) 203
صالة المحطة 204
رصيف المحطة 205
محطة الضمانك (متودع الشحن) 206
عربات السكك الحديدية (1) 207
عربات السكك الحديدية (2) 208
عربات السكك الحديدية (3) 209
عربات السكك الحديدية (4) 210
عربات السكك الحديدية (5) 211
عربات السكك الحديدية (6) 212
عربات السكك الحديدية (7) 213
السكك الحديدية الجبلية والسكك الحديدية الكيبالية 214
الجيور 215
الأنهار والهندسة النهريّة 216
القناة الملاحيّة والهندسة الهيدروليّة 217
أنواع القوارب عبر العصور 218
السفن الشراعية (1) 219
السفن الشراعية (2) 220
أنواع السفن 221
بناء السفن 222
السفن البخارية 223
الملاحة 224
أحواض السفن والميناء والمرقا (1) 225
أحواض السفن والميناء والمرقا (2) 226
إنقاذ وقطر السفن 227
إنقاذ الحياة 228
الطائرة (1) 229
الطائرة (2) 230
الطائرة (3) 231
الطائرة (4) 232
المطار 233
الطيران في الفضاء (1) 234
الطيران في الفضاء (2) 235
مكتب البريد (1) 236
مكتب البريد (2) (الإنتمصالات السلكية واللاسلكية) 237
الإذاعة (الراديو والتلفزيون) (1) 238
الإذاعة (الراديو والتلفزيون) (2) 239
الإذاعة (الراديو والتلفزيون) (3) 240
أنظمة الموسيقى (الأنظمة الصوتية) (1) 241
أنظمة الموسيقى (الأنظمة الصوتية) (2) 242

معدّات الفيديو 243
الحاسب الآلي الشخصي 244

المكتب والمصرف ويورصة الأوراق المالية
المكتب (1) 245
المكتب (2) 246
المكتب (3) 247
المكتب (4) 248
المكتب (5) (معدّات مكتبية) 249
البنك/المصرف 250
بورصة الأوراق المالية 251

مجتمع

النقود (العملات المعدنية والأوراق المالية) 252
الأعلام 253
شعارات القبائل والنجبان والتويجات 254
القوات المسلحة (1) (الجيش) 255
القوات المسلحة (2) (القوات الجوية) 256
القوات المسلحة (3) (القوات الجوية) 257
السفن الحربية (1) 258
السفن الحربية (2) (السفن الحربية الحديثة) 259
المدارس (1) (المدارس الابتدائية) 260
المدارس (2) (المدارس الثانوية) 261
الجامعة 262
الانتخابات 263
الشريطة 264
المقهى 265
المطعم 266
الفندق 267
المدينة (وسط المدينة) 268
إمداد المياه 269
الإطفاء (المطافئ) 270
المتجر التنويعي 271
المنزّه 272
ترفيه وألعاب ورياضة
ملعب الأطفال 273
منتجّع المياه المعدنية 274
الروليت 275
ألعاب الرقعات والألعاب الجماعية 276
الطيارانو 277
إقامة المخيمات والكرفانات 278
ركوب الأمواج، الغوص 279
شاطيء الاستحمام 280
حصان السباحة (مركز ترفيهي) 281
السباحة 282
التجديف وسباقات التجديف 283
الإبحار الشراعي (1) 284
الإبحار الشراعي (2) 285
القوارب البخارية، رياضة الانزلاق على سطح الماء 286
الطيران الشراعي 287
الرياضات الجوية 288

المحتويات

الأرقام العربية هي أرقام الصور

الذرة - الكون - الأرض

- الذرة (1) 1
الذرة (2) 2
الفلك (1) 3
الفلك (2) 4
الفلك (3) 5

الهبوط على سطح القمر 6

الغلاف الجوي 7

الأرصاد الجوية (1) 8

الأرصاد الجوية (2) وعلم المناخ 9

أجهزة الأرصاد الجوية 10

الجغرافية الطبيعية (1) 11

الجغرافية الطبيعية (2) 12

الجغرافية الطبيعية (3) 13

الخريطة (1) 14

الخريطة (2) 15

الطبيعة: البيئة والزراعة والحراجه

حديقة الأزهار 51

شُتَان الفواكه والخضروات 52

نباتات داخلية (نباتات المساكن) 53

تكاثر النباتات 54

مزرعة الخضروات 55

أدوات الحديقة 56

الخضروات (نباتات الخضار) 57

الفاكهة الطرية والتفاحيات 58

الجوز واللوزيات 59

أزهار الحدائق 60

نباتات شيطانية، أعشاب ضارة 61

مباني المزرعة 62

الزراعة 63

الآلات الزراعية (1) 64

الآلات الزراعية (2) 65

الأدوات الزراعية 66

الري بالرش 67

المحاصيل الزراعية 68

محاصيل العلف (نباتات الكلاب) 69

فضائل الكلاب 70

الحصان/الفرس (1) 71

الحصان/الفرس (2) 72

الحيوانات الأليفة 73

مزرعة/تربية الدواجن، إنتاج البيض 74

تربية الماشية 75

معمل الألبان 76

النحل و تربية النحل (النخاله) 77

زراعة الكروم 78

قبو الخضار 79

آفات الحدائق والحقول 80

الحشرات المنزلية وآفات الطعام والطفيليات 81

الآفات الحراجية 82

مكافحة الآفات 83

الحراجه (1) 84

الحراجه (2) 85

القنص 86

أسلحة القنص، معدات القنص 87

القنص/الطرائد 88

تربية الأسماك والصيد بالصنارة 89

الصيد في البحار 90

الإنسان وبيئته الاجتماعية

الإنسان (1) 16

الإنسان (2) 17

الإنسان (3) 18

الإنسان (4) 19

الإنسان (5) 20

الإسعافات الأولية 21

الطبيب (1) 22

الطبيب (2) 23

طبيب الأسنان 24

المستشفى (1) 25

المستشفى (2) 26

المستشفى (3) 27

العناية بالطفل ولوازم الأطفال 28

ملابس الأطفال 29

ملابس السيدات (1) (الملابس الشتوية) 30

ملابس السيدات (2) (الملابس الصيفية) 31

الملابس الداخلية، ملابس النوم 32

ملابس الرجال 33

قصات الشعر وأشكال الححية 34

أغذية الرأس 35

المجوهرات 36

أنواع المساكن 37

السطح وخجرة الغلاية 38

المطبخ 39

أدوات وأجهزة المطبخ 40

الصالة 41

غرفة المعيشة 42

غرفة النوم 43

غرفة الطعام 44

مقارن ولوازم المائدة 45

المحتويات

970	المحتويات
673	مسرد إنجليزي - عربي
10	قاموس أوكسفورد - دودن الإنجليزي المصور

دليل استعمال القاموس

القاموس الإنجليزي المصور والمسرد الإنجليزي - العربي والمحتويات الكاملة مرتبة تحت رؤوس الموضوعات التالية:

- الذرة - الكون - الأرض
- الإنسان وبيئته الاجتماعية
- الطبيعة: البيئة والزراعة والحراجة
- مهن وحرف وصناعة
- صناعة الطباعة
- النقل والاتصالات وتكنولوجيا المعلومات
- المكتب والمصرف وبورصة الأوراق المالية
- مجتمع
- ترفيه وألعاب ورياضة
- تسلية وثقافة وفن
- حيوانات ونباتات

للعثور على الترجمة الإنجليزية لإحدى المفردات، عليك أولاً أن تتصفح مجالات الموضوعات المدرجة في "المحتويات" (صفحة 967-970). اختر الموضوع ذا العلاقة، ثم حدد الرقم المتوافق معه في "القاموس الإنجليزي المصور" (الأرقام مثبتة في الركن العلوي من كل صفحة). وإذا ما عثرت على المادة المصورة المطلوبة، ابحث عن الرقم المتوافق معها في "المسرد الإنجليزي - العربي" تحت رأس الموضوع نفسه.

قاموس أوكسفورد - دودن
الإنجليزي المصور
مع مسرد إنجليزي - عربي

المسرد الإنجليزي - العربي من إعداد
مصطفى محمد جبر

قاموس أوكسفورد - دودن الإنجليزي المصور
مع مسرد إنجليزي - عربي